

T9e Treadmills

OPERATION MANUAL



LifeFitness

CORPORATE HEADQUARTERS

10601 West Belmont Avenue
Franklin Park, Illinois 60131 • U.S.A.
847.288.3300 • FAX: 847.288.3703
800.735.3867 (Toll-free within U.S.A., Canada)

INTERNATIONAL OFFICES

LIFE FITNESS ASIA PACIFIC LTD

Room 2610, Miramar Tower
132 Nathan Road
Tsimshatsui, Kowloon
HONG KONG
Telephone: (+852) 2891.6677
FAX: (+852) 2575.6001

LIFE FITNESS ATLANTIC BV

LIFE FITNESS BENELUX

Bijdorpplein 25-31
2992 LB Barendrecht
THE NETHERLANDS
Telephone: (+31) 180.646.666
FAX: (+31) 180.646.699

LIFE FITNESS BENELUX NV

Parc Industriel de Petit-Rechain
4800 Verviers
BELGIUM
Telephone: (+32) 87.300.942
FAX: (+32) 87.300.943

LIFE FITNESS DO BRAZIL

Av. Dr. Dib Sauaia Neto 1478
Alphaville, Barueri, SP
06465-140
BRAZIL
Telephone (+55) 11.4193.8282
FAX: (+55) 11.4193.8283

LIFE FITNESS AUSTRIA

Vertriebs GmbH
Hintschiggasse 1
1100 Vienna
AUSTRIA
Telephone: (+43) 1.61 57 198
FAX: (+43) 1.61 57 198.20

LIFE FITNESS IBERIA

Pol. Ind. Molí dels Frares. c/C, nº 12
08620 Sant Vicenç dels Horts (Barcelona)
Espanña
Telephone: (+34) 93.672.4660
FAX: (+34) 93.672.4670

LIFE FITNESS EUROPE GMBH

Siemensstrasse 3
85716 Unterschleissheim
GERMANY
Telephone: (+49) 89.31 77 51.0
FAX: (+49) 89.31 77 51.99

LIFE FITNESS ITALIA S.R.L.

Via San Pieretto
37010 AFFI (Verona)
ITALY
Telephone: (+39) 045.7238204
FAX: (+39) 045.7238197

LIFE FITNESS LATIN AMERICA and CARIBBEAN

10601 West Belmont Avenue
Franklin Park, Illinois 60131
U.S.A.
Telephone: (+1) 847.288.3300
FAX: (+1) 847.288.3762

LIFE FITNESS UK LTD

Queen Adelaide
Ely, Cambs CB7 4UB
UNITED KINGDOM
Telephone: (+44) 1.353.666 017
FAX: (+44) 1.353.666 018

LIFE FITNESS JAPAN

Nippon Brunswick Bldg., #8F
5-27-7 Sendagaya
Shibuya-Ku, Tokyo
Japan 151-0051
Telephone: (+81) 3.3359.4309
FAX: (+81) 3.3359.4307

Before using this product, it is essential to read this ENTIRE operation manual and ALL installation instructions.

It describes equipment setup and instructs users on how to use it correctly and safely.

Avant d'utiliser ce produit, il est indispensable de lire ce manuel d'utilisation dans son INTÉGRALITÉ, ainsi que TOUTES les instructions d'installations.

Ce manuel explique comment installer l'équipement et comment l'utiliser correctement et sans danger.

Class HB (Home): Domestic use.



CAUTION: Any changes or modifications to this equipment could void the product warranty.

Mise en garde : tout changement ou toute modification de ce matériel peut annuler la garantie du produit.

Any service, other than cleaning or user maintenance, must be performed by an authorized service representative. There are no user serviceable parts.

TABLE OF CONTENTS

Section	Description	Page
1.	Getting Started5
1.1	Important Safety Instructions5
1.2	New Features9
1.3	Setup10
	Electrical Power Requirements // Grounding Instructions //	
	How to Position and Stabilize the Life Fitness Treadmill // Power Switch //	
	Centering the Belt // Fitness Networking // Cable TV Hook-up // Power Cord Routing	
2.	The Display Console14
2.1	Display Console Overview14
2.2	Display Console Descriptions15
2.3	Reading Rack and Accessory Trays23
3.	Heart Rate Zone Training® Exercise24
3.1	Why Heart Rate Zone Training Exercise ?24
3.2	Heart Rate Monitoring25
	The Lifepulse™ System	
	The Optional Heart Rate Chest Strap	
4.	The Workouts26
4.1	Workout Overviews26
4.2	Using the Workouts28
4.3	Workout Descriptions33
	Quick Start // Manual // Random // Fat Burn // Cardio // Hill // Sport Training™ 5K, 10K, (Time) // Heart Rate Hill™ // Heart Rate Interval™ // Extreme Heart Rate™ //	
	Custom workouts // Fit Test // Fit Tests Plus	
4.4	Maximizing Workouts on a Life Fitness Treadmill43
	Selecting a Level // Cool-Down	
5.	User Menu44
5.1	Using the User Menu44
	My Configuration // TV Settings // Custom Workouts	
5.2	My Configuration Settings47
6.	Service and Technical Data48
6.1	Preventive Maintenance Tips48
6.2	Preventive Maintenance Schedule49
6.3	Troubleshooting the Treadmill50
6.4	Troubleshooting the Optional Heart Rate Chest Strap53
6.5	How to Adjust and Tension the Striding Belt54
	The Belt Tensioning Bolts	
	Tracking (Centering) a Striding Belt	
	Tensioning an Existing Striding Belt	
6.6	How to Obtain Product Service56
7.	Specifications57
7.1	Life Fitness T9e Treadmill Specifications57

© 2004 Life Fitness, a division of Brunswick Corporation. All rights reserved. Life Fitness, Lifecycle, FlexDeck, and Zone Training are registered trademarks, and Sport Training, Heart Rate Hill, Heart Rate Interval, Extreme Heart Rate, InstaPace, ZerOut, Lifepulse, MagnaDrive, and Lifespring are trademarks of Brunswick Corporation. Polar is a registered trademark of Polar Electro, Inc. Any use of these trademarks, without the express written consent of Life Fitness or the corresponding companies is forbidden.

This Operation Manual describes the functions of the Life Fitness **T9e** Treadmill:

See "Specifications" in this manual for product specific features.

Statement of Purpose: The treadmill is an exercise machine that enables users to walk or run, in place, on a moving surface.



Health-related injuries may result from incorrect or excessive use of exercise equipment. Life Fitness **STRONGLY** recommends seeing a physician for a complete medical exam before undertaking an exercise program, particularly if the user has a family history of high blood pressure or heart disease, or is over the age of 45, or smokes, has high cholesterol, is obese, or has not exercised regularly in the past year.

If, at any time while exercising, the user experiences faintness, dizziness, pain, or shortness of breath, he or she must stop immediately.



Des problèmes de santé peuvent être causés par une utilisation incorrecte ou excessive de l'équipement. Life Fitness recommande **FORTEMENT** de consulter un médecin pour subir un examen médical complet avant de commencer tout programme d'exercice, et tout particulièrement si l'utilisateur a des antécédents familiaux d'hypertension ou de troubles cardiaques, s'il a plus de 45 ans, s'il fume, s'il a du cholestérol, s'il est obèse ou n'a pas fait d'exercice régulièrement depuis un an.

Si, pendant l'utilisation de l'appareil, l'utilisateur ressent un malaise, des vertiges, des douleurs ou des difficultés à respirer, il doit s'arrêter immédiatement.

1 GETTING STARTED

1.1 IMPORTANT SAFETY INSTRUCTIONS

Read all instructions before using the treadmill.

- **DANGER:** Risk of injury to persons—To avoid injury, stand on the siderails before starting treadmill.
- **DANGER:** To reduce the risk of electrical shock, always unplug this Life Fitness product before cleaning or attempting any maintenance activity.
- **DANGER:** To reduce the risk of burns, fire, electric shock, or injury, it is imperative to connect each product to a properly grounded electrical outlet.
- **WARNING:** Keep the area six feet (two meters) by three feet (one meter) behind the treadmill clear of any obstructions, including walls, furniture, and other equipment.
- **WARNING:** Be sure the emergency stop lanyard is clipped to the user and in proper position on the treadmill before beginning any workout.
- To disconnect, turn power OFF at the ON/OFF switch, then remove plug from electrical outlet.
- Never operate a Life Fitness product if it has a damaged power cord or electrical plug, or if it has been dropped, damaged, or even partially immersed in water. Contact Life Fitness Customer Support Services.
- Keep the power cord away from heated surfaces. Do not pull the equipment by the power cord or use the cord as a handle. Do not run the power cord on the floor under or along the side of the treadmill. Refer to Section 1.2 for proper power cord routing.
- If the electrical supply cord is damaged, it must be replaced by the manufacturer, an authorized service agent, or a similarly qualified person to avoid a hazard.

LOCATION

- Position this product so that the power cord plug is accessible to the user.
- Never operate a Life Fitness product with the air openings blocked. Keep air openings free of lint, hair, or any obstructing material.
- Do not use this product in areas where aerosol spray products are being used or where oxygen is being administered. Such substances create the danger of combustion and explosion.
- Close supervision is necessary when used near children, invalids or disabled persons.
- Do not use this product outdoors, near swimming pools or in areas of high humidity.
- Use this appliance only for its intended use as described in this manual. Do not use attachments that have not been recommended by the manufacturer

OPERATION

- Always follow the console instructions for proper operation.
- Never insert objects into any opening in this product. If an object should drop inside, turn off the power, unplug the power cord from the outlet, and carefully retrieve it. If the item cannot be reached, contact Life Fitness Customer Support Services.
- Do not reach into, or underneath, the unit or tip it on its side during operation.
- Never place liquids of any type directly on the unit, except in an accessory tray or holder. Containers with lids are recommended.
- Do not use this product in bare feet. Always wear shoes. Wear shoes with rubber or high-traction soles. Do not use shoes with heels, leather soles, cleats or spikes. Make sure no stones are embedded in the soles.
- Keep all loose clothing, shoelaces, and towels away from moving parts.
- Handrails may be held to enhance stability as needed, but are not for continuous use.
- Never mount or dismount the treadmill while the running belt is moving. Use the handrails whenever additional stability is required. In case of an emergency, such as tripping, grasp the handrails, and place the feet on the side platforms.
- Never walk or jog backwards on the treadmill.
- When it is necessary to immobilize the treadmill, return to the Welcome Screen. (Pressing the STOP key twice will immediately take the unit to the Welcome Screen.) Hold down the SPEED DOWN key for at least one second, release and press the PAUSE key. (The SPEED DOWN key is the lower arrow on the far right set of arrows on the Control Panel.) The treadmill now displays "IMMOBILIZED." In this state, the treadmill cannot be operated. The main motor and incline are disabled. The treadmill will remain in this state across resets, power cycles, etc. To restore normal operation, repeat the same key sequence: hold down the SPEED DOWN key momentarily, release and press the PAUSE key. The treadmill will return to the Welcome Screen.

**SAVE THESE INSTRUCTIONS
FOR FUTURE REFERENCE.**

1

DÉMARRAGE

1.1 CONSIGNES DE SÉCURITÉ IMPORTANTES

Lire toutes les instructions avant d'utiliser le tapis roulant.

- **DANGER:** Risque de blessures - Afin d'éviter tout risque de blessure, se tenir debout sur les rails latéraux avant de démarrer l'appareil.
- **DANGER:** Pour réduire les risques de décharge électrique, toujours débrancher cet appareil Life Fitness avant le nettoyage ou toute mesure d'entretien.
- **DANGER:** Pour réduire les risques de brûlures, d'incendies, de décharges électriques ou de blessures, chaque appareil doit absolument être branché sur une prise électrique correctement mise à la terre.
- **AVERTISSEMENT:** Conserver une zone de 2 m sur 1 m libre de toute obstruction derrière le tapis roulant (aucun mur, meuble ou autre appareil).
- **AVERTISSEMENT:** S'assurer que la dragonne d'arrêt d'urgence est attachée à l'utilisateur et fixée adéquatement au tapis roulant avant de commencer un exercice.
- Pour débrancher, mettre l'appareil hors tension au niveau de l'interrupteur d'alimentation, puis retirer la fiche de la prise électrique.
- Ne jamais faire fonctionner un produit Life Fitness dont la fiche ou le cordon d'alimentation est endommagé, ni aucun appareil qui serait tombé ou aurait été endommagé ou même partiellement plongé dans l'eau. Appeler le service clientèle de Life Fitness.
- Tenir le cordon d'alimentation à l'écart de toute surface chauffée. Ne pas tirer l'appareil par le cordon d'alimentation; ne pas utiliser le cordon comme poignée. Ne pas faire passer le cordon sur le sol, sous le tapis roulant, ni le long de l'appareil. Se reporter à la section 1.2 pour la disposition adéquate du cordon d'alimentation.
- Si le cordon d'alimentation électrique est endommagé, il doit être remplacé par le fabricant, par un réparateur agréé ou par une personne qualifiée afin d'éviter tout danger.

ENDROIT

- Placer ce produit de manière à ce que l'utilisateur puisse accéder à la fiche du cordon d'alimentation.
- Ne jamais faire fonctionner d'appareil Life Fitness dont les orifices d'aération seraient bloqués. Les garder exempts de peluches, de cheveux ou de toute obstruction.
- Ne pas utiliser ce produit dans des salles où des vaporisateurs aérosols sont employés ou bien où de l'oxygène est administré. Ces substances créent des risques de combustion et d'explosion.
- Une surveillance étroite est nécessaire si l'appareil est utilisé près d'enfants ou de personnes invalides ou handicapées.
- Ne pas utiliser ce produit à l'extérieur, près d'une piscine ou dans des endroits très humides.
- Cet appareil ne doit être employé que pour l'usage auquel il est destiné, conformément aux directives du manuel. Ne pas utiliser d'accessoires qui ne sont pas recommandés par le fabricant.

- Les instructions de la console doivent toujours être suivies pour obtenir un fonctionnement correct.
- Ne jamais rien insérer dans les ouvertures de cet appareil. Si un objet tombe à l'intérieur de l'appareil, couper l'alimentation électrique, débrancher le cordon de la prise et le récupérer avec précaution. S'il est impossible de l'atteindre, communiquer avec le service à la clientèle de Life Fitness.
- Ne pas placer les mains sous l'appareil ou dans l'appareil, et ne pas le renverser sur le côté pendant le fonctionnement.
- Ne pas utiliser cet appareil pieds nus. Toujours porter des chaussures. Porter des chaussures avec des semelles en caoutchouc ou offrant une très bonne adhérence. Ne pas utiliser de chaussures à talons, à semelles en cuir ou munies de crampons. S'assurer qu'aucun caillou n'est incrusté dans les semelles.

FONCTIONNEMENT

- Ne jamais placer aucun liquide directement sur l'appareil, sauf dans le plateau pour accessoires ou un support prévu à cet effet. Il est recommandé d'utiliser des contenants munis de couvercles.
- Éloigner les vêtements lâches, les lacets et les serviettes des pièces en mouvement.
- Les rampes latérales peuvent servir à rétablir son équilibre, mais ne sont pas destinées à un usage continu.
- Ne jamais monter sur le tapis de course et ne jamais en descendre pendant qu'il tourne. Utiliser les rampes latérales afin de ne pas perdre l'équilibre. En cas d'urgence, par exemple, en cas de trébuchement ou de faux pas, saisir les barres latérales et placer les pieds sur les plates-formes latérales.
- Ne jamais marcher ni courir à reculons sur le tapis roulant.
- Quand il est nécessaire d'immobiliser le tapis roulant, retourner à l'écran de bienvenue. (Appuyer deux fois sur la touche STOP ramène immédiatement l'appareil à l'écran de bienvenue.) Tenir brièvement la touche SPEED DOWN (ralentir), la relâcher et appuyer sur la touche PAUSE. (La touche VITESSE VERS LE BAS est la flèche pointant vers le bas à l'extrême droite du groupe de flèches sur le panneau de commande.) L'écran du tapis roulant affiche alors «Immobilisé» Il ne peut alors plus fonctionner, Le moteur principal, la pente et la cireuse sont désactivés. Car le moteur principal et la pente sont désactivés. Le tapis roulant restera immobilisé, même s'il est réinitialisé, mis hors tension, puis remis sous tension, etc. Le mode de fonctionnement normal ne peut être rétabli qu'au moyen de la même séquence de touches : tenir brièvement la touche VITESSE VERS LE BAS enfoncée, la relâcher et appuyer sur la touche PAUSE. Le tapis roulant reviendra à l'écran de bienvenue.

**CONSERVER CES INSTRUCTIONS POUR LE
CONSULTER À L'AVENIR.**

1.2 NEW FEATURES

The Integrated LCD Console on the Life Fitness Treadmill brings together the best LCD technology and the best cardio equipment. It combines eye-catching entertainment with an interactive exercise experience.

NEW FEATURES ON THE LIFE FITNESS TREADMILL INCLUDE:

- **New Touchscreen Display:** This integrated, intuitive touchscreen display features built-in intelligence. This gives exercisers the freedom to watch their favorite TV program and monitor their entire workout progress at the same time, all on one screen.
See Section 2.2 *Display Console Descriptions, Workout Progress*.
- **Ergonomic Viewing:** The ergonomically-positioned viewing angle provides optimal comfort and reduces glare. Plus the protective layer on the Touchscreen Display eliminates direct contact and preserves the life of the LCD screen.
- **Improved Interface:** The sharp screen image, and attractive graphics makes the screen easier to read and to use. There are no complicated steps to setting up a workout—simply choose a workout, enter values and get started.
See Section 4.2 *Using the Workouts*
- **New Help Files:** Now, choosing a workout can be an informed decision. Simply select the question mark on the workout selection screen to access help files, which give explanations of each of the workouts.
See Section 2.2 *Display Console Descriptions, Workout Selection, Help*
- **Workout Flexibility:** Choosing a different workout “on the fly” is as simple as selecting a button, and choosing a new workout. And now there are two ways to change a workout parameter mid-workout—either use the keys on the Control Panel, or use the buttons on the Touchscreen Display.
See Section 4.2 *Using the Workouts, Changing/Ending Workouts, Switching Workouts “On-the-Fly”*
- **Better Monitoring:** The Touchscreen Display shows all relevant workout statistics at one glance.
See Section 2.2 *Display Console Descriptions, Workout Progress*
- **New Time Views:** Lets the user choose the most motivating time display for them. Time can be viewed as Elapsed Time, Remaining Time, or Hidden Time. Changing time views is as simple as touching a button.
See Section 2.2 *Display Console Descriptions, Workout Progress, Elapsed Time*
- **More Options for Managers:** More ways for managers to monitor statistics, track usages, and record personalized messages. Channel setup for the TV allows managers to control which channels are displayed on the TV.
See Section 5 *System Options Menu*

1.3 SETUP

Read the Operation Manual before setting up the Life Fitness Treadmill. Place the treadmill where it will be used before beginning the setup procedure.

ELECTRICAL POWER REQUIREMENTS

The Life Fitness Treadmill requires a non-dedicated line according to the electrical configurations listed in the chart below.

Supply Voltage (VAC)	Frequency (Hz)	Rated Current (Amps)
100	50 / 60	12
120	50 / 60	12
200	50 / 60	6
220	50 / 60	6
230	50 / 60	6
240+	50 / 60	6

NOTE: Do not modify the plug provided with this product. If the plug does not fit into an available electrical outlet, have a proper outlet installed by a qualified electrician.

GROUNDING INSTRUCTIONS

This Life Fitness product must be properly grounded. If the unit malfunctions or breaks down, proper grounding provides a path of least resistance for the electric current, which reduces the risk of shock to anyone touching or using the equipment. Each unit is equipped with an electrical cord, which includes an equipment grounding conductor and a grounding plug. The plug must be inserted into an outlet that has been properly installed and grounded in accordance with all local codes and ordinances.

An adapter MUST NOT BE USED to connect this plug to a two-pole receptacle in North America. If a properly grounded, 15-amp outlet is not available, one must be installed by a qualified electrician.

IL EST ABSOLUMENT INTERDIT d'employer un adaptateur pour brancher cette fiche sur une prise bipolaire en Amérique du Nord. Si aucune prise de 15 A correctement mise à la terre n'est disponible, en faire installer une par un électricien qualifié.

DANGER: A risk of electrical shock may result from improper connection of the equipment-grounding conductor. Check with a qualified electrician if in doubt as to proper grounding technique. **DO NOT** modify the plug provided with the product. If it will not fit an electrical outlet, have a proper outlet installed by a qualified electrician. Any modification to the electrical plug will result in a voided warranty.

DANGER: Un branchement incorrect du conducteur de mise à la terre peut entraîner des risques de décharge électrique. Consulter un électricien si des doutes subsistent quant à la technique de mise à la terre. **NE PAS MODIFIER** la fiche fournie avec l'appareil. Si elle ne s'adapte pas à une prise, faire installer une prise correcte par un électricien qualifié. Toute modification à la fiche annule la garantie.

HOW TO POSITION AND STABILIZE THE LIFE FITNESS TREADMILL

Following all safety instructions in Section 1.1, move the treadmill to the location in which it will be used. See Section 7, titled *Specifications*, for the dimensions of the product footprint (assembled dimensions.) Allow a distance of eight inches, or 21 centimeters, between the treadmill and other units on either side. Allow a distance of six feet, or two meters, from the rear of the treadmill to any object or surface.

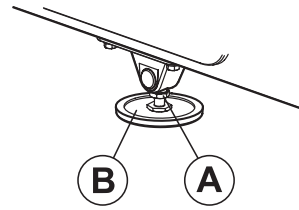

After placing the unit where it will be used, check its stability. If there is even a slight rocking motion or the unit is not stable, determine which stabilizing leg is not resting on the floor. To adjust, loosen the JAM NUT (A), and turn the STABILIZING LEG (B) until the rocking motion ceases, and both stabilizing legs rest firmly on the floor. Retighten the JAM NUT.

NOTE: It is extremely important that the stabilizing leg be correctly adjusted for proper operation. An unbalanced unit may cause striding belt misalignment. A bubble level is recommended to ensure proper leveling.

POWER SWITCH

Located on the front panel at the base of the treadmill, the ON/OFF switch has two positions: "I" (one) for ON and "0" (zero) for OFF.

CENTERING THE BELT

After installing and levelling the treadmill, check the belt to ensure that it is tracking properly. First, plug the power cord into an appropriate outlet. See *Electrical Power Requirements* at the beginning of this section for details. Then, turn the treadmill ON.

Have one person stand on the platforms on either side of the treadmill frame. Do not stand on the belt at this time. Press the QUICK START key, and increase the speed to 4.0 miles per hour (MPH), or 6.4 kilometers per hour (KPH), using the SPEED UP arrow.

If the striding belt moves to the right while it is running, have a second person turn the right tension bolt a quarter-turn clockwise, and then turn the left tension bolt (A) a quarter-turn counter-clockwise. See the illustration below. This action sets the striding belt tracking back to center of the roller.

If the striding belt moves to the left, turn the left tension bolt a quarter-turn clockwise and then turn the right tension bolt a quarter-turn counter-clockwise to start the striding belt tracking back to center of roller.

Repeat these adjustments until striding belt appears centered. Allow the belt to continue running for several minutes to be sure that the tracking is stabilized.

NOTE: Do not exceed one full turn of the adjusting screws in either direction. If, after one full turn, the belt does not track properly, contact Customer Support Services. The phone numbers are listed in Section 6.6, titled *How to Obtain Product Service*.

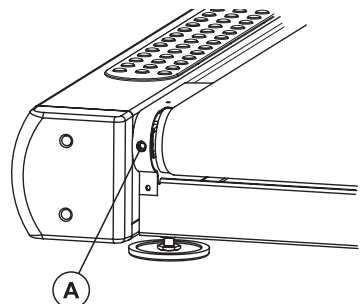

CABLE TV HOOK-UP

Note to the CATV Installer:

This reminder is provided to call the CATV system installer's attention to Article 820-40 of the NEC that provides guidelines for proper grounding and, in particular, specifies that the cable ground shall be connected to the grounding system of the building as close to the point of cable entry as practical.

Antenna Grounding According to the NEC

Antenna Grounding According to the National Electrical Code, ANSI/NFPA 70.

1. Antenna lead in wire
2. Antenna discharge unit (nec section 810-20)
3. Grounding conductors (nec section 810-21)
4. Ground clamp
5. Power service grounding electrode system (nec article 250, part h)
6. Ground clamp
7. Electric service equipment

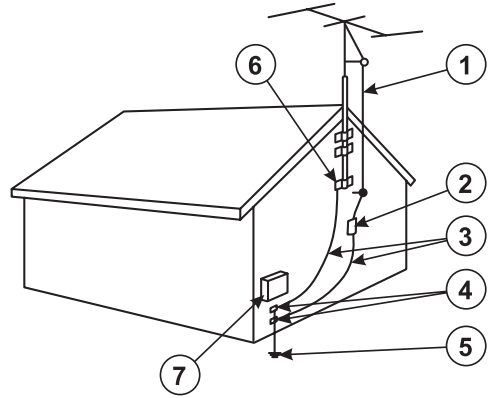

NOTE: *The TV aspect of the LCD Console can only receive a analog signal. Digital cable must be externally converted to an analog signal.*

POWER CORD ROUTING

The power cord can be run straight from the treadmill, shortened and exited out the user-front left side, or run under the frame using the power cord clips and exited out the user right-rear side of the treadmill.

For efficient cord management, the following routing options are recommended:

With the power cord unplugged, insert the clips in the appropriate holes. See the illustration below. Use Hole Pattern 1 or 2 to locate the clips and secure the power cord with the clips, taking up any slack between clips.

NOTE: It may be necessary to tip the treadmill to route the power cord properly.

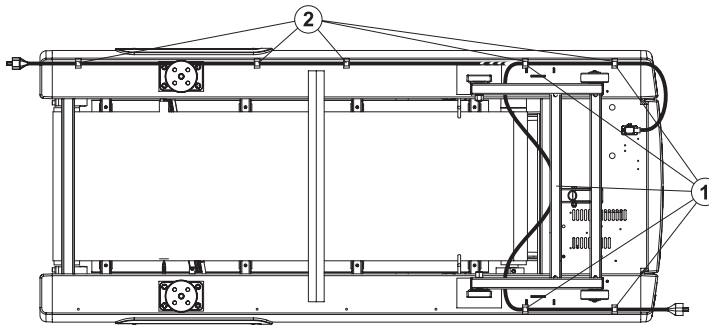

To plug the power cord into an outlet in front of the treadmill, use Hole Pattern 1 for outlets located at the front of the machine.

NOTE: To accommodate treadmill incline, at least two feet (24") of power cord is required between the outlet and the last power cord clip for outlets in front of the treadmill.

To plug the power cord into an outlet in rear of the treadmill, use Hole Pattern 2 for outlets located at the rear of the machine.



WARNING: Make sure that there is a 6-foot clearance behind the treadmill.



DANGER: Insure that the power cord (A) does not contact the striding belt or get pinched between the frame (C), lift arm (B) or the wheel; failure to follow this warning may result in serious injury.

AVERTISSEMENT : S'assurer que le cordon d'alimentation n'entre pas en contact avec le tapis et ne soit pas pincé entre le cadre, le bras de levage ou la roue. Le non-respect de cet avertissement peut provoquer de graves blessures.

NOTE: When using Pattern 1, it is extremely important to route the power cord *BETWEEN* the lift frame and the main frame.

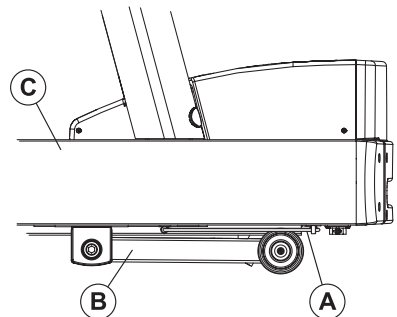

2 THE DISPLAY CONSOLE

2.1 DISPLAY CONSOLE OVERVIEW

The computerized display console on the treadmill allows the user to tailor a workout to personal fitness abilities and goals and to monitor progress. With this easy-to-use console, the user can track fitness improvement from one workout to the next.

The Touchscreen Display: The Touchscreen Display (the LCD screen) allows the user to choose a workout, set it up, and monitor it.

The Control Panel: The Control Panel consists of the keys on the housing of the Touchscreen Display. These keys allow quick changes to workouts “on the fly,” provide easy access to TV controls, and allow for screen cleaning without activating the Touchscreen Display.



ZONE TRAINING			
FAT BURN - LOW INTENSITY		CARDIO - HIGH INTENSITY	
AGE	65%	80%	
10	136	168	
20	130	160	
30	123	152	
40	117	144	
50	110	136	
60	104	128	
70	97	120	
80	91	112	
90	84	104	
100	78	96	
SUGGESTED TARGET HEART RATE AS % OF MAX ACROSS HEART RATE RANGE: 50%-100%			

2.2 DISPLAY CONSOLE DESCRIPTIONS

This section lists and describes the functions for the buttons on the Touchscreen Display and the keys on the Control Panel on the Life Fitness Treadmills. See Section 4, titled *The Workouts*, for detailed information on using the console to set up workouts.

TOUCHSCREEN DISPLAY

The Touchscreen Display allows the user to move from screen by screen by simply touching buttons to access other screens. The Touchscreen Display enables users to access:

- 1) **WORKOUT SELECTION** — choose a workout.
- 2) **WORKOUT SETUP** — enter workout values and goals.
- 3) **WORKOUT PROGRESS** — monitor progress, edit workout goals, and access TV viewing.

1) WORKOUT SELECTION

Touch the Welcome Screen anywhere to start and enter the Workout Selection screen. Use the Workout Selection screen to choose a workout, access QUICK START, or to access the Help screens.

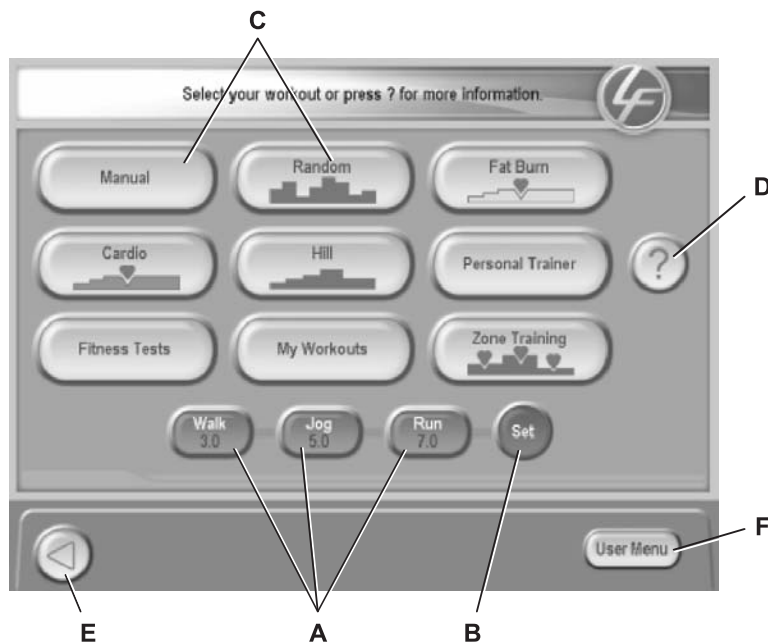

- A. GO SYSTEM QUICK START:** Press any of the Walk, Jog, or Run buttons to begin a manual workout immediately, without having to select a workout program. Once the workout is in progress, use the ARROW keys or the NUMERIC keypad to change the intensity level or workout duration as desired. *ENTER WEIGHT* so that *Calories Burned/Calories per Hour, METs, and Watts* can be computed and displayed. Select the *COOLDOWN* button on the left side of the Control Panel to enter a *Cooldown* phase when ready.

NOTE: The NUMERIC keypad can be accessed by pressing the desired workout attribute button above the ARROW keys.

- B. GO SYSTEM QUICK START SET:** Press the SET button to modify the default values of the Go System WALK, JOG, and RUN speeds. Once selected, choose any of the WALK, JOG, and **RUN BUTTONS** to activate the value. Change the value using the ARROW keys or the NUMERIC keypad. The speed values can be changed in .1 Mph/Kph increments. Press ENTER to accept the changed value. Select the BACK ARROW key to return to the previous screen or workout.
- C. WORKOUT SELECTIONS:** Allows the user to choose from nine different programs. **MANUAL, RANDOM, FAT BURN, CARDIO, AND HILL** lead straight into workout setup screens. **FITNESS TESTS, ZONE TRAINING, PERSONAL TRAINER** and **MY WORKOUTS** give additional workout selections.

Choose **PERSONAL TRAINER** for **SPORT TRAINING (TIME, DISTANCE, CALORIES), SPORT TRAINING (5K), SPORT TRAINING (10K),** and **CUSTOM WORKOUTS** (6 customized workout profiles).

Choose **FITNESS TESTS** for **LIFE FITNESS FIT TEST**. Also available when enabled: **ARMY PFT, GERKIN, NAVY PRT, PHYSICAL EFFICIENCY BATTERY, MARINES PFT,** and **AIR FORCE PRT**. See section 5.1 "My Configuration", *Fit Test Plus* for instructions on how to enable these additional fitness tests.

See Section 4.1 *Workout Overviews* for a description of each workout.

The **MY WORKOUTS** feature on this treadmill makes it possible to pre-set up to seven workouts with personal setup information, such as age or desired speed, and then store the workouts in the console memory. These workouts are accessed with the **MY WORKOUTS** button.

Choose **ZONE TRAINING** for **HR Hill, HR INTERVAL,** and **EXTREME HR**.

Buttons with a heart symbol access workouts that require heart rate monitoring. For more information, see *Workout Profile Window* under *Workout Progress*.

- D. HELP (?):** Select the HELP button to access help buttons for each of the workouts. Use these buttons to get a detailed explanation of each of the workouts.
- E. BACK (◀):** Select BACK to move backward one screen.
- F.> USER MENU:** The User Menu feature can be used to change default settings, enable or disable select programs or displays on the treadmill, configure the TV, and edit Custom Workouts.

2) WORKOUT SETUP

WORKOUT SETUP screens are accessed automatically upon selection of a workout program. They allow the user to enter values or to choose a goal for the workout selected. These depend on the workout, but might include goal type (time, distance and calories), level, age, weight, distance, speed, incline, and target heart rate* (for heart rate programs).

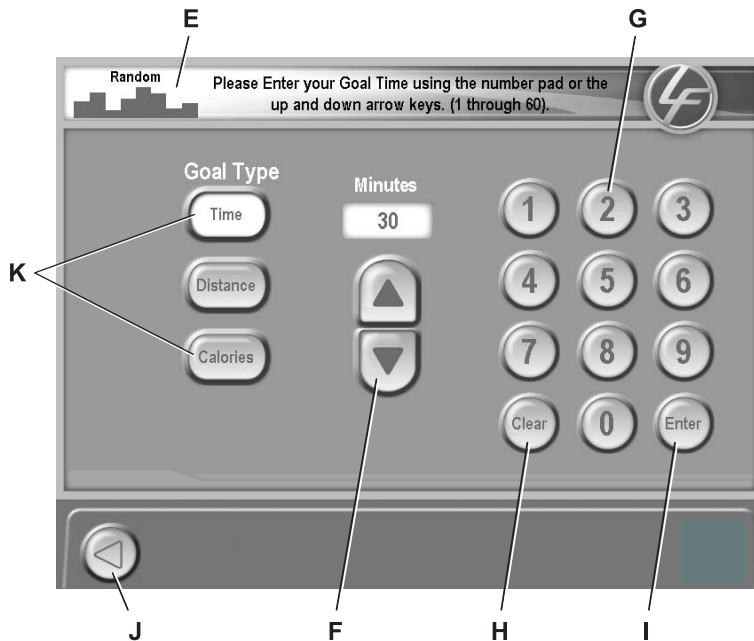

- E. MESSAGE AREA: Shows the user what workout is currently being set up. It also prompts the user for needed information or gives explanations.
- F. ARROW BUTTONS: Use the UP and DOWN arrows to adjust workout values/goals such as length of workout, weight, age, incline, speed, distance, target heart rate, and intensity level. Press ENTER to record the selection.
- G. NUMERICAL KEYPAD: Another way for the user to enter workout parameters. Key in the desired number on the keypad and press ENTER.
- H. CLEAR: Clears any entry and returns the default setting.
- I. ENTER: Press this button after entering a value to register the value and move to the next screen.
- J. BACK: Returns to the previous screen.
- K. GOAL TYPE: Select a desired workout goal type. Choose from TIME, DISTANCE, CALORIES, TIME IN ZONE or MARATHON MODE.

* Target Heart Rate (THR) is a percentage of the theoretical maximum. For example, a 40-year-old user's THR for the **FAT BURN** workout is 117. This workout targets 65 percent of the maximum, so the equation would be $(220-40) \cdot 0.65 = 117$

TYPES OF WORKOUT SETUP SCREENS

GOAL SETUP SCREENS

- **Goal Type:** The default setting of Goal Type is TIME (length of workout.) Allows the user to set a predetermined length of time for the workout.

Users may also choose a more advanced Goal Type such as DISTANCE, CALORIES, MARATHON MODE, or TIME IN ZONE (only available for heart rate programs).

For Distance, Calories, and Time in Zone, the length of the workout depends on how long it takes to reach the goal. The workout continues until the goal is met. To exit early, either choose COOLDOWN from the Bottom Console to go immediately into the Cooldown Phase, or choose CHANGE WORKOUT to access a different program. For more information, see Section 4.2 *Using the Workouts, Selecting a Goal Type*.

Marathon Mode is an un-timed workout. The workout will continue until ended by the user.

For information on how to set, and get maximum benefit from, these type of workout goals consult a Personal Trainer. For further information on Zone Training see section 3.1 of *Heart Rate Zone Training* titled *Why Heart Rate Zone Training Exercise*.

- **Level:** Choose the programmed intensity level of the workout. Levels range from 1 to 20.
- **Incline:** Choose the amount of incline on the treadmill.
- **Speed:** Use to set the striding belt speed of the treadmill.
- **Target Heart Rate*:** (heart rate workouts only) Gives a recommended heart rate according to age. For **Fat Burn**, the target heart rate is computed at 65% of the theoretical maximum[†] heart rate. For **Cardio**, the target heart rate is computed at 80%. For more information on Target Heart Rate, see Section 3, *Heart Rate Zone Training Exercise*.

VALUE SETUP SCREENS

- **Weight:** Entering an accurate weight allows calories to be more accurately calculated, and enables Calories Burned, Calories per Hour, Watts and METs to appear on the Workout Progress screen.
- **Age:** Allows heart programs to accurately determine target heart rate.
- **Gender:** For accurate Fitness Testing.

[†] Defined by the American College of Sports Medicine's "Guidelines for Exercise Testing and Prescription" as equal to 220 minus an individual's age.

* Target Heart Rate (THR) is a percentage of the theoretical maximum. For example, a 40-year-old user's THR for the **FAT BURN** workout is 117. This workout targets 65 percent of the maximum, so the equation would be $(220-40) \times .65 = 117$

3) WORKOUT PROGRESS

The Workout Progress screen opens automatically upon completion of the setup, signaling the user to start the workout. This screen allows the user to monitor the progress of the workout. It provides a visual representation of the workout as it proceeds and monitors distance, pace, elapsed time, heart rate, incline, speed, WATTS/METs, and calories expended/calories per hour.

From the Workout Progress Screen, goals including Time, Incline, Speed and Target Heart Rate* (for heart rate programs) can be changed at any point during the workout. This screen also accesses TV viewing. Not every goal item is available in every workout. Only valid goal values are shown and accessible in the workout progress screen during a workout.

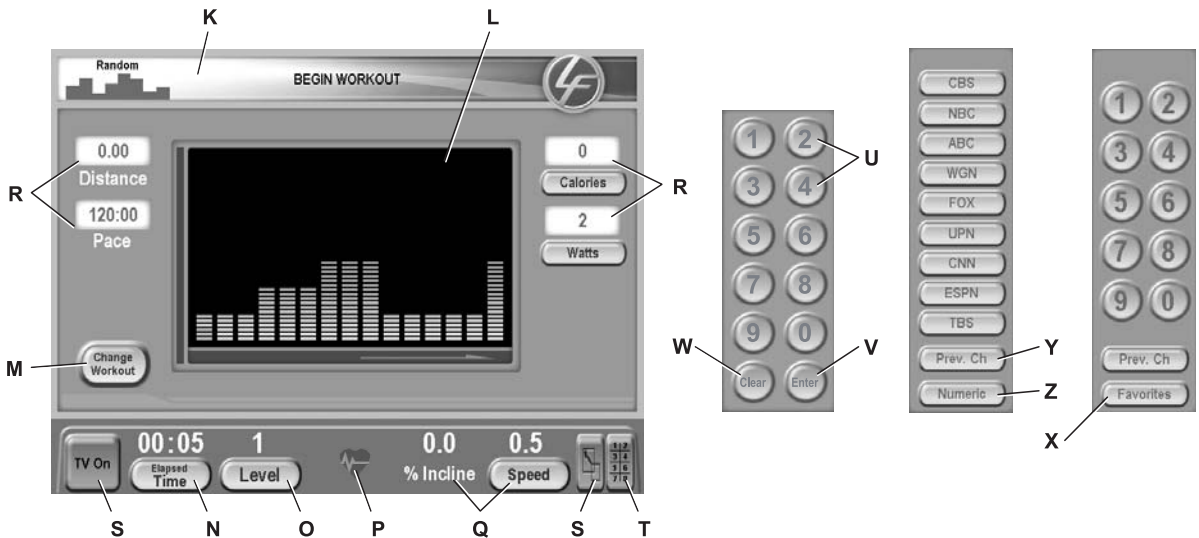

- K.** MESSAGE AREA: Shows the user the workout type, prompts the user for needed information, and explains concepts.
- L.** WORKOUT PROFILE WINDOW: This window displays the levels of intensity in a workout-in-progress as proportional columns. The height of the column furthest to the left is proportional to the current level of intensity.

During a **FAT BURN**, **CARDIO**, **HEART RATE HILL**, **HEART RATE INTERVAL**, or **EXTREME HEART RATE** workout, which requires the use of a Polar heart rate chest strap or the Lifepulse™ system sensors, the WORKOUT PROFILE window displays a flashing heart shape to request the user's heart rate signal. If the console does not detect a signal, the MESSAGE AREA displays the prompt, "NEED HEART RATE-PLACE HANDS ON LIFEPUULSE SENSORS OR USE TELEMETRY STRAP" and the unit beeps 3 times. If the console does not receive the signal within three minutes, the workout automatically is converted to a **MANUAL** program.

- M.** CHANGE WORKOUT: Choose this button to go back to the workout selection screen and choose a new workout, or to change a goal type or value, while retaining workout progress. To change workouts, choose the new program, enter any remaining values, and press ENTER.

* Target Heart Rate (THR) is a percentage of the theoretical maximum. For example, a 40-year-old user's THR for the **FAT BURN** workout is 117. This workout targets 65 percent of the maximum, so the equation would be $(220-40) \cdot 65 = 117$

To adjust a goal type (Calories, Distance, or if in a heart rate program, Time in Zone) or choose a different goal while retaining workout progress, select Change Workout, and then ADJUST GOAL which accesses the goal type screen defaulted to the current goal type and value. To change the goal value, use the ARROW buttons or the NUMERIC keypad, change the value, and then select Enter. To change the goal type, choose a different goal, enter a value, and select ENTER.

To return to the current workout without making any changes, choose BACK. Select the RESET button on the workout selection screen to clear all the stored information about the current workout, before changing to a new program.

- N. **ELAPSED TIME:** Select this button to change the length of the workout or to choose a different view for time. To change workout length, select ELAPSED TIME, use the ARROW buttons or the NUMERIC keypad to adjust the time, and then select ENTER. To change the time view, select ELAPSED TIME, choose a different time view (REMAINING TIME or HIDDEN TIME) and press ENTER.

To change the length of a workout without leaving the workout progress screen, use the ARROW keys on the Control Panel directly underneath ELAPSED TIME.

NOTE: *Changing the length of a workout by using the TIME ELAPSED button has no effect on the time elapsed, which is an ongoing measurement of the time already spent in a workout.*

- O. **LEVEL:** (Hill, Random, Sport Training 5K and 10K) Level refers to a range of incline percentages. The treadmill features 20 levels, with Level 1 having the lowest average incline grade and Level 20 having the highest. See Section 4.4 *Maximizing Workouts on a Life Fitness Treadmill, Selecting a Level* for more information.

TARGET HEART RATE : (replaces level on heart rate workouts only) Displays the target heart rate* the user has specified in the workout setup screens. Can be changed anytime during a workout, by using the ARROW keys directly below it, or by touching the TARGET HEART RATE button on the Touchscreen, and accessing the Target Heart Rate Workout Setup Screen.

- P. **ACTUAL HEART RATE:** Displays the heart rate if the user grasps the Lifepulse sensors or wears a Polar-compatible heart rate chest strap.

NOTE: *Heart rate can be checked on any of the screens, whether before a workout begins, or during a workout.*

- Q. **% INCLINE and SPEED:** Press these buttons to increase or decrease the incline of the treadmill deck, or the striding belt speed. (Use the ARROW keys on the Control Panel directly below % INCLINE AND SPEED to make changes without leaving the Workout Progress Screen.)

- R. **WORKOUT STATISTICS:** Continually updates workout progress by showing Distance, Pace in minutes per mile/kilometer, Calories Expended/Calories per Hour, Target Heart Rate (for heart rate programs), Heart Rate (on any workout if the user is grasping the Lifepulse sensors or wearing a telemetry strap), Time in Zone (if selected as a workout goal) and METs/Watts (toggles between the two if weight has been entered, otherwise only shows Watts).

Cal/Hr and METs/Watts have buttons beneath the displays which give added functionality. These buttons can be used to lock the display or to force the display to toggle. To lock the display, (for instance, turn off the toggle so only calories burned is displayed) simple press the button once while the desired setting is displayed. To toggle (for instance, if METs is displayed to change the display immediately to Watts) press the button twice in succession.

- S. **TV SELECTION:** TV ON/OFF accesses the TV, and enables the Channel and Volume keys on the Control Panel. TV ZOOM (far bottom right) toggles the user between large and small screen TV viewing.

- T. **CHANNEL CONTROLS:** Accesses the channel control keypad on the touchscreen.

- U. **NUMERIC KEYPAD:** Use to enter a new channel selection.

- V. **ENTER:** Select this button to change the channel to the new selection.

* Target Heart Rate (THR) is a percentage of the theoretical maximum. For example, a 40-year-old user's THR for the **FAT BURN** workout is 117. This workout targets 65 percent of the maximum, so the equation would be $(220-40) \cdot 65 = 117$

- W. CLEAR: Clears any entry made, retaining the current channel.
- X. FAVORITE CHANNELS: Use to select a preset favorite channel. See Section 5.1 *System Options Menu, TV Settings* for more information.
- Y. PREVIOUS CHANNEL: Use to enter select the previous favorite channel.
- Z. NUMERIC: Use to toggle to numeric channel selection.

Additional information appearing in the Workout Progress Screen for different workouts:

ENTER WEIGHT: Appears in the Go system Quick Start workouts. Choose ENTER WEIGHT so that METs, Watts, and Calories Burned/Calories per Hour can be computed and displayed as workout statistics.

TIME IN ZONE: Displays the accumulated time that the heart rate stays within the selected target zone for a Heart Rate Zone Training workout. See section 3, titled *Heart Rate Zone Training Exercise*, for more information.

CONTROL PANEL

The Control Panel allows the user to control workout and TV parameters without leaving the

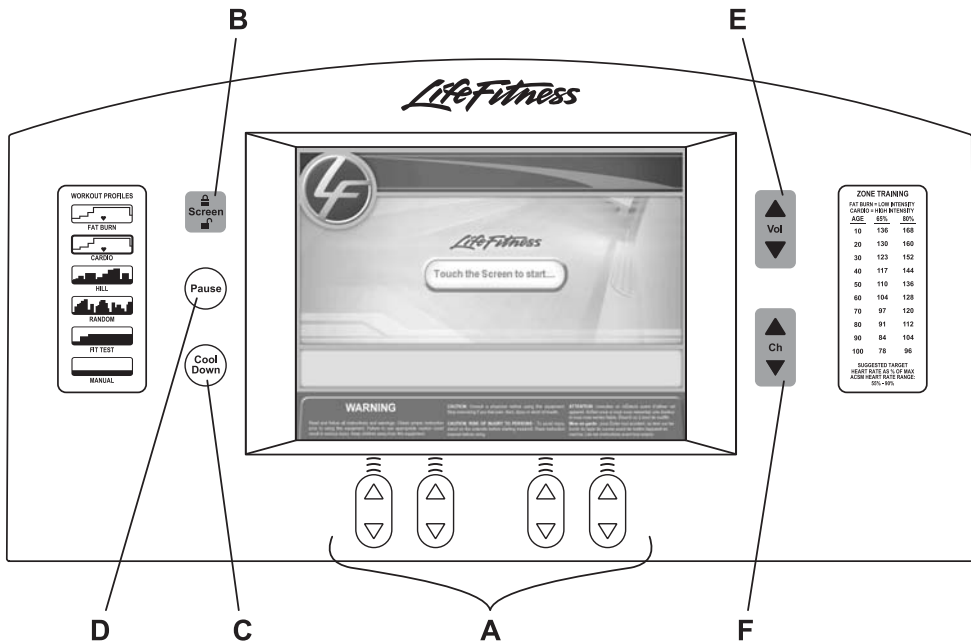

Workout Progress screen. It also provides a quick and easy way for maintenance staff to clean the Touchscreen Display without activating the screen.

- A. **ARROW KEYS:** When in the workout phase, the UP and DOWN ARROW keys are used in combination with the Touchscreen Display. These keys allow the user to make changes to a workout goal during the workout. Each set of ARROW keys controls the goal located directly above it on the Touchscreen Display.

* Target Heart Rate (THR) is a percentage of the theoretical maximum. For example, a 40-year-old user's THR for the **FAT BURN** workout is 117. This workout targets 65 percent of the maximum, so the equation would be $(220-40) \cdot 65=117$

Changeable information (i.e. a workout goal) either appears as a button (Time, Level, Incline, Target Heart Rate*, and Speed) or is accessible through CHANGE WORKOUT, ADJUST GOAL (Calories, Distance, and for heart rate programs, Time in Zone). Workout statistics are not changeable.

For example, use the ARROW keys under ELAPSED TIME (a workout goal) to change the goal time for the session. On the other hand, PACE (a workout statistic) cannot be changed. As described above, workout goals may also be changed by touching the corresponding button on the Touchscreen Display and accessing the corresponding Workout Setup screens.

- B. SCREEN LOCK/UNLOCK:** (Cannot be used during a workout.) Freezes the screen for the purpose of routine maintenance/ screen cleaning. The screen automatically unlocks after ten seconds. Pressing SCREEN LOCK a second time will unlock it as well.
- C. COOLDOWN:** Workout programs end automatically in a Cooldown phase, which lowers the intensity level. In this phase of a workout the body begins to remove lactic acid and other accumulated by-products of exercise, which build up in muscles during a workout and contribute to muscle soreness.

Press the COOLDOWN key to enter the Cooldown stage at any point during the workout. Each workout's Cooldown level is automatically adjusted according to the individual user's performance. (Cooldown times are preset in proportion to the duration of a workout.) The Cooldown time can be changed by using the corresponding ARROW keys on the Control Panel. At the end of Cooldown, a workout summary box appears.

- D. PAUSE:** Press this key to stop the belt and hold the current workout. A RESUME WORKOUT button appears on the Touchscreen. Continue the workout by selecting RESUME WORKOUT or by pressing the PAUSE key a second time.
- E. VOL:** Volume control for the TV.
- F. CH:** Channel control for the TV.

NOTE: Headphones are necessary to access the sound for the TV. The jack is located on the console housing on the lower bottom right. The jack is a user-replaceable feature. Contact Life Fitness Customer Support Services for more information. (See Section 6.6 "How to Obtain Product Service" for contact information.)

A circular-shaped STOP button is located on the right side of the panel below the display console. Press the button to stop the striding belt and end the current workout.



The Life Fitness Treadmill is equipped with a manual emergency stop system. Use the feature described below to stop the treadmill immediately.

A circular-shaped STOP magnet is located on the left side of the panel below the display console. A cord with a clip is attached to this magnet. Before starting a workout, attach the clip to clothing. To stop the striding belt on the treadmill, pull the cord, removing the magnet from the console. Replace the magnet to reset the system.

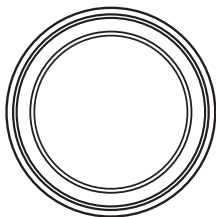

2.3 READING RACK AND ACCESSORY TRAYS

The display console design includes a built-in reading rack (A) allowing a book or magazine to be supported during the workout. Also included in the display console are three built-in accessory trays (B). Two side trays to accommodate large items such as water bottles and one center tray for smaller items such as personal media devices.

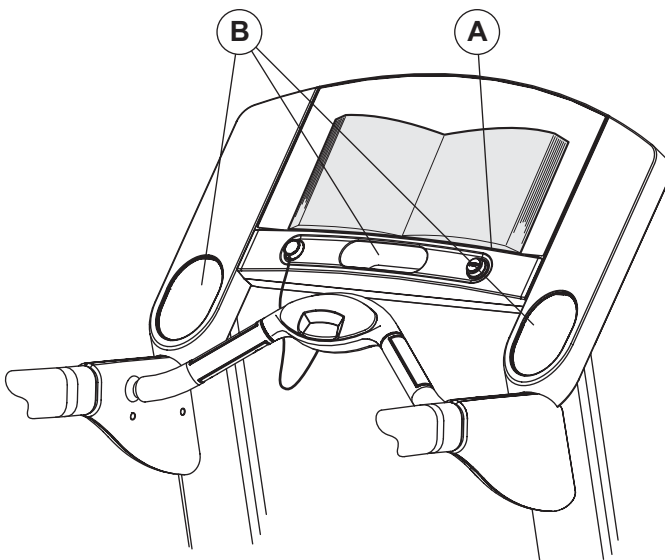

NOTE: Since reading materials will be in front of the Touchscreen Display, use care when placing reading materials on the rack, and when turning pages, to ensure that buttons aren't accidentally toggled.

3

HEART RATE ZONE TRAINING EXERCISE

3.1 WHY HEART RATE ZONE TRAINING EXERCISE?

Research shows that maintaining a specific heart rate while exercising is the optimal way to monitor the intensity of a workout and to achieve maximum results. That is the idea behind the Life Fitness Heart Rate Zone Training approach to exercise.

Zone Training identifies an exerciser's ideal heart rate range, or zone, for burning fat or increasing cardiovascular fitness. The zone is a percentage of the theoretical maximum[†] (HRmax), and its value depends on the workout. The Life Fitness Treadmill features five exclusive workouts designed to take full advantage of the benefits of Heart Rate Zone Training exercise:

- FAT BURN
- HEART RATE HILL
- EXTREME HEART RATE[†]
- CARDIO
- HEART RATE INTERVAL

Each workout offers different benefits, as discussed in Section 4, titled *The Workouts*.

NOTE: Consulting a fitness trainer is recommended for defining specific fitness goals and designing a workout program.

The Heart Rate Zone Training workout programs measure heart rate. Wear the optional telemetry chest strap, or grip the Lifepulse sensors, to enable the treadmill's on-board computer to monitor the heart rate during a workout. The computer automatically adjusts the incline level to maintain the target heart rate* based on the actual heart rate.

To change the target heart rate during a workout, simply enter a new target heart rate either by using the arrows on the Control Panel directly under the target heart rate, or by pressing the Target Heart Rate button on the Touchscreen, and readjusting the setup screen.

To switch between programs during a workout, use the CHANGE WORKOUT button.

ZONE TRAINING		
FAT BURN = LOW INTENSITY CARDIO = HIGH INTENSITY		
AGE	65%	80%
10	136	168
20	130	160
30	123	152
40	117	144
50	110	136
60	104	128
70	97	120
80	91	112
90	84	104
100	78	96

SUGGESTED TARGET HEART RATE AS % OF MAX
ACSM HEART RATE RANGE:
55% - 90%

3.2 HEART RATE MONITORING

THE LIFEPUULSE™ SYSTEM

To use the treadmill's Lifepulse system to check the heart rate during a workout, grasp the stainless steel sensors on the Ergo™ front handlebar. Two sensors are located on each of the handlebars. Contact must be maintained with all four sensors to obtain a heart rate. The console displays a heart rate within 20 to 30 seconds of contact with the sensors.

Do not attempt to grasp the sensors at speeds above walking pace (usually above 4.5 MPH, or 7.2 KPH). For these speeds, the use of a heart rate chest strap is recommended.

THE HEART RATE CHEST STRAP

The Life Fitness Treadmill is equipped with Polar® telemetry, a heart rate monitoring system in which electrodes, pressed against the skin, transfer heart rate signals to the treadmill console. These electrodes are attached to a chest strap that the user wears during the workout.

See the diagram below for correct positioning of the strap. The electrodes (A), which are the two grooved surfaces on the underside of the strap, must remain wet to transmit accurately the electrical impulses of the heart back to the receiver. Moisten the electrodes. Then, secure the strap as high under the chest muscles as possible. The strap should be snug, but comfortable enough to allow for normal breathing.

The transmitter strap delivers its most accurate heart rate reading when the electrodes are in direct contact with bare skin. However, it will function with a slightly less accurate heart rate reading through a thin layer of wet clothing.

If it becomes necessary to re-moisten the chest strap electrodes, grasp the center of the strap, pull it away from the chest to expose the two electrodes, and re-moisten them.

During the setup of a heart rate zone training workout, the user will be required to enter a start-up speed. If a heart rate chest strap is not detected, the maximum allowable speed is 4.5 mph. If a heart rate chest strap is detected, the maximum speed is 12 mph

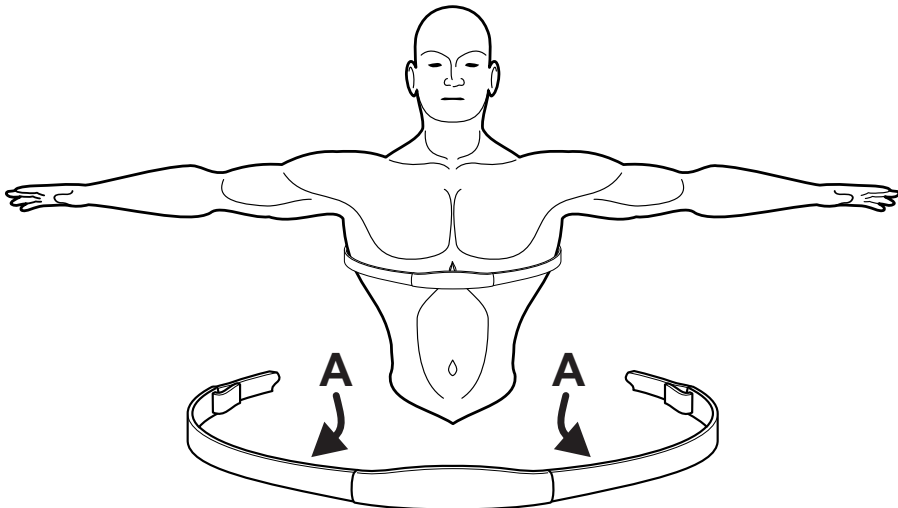

4 THE WORKOUTS

4.1 WORKOUT OVERVIEWS

The following workouts are preprogrammed for the Life Fitness Treadmill.

QUICK START is the fastest way to begin exercising and it bypasses the steps involved in selecting a specific workout program. After the QUICK START key is pressed, a constant level workout begins. The intensity level does not change automatically.

MANUAL is a constant effort workout in which the user can change resistance level or speed at any time.

RANDOM is an interval training workout of constantly changing intensity levels that occur in no regular pattern or progression.

HILL is an interval training workout. Intervals are periods of intense aerobic exercise separated by regular periods of lower-intensity exercise.

FAT BURN is a low-intensity workout for burning the body's fat reserves. The user wears a heart rate chest strap, or grasps the Lifepulse sensors continuously. The program adjusts the intensity level through changing the incline (elevation), based on the actual heart rate, to maintain the rate at 65 percent of the theoretical maximum[†].

CARDIO is a higher intensity workout for more fit users, emphasizing cardiovascular benefits and maximum fat burning. The user wears a heart rate chest strap, or grasps the Lifepulse sensors continuously. The program adjusts the intensity level, based on the actual heart rate, to maintain the rate at 80 percent of the theoretical maximum.

ZONE TRAINING are workouts that target specific ranges, or zones, for maintaining a heart rate to achieve maximum exercise results. Zone Training workouts include:

HEART RATE HILL takes the user through three different hills based on the target heart rate*. The user wears a heart rate chest strap, or grasps the Lifepulse sensors continuously.

HEART RATE INTERVAL alternates between a hill and a valley based on the target heart rate*. The user wears a heart rate chest strap, or grasps the Lifepulse sensors continuously.

EXTREME HEART RATE is an intense workout for more experienced users. It is designed to get the heart rate up and down as quickly as possible. The user wears a heart rate chest strap, or grasps the Lifepulse sensors continuously.

[†] Defined by the American College of Sports Medicine's "Guidelines for Exercise Testing and Prescription" as equal to 220 minus an individual's age.

* Target Heart Rate (THR) is a percentage of the theoretical maximum (HRmax). For example, a 40-year-old user's recommended THR for the FAT BURN workout is 117. The FAT BURN workout targets 65 percent of the maximum, so the equation would be $(220-40) \times .65 = 117$.

FITNESS TESTING workouts measure cardiovascular fitness and can be used to monitor improvements in endurance every four to six weeks.

LIFE FITNESS FIT TEST is a 5 minute workout used to measure cardiovascular fitness compared to other people of the same age and gender.

FIT TEST PLUS (ENABLE/DISABLE) offers additional fitness tests when enabled in My Configuration. See Section 5.1 My Configuration, *Fit Test Plus* for information how to enable these additional tests. These include:

ARMY PHYSICAL FITNESS TEST (PFT) is a 2.0 mile physical performance test used to assess muscular endurance and cardiorespiratory fitness.

GERKIN PROTOCOL is a graded submaximal VO₂ test used by the International Association of Fire Fighters to determine fitness for fire department duty.

NAVY PHYSICAL READINESS TEST (PRT) is the running portion of the Navy PFT. It is a 1.5 mile distance goal test, based on the time needed to complete the required distance, and is used by the U.S. Navy and Naval academies to measure aerobic capacity.

PHYSICAL EFFICIENCY BATTERY (PEB) is used by U.S. Federal Law Enforcement, and the U.S. Federal Bureau of Investigation, and other federal organizations for the hiring and maintenance of federal jobs.

MARINES PHYSICAL FITNESS TEST (PFT) is a 3.0 mile physical performance test used to access muscular endurance and cardiorespiratory fitness.

AIR FORCE PHYSICAL READINESS TEST (PRT) is a 1.5 mile physical performance test used to access muscular endurance and cardiorespiratory fitness.

PERSONAL TRAINER workouts are customized workouts designed either for the advanced user or to be used in connection with a personal trainer. These workouts include:

SPORT TRAINING 5K is a distance-goal workout that simulates an actual terrain with varying incline levels. It is designed to assist runners in training for a 5-kilometer, or 3.1-mile, race.

SPORT TRAINING 10K is a distance-goal workout that simulates an actual terrain with varying incline levels. It is designed to assist runners in training for a 10-kilometer, or 6.2-mile, race.

SPORT TRAINING™ (TIME, DISTANCE, OR CALORIES) is a training workout which can have a Time, Distance, or Calories based goal.

4.2 USING THE WORKOUTS

Select a workout or log on to a fitness network exercise database. See the chart at the beginning of Section 4.3 for an overview of the steps required to set up each workout.

1) BEGINNING A WORKOUT

SELECTING AND USING QUICK START

GO SYSTEM QUICK START is the fastest way to begin exercising. After the WALK, JOG, or RUN button is pressed, a MANUAL workout begins immediately at the pre-programmed speed for the respective button pressed. For accurate caloric expenditure, enter weight using the ENTER WEIGHT button. The incline level is set to zero by default. Change the level using the INCLINE ARROW key. Change the speed using the SPEED key, up or down as desired, or use the NUMERIC keypad to enter a new speed value.

NOTE: The NUMERIC keypad can be accessed by pressing the desired workout attribute button above the ARROW keys.

2) SELECTING A WORKOUT

When prompted to select a workout, select the desired workout button. The touchscreen will then bring up the corresponding Workout Setup Screens which include goal type (time, distance and calories), level, age, weight, distance, speed, incline, and target heart rate*. Press ENTER after each selection to record it. After values are set, the workout progress screen appears and the workout begins.

For **MANUAL**, **FAT BURN**, **HILL**, **RANDOM**, and **CARDIO** choose the corresponding button to enter directly into the workout setup screens.

For **HEART RATE HILL**, **HEART RATE INTERVAL**, and **EXTREME HEART RATE** choose **ZONE TRAINING** and then make a selection.

For **SPORT TRAINING 5K**, **SPORT TRAINING 10K**, **SPORT TRAINING (TIME, DISTANCE, OR CALORIES)** or **CUSTOM WORKOUTS** choose **PERSONAL TRAINER** and then make a selection.

For **LIFE FITNESS FIT TEST** choose **FITNESS TESTING**, and then make a selection. Additional fitness tests are available when **FIT TEST PLUS** is enabled in My Configuration. (See Section 5.1 My Configuration, Fit Test Plus for more information.) These tests include: **ARMY PFT**, **GERKIN**, **NAVY PRT**, **PHYSICAL EFFICIENCY BATTERY**, **MARINES PFT**, and **AIR FORCE PRT**.

3) ENTERING WORKOUT GOALS

SELECTING A GOAL TYPE

Goal Type defaults to TIME (length of workout.) When prompted to enter a Goal Time, use the ARROW KEYS to increase or decrease the displayed time to the desired value, or key in the desired value with the NUMERIC KEYPAD, and press ENTER.

Workouts can be programmed to target advanced goals other than the default time goal:

- DISTANCE
- CALORIES
- TIME IN ZONE (for heart rate workouts only)

* Defined by the American College of Sports Medicine's "Guidelines for Exercise Testing and Prescription" as equal to 220 minus an individual's age.

*Target Heart Rate (THR) is a percentage of the theoretical maximum (HRmax). A 40-year-old user's recommended THR for the CARDIO workout is 144, or 80 percent of the maximum; so the equation would be $(220-40) \cdot 80 = 144$.

The **Distance Goal** feature is designed to build endurance. The user sets a distance goal during the workout setup. Once the goal is met, the workout automatically goes into a Cooldown Phase and ends afterward. To use this feature:

1. Select a workout.
2. In the Goal Type setup screen, choose DISTANCE, enter the desired distance goal, and select ENTER.
3. Finish the setup steps for the selected workout.
4. Begin the workout.

The **Calories Goal** feature is designed to promote weight loss and weight control. The user sets a calorie goal during the workout setup. Once the goal is met, the workout automatically goes into a Cooldown Phase and ends afterward. To use this feature:

1. Select a workout.
2. In the Goal Time setup screen, choose CALORIES, enter the desired calorie goal, and select ENTER.
3. Finish the setup steps for the selected workout.
4. Begin the workout.

The **Time in Zone Goal** program enhances a workout by setting a certain duration within the target heart rate* as a workout goal. The program automatically alters the resistance to maintain a pace that will meet that objective within that duration. Once the objective is met, the workout automatically goes into a Cooldown Phase. To use the Time In Zone Goal feature:

1. Select a workout.
2. In the Goal Time setup screen, choose TIME IN ZONE, enter the desired amount of time, and select ENTER.
3. Finish the setup steps for the selected workout.
4. Begin the workout.

NOTE: *Time in Zone is directly correlated to fitness level. Since the program will continue to increase resistance until the goal is met, it may be wise to start low and work towards a higher goal. Choose COOLDOWN at any time, to exit the workout and immediately enter a Cooldown Phase.*

For help setting TIME IN ZONE goals, consult a personal trainer. For more information on Heart Rate Zone Training, see Section 3.1 *Why Heart Rate Zone Training?*

* Target Heart Rate (THR) is a percentage of the theoretical maximum (HRmax). For example, a 40-year-old user's recommended THR for the FAT BURN workout is 117. The FAT BURN workout targets 65 percent of the maximum, so the equation would be $(220-40) \cdot .65 = 117$.

INTENSITY LEVEL

The Life Fitness Treadmill provides several different ways to adjust the intensity level of an workout. When prompted, use the ARROW keys to increase or decrease the displayed intensity level or target heart rate* to the desired value, or choose the desired value with the NUMERIC KEYPAD, and press ENTER. Adjust the level as needed or desired during the workout.

- Intensity level: The Life Fitness Treadmill provides a selection of 20 intensity levels. Each level represents a range of incline percentages. (See Section 4.4 *Maximizing Workouts on a Life Fitness Treadmill* for a chart showing all 20 levels.) The Workout Profile Window displays the levels of intensity in a workout-in-progress as proportional columns. The height of the column furthest to the left is proportional to the current level of intensity. Selecting a low intensity level at first is recommended. As physical conditioning improves, the levels can increase.
- Target heart rate: Programs that calculate a target heart rate* base this number on the age of the user and the type of workout. The user accepts or adjusts the rate when setting up the workout. During the workout itself, the program reads the heart rate, which is transmitted via the Polar heart rate chest strap or the Lifepulse system sensors; and it uses this data to adjust the resistance. Manually raising the rate increases the intensity of the cardiovascular exercise.

4) ENTERING WORKOUT VALUES

AGE: When prompted to enter Age, use the ARROW KEYS to increase or decrease the displayed age to the correct value, or key in the correct value with the NUMERIC KEYPAD, and press ENTER.

Life Fitness Treadmill workout programs that set a target heart rate* zone first calculate the user's theoretical maximum heart rate¹ by subtracting the user's age from the number 220. The programs then calculate the target zone as a percentage of the theoretical maximum.

WEIGHT: Select weight and press enter. Entering an accurate weight allows for a more accurate calorie calculation and for Watts and METs to be computed and displayed.

GENDER: Select gender and press enter. (Used for the Fitness Testing workouts)

* Target Heart Rate (THR) is a percentage of the theoretical maximum. For example, a 40-year-old user's THR for the **CARDIO** workout is 144. This workout targets 80 percent of the maximum, so the equation would be $(220-40) \cdot .80 = 144$.

5) CHANGING/ENDING A WORKOUT

SWITCHING WORKOUTS “ON-THE-FLY”

It is possible during a workout, to switch to another workout program. After a switch, the console retains all the progress information about the workout since its beginning. To change workouts “on the fly,” simply press CHANGE WORKOUT and then choose a new workout. To switch to a new workout, and restart the progress information, choose CHANGE WORKOUT and then RESET.

CHANGING WORKOUT GOALS DURING A WORKOUT

It is possible during a workout, to change a workout goal (Time, Distance, Calories, and Time in Zone for heart rate programs). To adjust a goal type or choose a different goal, select Change Workout, and then ADJUST GOAL which accesses the goal type screen defaulted to the current goal type and value. To change the goal value, use the ARROW buttons or the NUMERIC keypad, change the value, and then select Enter. To change the goal type, choose a different goal, enter a value, and select ENTER. After the switch, the console retains all the progress information about the workout since its beginning.

PAUSING WORKOUTS

Press this key to stop the belt and hold the current workout. A RESUME WORKOUT button appears on the Touchscreen. Continue the workout by selecting RESUME WORKOUT or by pressing the PAUSE key a second time. The pause duration defaults to 5 minute (configurable by the user), after which, the console returns to the Welcome Screen.

A workout can also be paused by using ZEROOUT speed control. If, during a workout, a user decreases the speed to the minimum and continues to hold the DECREASE SPEED ARROW, the speed falls to 0 (zero) MPH, which is pause mode. The minimum speed is 0.5 MPH, unless changed in My Configuration. See section 5.2, *My Configuration Settings*, for more information.

ENDING WORKOUTS EARLY

To end a workout early, press COOLDOWN on the Control Panel to go directly into the Cooldown phase. The program will designate a Cooldown time period in proportion to the amount of time spent in the workout. Upon completion of Cooldown, a workout summary will appear, which includes the distance travelled, the total calories burned, and other statistics. To exit the program without a Cooldown press the STOP button or select CHANGE PROGRAM, and then RESET.

† Defined by the American College of Sports Medicine's "Guidelines for Exercise Testing and Prescription" as equal to 220 minus an individual's age.

* Target Heart Rate (THR) is a percentage of the theoretical maximum (HRmax). A 40-year-old user's recommended THR for the CARDIO workout is 144, or 80 percent of the maximum; so the equation would be $(220-40)*.80 = 144$.

LIFE FITNESS TREADMILL WORKOUT SETUP STEPS

NOTE: AFTER ENTERING A VALUE (AGE, WEIGHT, HEIGHT, GENDER) OR A GOAL (TIME, LEVEL, INCLINE, SPEED, THR), PRESS ENTER TO REGISTER THE SELECTION.

SELF-CONTAINED WORKOUTS	PERSONAL TRAINER WORKOUTS	FITNESS TESTING WORKOUTS	ZONE TRAINING WORKOUTS
<p>GO SYSTEM QUICK START Press WALK, JOG or RUN Begin workout</p> <p>RANDOM Select RANDOM Enter weight Enter goal type and value Enter level Enter speed Begin workout</p> <p>MANUAL Select MANUAL Enter weight Enter goal type and value Enter incline Enter speed Begin workout</p> <p>FAT BURN** Select FAT BURN Enter weight Enter goal type and value Enter age Accept THR* Enter speed Begin workout</p> <p>HILL Select HILL Enter weight Enter goal type and value Select level Enter speed Begin workout</p> <p>CARDIO** Select CARDIO Enter weight Enter goal type and value Enter age Enter THR* Enter speed Begin workout</p> <p>MY WORKOUTS Press MY WORKOUTS Select Workout Name to begin workout or press Edit and then Workout Name to edit workout Enter to begin workout</p>	<p>CHOOSE PERSONAL TRAINER TO ACCESS:</p> <p>SPORT TRAINING 5K Select SPORT TRAINING 5K Enter weight Enter level Enter speed Begin workout</p> <p>SPORT TRAINING 10K Select SPORT TRAINING 10K Enter weight Enter level Enter speed Begin workout</p> <p>SPORT TRAINING (TIME) Select SPORT TRAINING (TIME) Enter weight Enter time Enter level Enter speed Begin workout</p> <p>CUSTOM WORKOUTS Select CUSTOM WORKOUTS Choose workout Enter weight (If custom workout type is Speed/Incline) Enter Max Speed. Begin Workout (If custom workout type is Target Heart Rate) Enter Age. Enter Speed. Begin Workout</p>	<p>CHOOSE FITNESS TESTING TO ACCESS:</p> <p>LIFE FITNESS FIT TEST** Select LIFE FITNESS FIT TEST Enter weight Enter age Enter gender Enter speed Begin workout</p> <p>FIT TEST PLUS WORKOUTS: (IF ENABLED)</p> <p>PEB Select PEB Enter weight Enter age Enter gender Enter speed Begin workout</p> <p>GERKIN PROTOCOL** Select GERKIN Enter weight Enter age Enter THR* Begin workout</p> <p>NAVY PRT Choose NAVY PRT Choose elevation Enter weight Enter age Enter gender Enter speed Begin workout</p> <p>AIR FORCE PRT Choose AIR FORCE PRT Enter weight Enter age Enter gender Enter speed Begin workout</p> <p>ARMY PFT Select ARMY PFT Enter weight Enter age Enter gender Enter speed Begin workout</p> <p>MARINES PFT Choose MARINES PFT Choose elevation Enter weight Enter age Enter gender Enter speed Begin workout</p>	<p>CHOOSE ZONE TRAINING TO ACCESS:</p> <p>HEART RATE HILL** Select HEART RATE HILL Enter weight Enter goal type and value Enter age Enter THR* Enter speed Begin workout</p> <p>HEART RATE INTERVAL** Select HEART RATE INTERVAL Enter weight Enter goal type and value Enter age Enter THR* Enter speed Begin workout</p> <p>EXTREME HEART RATE** Select EXTREME HEART RATE Enter weight Enter goal type and value Enter age Enter THR* Enter walk speed Enter jog speed Begin workout</p>

* This workout requires the user to wear the polar heart rate chest strap or the grip the Life pulse sensors.

** Target Heart Rate (THR) is a percentage of the theoretical maximum. A 40-year-old user's THR for the **FAT BURN** workout is 117. This workout targets 65 percent of the maximum, so the equation would be $(220-40) \cdot 65 = 117$.

4.3 WORKOUT DESCRIPTIONS

GO SYSTEM QUICK START

GO SYSTEM QUICK START is the fastest way to begin exercising. After the WALK, JOG, or RUN button is pressed, a MANUAL workout begins immediately at the pre-programmed speed for the respective button pressed. For accurate caloric expenditure, enter weight using the ENTER WEIGHT button. The incline level is set to zero by default. Change the level using the INCLINE ARROW key. Change the speed using the SPEED key, up or down as desired. For METs, Watts, Calories Burned/Calories per Hour to be computed and displayed during a workout, select the ENTER WEIGHT button which is required to calculate these values.

	English Default Units	Metric Default Units
WALK	3.0 mph	5,0 kph
JOG	5.0 mph	8,0 kph
RUN	7.0 mph	11,0 kph

To change a preset speed, enter any non-FIT TEST workout. [Press the SET button to modify the default values of the Go System WALK, JOG, and RUN speeds. Once selected, choose any of the WALK, JOG, and RUN BUTTONS to activate the value. Change the value using the ARROW keys or the NUMERIC keypad. The speed values can be changed in .1 Mph/Kph increments. Press ENTER to accept the changed value. Select the BACK ARROW key to return to the previous screen or workout.](#)

NOTE: All changed preset values are preserved when the treadmill is turned off.

NOTE: It is possible to program the WALK, JOG, and RUN speed values per pre-programmed workouts (MY WORKOUTS) - each workout may have a different speed setting for the three Go System Quick Start keys.

The speed is set to the minimum level. To change the speed and stay in the Workout Progress screen, press the UP or DOWN ARROW KEYS on the Control Panel, corresponding to the SPEED button. Speed can also be changed by touching the SPEED button on the Touchscreen Display, which accesses the speed Setup Screen.

The incline level is set to zero by default. To change the incline and stay in the Workout Progress screen, press the UP or DOWN ARROW KEYS on the Control Panel, corresponding to the INCLINE button. Incline can also be changed by touching the INCLINE button on the Touchscreen Display which accesses the incline Setup Screen.

MANUAL

The **MANUAL** program is a constant effort workout in which the user can change resistance level or speed at any time.

RANDOM

The **RANDOM** program creates a terrain of hills and valleys that varies with each workout. More than one million different patterns are possible.

FAT BURN

The **FAT BURN** workout is designed to maintain a user's heart rate at 65 percent of the theoretical maximum[†] (HRmax) for optimal results. Throughout the workout, the user wears a chest strap or grasps the Lifepulse sensors. If the user is not wearing a chest strap, the WORKOUT PROGRESS SCREEN displays a heart shape, and the Message Area prompts the user to grasp the sensors. The console continuously monitors and displays the heart rate, adjusting the intensity level of the treadmill to reach and maintain the target* (See note below). This system eliminates over- and under-training, and it maximizes the aerobic benefits of exercise by using the body's fat stores for fuel.

[†] Defined by the American College of Sports Medicine's "Guidelines for Exercise Testing and Prescription" as equal to 220 minus an individual's age.

* Target Heart Rate (THR) is a percentage of the theoretical maximum (HRmax). A 40-year-old user's recommended THR for the FAT BURN workout is 117, or 65 percent of the maximum, so the equation would be $(220-40) \times .65 = 117$.

CARDIO

The **CARDIO** workout is virtually identical to **FAT BURN**; however the target heart rate** is calculated at 80 percent of the theoretical maximum† (HRmax). The higher target promotes cardiovascular improvement by placing a heavier workload on the heart muscle (See note below).

NOTE: The intensity level is changed by incline. Speed can be only changed by the user. Change the target heart rate at any time by using the **ARROW** keys under the **THR**, or by touching the **THR** button to access the Target Heart Rate Workout Setup Screen.

HILL

The Life Fitness-patented **HILL** workout offers a variety of configurations for interval training. Intervals are periods of intense cardiovascular exercise separated by regular periods of lower-intensity exercise. The **WORKOUT PROFILE WINDOW** represents these high and low intervals as columns of light, which together have the appearance of hills and valleys. The computerized interval training workout has been scientifically demonstrated to promote greater cardiorespiratory improvement than steady-pace training.

The **HILL** workout goes through four phases, each marked by different intensity levels. The **WORKOUT PROFILE** window displays the progress of these phases. As noted in the descriptions below, the heart rate should be measured at two stages in the workout to gauge its effectiveness. Wear the chest strap or continuously grip the Lifepulse™ handles. The Message Area does not display a request for a heart rate measurement, as it does with **CARDIO**, **FAT BURN** and the **HEART RATE ZONE TRAINING** programs.

- 1 **Warm-up** is a phase of low, gradually rising resistance, which brings the heart rate into the lower end of the target zone and increases respiration and blood flow to working muscles.
- 2 **Plateau** increases the intensity slightly, and keeps it steady, to bring the heart rate to the low end of the target zone. Check the heart rate at the end of this phase.
- 3 **Interval Training** is a series of increasingly steeper hills, alternating with valleys, or stints of recovery. The heart rate should rise to the high end of the target zone. Check the heart rate at the end of this phase.
- 4 **Cool-down** is a low-intensity phase that allows the body to begin removing lactic acid, and other exercise by-products, which build up in muscles and contribute to soreness.

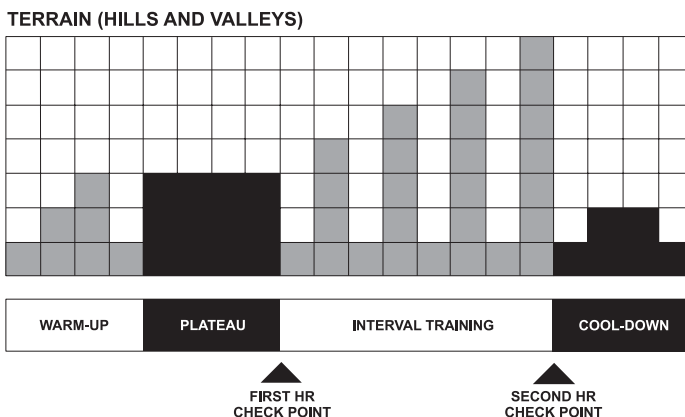

† Defined by the American College of Sports Medicine's "Guidelines for Exercise Testing and Prescription" as equal to 220 minus an individual's age.

** Target Heart Rate (THR) is a percentage of the theoretical maximum (HRmax). A 40-year-old user's recommended THR for the **CARDIO** workout is 144, or 80 percent of the maximum; so the equation would be $(220-40) \cdot 80 = 144$.

Each column, as seen in the **WORKOUT PROFILE WINDOW** and the chart above, represents one interval. The overall duration of the workout determines the length of each interval. Each workout is made up of 20 intervals, so the duration of each interval is equal to the duration of the entire workout divided by 20.

1 to 9 minutes: A workout with a duration of less than 10 minutes is insufficient for the **HILL** program to complete all four phases adequately. The program, therefore, condenses a workout of this duration at various stages.

10 to 19 minutes: The interval durations initially are set at 30 seconds for a 10-minute workout. For every minute over 10, each interval increases by three seconds. A 15-minute workout consists of 20 intervals at 45 seconds each.

20 to 99 minutes: All intervals last 60 seconds. If the user adds minutes to the pre-set duration while the workout is in progress, the program adds hills and valleys that are identical to the first eight intervals of the Interval Training phase. This pattern repeats until the workout is completed.

PERSONAL TRAINER

SPORT TRAINING™

This distance-goal workout is designed for runners training for races. The program creates realistic terrains by setting different incline levels throughout the course. Incline grades depend on the difficulty levels selected during the workout setup. A 1.5 percent incline grade, which is the baseline level, simulates a flat running surface. A zero percent grade simulates running downhill. Incline durations range between 30 and 60 seconds. The course ends when the distance goal is met. Two Sport Training™ programs are available on the treadmill:

- **SPORT TRAINING™ 5K** is a 5-kilometer, or 3.1-mile, course.
- **SPORT TRAINING™ 10K** is a 10-kilometer, or 6.2-mile, course.
- **SPORT TRAINING™ (TIME, DISTANCE, OR CALORIES)** is a time, distance or calories based training workout.

ZONE TRAINING

Zone Training workouts target specific ranges, or zones, for maintaining a heart rate to achieve maximum exercise results.

1) HEART RATE HILL™

This program combines the standard **HILL** workout profile with the concept of Heart Rate Zone Training. The default target heart rate* is calculated as 80 percent of the theoretical maximum† (HRmax), but the user can adjust the target rate during the workout setup. All hills and valleys are percentages of HRmax. The workout consists of three hills that target three heart rate goals: The first hill brings the heart rate to 70 percent of HRmax. The second hill increases the rate to 75 percent of HRmax. The third hill matches the Target Heart Rate bringing the heart rate to 80 percent of HRmax. The valley always is defined as 65 percent of HRmax.

After a standard three-minute warm-up, the workout progresses toward the first hill and heart rate goal. Once the user reaches 70 percent of HRmax, the hill continues for one minute. When the minute expires, the level decreases into a valley. Once the user's heart rate falls to 65 percent of HRmax, the valley continues for one minute. Then, the next hill begins with its corresponding heart rate goal. After the user completes the third hill/valley pair, the program returns to the first hill and repeats the cycle as long as the duration allows. At the end of the duration, the workout goes into a cool-down phase. If the heart rate goes above the theoretical maximum for more than 45 seconds, the treadmill automatically goes into pause mode. If the user does not reach a heart rate goal after five minutes, the Message Area displays a prompt to increase or decrease speed, depending on whether the workout is in a hill or valley phase. The program does not proceed to a new heart rate goal until the user reaches the current goal.

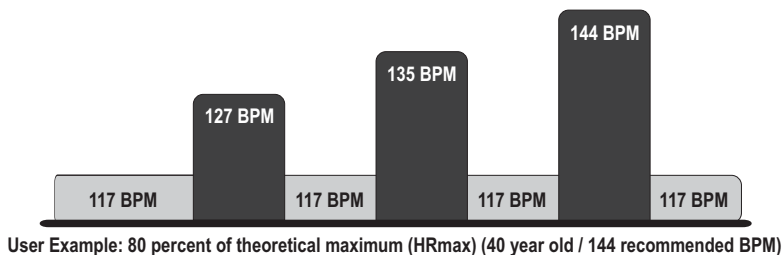
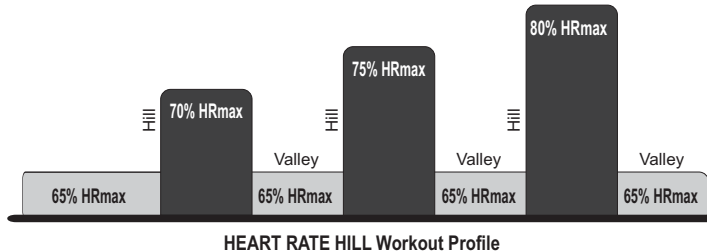

† Defined by the American College of Sports Medicine's "Guidelines for Exercise Testing and Prescription" as equal to 220 minus an individual's age.

* Target Heart Rate (THR) is a percentage of the theoretical maximum (HRmax). A 40-year-old user's recommended THR for the HEART RATE HILL workout is 144, or 80 percent of the maximum; so the equation would be $(220-40) \cdot 80 = 144$.

2) HEART RATE INTERVAL

This program also combines the standard **HILL** workout profile with the concept of Heart Rate Zone Training. The default target heart rate* is calculated as 80 percent of the theoretical maximum† (HRmax), but the user can adjust the target rate during the workout setup. The workout alternates between a hill, which brings the heart rate up to the target rate of 80 percent of HRmax, and a valley, which brings the heart rate down to 65 percent of HRmax. After a standard three-minute warm-up, the workout progresses toward the first hill and heart rate goal. Once the goal is reached, the hill continues for three minutes. Then, the level decreases into a valley. Once the 65 percent of HRmax goal is reached, the valley continues for three minutes, after which the next hill begins. The user's fitness level determines the number of hills and valleys encountered within the duration. At the end of the duration, the workout goes into a cool-down phase. If the heart rate goes above the theoretical maximum† for more than 45 seconds, the treadmill automatically goes into pause mode. If the user does not reach a heart rate goal after five minutes, the Message Area displays a prompt to increase or decrease speed, depending on whether the workout is in a hill or valley phase. The program does not proceed to a new heart rate goal until the user reaches the current goal.

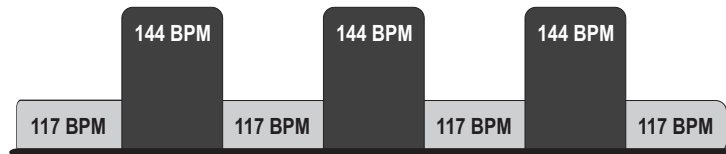
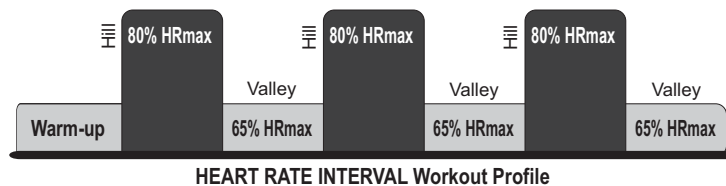

User Example: 80 percent of theoretical maximum (HRmax) (40 year old / 144 recommended BPM)

† Defined by the American College of Sports Medicine's "Guidelines for Exercise Testing and Prescription" as equal to 220 minus an individual's age.

* Target Heart Rate (THR) is a percentage of the theoretical maximum (HRmax). A 40-year-old user's recommended THR for the HEART RATE INTERVAL workout is 144 or 80 percent of the maximum; so the equation would be $(220-40) \cdot 80 = 144$.

3) EXTREME HEART RATE

This intense, varied workout is designed to help more experienced users to break through fitness improvement plateaus. The workout alternates between two target heart rates* as quickly as possible. The effect is similar to that of running sprints. The user must wear a chest strap or grip the Lifepulse™ sensors throughout the workout.

NOTE: It is recommended that users who run at speeds faster than 4.5 MPH wear the chest strap and do not use the Lifepulse™ sensors.

When setting up the workout, the user enters a target heart rate and selects a walk speed and a jog speed. After a standard three-minute warm-up, the treadmill accelerates to the jog speed, and the incline increases, until the user reaches the target heart rate goal of 85 percent of the theoretical maximum† (HRmax). That target rate is maintained for a stabilizing period. Then, the incline is reduced to 0 percent, and the treadmill slows to the walk speed. When the heart rate falls to the 65 percent of HRmax goal, it is maintained there for a stabilizing period. The program repeats the alternating of speeds and incline levels, continuing this pattern throughout the duration.

If the user does not reach a heart rate goal after five minutes, the Message Area displays a prompt to increase or decrease speed, depending on whether the workout is in a hill or valley phase. The program does not proceed to a new heart rate goal until the user reaches the current goal.

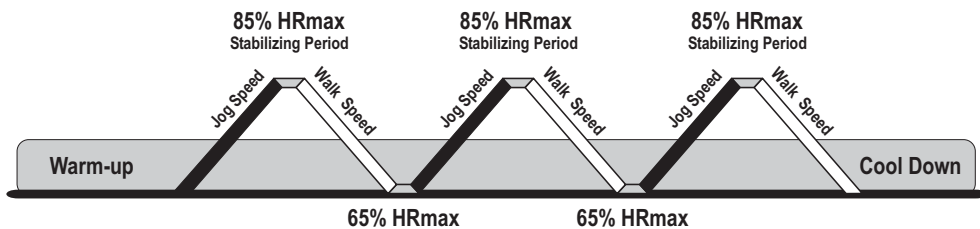

EXTREME HEART RATE Workout Profile

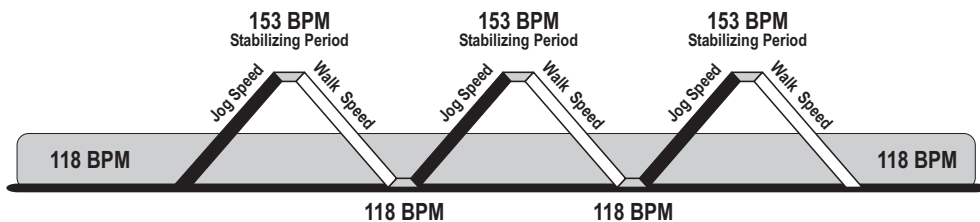

User Example 85 percent of theoretical maximum (HRmax) (40 year old / 153 recommended BPM)

† Defined by the American College of Sports Medicine's "Guidelines for Exercise Testing and Prescription" as equal to 220 minus an individual's age.

* Target Heart Rate (THR) is a percentage of the theoretical maximum (HRmax). For example, a 40-year-old user's recommended THR for the EXTREME HEART RATE™ WORKOUT is 153. The workout program targets a standard 85 percent of the maximum, so the equation would be $(220-40) \cdot 85 = 153$.

FITNESS TESTS

1) LIFE FITNESS FIT TEST

The treadmill Life Fitness Fit Test program is another exclusive feature of this versatile treadmill. The Fit Test workout measures cardiovascular fitness and can be used to monitor improvements in endurance every four to six weeks. The user must grasp the hand sensors (if equipped) when prompted or wear a heart rate chest strap, as the test score calculation is based on a heart rate reading. The workout duration will be five minutes at a 5% incline. Immediately afterward, the console will take the user's heart rate reading, calculate a fitness score, and display the score in the Message Area.

The Fit Test is considered to be a submax VO₂ (volume of oxygen) test. It gauges how well the heart supplies oxygenated blood to the exercising muscles, and how efficiently those muscles receive oxygen from the blood. Physicians and exercise physiologists generally regard this test as a good measure of aerobic capacity.

To set up the Fit Test:

- Choose FITNESS TESTING, LIFE FITNESS FIT TEST.
- Go through the setup screens for the Fit Test, including Weight, and age and gender. Press ENTER after each selection to record the entry. (Gender does not require selecting Enter afterwards.)
- The setup screen for Speed will appear. (ENTER SPEED)(2-4.5 mph). Consult the following recommended fit test level chart for an appropriate effort level based on age, gender and activity level. Press Enter after the selection.

After the five-minute FIT TEST is completed, a FIT TEST score will be displayed.

FIT TEST PROGRAM SUGGESTED EXERTION LEVELS

	Inactive	Active	Very Active
Treadmill Fit Test Level	2-3 mph	3-4 mph	3.5-4.5 mph
	3.2-4.8 kph	4.8-6.4 kph	5.6-7.2 kph

NOTE: Treadmill will incline to 5% after a one minute warm-up.

Suggested exertion levels should be used as a guideline for setting up the Fit Test program. The goal is to elevate the user's heart rate to a level that is between 60%-85% of their theoretical maximum heart rate (220-age).

Within each suggested range, these additional guidelines can be used:

Lower Half of Range	Upper Half of Range
higher age	lower age
lower weight	higher weight*
shorter	taller

* In cases of excessive weight, use lower half of range.

The computer will not accept:

- heart rates less than 52 or greater than 200 beats per minute
- body weights less than 75 pounds (34 kg) or greater than 400 pounds (181 kg)
- ages below 10 or over 99 years
- data input that exceeds human potential

If an error is made when entering any Fit Test data, correct it by pressing CLEAR, inputting the correct information, and pressing ENTER.

It is important to take the Fit Test under similar circumstances each time. Heart rate is dependent on many factors, including:

- amount of sleep the previous night (at least seven hours is recommended)
- time of day
- time of last meal (two to four hours after the last meal is recommended)
- time since last beverage containing caffeine or alcohol, or cigarette (at least four hours is recommended)
- time since last exercised (at least six hours is recommended)

For the most accurate Fit Test results, perform the Fit Test on three consecutive days and average the three scores.

NOTE: *To receive a proper Fit Test score, the work done must be within a training heart rate zone that is 60 percent to 85 percent of the theoretical maximum heart rate (HRmax). This rate is defined by the American College of Sports Medicine's "Guidelines for Exercise Testing and Prescription" as equal to 220 minus an individual's age.*

The tables below list fit test results.

RELATIVE FITNESS CLASSIFICATION FOR MEN

Men	Estimated VO2 Max (ml/kg/min) Per Age Category				
Rating	20-29	30-39	40-49	50-59	60+
Elite	52+	51+	48+	45+	42+
Excellent	50-51	48-50	46-47	42-44	39-41
Very Good	47-49	45-47	43-45	40-41	36-38
Above Average	44-46	42-44	40-42	37-39	33-35
Average	41-43	39-41	37-39	34-36	30-32
Below Average	38-40	36-38	34-36	31-33	27-29
Low	35-37	33-35	31-33	28-30	24-26
Very Low	<35	<33	<31	<28	<24

RELATIVE FITNESS CLASSIFICATION FOR WOMEN

Women	Estimated VO2 Max (ml/kg/min) Per Age Category				
Rating	20-29	30-39	40-49	50-59	60+
Elite	44+	42+	39+	35+	34+
Excellent	42-43	40-41	37-38	33-34	32-33
Very Good	39-41	37-39	35-36	31-32	30-31
Above Average	37-38	35-36	32-34	29-30	28-29
Average	34-36	32-34	30-31	27-28	25-27
Below Average	31-33	29-31	27-29	25-26	23-24
Low	28-30	27-28	25-26	22-24	20-22
Very Low	<28	<27	<25	<22	<20

Life Fitness developed this rating scale based on VO2 max percentile distributions referenced in *American College of Sports Medicine's "Guidelines for Exercise Testing and Prescription"* (6th Ed. 2000). It is designed to provide a qualitative description of a user's VO2 max estimation, and a means of assessing initial fitness level and tracking improvement.

FIT TESTS PLUS (OPTION ENABLE/DISABLE)

When enabled, the Life Fitness Treadmill features additional fitness tests based upon specific predefined protocols. (See section 5.1 “My Configuration”, *Fit Test Plus* for information on how to enable these tests.)

- **ARMY PFT:** 2.0 miles
The U.S. Army Physical Fitness Test is a physical performance test used to assess muscular endurance and cardiorespiratory fitness.
- **GERKIN:** Submaximal VO2
The Gerkin Protocol is a graded submaximal VO2 test used by the International Association of Fire Fighters to determine fitness for fire department duty.
- **NAVY PRT:** 1.5 miles
The running portion of the U.S. Navy Physical Readiness Test is a distance goal test based on the time needed to complete the required distance and is used by the U.S. Navy and Naval academies to measure aerobic capacity.
- **PHYSICAL EFFICIENCY BATTERY:** 1.5 miles
The Physical Efficiency Battery is used by U.S. Federal Law Enforcement, U.S. Federal Bureau of Investigation, and other federal organizations for the hiring and maintenance of federal jobs.
- **MARINES PFT:** 3.0 miles
The U.S. Marines Physical Fitness Test is a physical performance test used to assess muscular endurance and cardiorespiratory fitness.
- **AIR FORCE PRT:** 1.5 miles
The U.S. Air Force Physical Readiness Test is a physical performance test used to assess muscular endurance and cardiorespiratory fitness.

Scores for these tests are based on finishing time, age, and gender.

To set up one of these tests, choose Fitness Test and then choose your selected workout. If the selected test is either the **NAVY** or **MARINES** test, the Message Area displays a question as to whether the test is taking place below a certain altitude. For the **NAVY** test, the altitude is 5,000 feet above sea level; and for the **MARINES** test, the altitude is 4,500 feet above sea level. Using the ARROW KEYS, select the correct answer from: “ABOVE 5,000 FEET”(NAVY) / “ABOVE 4,500 FEET”(MARINES) or “BELOW 5,000 FEET”(NAVY) / “BELOW 4,500 FEET”(MARINES)

Go through the setup screens for the Fit Test, which may include Weight, Age, and Gender. Press ENTER after each entry. Then, begin the workout. To ensure an accurate test score, do not change these entries once the workout begins.

For all FITNESS TESTS except **GERKIN**, after the distance goal is reached, the workout program goes into a cooldown. The duration of this phase depends on the amount of time taken to complete the test. For less than five minutes, the cooldown is one minute. For five to 15 minutes, the cooldown is three minutes. For longer times, the cooldown is five minutes. The user can abort the cooldown by pressing the STOP key. After the cooldown is aborted or completed, the Message Area displays the finishing time and a point score for the PEB, Army, Air Force, and Marines tests; or a qualitative score, such as EXCELLENT, for the Navy test.

For the Gerkin test, the time at which the heart rate reached the target heart rate and is maintained for 15 seconds, and a converted VO2 MAX value will be shown in the MESSAGE AREA during the workout summary.

4.4 MAXIMIZING WORKOUTS ON A LIFE FITNESS TREADMILL

SELECTING A LEVEL

The steps for setting up a **HILL**, **RANDOM**, **SPORT TRAINING 5K**, and **SPORT TRAINING 10K** workout include selecting a level. The word “level” refers to a range of incline percentages. The treadmill features 20 levels, with Level 1 having the lowest average incline grade and Level 20 having the highest.

LEVEL	% Incline	LEVEL	% Incline
1	0.0 - 1.5	11	2.0 - 8.5
2	0.0 - 2.2	12	3.0 - 9.2
3	0.0 - 2.9	13	3.5 - 9.9
4	0.0 - 3.6	14	5.0 - 10.6
5	0.0 - 4.3	15	5.5 - 11.3
6	0.0 - 5.0	16	6.5 - 12.0
7	0.0 - 5.7	17	7.0 - 12.7
8	0.0 - 6.4	18	8.0 - 13.4
9	0.5 - 7.1	19	8.7 - 14.1
10	1.5 - 7.8	20	9.0 - 15.0

Within each level are seven incline percentages, or hills. During a workout, each hill appears in the **WORKOUT PROFILE** window as rows of light stacked in a column. The number of lit rows within a column corresponds to an incline percentage. For example, in Level 5, the lowest incline is 0.0 percent and is represented as one lit row. The highest incline, 4.3 percent, is represented by a column with all seven rows lit.

In the **HILL** and **RANDOM** workouts, these varying hills occur for equal durations, as discussed in the **HILL** workout description. When the workout program brings up a new hill, the incline percentage changes automatically to match that hill.

To change levels during a workout, use the **ARROW** keys or the **NUMERIC** keypad.

COOLDOWN

Life Fitness' unique Cooldown Protocol automatically customizes every cooldown based on each user's workout performance. Workout performance factors, such as speed, incline, duration, and heart rate, determine the duration and intensity of the cool-down.

5 USER MENU

5.1 USING THE USER MENU

The User Menu feature can be used to change default settings, enable or disable select programs or displays on the treadmill, configure the TV, and edit Custom Workouts. To enter the User Menu, press the screen when the "Touch the Screen to start...." Button is visible. Then, touch the "User Menu" button located at the lower right of the screen.

USER MENU OVERVIEW

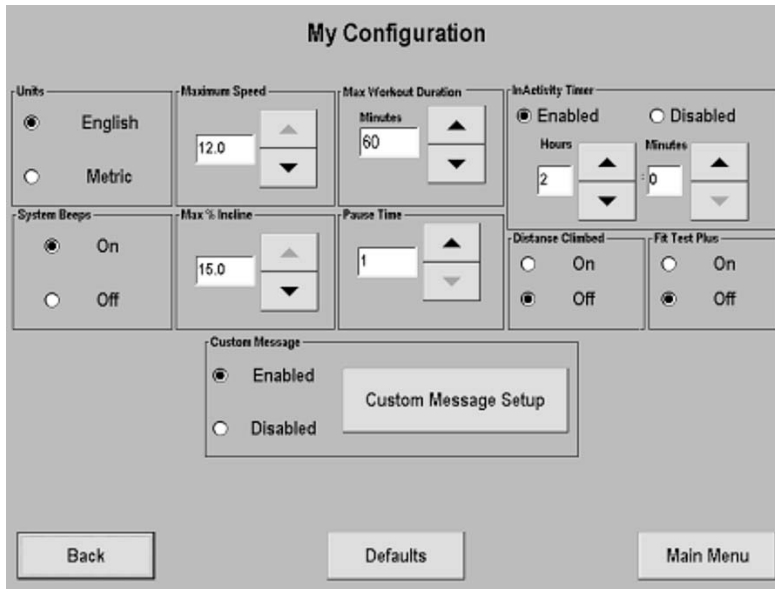

MY CONFIGURATION

Allows the user to set configurable items, program in a custom message.

WORKOUT DURATION CONFIGURATION

Allows the user to set a maximum workout limit. The default configuration has Max Duration set to 99 minutes. The time can be modified using the up or down ARROW keys.

INACTIVITY TIMER

This feature will allow for the backlight to be turned off due to inactivity.

Select ENABLED. Set the desired amount of time of inactivity before the system automatically turns the LCD screen backlight off. The LCD screen will illuminate the next time it is activated (touched). To turn off the Inactivity Timer, choose DISABLED.

CUSTOM MESSAGES

This configuration allows for a custom message to be displayed across the Welcome Screen.

Creating/Changing a Custom Message - Upon entering the Custom Message Setup screen, a message can be entered using the on-screen keyboard. Use the Shift button to input special characters and capital letters. The message will scroll across the top of the screen as the message is being inputted giving real-time feedback.

Accepting a Custom Message - To accept the Custom Message, simply select the Main Menu button.

Erasing a Custom Message - To erase a Custom Message, enter the Custom Message Setup screen. Select the Clear Message button and then select Main Menu.

FIT TEST PLUS

Choose ON to enable the six additional fit tests. If Fit Test Plus is OFF, the only fit test that will appear is the Life Fitness Fit Test.

TO SET DEFAULTS

Select appropriate radio buttons to select toggle settings. Use the ARROW keys to modify variable default values. Select DEFAULTS to return all values to original factory settings. See chart 5.2 for an overview of adjustable configurations and factory defaults of the Life Fitness Treadmill.

TV SETTINGS

Brings up the TV screen and allows adjustment of brightness, contrast, saturation, and hue. Also allows choice of TV format, antenna setup, and channel setup.

To Set Up Channels: Select Channel Setup; Auto; Start.

To Delete an Unwanted Channel: Choose Channel Setup; Manual; use the Channel Controls on the Control Panel to choose the channel to be deleted; select delete; return the Channel Setup to Auto.

To Restore a Channel: Choose Channel Setup; Manual; use the Channel Controls to choose the channel to be restored; select Add; return the Channel Setup to Auto.

To Adjust Picture Setup: Brightness, Contrast, Saturation, and Hue can be adjusted by using the corresponding ARROW buttons. To return to the unit defaults, select DEFAULT.

Max Volume Setup: Opens the Max Volume controls. (Headphones must be used for this function.) The upper set of arrows adjusts the volume capacity higher or lower, allowing the user to compensate for average noise levels within. The maximum volume returns to this default after each workout. The Volume Down, Volume Up arrows control the volume of the unit for the current usage. After each session ends, the unit resets to a mid-range volume corresponding to the maximum volume set up.

Favorite Channel Setup: Opens the Favorite Channel configuration screen. Up to 9 favorite channels can be stored for quick access during a workout. This feature may be enabled or disabled.

To Set Up a Favorite Channel: Select (touch) the radial button next to the input slot desired, touch inside the input box to activate the cursor, select Enter Name, input the channel name using the keyboard display, select OK to accept the channel name, select the desired channel using the Up or Down ARROW Keys. Continue as desired to set up to 9 favorite channels. Select OK to set the channels to memory.

CUSTOM WORKOUTS

Brings up the custom workout configuration screen, which is used to edit any of the 6 custom workouts and to name the custom workout. Select **the** custom workout name to change the name of the custom workout. Select from two types of custom workouts: Speed/Incline or Target Heart Rate. The Speed/Incline **is** selected if you want the speed or incline or both items to change during the custom workout. The Target Heart Rate is selected if you want your Target Heart Rate goal to change during the custom workout. Select the workout time goal (total workout time) for your custom workout. Use the arrow keys at the right-hand side of the screen to change the value of the item (speed, incline, or target heart rate percentage) for the given segment. The number of intervals is always 30, for speed/incline workouts the length of each interval equals the selected duration divided by 30. For target heart rate workouts you can have up to 30 different target heart rate goals. Once you reach the current segment's target heart rate goal the workout will activate the next segment's target heart rate goal.

For speed/incline workouts, each interval is identified by the time at which it occurs during the workout. For target heart rate workouts, each interval is identified by number (1 - 30). If Speed/Incline is selected, two graphs show up (one for speed and one for incline) displaying each interval. For Target Heart Rate workout one graph shows up displaying each interval. To change intervals use the arrow keys under the word Interval.

You can save your custom workout after editing by pressing the OK button. Press the Cancel button if you do not want to save the custom workout. Press the Clear Workout button to erase the custom workout.

5.2 MY CONFIGURATION

MY CONFIGURATION SETTINGS

SETTING	DEFAULT	DESCRIPTION
ENGLISH/METRIC UNITS	ENGLISH	The measurement unit type for weight, distance, and speed.
MAXIMUM SPEED	12.0 (MPH)	This is the fastest speed at which the treadmill can operate.
WORKOUT DURATION	60 (minutes)	This feature enables the user to set a maximum workout duration.
INACTIVITY TIMER CONFIGURATION	OFF	Inactivity Timer: Enables the LCD screen backlight to be turned off due to inactivity. See Section 5.1, <i>Inactivity Timer</i> .
DISTANCE CLIMBED DISPLAY	OFF	The total distance climbed, based on the incline and speed of the treadmill.
FIT TEST PLUS	OFF	Enable/Disable additional Fit Tests: Army PFT; Gerkin protocol; Navy PRT; PEB, Marines PFT; Air Force PRT
PAUSE TIME	5 (minutes)	The maximum amount of time during which a workout can remain in Pause Mode.
MAXIMUM % INCLINE	15.0	This option changes the maximum incline grade to a value lower than 15 percent.
CUSTOM MESSAGE SETUP	ENABLED	See <i>Using the Custom Message Setup</i> in this section.

6 SERVICE AND TECHNICAL DATA

6.1 PREVENTIVE MAINTENANCE TIPS

The Life Fitness Treadmill is backed by the engineering excellence and reliability of Life Fitness and is one of the most rugged and trouble-free pieces of exercise equipment on the market today. Commercial Life Fitness Treadmills are among the most popular of aerobic trainers, regularly standing up to marathon use - 18 hours a day, seven days a week - in health clubs, colleges and military facilities the world over.

NOTE: *Safety of the equipment can be maintained only if the equipment is examined regularly for damage or wear. Keep the equipment out of use until defective parts are repaired or replaced. Pay special attention to parts that are subject to wear, as outlined below.*

REMARQUE : pour conserver un matériel sûr, il convient de l'inspecter régulièrement afin de déceler tout signe d'usure ou d'endommagement. N'utilisez pas l'appareil tant que les pièces défectueuses n'ont pas été réparées ou remplacées. Portez une attention toute particulière aux pièces qui s'usent, comme indiqué ci-dessous.

The following preventive maintenance tips will keep the Life Fitness Treadmill operating at peak performance:

- Clean the display console and all exterior surfaces regularly with mild soap and water or a mild household cleaner. Use only a soft cotton cloth. Apply cleaner to the cotton cloth and before cleaning.
DO NOT use ammonia or acid based cleaners. DO NOT use abrasive cleaners. DO NOT use paper towels, DO NOT apply cleaners directly to equipment surfaces.*
- Check operation of the emergency stop system once a week.
- Check the operation of the stop button and stop magnet once a week.
- Inspect and vacuum the area directly surrounding and under the unit regularly.
- Vacuum around the striding belt regularly to keep debris from accumulating.
- Inspect exterior parts regularly for wear, particularly the striding belt, deck and line cord.
- Check to make sure the unit is properly leveled.
- Check the position (centering) of the striding belt.

The optimum operating position of the striding belt is from 1.5 inches (38 mm) to 2.0 inches (51 mm) from either side of the frame. If the striding belt travels beyond this position, see section 6.5, titled *How to Adjust and Tension the Striding Belt*, or contact Life Fitness Customer Support Services, for proper alignment instructions, 1-800-351-3737 (USA).

***NOTE:** *When cleaning the exterior of the unit, a non-abrasive cleaner and soft cotton cloth are strongly recommended. At no time should cleaner be applied directly to any part of the equipment; use non-abrasive cleaner on a soft cloth and then wipe the unit. Contact Life Fitness Customer Support Services for more details (See Section 6.6 - "How to Obtain Product Service").*

6.2 PREVENTIVE MAINTENANCE SCHEDULE

Follow the schedule below to ensure proper operation of the product.

<i>ITEM</i>	<i>WEEKLY</i>	<i>MONTHLY</i>	<i>QUARTERLY</i>	<i>BI-ANNUAL</i>	<i>ANNUAL</i>
DISPLAY CONSOLE ASSEMBLY					
<i>Hardware</i>			<i>Inspect</i>		
<i>Overlay</i>	<i>Clean</i>			<i>Inspect</i>	
<i>Accessory Cups</i>	<i>Clean</i>				<i>Inspect</i>
<i>Stop Switch</i>	<i>Clean</i>			<i>Inspect</i>	
<i>Emergency Switch/Magnet</i>	<i>Clean</i>			<i>Inspect</i>	
HANDLEBAR ASSEMBLY					
<i>Hardware</i>				<i>Inspect</i>	
<i>Ergo™ Front Handlebar</i>	<i>Clean</i>			<i>Inspect</i>	
<i>Side Hand Rails</i>	<i>Clean</i>			<i>Inspect</i>	
<i>Lifepulse Sensors</i>	<i>Clean/Inspect</i>				
FRAME ASSEMBLY					
<i>Hardware</i>				<i>Inspect</i>	
<i>Motor Cover</i>	<i>Clean</i>				
<i>Motor Electronic Compartment</i>		<i>Vacuum Clean</i>		<i>Inspect</i>	
<i>Drive Belt</i>				<i>Inspect</i>	
<i>Drive Belt Anti-Static Bracket</i>		<i>Inspect</i>			
<i>Anti-Static Cords</i>		<i>Inspect</i>			
<i>Leg Levelers</i>		<i>Inspect/Adjust</i>			
<i>Front Roller</i>				<i>Inspect</i>	
<i>Rear Roller</i>				<i>Inspect</i>	
<i>Side Step Area</i>	<i>Clean</i>		<i>Inspect</i>		
GENERAL					
<i>Machine Level</i>	<i>*Inspect</i>				
<i>Striding Belt Centered</i>	<i>Inspect</i>				
<i>Frame, Toe Guards, Endcaps</i>		<i>Visual Inspect</i>			
<i>Tinsel</i>	<i>Visually Inspect if Treadmill has been Moved Replace Tinsel if Changing Belt and Deck</i>				
<i>*Use bubble level to inspect</i>					

6.3 TROUBLESHOOTING THE TREADMILL

Malfunction	Probable Cause	Corrective Action
No Power	On/Off switch.	Turn the switch to the ON position.
	Insufficient power source.	Plug treadmill into a dedicated 15 amp circuit. Refer to the Operations Manual. Using a voltmeter, verify power at outlet. If no power exists, reset circuit breaker at panel.
	Damaged line cord.	Replace line cord. Contact Life Fitness Customer Support Services*.
	Line cord improperly seated in socket.	Inspect power connection at wall outlet and at machine for proper contact.

* See Section 6.6 "How to Obtain Product Service" for contact information.

TROUBLESHOOTING THE TREADMILL (CONTINUED)

Malfunction	Probable Cause	Corrective Action
Striding Belt slips off-center	Uneven floor surface.	Check levelers and level treadmill. Check striding belt & re-tension as necessary. Refer to Section 6.5 "How to Adjust and Tension the Striding Belt."
Maximum speed is reduced	User is pushing striding belt. This occurs when the runner is running faster than the striding belt will travel, with the result of the striding belt being pushed with the runner's feet.	Instruct users not to push striding belt in either direction.
	User is stalling striding belt. This will occur with heavier users at lower striding belt speeds. The striding belt will "stall" if the user is traveling slower than the striding belt speed.	
	Striding belt/deck malfunction. The deck laminate worn through or the underside of striding belt glazed over (hard, glossy).	Replace belt and deck.
	Insufficient power source.	Plug treadmill into a 15 amp circuit.
Rubbing sound from underneath machine	Foreign objects may be stuck underneath the machine.	Inspect underneath striding belt and machine. Remove any debris or objects that may cause interference with the treadmill.
	Tinsel is installed incorrectly.	Reposition tinsel on the outside of the striding belt.
	Insufficient power source.	Plug treadmill into a 15 amp circuit.
Display does not illuminate when machine is powered on	Loose 10 pin connection at display console or wax/lift control board.	Check all electrical connections for proper attachment. Contact Life Fitness Customer Support Services*.

* See Section 6.6 "How to Obtain Product Service" for contact information.

TROUBLESHOOTING THE TREADMILL (*CONTINUED*)

Malfunction	Probable Cause	Corrective Action
Unit resets randomly or pauses	Insufficient power source.	Plug treadmill into a 15 amp circuit.
	Damaged ground prong on line cord.	Replace line cord.
	Line cord improperly seated in electrical outlet.	Inspect power connection at electrical outlet and at machine (Internation Only) for proper contact.
	Emergency stop magnet not engaged.	Re-engage the emergency stop magnet.
	Stop switch is activated with very light pressure or returns slowly after being pressed.	Contact Life Fitness Customer Support Services*.
	Stop switch cable not making proper contact.	Contact Life Fitness Customer Support Services*.
	Pinched main wire harness.	Contact Life Fitness Customer Support Services*.
	Open ground path.	Contact Life Fitness Customer Support Services*.

* See Section 6.6 "How to Obtain Product Service" for contact information.

6.4 TROUBLESHOOTING THE OPTIONAL HEART RATE CHEST STRAP

HEART RATE READING IS ERRATIC OR ABSENT ENTIRELY

Malfunction	Probable Cause	Corrective Action
Heart rate reading is erratic or absent entirely	Belt transmitter electrodes are not wet enough to pick up accurate heart rate readings.	Wet the belt transmitter electrodes (see section 3.2).
	Belt transmitter electrodes are not laying flat against the skin.	Ensure the belt transmitter electrodes are laying flat against the skin (see section 3.2).
	Belt transmitter needs cleaning.	Wash the belt transmitter with mild soap and water.
	Belt transmitter is not within 3 feet (one meter) of the heart rate receiver.	Make sure the chest strap transmitter is within three feet (one meter) of the heart rate receiver.
	Chest strap battery is depleted.	Contact Life Fitness Customer Support Services* for instructions on how to have the chest strap replaced.
Abnormally elevated heart rate readings	Electromagnetic interference from television sets and/or antennas.	Move the treadmill a few inches away from the probable cause, or move the probable cause a few inches away from the treadmill, until the heart rate readings are accurate.
	Electromagnetic interference from cell phones.	
	Electromagnetic interference from CD players.	
	Electromagnetic interference from computers.	
	Electromagnetic interference from cars.	
	Electromagnetic interference from high voltage power lines.	
	Electromagnetic interference from motor driven exercise equipment.	
	Electromagnetic interference from another heart rate transmitter within three feet (one meter).	

* See Section 6.6 "How to Obtain Product Service" for contact information.

6.5 HOW TO ADJUST AND TENSION THE STRIDING BELT

Do not move treadmill or place hands under treadmill while it is plugged into an electrical outlet!

THE BELT TENSIONING BOLTS

A 5/16-inch hex key wrench is required for this task. The Life Fitness Treadmill has access holes in the rear roller guards which allow access to the tensioning bolts. These tensioning bolts make it possible to adjust the tracking and centering of the striding belt (A) without removing the guards.

NOTE: It is extremely important that the treadmill be correctly leveled prior to any tracking adjustments. An unstable unit may cause striding belt misalignment. See the topic titled "How To Stabilize the Life Fitness Treadmill" in the Section 1.2, titled Set Up, prior to attempting any rear roller adjustments.

Before proceeding, it is helpful to visualize the REAR ROLLER (B) pivot point (C). Each adjustment made to one side of the ROLLER must be met with an equal and opposite adjustment (D) to the other side of the ROLLER to maintain an ideal belt tension at the pivot point.

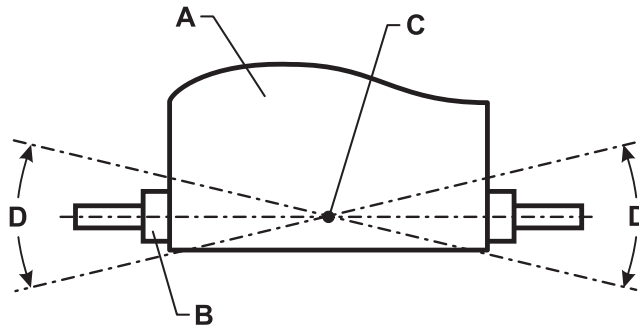

TRACKING (CENTERING) A STRIDING BELT

Two people are needed to perform this procedure.

- 1 Locate the two access holes to the belt tensioning bolts on each of the rear roller guards.
- 2 One person stands on the side rails of the treadmill and straddles the belt. This person presses the MANUAL workout and sets the belt speed to 2.5 MPH (4.0 KPH).
- 3 If the striding belt has moved to the right, the second person turns the right tension bolt a quarter-turn clockwise and then turns the left tension bolt a quarter-turn counter-clockwise to make the striding belt track back to the center of the roller.

If the striding belt has moved to the left, turn the left tension bolt a quarter-turn clockwise and then turn the right tension bolt a quarter-turn counter-clockwise to make the striding belt track back to the center of the roller.

- 4 Repeat the adjustments until the striding belt appears centered. Allow the machine to continue running for several minutes at 4.0 MPH. (6.4 KPH) to observe if tracking remains stabilized.

NOTE: Do not exceed one full turn of the adjusting screws in either direction. If after one full turn the belt does not track properly, contact Customer Support Services. The phone numbers are listed in Section 6.6, titled How to Obtain Product Service.

TENSIONING AN EXISTING STRIDING BELT

- 1 Enter the Manual workout and operate the treadmill for five minutes at 5.0 MPH (8.0 KPH).
NOTE: DO NOT RUN OR WALK ON BELT.
- 2 Reduce the speed to 2.0 MPH (3.2 KPH). Walk on the treadmill. Tightly grip the handrails and apply force with feet on the striding belt near the motor cover against the moving belt direction. If the belt slips, continue to Step 3. If it does not slip, the tension is correct.
- 3 Using the STOP key, stop the treadmill. Turn the belt tensioning bolts a quarter-turn clockwise for each side.
- 4 Repeat STEPS 2 and 3 until the belt no longer slips. Do not exceed one full turn (four quarter turns) per side when adjusting the belt tensioning bolts.
- 5 Enter the MANUAL workout and operate the treadmill at 2.0 MPH (3.2 KPH) check to insure proper tracking (See Section 6.5 *“How to Adjust and Tension the Striding Belt”*). If the striding belt drifts to the left or right see the topic titled *Tracking (Centering) an Existing or New Striding Belt* on the previous page.

Do not over-tighten the tensioning bolts while making belt adjustments. Over-tightening of bolts may over stretch and damage the striding belt or roller bearings. Do not exceed one full turn of either bolt in either direction.

6.6 HOW TO OBTAIN PRODUCT SERVICE

1. Verify the symptom and review the operating instructions. The problem may be unfamiliarity with the product and its features and workouts.
2. Locate and write down the serial number of the unit, which is located on a plate near the power switch.
3. Contact the nearest Life Fitness Customer Support Services group:

For Product Service within
the United States and Canada:

Telephone: (+1) 847.451.0036
FAX: (+1) 847.288.3702
Toll-free telephone: 800.351.3737

For Product Service Internationally:

Life Fitness Europe GmbH
Telephone: (+49) 089.317.751.66
FAX: (+49) 089.317.751.38

Life Fitness (UK) LTD
Telephone: (+44) 1353.665.507
FAX: (+44) 1353.666.719

*Life Fitness Atlantic BV (Europe, Middle
East & Africa except local Life Fitness
offices)*

Life Fitness Benelux
Telephone: (+31) 180.646.666
FAX: (+31) 180.646.699

Life Fitness Italia S.R.L.
Telephone: 800.438.836
FAX: (+39) 0457.238.197

Life Fitness Austria Vertriebs GmbH
Telephone: (+43) 1615.7198
FAX: (+43) 1615.7198.

*Life Fitness Asia Pacific Ltd (Asia &
Australia, except local Life Fitness offices)*
Telephone: (+852) 2891.6677
FAX: (+852) 2575.6001

*Life Fitness Latin America
and Caribbean*
Telephone: (+1) 847.288.3964
FAX: (+1) 847 288.3886

Life Fitness do Brazil
Telephone (+55) 11.4193.8282
FAX: (+55) 11.4193.8283

Life Fitness Japan
Telephone: (+81) 3.3359.4309
FAX: (+81) 3.3359.4307

Life Fitness Iberia (Spain)
Telephone : (+34) 93.672.4660
FAX : (+34) 93.672.4670

7 SPECIFICATIONS

7.1 LIFE FITNESS T9E TREADMILL SPECIFICATIONS

Designed use:	Consumer
Channel coverage:	VHF: 2-13/UHF: 14-69/CATV: 1-125
Antenna:	75-ohm external antenna terminal for VHF/UHF (>43dBuV (@75ohm) or > 65.8dBm)
Headphone Jack:	300 milliwatt, 3.5mm Stereo
Broadcast Capabilities:	NTSC-M or PAL-I, PAL-B/G, SECAM-L
Control Panel:	Arrow keys, screen lock and unlock, cool down, pause and TV controls.
Maximum user weight:	400 pounds / 181 kilograms
Speed range:	0.5 - 12.0 MPH (0.8 - 20 KPH) in 0.1 increments
Elevation range:	0%-15% (in 0.1% increments)
Drive train:	AC motor with MagnaDrive™ motor controller
Motor type:	Variable Speed AC
Motor size:	4.0 HP continuous duty
Power requirements:	120 volt, 15 amp (U.S.). See Electrical Requirements for requirements outside the United States.
Rollers:	5 inch / 13 centimeter diameter, precision-crowned, front and back
Striding Belt:	60" Length x 20" Width (152 cm Length x 51 cm Width), pre-lubricated, multi-ply
Deck type:	3/4" medium density reversible fiberboard
Shock Absorption System:	Patented FlexDeck® Shock Absorption System with Lifeprings™
Ergo™ Front Handrail:	Ergonomically shaped, overmolded elastomeric grips
Side handrails:	26" (66 cm) long, flared, cantilevered, overmolded elastomeric grips
Stop systems:	Red and Yellow magnetic lanyard emergency stop system and Session Stop Push Switch raised and prominently positioned
Workouts:	Go System Quick Start, Fat Burn, Cardio, Hill, Random, Manual, Life Fitness Fit Test, Army PFT, Gerkin, Navy PRT, Physical Efficiency Battery (PEB), Marines PFT, Air Force PRT, Sport Training™ (5K, 10K, and Time), Heart Rate Hill™, Heart Rate Interval™, and Extreme Heart Rate™
Levels:	20 (Hill, Random, Sport Training 5K, 10K, and Time based workouts)
Heart rate monitoring systems:	Patented Lifepulse™ digital contact heart rate and Polar® telemetry compatible heart rate monitoring system
Console displays:	Elapsed time, total distance, total calories burned, Watts, METS, calories burned per hour, speed, incline, heart rate, distance climbed, time in zone, and Profile Window
Ports (1):	Type RJ45
CATV (1):	F-type connector

PHYSICAL DIMENSIONS:

Length:	83 inches / 211 centimeters
Width:	37 inches / 94 centimeters
Height:	65.75 inches / 167 centimeters
Weight:	453 pounds / 204 kilograms
Step-Up Height	13" / 33 centimeters

SHIPPING DIMENSIONS:

Length:	86.25 inches / 219 centimeters
Width:	42.5 inches / 108 centimeters
Height:	28.5 inches / 72 centimeters
Weight:	533 pounds / 240 kilograms



M051-00K60-A062

Life Fitness World Headquarters
10601 W. Belmont Avenue
Franklin Park, IL 60131