

T3₀ / T3₅ TREADMILL

USER MANUAL



LifeFitness

CORPORATE HEADQUARTERS

5100 North River Road
Schiller Park, Illinois 60176 • U.S.A.

www.lifefitness.com

INTERNATIONAL OFFICES

LIFE FITNESS ASIA PACIFIC LTD

Room 2610, Miramar Tower
132 Nathan Road
Tsimshatsui, Kowloon
HONG KONG

LIFE FITNESS ATLANTIC BV

LIFE FITNESS BENELUX

Bijdorplein 25 - 31
2992 LB Barendrecht
THE NETHERLANDS

LIFE FITNESS DO BRAZIL

Av. Dr. Dib Sauaia Neto 1478
Alphaville, Barueri, SP
06465-140
BRAZIL

LIFE FITNESS VERTRIEBS GMBH

Dückergrasse 7-9/3/36
1220 Vienna
AUSTRIA

LIFE FITNESS IBERIA

Pol. Ind. Molí dels Frares. c/C, nº 12
08620 Sant Vicenç dels Horts (Barcelona)
SPAIN

LIFE FITNESS EUROPE GMBH

Siemensstrasse 3
85716 Unterschleissheim
GERMANY

LIFE FITNESS ITALIA S.R.L.

Via Vittorio Veneto, 57/A
39042 Bressanone (Bolzano)
ITALY

LIFE FITNESS LATIN AMERICA and CARIBBEAN

5100 North River Road
Schiller Park, Illinois 60176
U.S.A.

LIFE FITNESS UK LTD

Queen Adelaide
Ely, Cambs CB7 4UB
UNITED KINGDOM

LIFE FITNESS JAPAN

Nippon Brunswick Bldg., #8F
5-27-7 Sendagaya
Shibuya-Ku, Tokyo
JAPAN 151-0051

Before using this product, it is essential to read this ENTIRE operation manual and ALL installation instructions.

This will help in setting up the equipment quickly and in instructing others on how to use it correctly and safely.

FCC Warning - Possible Radio / Television Interference

NOTE: *This equipment has been tested and found to comply with the limits for a Class B digital device, pursuant to part 15 of the FCC rules. These limits are designed to provide reasonable protection against harmful interference in a residential installation. This equipment generates, uses and can radiate radio frequency energy, and if not installed and used in accordance with the operation manual, may cause harmful interference to radio communications. However, there is no guarantee that the interference will not occur in a particular installation. If this equipment does cause harmful interference to radio or television reception, which can be determined by turning the equipment off and on, the user is encouraged to try to correct the interference by one or more of the following measures:*

Reorient or relocate the receiving antenna.

Increase the separation between the equipment and the receiver.

Connect the equipment into an outlet on a circuit different from that to which the receiver is connected.

Consult the dealer or an experienced radio/TV technician for help.

Class HB (Home): Domestic use. Not suitable for therapeutic purposes.



CAUTION: Any changes or modifications to this equipment could void the product warranty.

Any service, other than cleaning or user maintenance, must be performed by an authorized service representative. There are no user-serviceable parts.

TABLE OF CONTENTS

1.	Getting Started	.6
1.1	Important Safety Instructions	.6
1.2	Setup	.8
	Electrical Power Requirements // Grounding Instructions // How to Stabilize the Life Fitness Treadmill // Power Switch // Immobilizing the Treadmill // Centering the Belt	
2.	The Display Console	.12
2.1	Display Console Overview	.12
2.2	Display Console Descriptions	.13
2.3	Reading Rack	.15
2.4	Accessory Trays	.15
3.	HeartSync™ Exercise	.16
3.1	Why HeartSync™ Exercise?	.16
3.2	Heart Rate Monitoring	.17
	The Polar® Heart Rate Chest Strap	
4.	The Workouts	.18
4.1	Workout Overviews	.18
4.2	Setting Up Workouts	.20
4.3	Workout Descriptions	.22
	Go System-Quick Start™ // Hill // Random // Manual // EZ Incline™ // Sport Training™ // 5K Sport Training™ // 10K Sport Training™ // HeartSync Workouts // Fat Burn // Cardio // Heart Rate Hill™ // Heart Rate Interval™ // Extreme Heart Rate™ // 30-Minute Walk // 3-Mile Jog // 45-Minute Cross-Train // Cool-down	

4.4	My Workout	.34
	Using a Workout Saved Under My Workout // Editing Settings for Workouts Saved Under My Workout	
4.5	Custom Workout	.36
	Using a Custom Workout // Editing Custom Workout Settings	
4.6	Selecting an Intensity Level	.38
5.	User Menu	.40
5.1	Entering and Using the User Menu	.40
5.2	User Menu Items	.41
	User Statistics // Settings // Software Version Numbers	
6.	Service and Technical Data	.44
6.1	Preventive Maintenance Tips	.44
6.2	Troubleshooting the Heart Rate Chest Strap	.45
	Heart Rate Reading Is Erratic or Absent Entirely // Heart Rate Reading Is Erratic or Extremely High	
6.3	How to Adjust and Tension the Striding Belt	.46
	The Belt Tensioning Bolts // Tracking (Centering) an Existing or New Striding Belt // Tensioning an Existing Striding Belt	
6.4	How to Obtain Product Service	.48
7.	Specifications	.49
7.1	Life Fitness T30 Treadmill Specifications	.49
7.2	Life Fitness T35 Treadmill Specifications	.51
8.	Warranty Information	.53

© 2005 Life Fitness, a division of Brunswick Corporation. All rights reserved. Life Fitness and FlexDeck are registered trademarks and Lifespring, Go System-Quick Start, HeartSync, Heart Rate Hill, Heart Rate Interval, Extreme HR, EZ Incline, and 5K (and 10K) Sport Training are trademarks of Brunswick Corporation. Polar is a registered trademark of Polar Electro, Inc. Any use of these trademarks, without the express written consent of Life Fitness or the corresponding companies is forbidden.

This Operation Manual describes the functions of the following products:

Life Fitness Treadmill Models:

T3₀ & T3₅

See "Specifications" in this manual for product specific features.

Statement of Purpose: The Treadmill is an exercise machine that enables users to walk or run in place on a moving surface.



Health-related injuries may result from incorrect or excessive use of exercise equipment. The manufacturer **STRONGLY** recommends seeing a physician for a complete medical exam before undertaking an exercise program, particularly if the user has a family history of high blood pressure or heart disease; or is over the age of 45; or smokes, has high cholesterol, is obese, or has not exercised regularly in the past year. The manufacturer also recommends consulting a fitness professional on the correct use of this product.

If, at any time while exercising, the user experiences faintness, dizziness, pain, or shortness of breath, he or she must stop immediately.

1 GETTING STARTED

1.1 IMPORTANT SAFETY INSTRUCTIONS

Read all instructions before using the treadmill.

DANGER: To reduce the risk of electrical shock, always unplug this Life Fitness product before cleaning or attempting any maintenance activity.

WARNING: To reduce the risk of burns, fire, electric shock or injury, it is imperative to connect each product to a properly grounded electrical outlet.

- To disconnect, turn power OFF at the ON/OFF switch, then remove plug from electrical outlet.
- Never operate a Life Fitness product if it has a damaged power cord or electrical plug; or if it has been dropped, damaged, or even partially immersed in water. Contact Life Fitness Customer Support Services.
- Position this product so the power cord plug is accessible to the user.
- Keep the power cord away from heated surfaces. Do not pull the equipment by the power cord or use the cord as a handle. Do not run the power cord on the floor, under or along the side of the treadmill.
- If the electrical supply cord is damaged it must be replaced by the manufacturer, an authorized service agent, or a similarly qualified person to avoid a hazard.
- Do not use this product in areas where aerosol spray products are being used or where oxygen is being administered. Such substances create the danger of combustion and explosion.
- Always follow the console instructions for proper operation.
- Close supervision is necessary when used by, or near children, invalids or disabled persons.
- Do not use this product outdoors, near swimming pools or in areas of high humidity.
- Never operate a Life Fitness product with the air openings blocked. Keep air openings free of lint, hair or any obstructing material.

- Never insert objects into any opening in this product. If an object should drop inside, turn off the power, unplug the power cord from the outlet and carefully retrieve it. If the item cannot be reached, contact Life Fitness Customer Support Services.
- Never place liquids of any type directly on the unit, except in an accessory tray or holder. Containers with lids are recommended.
- Wear shoes with rubber or high-traction soles. Do not use shoes with heels, leather soles, cleats or spikes. Make sure no stones are embedded in the soles. Do not use this product in bare feet. Keep all loose clothing, shoelaces and towels away from moving parts.
- Do not reach into or underneath the unit, or tip it on its side during operation.
- Keep the area six feet (2 meters) by three feet (1 meter) behind the treadmill clear of any obstructions, including walls, furniture, and other equipment.
- Handrails may be held to enhance stability as needed, but are not for continuous use.
- Use the handrails whenever additional stability is required. In case of an emergency, such as tripping, the handrails should be grabbed and the user should place his/her feet on the side platforms.
- Never walk or jog backwards on the treadmill.
- When necessary to immobilize the treadmill, set display to read SELECT A WORKOUT. (Press the STOP key twice if not already there). Then hold down the SPEED DOWN key and press the STOP key. The treadmill now displays IMMOBILIZED. In this state, the treadmill cannot be operated. The main motor and incline are disabled. The treadmill will remain in this state across resets, power cycles, etc. To restore normal operation, repeat the same key sequence: hold down the SPEED DOWN key and press the STOP key. The treadmill will display SELECT A WORKOUT again.
- Use this appliance only for its intended use as described in this manual. Do not use attachments not recommended by the manufacturer.

CAUTION: Risk of injury to persons - To avoid injury, stand on the siderails before starting the treadmill.

WARNING: Activate software lockout when not in use. Refer to Owner's Manual for lockout instructions. Store instructions out of reach of children.

SAVE THESE INSTRUCTIONS FOR FUTURE REFERENCE.

1.2 SETUP

Read this Operation Manual before setting up the Life Fitness Treadmill. Place the treadmill where it will be used before beginning the setup procedure.

ELECTRICAL POWER REQUIREMENTS

The Life Fitness Treadmill is intended for use on a normal 120-Volt electrical circuit in the United States and Canada. The following table provides the current rating for this product based on supply voltage. Make sure that this treadmill model supports the proper line voltage for the installation location before plugging into the outlet.

Supply Voltage (VAC)	Frequency (Hz)	Maximum Current (Amps)
100	50 / 60	14.4
120	50 / 60	12
200	50 / 60	7.2
230	50 / 60	6.3
240+	50 / 60	6.0

GROUNDING INSTRUCTIONS

This Life Fitness product must be properly grounded. If the unit malfunctions or breaks down, proper grounding provides a path of least resistance for the electric current, which reduces the risk of shock to anyone touching or using the equipment. Each unit is equipped with an electrical cord, which includes an equipment grounding conductor and a grounding plug. The plug must be inserted into an outlet that has been properly installed and grounded in accordance with all local codes and ordinances.

A temporary adapter **MUST NOT BE USED** to connect this plug to a two-pole receptacle in North America. If a properly grounded, 12 AMP outlet is not available, a qualified electrician must install one.

DANGER: A risk of electrical shock may result from improper connection of the equipment-grounding conductor. Check with a qualified electrician if in doubt about proper grounding technique. **DO NOT** modify the plug provided with the product. If it will not fit an electrical outlet, have a proper outlet installed by a qualified electrician.

DANGER: Tout branchement incorrect du conducteur de mise à la terre de l'appareil peut causer un risque de décharge électrique. Consulter un électricien qualifié en cas de doute sur la technique de mise à la masse. **NE PAS** modifier la fiche de l'appareil. Si elle ne s'adapte pas sur une prise électrique, faire installer une prise correcte par un électricien qualifié.

HOW TO STABILIZE THE LIFE FITNESS TREADMILL

After placing the unit where it will be used, check its stability. If there is even a slight rocking motion or the unit is not stable, determine which stabilizing leg is not resting on the floor. To adjust, loosen the JAM NUT (A) and turn the STABILIZING LEG (B) until the rocking motion ceases and both stabilizing legs rest firmly on the floor. Retighten the JAM NUT.

NOTE: It is extremely important that the stabilizing leg be correctly adjusted for proper operation. An unbalanced unit may cause the striding belt misalignment.

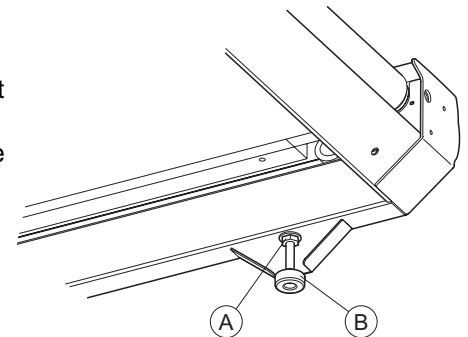

POWER SWITCH

Located on the front panel at the base of the treadmill, the ON/OFF switch has two positions - "I" (one) for ON and "0" (zero) for OFF.

IMMOBILIZING THE TREADMILL

The treadmill can be immobilized if necessary as follows: If the MESSAGE CENTER does not display "SELECT A WORKOUT", press the STOP key twice until that prompt appears. Then, press and hold down the SPEED DOWN key and press the STOP key. The MESSAGE CENTER displays "IMMOBILIZED". The immobilized treadmill cannot be operated, and it remains in this state across resets, power cycles, etc. The main motor and incline are disabled. To restore normal operation, repeat the same key sequence: Press and hold down the SPEED DOWN key, and press the STOP key. The MESSAGE CENTER displays SELECT A WORKOUT, indicating that the treadmill is ready for use.

CENTERING THE BELT

After the treadmill has been installed and leveled, the belt must be checked to confirm proper tracking. First, plug the power cord into a suitable outlet. See the topic titled Electrical Requirements, which appears earlier in this section, for details. Then, turn the treadmill ON.

Stand on the siderails of the treadmill and straddle the belt. Press the GO SYSTEM-QUICK START key and increase the speed to 4.0-mph (6.4 kph) using the SPEED UP ARROW key.

If the striding belt moves to the right, turn the right tension bolt (A) a quarter-turn clockwise with provided quarter-inch Allen wrench, and then turn the left tension bolt a quarter-turn counter-clockwise (see figure). This sets the striding belt tracking back to the center of the roller.

If the striding belt moves to the left, turn the left tension bolt a quarter-turn clockwise and then turn the right tension bolt a quarter-turn counter-clockwise to start striding belt tracking back to the center of the roller.

Repeat adjustments until the striding belt appears centered. The belt should be centered on the roller with an equal distance (B) on both sides from belt to roller. Allow the machine to continue running for several minutes to observe if the tracking remains stabilized.

NOTE: Do not exceed one full turn of the adjusting screws in either direction. If, after one full turn, the belt does not track properly, contact Customer Support Services. The phone numbers are listed in Section 6.4, titled How to Obtain Product Service.

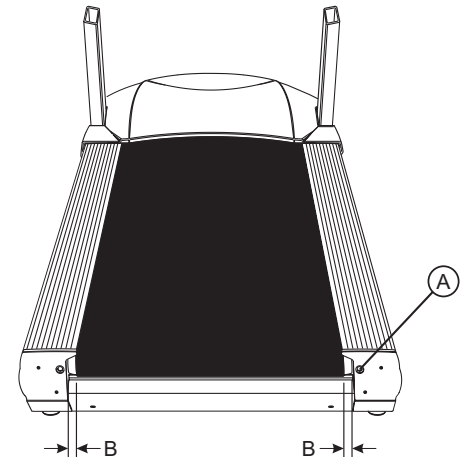

2 THE DISPLAY CONSOLE

2.1 DISPLAY CONSOLE OVERVIEW

The computerized display console on the treadmill allows the user to tailor a workout to personal fitness abilities and goals and to monitor progress. With this easy-to-use console, the user can track fitness improvement from one workout to the next.

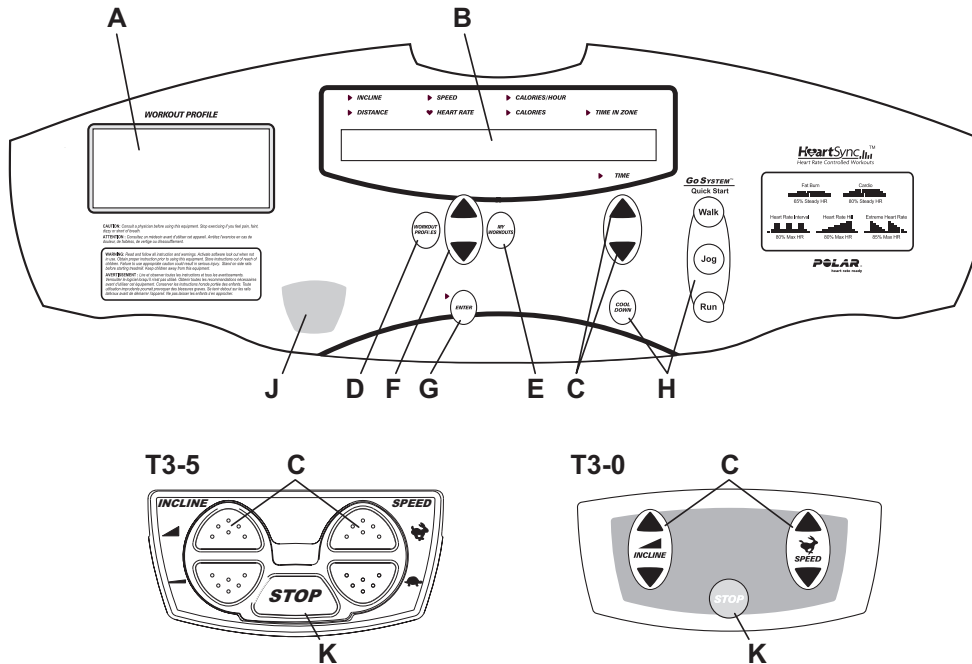

2.2 DISPLAY CONSOLE DESCRIPTIONS

- A. **WORKOUT PROFILE WINDOW:** Displays a matrix of lights representing the upcoming terrain. During a workout, the light columns move across the screen from right to left. The higher the column of lights, the greater the incline and workout intensity.
- B. **MESSAGE CENTER:** Provides step-by-step instructions for setting up workouts. During workouts, displays INCLINE, DISTANCE, SPEED, HEART RATE, CALORIES/HOUR, CALORIES, TIME IN ZONE, and TIME.
- C. **TIME, INCLINE AND SPEED KEYS:** Press these keys to increase or decrease the workout time, the incline of the treadmill deck, or the striding belt speed. In addition, any of these keys may be used to set up, or begin, a workout.
- D. **WORKOUT PROFILES:** Press this key to select FAT BURN, CARDIO, HEART RATE HILL, HEART RATE INTERVAL, EXTREME HR, SPORT TRAINING, 5K SPORT TRAINING, 10K SPORT TRAINING, HILL, RANDOM, MANUAL, and EZ INCLINE, (**T3-5 Only:** 30-MINUTE WALK, 3-MILE JOG, 45-MINUTE CROSS-TRAIN) workouts.
- E. **MY WORKOUT:** The My Workout feature makes it possible to pre-set up to seven workouts with personal setup information, such as age or desired speed, and then store these workouts in the console memory. These workouts are accessed with the MY WORKOUTS key. Any workout can be pre-set and stored, including FAT BURN, CARDIO, HEART RATE HILL, HEART RATE INTERVAL, EXTREME HR, 5K SPORT TRAINING, 10K SPORT TRAINING, HILL, RANDOM, MANUAL, and EZ INCLINE (**T3-5 Only:** 30-MINUTE WALK, 3-MILE JOG, 45-MINUTE CROSS-TRAIN, CUSTOM). Additionally, the CUSTOM workout (**T3-5 Only**), for which the user can set up, edit, and save changed attributes, can be accessed via the MY WORKOUT key.
- F. **ARROW KEYS:** Use these keys to enter data, cycle through and select workouts, and change Target Heart Rate during Zone Training+ workouts.
- G. **ENTER KEY:** Press this key to confirm entries of workout setup values displayed in the MESSAGE CENTER.

H. GO SYSTEM-QUICK START, COOL DOWN KEYS:

GO SYSTEM-QUICK START: This is the fastest way to begin exercising, and it bypasses the steps involved in selecting a specific workout program. Once a GO SYSTEM-QUICK START key is pressed, a MANUAL workout begins.

COOL DOWN: Press this key to begin an automatically customized cool-down protocol.

- J. EMERGENCY STOP SYSTEM:** A cord with a clip is attached to this magnetized key. Before starting a workout, attach the clip to clothing. To stop the striding belt on the treadmill, pull the cord, removing the key from the console. Replace the key to reset the system.

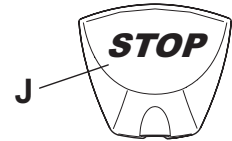

- K. STOP (PAUSE) KEY:** Stops the belt, holds the current workout, and places the unit in PAUSE mode. To resume the workout, press the ENTER key. Press the STOP key twice in succession to terminate the workout.



When the treadmill is in PAUSE mode a count-down clock is displayed. Once this clock times out, the workout terminates. See the Settings topic in the Section 5, titled User Menu, for information on reducing or extending pause time.

2.3 READING RACK

The display console design includes a built-in reading rack, where a book or magazine can be placed during a workout.

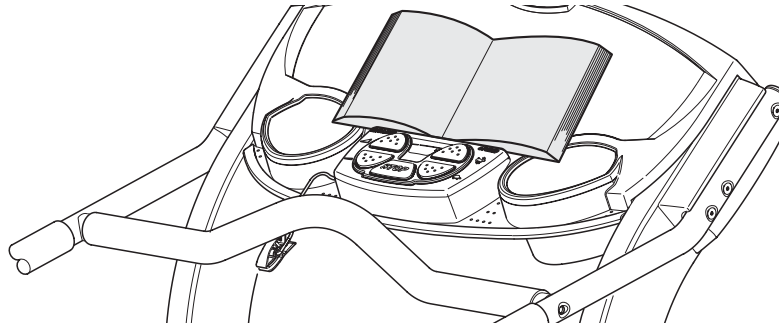

2.4 ACCESSORY TRAYS

The accessory trays are located on either side of the display console.

3 HEARTSYNC™ EXERCISE

3.1 WHY HEARTSYNC™ EXERCISE?

Research shows that maintaining a specific heart rate while exercising is the optimal way to monitor the intensity of a workout and to achieve maximum results. That is the idea behind the Life Fitness HeartSync approach to exercise.

HeartSync identifies an exerciser's ideal heart rate range, or zone, for burning fat or increasing cardiovascular fitness. The values within the zone depend on the workout. The Life Fitness Treadmill features five exclusive workouts designed to take full advantage of the benefits of HeartSync exercise: FAT BURN, CARDIO, HEART RATE HILL™, HEART RATE INTERVAL™, and EXTREME HEART RATE™. Each workout offers different benefits, as discussed in Section 4, titled The Workouts.

NOTE: Consulting a fitness trainer is recommended for defining specific fitness goals and designing a workout program.

All HeartSync workouts measure heart rate. Wear a telemetry chest strap to enable the treadmill's on-board computer to monitor the heart rate during a workout. The computer automatically adjusts the incline level to maintain the target heart rate based on the actual heart rate.

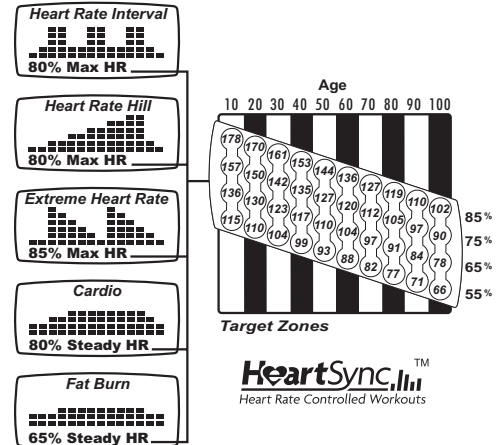

3.2 HEART RATE MONITORING

THE POLAR® HEART RATE CHEST STRAP

The Life Fitness Treadmill is equipped with Polar® telemetry, a heart rate monitoring system in which electrodes, pressed against the the skin, transfer heart rate signals to the treadmill console. These electrodes are attached to a chest strap that the user wears during the workout. The chest strap is standard with the treadmill.

See the diagram below for correct positioning of the strap. The electrodes (A), which are the two grooved surfaces on the underside of the strap, must remain wet to transmit accurately the electrical impulses of the heart back to the receiver. Moisten the electrodes. Then, secure the strap as high under the chest muscles as possible. The strap should be snug, but comfortable enough to allow for normal breathing.

The transmitter strap delivers an optimal heart rate reading when the electrodes are in direct contact with bare skin. However, it functions properly through a thin layer of wet clothing.

If it becomes necessary to re-moisten the chest strap electrodes, grasp the center of the strap, pull it away from the chest to expose the two electrodes, and moisten them.

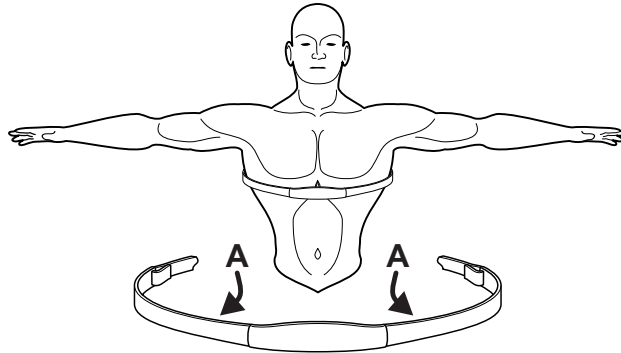

4 THE WORKOUTS

4.1 WORKOUT OVERVIEWS

The following workouts are pre-programmed for the Life Fitness Treadmill.

GO SYSTEM-QUICK START is the fastest way to begin exercising, and it bypasses the steps involved in selecting a specific workout program. Press the WALK, JOG, or RUN key to begin a MANUAL workout at a preset speed.

HILL is an interval training workout. Intervals are periods of intense aerobic exercise separated by regular periods of lower-intensity exercise.

RANDOM is an interval training workout of constantly changing intensity levels that occur in no regular pattern or progression.

MANUAL is a workout in which the intensity level does not change automatically.

EZ INCLINE is an incline-based workout. The gradual changes in elevation are extremely subtle, lowering perceived exertion.

SPORT TRAINING™ simulates outdoor conditions that a runner™ would experience.

5K SPORT TRAINING™ simulates an actual terrain with varying incline levels. It is designed to assist runners in training for a 5-kilometer (3.1-mile), race.

10K SPORT TRAINING™ simulates an actual terrain with varying incline levels. It is designed to assist runners in training for a 10-kilometer, (6.2-mile), race.

FAT BURN is a low-intensity workout for burning the body's fat reserves. The user must wear a heart rate chest strap. The workout program automatically adjusts the intensity level, based on the actual heart rate, to maintain the recommended rate at 65 percent of the theoretical maximum†.

CARDIO is a higher intensity workout for more fit users, emphasizing cardiovascular benefits and maximum fat burning. The user must wear a heart rate chest strap. The workout program automatically adjusts the intensity level, based on the actual heart rate, to maintain the recommended rate at 80 percent of the theoretical maximum.

HEART RATE HILL takes the user through three different intensity levels based on the target heart rate*. The user must wear a heart rate chest strap.

HEART RATE INTERVAL alternates between two intensity levels based on the target heart rate. The user must wear a heart rate chest strap.

EXTREME HEART RATE is an intense workout for more experienced users. It is designed to bring the heart rate up and down as quickly as possible. The user must wear a heart rate chest strap.

T3-5 Only:

30-MINUTE WALK is ideal for beginning exercisers or regular walkers.

3-MILE JOG is an ideal next step for users who no longer derive a sufficient workout from the 30-minute walk program.

45-MINUTE CROSS-TRAIN is a complete, varied workout designed to reduce the risk of stress-related injuries that can result from workouts limited to one, repetitive activity.

† Defined by the American College of Sports Medicine's "Guidelines for Exercise Testing and Prescription" as being equal to 220 minus an individual's age.

* Target Heart Rate (THR) is a percentage of the theoretical maximum. For example, a 40-year-old user's recommended THR for the HEART RATE HILL workout is 144. The HEART RATE HILL workout targets 80 percent of the maximum, so the equation would be $(220-40) \cdot 80 = 144$.

4.2 SETTING UP WORKOUTS

The chart below lists the steps for setting up each workout program, except for those stored under the MY WORKOUT key. See section 4.4, titled My Workout, and section 4.5, titled Custom Workout (**T3-5 Only**), for more information.

At the MESSAGE CENTER prompt to select a workout, press the WORKOUT PROFILE key repeatedly, and press ENTER when the name of the desired workout appears. Or, press the WORKOUT PROFILE key once. Then, press the ARROW keys to scroll through displayed options, and press ENTER when the name of the desired workout appears. Afterward, the MESSAGE CENTER displays prompts for workout setup information, such as weight and desired speed. At each prompt, use the ARROW keys to scroll to the desired value, and press ENTER. Then, begin the workout. Press the ARROW keys to change values while the workout is in progress. To switch programs "on the fly," press the WORKOUT PROFILES key repeatedly until the desired new workout appears. Then press ENTER. To stop a workout, use the EMERGENCY STOP SYSTEM, or press the STOP key.

NOTE: The treadmill is intermittent-duty equipment. See the Lift Motor: Maximum duty cycle of operation entry in Section 7, titled Treadmill Specifications.

† Or accept the displayed value.

LIFE FITNESS TREADMILL WORKOUT SETUP STEPS

GO SYSTEM-QUICK START™

Press GO SYSTEM-QUICK START
WALK, JOG, or RUN
Begin workout

HILL

Press WORKOUT PROFILE
Select HILL
Enter weight
Select time
Select level
Select speed
Begin workout

RANDOM

Press WORKOUT PROFILE
Select RANDOM
Enter weight
Select time
Select level
Select speed
Begin workout

MANUAL

Press WORKOUT PROFILE
Select MANUAL
Enter weight
Select time
Enter incline
Select speed
Begin workout

EZ INCLINE™

Press WORKOUT PROFILE
Select EZ INCLINE
Enter weight
Select time
Select level
Select speed
Begin workout

SPORT TRAINING™

Press WORKOUT PROFILE
Select SPORT TRAINING
Enter weight
Select time
Select level
Select speed
Begin workout

5K SPORT TRAINING™

Press WORKOUT PROFILE
Select 5K SPORT TRAINING
Enter weight
Select level
Select speed
Begin workout

10K SPORT TRAINING™

Press WORKOUT PROFILE
Select 10K SPORT TRAINING
Enter weight
Select level
Select speed
Begin workout

FAT BURN

Press WORKOUT PROFILE
Select FAT BURN
Enter weight
Select time
Enter age
Enter THR†
Select speed
Begin workout

CARDIO

Press WORKOUT PROFILE
Select CARDIO
Enter weight
Select time
Enter age
Enter THR†
Select speed
Begin workout

HEART RATE HILL™

Press WORKOUT PROFILE
Select HEART RATE HILL
Enter weight
Select time
Enter age
Enter THR†
Select speed
Begin workout

HEART RATE INTERVAL™

Press WORKOUT PROFILE
Select HEART RATE INTERVAL
Enter weight
Select time
Enter age
Enter THR†
Select speed
Begin workout

EXTREME HEART RATE™

Press WORKOUT PROFILE
Select EXTREME HR
Enter weight
Select time
Enter age
Enter THR†
Enter walk speed
Enter jog speed
Begin workout

Daily Training Workout (T3-5 Only)

30-MINUTE WALK

Press WORKOUT PROFILE
Select 30-MINUTE WALK
Enter weight
Select level
Select speed
Begin workout

3-MILE JOG

Press WORKOUT PROFILE
Select 3-MILE JOG
Enter weight
Select level
Select speed
Begin workout

45-MINUTE CROSS-TRAIN

Press WORKOUT PROFILE
Select 45-MINUTE X-TRAIN
Enter weight
Select level
Select walk speed
Select jog speed
Begin workout

4.3 WORKOUT DESCRIPTIONS

GO SYSTEM-QUICK START

This is the fastest way to begin exercising, and it bypasses the steps involved in selecting a specific workout program. Press one of the GO SYSTEM-QUICK START keys to begin a MANUAL workout at a preset speed:

	English Units	Metric Units
WALK	3.0 mph (0.5-4)	5,0 kph (0,8-6,5)
JOG	5.0 mph (0.5-7)	8,0 kph (0,8-11,0)
RUN	7.0 mph (0.5-10/12)	11,0 kph (0,8-16/20)

These speeds can be changed. To do so, use the SPEED ARROW keys to adjust the speed value displayed in the MESSAGE CENTER. Then, press, and hold down the WALK, JOG, or RUN key until the console beeps twice, indicating that the new speed has been programmed. When the WALK, JOG, and RUN keys are used to select, or change, a speed, the MESSAGE CENTER displays the new speed.

NOTE: All changed preset values are lost when the treadmill is turned off.

HILL

The Life Fitness-patented HILL workout offers a variety of configurations for interval training. Intervals are periods of intense aerobic exercise separated by regular periods of lower-intensity exercise. The WORKOUT PROFILE window represents these high and low intervals as columns of light, which together have the appearance of hills and valleys. The computerized interval training workout has been scientifically demonstrated to promote greater cardio-respiratory improvement than steady-pace training.

The HILL workout goes through four phases, each marked by different intensity levels. The WORKOUT PROFILE window displays the progress of these phases. As noted in the descriptions below, the heart rate should be measured at two stages in the workout to gauge its effectiveness. Wear the the chest strap.

- 1 Warm-up is a phase of low, gradually rising resistance, which brings the heart rate into the lower end of the target zone and increases respiration and blood flow to working muscles.
- 2 Plateau increases the intensity slightly, and keeps it steady, to bring the heart rate to the low end of the target zone. Check the heart rate at the end of this phase.
- 3 Interval Training is a series of increasingly steeper hills, alternating with valleys, or stints of recovery. The heart rate should rise to the high end of the target zone. Check the heart rate at the end of this phase.
- 4 Cool-down is a low-intensity phase that allows the body to begin removing lactic acid, and other exercise by-products, which build up in muscles and contribute to soreness.

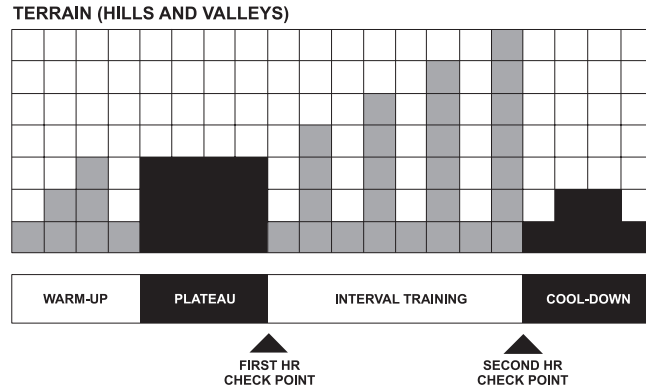

Each column, as seen in the **WORKOUT PROFILE WINDOW** and the chart above, represents one interval. The overall duration of the workout determines the length of each interval.

1 to 9 minutes: A workout with a duration of less than 10 minutes is insufficient for the Hill program to complete all four phases adequately. The program, therefore, condenses a workout of this duration at various stages.

10 to 19 minutes: The interval durations initially are set at 30 seconds for a 10-minute workout. For every minute over 10, each interval increases by three seconds. A 15-minute workout consists of 20 intervals at 45 seconds each.

20 to 99 minutes: All intervals last 60 seconds. If the user adds minutes to the pre-set duration while the workout is in progress, the program adds hills and valleys that are identical to the first eight intervals of the Interval Training phase. This pattern repeats until the workout is completed.

RANDOM

The RANDOM program creates a terrain of hills and valleys that varies with each workout. More than one million different patterns are possible.

MANUAL

During a MANUAL workout, the program does not automatically change speed, incline, or time duration, as selected by the user during the workout setup. The user can increase or lower these values, using the ARROW keys.

EZ INCLINE WORKOUT™

In this incline-based workout, the gradual changes in elevation are extremely subtle, lowering perceived exertion. The cardiovascular workout is effective, efficient, and enjoyable at the same time.

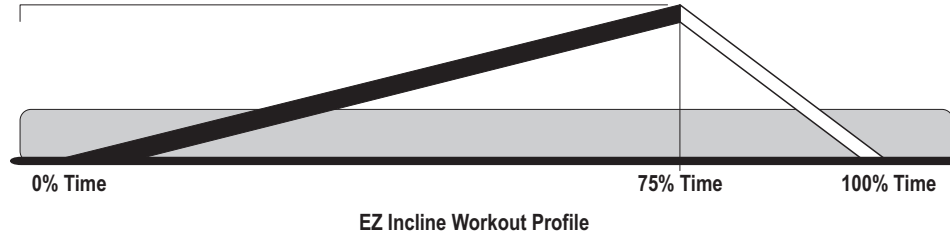

The program consists of one hill. The user determines the elevation of the peak during the setup. This peak is reached after 75 percent of the workout is completed. Afterward, the incline gradually returns to zero percent.

NOTE: For workouts that are longer than 16 minutes, the level can be changed to any desired value. For workouts that are shorter than 16 minutes, the the level selection is limited.

SPORT TRAINING WORKOUT™

This program simulates outdoor conditions that a runner would experience. The baseline level is a 1.5-percent grade, which simulates running on flat ground. A zero-percent grade simulates running downhill. Inclines last between 30 and 60 seconds.

5K SPORT TRAINING WORKOUT™

This program simulates conditions that a runner would experience when training for a 5-kilometer race. The workout ends after the user completes 5 kilometers (3.1 miles).

10K SPORT TRAINING WORKOUT™

This program simulates conditions that a runner would experience when training for a 10-kilometer race. The workout ends after the user completes 10 kilometers (6.2 miles).

HEARTSYNC™ + WORKOUTS

During the setup for each of these workouts, the treadmill computer calculates a target heart rate* based on age and the workout type. The MESSAGE CENTER displays this target rate and prompts the user to accept or change it. The workout program uses this value as the upper heart rate within the target zone. The computer then calculates the lower value of the zone, based, again, on the selected program. The user wears a chest strap throughout the workout, enabling the computer to track the length of time spent in the target zone. If the heart rate goes above the theoretical maximum† for more than 45 seconds, the treadmill automatically goes into pause mode. HeartSync workouts include: FAT BURN, CARDIO, HEART RATE HILL, HEART RATE INTERVAL, and EXTREME HEART RATE.

FAT BURN

This workout is designed to maintain a recommended target heart rate at 65 percent of the theoretical maximum† for optimal results. Throughout the workout, the user wears a chest strap. The console continuously monitors and displays the heart rate, adjusting the intensity level of the treadmill to reach and maintain the target. This system eliminates over- and under-training, and it maximizes the aerobic benefits of exercise by using the body's fat stores for fuel.

CARDIO

This is a higher-intensity workout for more fit users, emphasizing cardiovascular benefits and maximum fat burning. It is virtually identical to FAT BURN, except that the recommended target heart rate is calculated at 80% of a theoretical maximum to place a heavier workload on the heart muscle.

NOTE: Change the target heart rate at any time during a workout by using the ARROW keys.

HEART RATE HILL™

This program combines the standard HILL workout profile with a HeartSync workout. It consists of three hills that target three heart rate goals: The first hill brings the heart rate to 90 percent of the target rate. The second hill increases the rate to 95 percent. The third hill matches the target heart rate. The valley always is defined as 85 percent of the target.

After a standard three-minute warm-up, the workout progresses toward the first hill and heart rate goal. Once the user reaches 90 percent of the target heart rate, the hill continues for one minute. Then, the goal switches to 85 percent of the target heart rate. When the user's heart rate falls to that goal, the valley continues for one minute. Then, the goal switches to 95 percent of the target heart rate. When the user reaches that goal, the hill continues for one minute. As the chart at the top of the following page illustrates, this pattern continues for all three hills. After the user completes the third hill/valley pair, the program returns to the first hill and heart rate goal, and the sequence repeats as long as the duration allows. The user's fitness level determines the number of hills and valleys encountered. At the end of the duration, the workout goes into a cool-down phase.

If the user does not reach a heart rate goal after five minutes, the MESSAGE CENTER displays a prompt to increase or decrease speed, depending on whether the workout is in a hill or valley phase. The program does not proceed to a new heart rate goal until the user reaches the current goal.

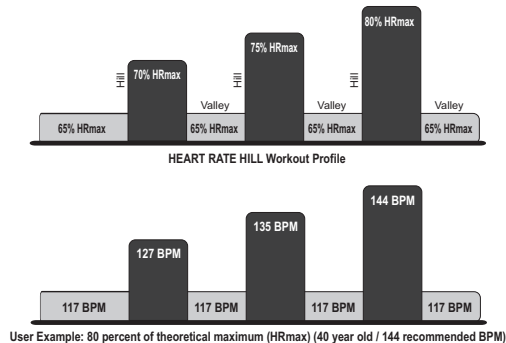

† Defined by the American College of Sports Medicine's "Guidelines for Exercise Testing and Prescription" as being equal to 220 minus an individual's age.

* Target Heart Rate (THR) is a percentage of the theoretical maximum. For example, a 40-year-old user's recommended THR for the FAT BURN workout is 117. The FAT BURN workout targets 65 percent of the maximum, so the equation would be $(220-40) \cdot .65=117$.

HEART RATE INTERVAL™

This program also combines the standard HILL workout profile with a HeartSync workout. It alternates between a hill, which brings the heart rate up to the target rate*, and a valley, which brings the heart rate down to 90 percent of the target. After a standard three-minute warm-up, the workout progresses toward the first hill and heart rate goal. When the goal is reached, the hill continues for three minutes. Then, the goal switches to 90 percent of the target heart rate. When the user's heart rate falls to that goal, the valley continues for three minutes. Then, the program switches back to the target heart rate goal. This pattern continues throughout the duration. The user's fitness level determines the number of hills and valleys encountered. At the end of the duration, the workout goes into a cool-down phase.

If the user does not reach a heart rate goal after five minutes, the MESSAGE CENTER displays a prompt to increase or decrease speed, depending on whether the workout is in a hill or valley phase. The program does not proceed to a new heart rate goal until the user reaches the current goal.

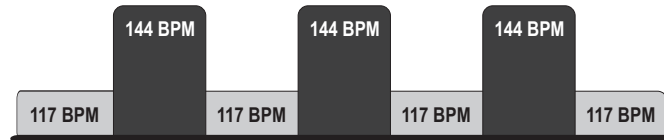
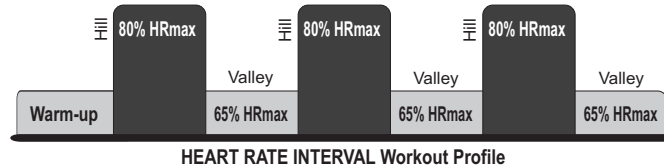

* Target Heart Rate (THR) is a percentage of the theoretical maximum. For example, a 40-year-old user's recommended THR for the HEART RATE INTERVAL workout is 144. The HEART RATE INTERVAL workout targets 80 percent of the maximum, so the equation would be $(220-40) \cdot .80 = 144$.

EXTREME HEART RATE™

This intense, varied workout is designed to help more experienced users to break through fitness improvement plateaus. The workout alternates between two target heart rates* as quickly as possible. The effect is similar to that of running sprints.

When setting up the workout, the user enters a target heart rate and selects a walk speed and a jog speed. After a standard three-minute warm-up, the treadmill accelerates to the jog speed, and the incline increases, until the user reaches the target heart rate goal. That target rate is maintained for a stabilizing period. Then, the incline is reduced to 0 percent, and the treadmill slows to the walk speed. When the heart rate falls to the 75 percent goal, it is maintained there for a stabilizing period. The program repeats the alternating of speeds and incline levels, continuing this pattern throughout the duration. The user's fitness level determines the number of repetitions. At the end of the duration, the workout goes into a cool-down phase.

If the user does not reach a heart rate goal after five minutes, the MESSAGE CENTER displays a prompt to increase or decrease speed, depending on whether the workout is in a hill or valley phase. The program does not proceed to a new heart rate goal until the user reaches the current goal.

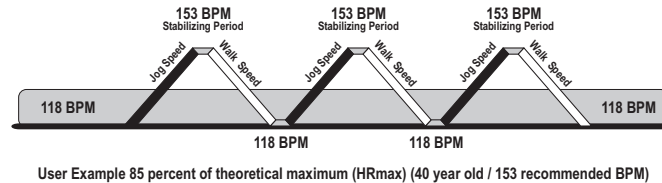
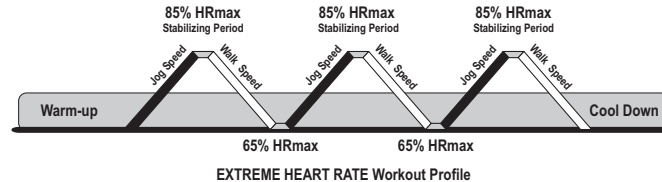

* Target Heart Rate (THR) is a percentage of the theoretical maximum. For example, a 40-year-old user's recommended THR for the EXTREME HEART RATE workout is 144. The EXTREME HEART RATE workout targets 85 percent of the maximum, so the equation would be $(220-40) \cdot .85=144$.

30-MINUTE WALK (T3-5 ONLY)

This workout is ideal for beginning exercisers or regular walkers. At the start of the program, the treadmill runs for five minutes at 1 MPH below the selected speed. Afterward, the program automatically adjusts the speed in .5 MPH increments, and changes the incline percentage as seen in the table below. The program concludes with a five-minute cool-down.

- After selecting the 30-MINUTE WALK program and entering the weight, use either the SPEED or INCLINE keys to select a maximum speed between 2.0 and 4.5 MPH (3.2 and 7.2 KPH), and press ENTER.
- After selecting a maximum speed, choose an effort level, using the ARROW keys, and press ENTER.

The speed and level can be changed at any time during the workout; however, manual changes in speed are overridden by those scheduled in the program.

30-Minute Walk Program			
Speed		Incline	
Time (minutes)	Change (MPH/KPH)	Time (minutes)	Change (%) based on level
5.0	+0.5 / +0.81	7.5	+0.1 to +1.6
10.0	+0.5 / +0.81	12.5	+0.1 to +1.5
20.0	-0.5 / -0.81	22.5	-0.1 to -1.5
25.0	-0.5 / -0.81	27.5	-0.1 to -1.6
30.0	Cool-down begins; decrease varies with speed selected		

Percent incline changes are lower at lower levels and higher at higher levels.

3-MILE JOG (T3-5 ONLY)

This workout is an ideal next step for users who no longer derive a sufficient workout from the 30-MINUTE WALK program. At the start of the program, the treadmill runs for five minutes at 1.5 MPH below the selected speed. Afterward, the program automatically adjusts the speed and changes the incline percentage as seen in the table on the following page. The program concludes with a five-minute cool-down.

- After selecting the 3-MILE JOG program and entering the weight, use either the SPEED or INCLINE keys to select a maximum speed between 4.0 and 7.0 MPH (6.4 - 11.2 KPH), and press ENTER.
- After selecting a maximum speed, choose an effort level using the ARROW keys, and then press ENTER.

The speed and level can be changed at any time during the workout; however, manual changes in speed are overridden by those scheduled in the program.

3-Mile Jog Program

Speed		Incline	
Distance (miles/km)	Change (MPH/KPH)	Distance (miles/km)	Change (%) based on level
0.50/0.81	-0.50 / -0.81	1.00/1.60	+0.1 to +1.6
0.75/1.21	+2.0 / +3.22	1.25/2.01	-0.1 to -1.6
1.25/2.01	-2.0 / -3.22	1.75/2.82	+0.7 to +4.8
1.50/2.42	+1.0 / -1.61	2.00/3.22	-0.7 to -4.8
2.00/3.22	-1.0/-1.61	2.50/4.03	+0.5 to +3.3
2.25/3.62	+1.5/+2.42	2.75/4.43	-0.5 to -3.3
2.75/4.43	-1.5/-2.42		

Percent incline changes are lower at lower levels and higher at higher levels.

45-MINUTE CROSS-TRAIN (T3-5 ONLY)

Cross-training is a complete, varied workout designed to reduce the risk of stress-related injuries that can result from workouts limited to one, repetitive activity. Competitive athletes use cross-training to keep their bodies in premier condition between seasons or events, as well as to prepare for competition. The workout alternates between user-selected walk and jog speeds, beginning with a walk-speed interval. The chart below lists the maximum and minimum speed and incline changes. The program concludes with a five-minute cool-down.

- After entering weight during the setup, use either the SPEED or INCLINE ARROW keys to select a maximum walk speed, between 2.0 and 4.5 MPH (3.2 and 7.2 KPH), and press ENTER.
- Use either the SPEED or INCLINE keys to select a maximum jog speed, between 4.0 and 7.0 MPH (6.4 and 11.2 KPH), and press ENTER.
- After selecting maximum walk and jog speeds, select a level, using the ARROW keys, and press ENTER.

The speed and level can be changed at any time during the workout; however, manual changes in speed are overridden by those scheduled in the program.

45-Minute Cross-Train Program			
Speed		Incline	
Time (minutes)	Change (MPH/KPH)	Time (minutes)	Change (%) based on level
5.0	Jog	5.0	-0.9 to -9.5
10.0	Walk	10.0	+0.5 to +3.1
20.0	Jog	15.0	+0.4 to +6.4
25.0	Walk	20.0	-0.9 to -9.5
35.0	Jog	25.0	+0.6 to +3.1
40.0	Walk	30.0	+0.3 to +6.4
45.0	Cool-down	35.0	-0.9 to -9.5
		40.0	+0.6 to +3.1

Percent incline changes are lower at lower levels and higher at higher levels.

COOL-DOWN

Life Fitness' unique Cool-down Protocol automatically customizes every cool-down based on the workout performance. Factors such as speed, incline, duration and heart rate determine the duration and intensity of the cool-down.

4.4 MY WORKOUT

The My Workout feature on the T7i treadmill makes it possible to pre-set up to seven workouts with personal setup information, such as age or desired speed, and then store the workouts in the console memory. These workouts are accessed with the MY WORKOUTS key.

Any workout can be pre-set and stored, including FAT BURN, CARDIO, HEART RATE HILL, HEART RATE INTERVAL, EXTREME HR, 5K SPORT TRAINING, 10K SPORT TRAINING, HILL, RANDOM, MANUAL, and EZ INCLINE (**T3-5 Only**: 30-MINUTE WALK, 3-MILE JOG, 45-MINUTE CROSS-TRAIN).

USING A WORKOUT SAVED UNDER MY WORKOUTS

Press the MY WORKOUT key. Scroll through the names displayed in the MESSAGE CENTER, either by pressing the MY WORKOUT key repeatedly or by pressing the ARROW keys. When the desired name appears, press ENTER. The workout then begins.

All seven workouts are set to the same, default, manual workout program "out of the box." By factory default, the workouts are stored under the names WORKOUT 1 through WORKOUT 7. See the following section for steps to change workouts stored under MY WORKOUT.

EDITING SETTINGS FOR WORKOUTS SAVED UNDER MY WORKOUT

Use the following steps to change settings for a stored workout or to change a workout name.

1. Press the MY WORKOUT key.
2. Scroll through the user names displayed in the MESSAGE CENTER, either by repeatedly pressing the MY WORKOUT key or by pressing the ARROW keys.
3. When the desired name appears, press and hold the ENTER key until the console beeps twice.
4. The MESSAGE CENTER displays the prompt, "PRESS WORKOUT PROFILES KEY TO REPROGRAM WORKOUT OR PRESS MY WORKOUT KEY TO EDIT YOUR NAME". At this prompt, change the workout settings, or change the workout name.

To change a settings for a stored workout:

5. Press the WORKOUT PROFILES key.
6. The MESSAGE CENTER displays the prompt, "REPROGRAM WORKOUT MODE - SELECT WORKOUT NOW." Scroll through the workouts displayed in the MESSAGE CENTER, either by repeatedly pressing the WORKOUT PROFILES key or by pressing the ARROW keys. When the desired workout appears, press ENTER.
7. Enter setup information as prompted by the MESSAGE CENTER. Use the ARROW keys to scroll through displayed values, and press ENTER to confirm the desired value. Once all information is entered, the MESSAGE CENTER displays WORKOUT SAVED.

To exit the "reprogramming" mode at any time without saving the workout changes, press the STOP key twice.

To change a workout name or User Name

5. Press the MY WORKOUT key.
6. The MESSAGE CENTER displays the prompt, "SELECT LETTER USING MY WORKOUT KEY AND CHANGE LETTERS USING ARROW KEYS." The workout name appears in the MESSAGE CENTER, with the first letter blinking. Scroll to the desired letter, number, or punctuation symbol, using the arrow key. When the desired character appears, press MY WORK-OUT to move on to the next letter. Repeat this step for all characters.
7. Press ENTER to save the new name. The MESSAGE CENTER displays, "USER NAME SAVED."

To exit this mode without saving the name change, press the STOP key twice.

TIP: The User Statistics feature, which stores workout statistics, identifies each stored workout as a "User Name." By factory default, the workouts are stored under the names WORKOUT 1 through WORKOUT 7. It may be desirable to assign user names to the workouts. See Section 5, titled User Menu, for more information.

4.5 CUSTOM WORKOUT (T3-5 ONLY)

It is possible to set up a customized workout on the treadmill and store it in the console memory. Customization involves selecting one of four workout types and setting values for various attributes, such as the workout

goal, to suit personal preferences. Once a CUSTOM workout is saved, it can be accessed through the MY WORKOUT key.

USING A CUSTOM WORKOUT

To select the CUSTOM workout, press the MY WORKOUT key repeatedly until the MESSAGE CENTER displays "CUSTOM." Then, press ENTER. The workout begins immediately. If the CUSTOM program has not been edited, the user does not experience any automatic changes during the workout. See the following section for instructions.

EDITING CUSTOM WORKOUT SETTINGS

Press the MY WORKOUT key repeatedly until the MESSAGE CENTER displays "CUSTOM." Press, and hold down, the ENTER key until the console beeps twice, indicating that the custom program is in "edit" mode.

At the MESSAGE CENTER prompt, select a program type to be customized, using the ARROW keys. Options include, HILL, RANDOM, MANUAL, or HEART RATE, which is a HeartSync workout. For more information, see Section 3, titled HeartSync Exercise. When the desired option appears, press ENTER.

The MESSAGE CENTER then displays prompts to set values for various attributes. See the chart below. For each attribute, scroll through values displayed in the MESSAGE CENTER, and press ENTER to select desired values. After the speed value is entered, the workout begins. While a CUSTOM workout is in progress, it is possible make changes in workout attributes, including:

- Speed
- Incline
- Level
- Target Heart Rate

The treadmill computer memory can save at least 20 changes. When memory is used up, and the computer cannot save any further changes, the console emits two short beeps at the user's next attempt to save a change, indicating that no more changes can be saved.

HILL

Select Goal (time, distance, or calories)
Set value for goal
Enter weight
Select level
Select speed

RANDOM

Select Goal (time, distance, or calories)
Set value for goal
Enter weight
Select level
Select speed

MANUAL

Select Goal (time, distance, or calories)
Set value for goal
Enter weight
Select incline percentage
Select speed

HEART RATE

Select Goal (time, distance, or calories)
Set value for goal
Enter weight
Enter age
Enter Target Heart Rate or accept displayed value
Select speed

4.6 SELECTING AN INTENSITY LEVEL

The steps for setting up a HILL or RANDOM workout include selecting a level. The word "level" refers to a range of incline percentages. The treadmill features 20 levels, with Level 1 having the lowest average incline grade and Level 20 having the highest.

LEVEL	% Incline	LEVEL	% Incline
1	0.0 - 1.5	11	2.0 - 8.5
2	0.0 - 2.2	12	3.0 - 9.2
3	0.0 - 2.9	13	3.5 - 9.9
4	0.0 - 3.6	14	5.0 - 10.6
5	0.0 - 4.3	15	5.5 - 11.3
6	0.0 - 5.0	16	6.5 - 12.0
7	0.0 - 5.7	17	7.0 - 12.7
8	0.0 - 6.4	18	8.0 - 13.4
9	0.5 - 7.1	19	8.7 - 14.1
10	1.5 - 7.8	20	9.0 - 15.0

Within each level are seven incline percentages, or hills. During a workout, each hill appears in the WORKOUT PRO-FILE window as rows of light stacked in a column. The number of lit rows within a column corresponds to an incline percentage. For example, in Level 5, the lowest incline is 0.0 percent and is represented as one lit row. The highest incline, 4.3 percent, is represented by a column with all seven rows lit.

In the HILL and RANDOM workouts, these varying hills occur for equal durations, as discussed in the HILL workout description in Section 4. It is possible to change the incline percentage manually, but the change remains in effect only for the duration of the hill in question. When the workout program brings up a new hill, the incline percentage changes automatically to match that hill.

To change levels during a workout, use the ARROW keys.

During the EZ INCLINE workout, the number of the selected level equals the height of the hill, expressed as an incline percentage. For example, at Level 5, the peak of the hill is at a 5.0%.

5 USER MENU

The USER MENU makes it possible to change certain settings in the treadmill software

5.1 ENTERING AND USING THE USER MENU

Enter the USER MENU BY using one of two procedures:

Press the STOP key twice, and then hold down the ENTER key. The unit goes through a "warm" reset and beeps three times, indicating that the USER MENU has been activated.

OR, hold down the ENTER key, and turn the treadmill on. The message "USER MENU" will appear. After about one second, the MESSAGE CENTER displays the first menu item.

Use the ENTER key to scroll forward through the menu items. Use the STOP key to scroll backwards. There are two ways to exit the menu: Press the STOP key continuously to return to the beginning of the menu; OR switch off the treadmill. Doing so causes all settings to be saved.

5.2 USER MENU ITEMS

USER STATISTICS

The User Statistics mode is used to display the current, accumulated statistics of the workouts stored under the My Workouts feature. See Section, 5.3, titled Description Of User Menu Items.

To access statistics for a specific stored workout, press the MY WORKOUT key repeatedly until the name of that stored workout appears in the MESSAGE CENTER. Then, press ENTER. Or, press the MY WORKOUT key once, and then use the ARROW keys to scroll through the names. When the desired name appears, press ENTER.

Use the TIME ARROW keys to scroll backward and forward through the statistics. If the value for any statistical item is greater than the listed maximum, the MESSAGE CENTER displays dashes, "----".

To clear statistics to zero: Press the SPEED UP ARROW key. The MESSAGE CENTER displays, "PRESS SPEED DOWN ARROW KEY TO CLEAR STATS". Press the SPEED DOWN ARROW key. The statistics are cleared, and the MESSAGE CENTER displays, "STATS CLEAR". If any other key is pressed after the SPEED UP ARROW is pressed, the console cancels the clearing of the statistics. To re-activate the clearing process, press the SPEED UP ARROW key again.

SETTINGS

The values for three settings can be adjusted and saved: Pause Time, Sleep Time, and Units. Cycle through the settings using the UP and DOWN ARROW keys. Use the TIME ARROW keys to change the settings. Any adjustments are saved automatically. Revert a setting back to its default value by pressing the COOL DOWN key

SOFTWARE VERSION NUMBERS

Use the UP and DOWN ARROW keys to toggle between displays of the current software version for the console, and for the Motor Controller. The MESSAGE CENTER displays the Console Software Version number as "CONSOLE VER=XX.X", where xx.x is the version number. For the Motor Controller, the MESSAGE CENTER displays "MOTOR VER = XX.X".

Setting	Default Value	Range	Description
USER STATISTICS			Mode displays accumulated statistics of up to seven different users.
Select User			Use ARROW keys to select 1 of 7 users. †
(T3-5) My Workout 1-7 (T3-0) My Workout 1-4	MY WORKOUT X		Press ENTER to access accumulated statistics of the selected user.
STATISTICS			
MILES:		XXXX:XX	Total accumulated distance - displayed in miles, and percentage of miles.
CALS:		XXXXXXXX	Total accumulated workout calories.
TIME:		XXXX.XX	Total accumulated workout time - displayed in hours: minutes.
SETTINGS			Mode allows 3 settings to be adjusted and saved.
PAUSE TIME:	5	1-99	Default number of minutes that a workout can be paused. Override (reduce or extend PAUSE time) using the TIME ARROW keys during a workout.

SLEEP TIME:	Off	Off-99	Without user activity, treadmill goes into Sleep Mode after a preset time (range is from 1 to 99 minutes). To conserve power, the MESSAGE CENTER and WORKOUT PROFILE go blank, except for a single indicator. To start a workout while in Sleep mode, press any key. To disable, set to off.
UNITS:	English	English/ Metric	Sets the units of weight, speed and distance in English, or Metric.
SOFTWARE VERSION NUMBERS		Mode shows software version for console and motor controller.	
CONSOLE VER:		XX.X	Displays software version for the console board.
MOTOR VER:		XX.X	Displays software version for the motor controller board.

† If user name is already programmed, it will be displayed instead of "MY WORKOUT X."

6 SERVICE AND TECHNICAL DATA

6.1 PREVENTATIVE MAINTENANCE TIPS

The Life Fitness T3-0 and T3-5 treadmills is backed by the engineering excellence and reliability of Life Fitness and is one of the most rugged and trouble-free pieces of exercise equipment on the market today. Commercial Life Fitness treadmills are among the most popular of aerobic trainers, regularly standing up to marathon use - 18 hours a day, 7 days a week - in health clubs, colleges and military facilities the world over. This same technology, engineering expertise, and reliability has gone into the Life Fitness T-Series treadmills.

NOTE: Safety of the equipment can be maintained only if the equipment is examined regularly for damage or wear. Keep the equipment out of use until defective parts are repaired or replaced. Pay special attention to parts that are subject to wear, as outlined below.

The following preventive maintenance tips will keep the Life Fitness treadmill operating at peak performance:

- Clean the display console and all exterior surfaces regularly with mild soap and water or a mild household cleaner. DO NOT use paper towels, ammonia or acid based cleaners. *
- Check operation of the Emergency Stop System once a week.
- Check the operation of the Stop key once a week.
- Inspect and vacuum the area under unit regularly.
- Vacuum around the striding belt regularly to keep debris from accumulating.
- Inspect exterior parts regularly for wear, particularly the striding belt and deck.
- Check the position (centering) of the striding belt.

The optimum operating position of the striding belt is from 1.75" (45 mm) to 2.25" (57 mm) from either side of the frame. If the striding belt travels beyond this position, see How to Adjust and Tension the Striding Belt or contact Life Fitness Customer Support Services for proper alignment instructions, 1-800-328-9714 (USA).

***NOTE:** When cleaning the exterior of the unit, a non-abrasive cleaner and soft cotton cloth are strongly recommended. At no time should cleaner be applied directly to any part of the equipment; use non-abrasive cleaner on a soft cloth and then wipe the unit.

6.2 TROUBLESHOOTING THE HEART RATE CHEST STRAP

HEART RATE READING IS ERRATIC OR ABSENT ENTIRELY

- Repeat the electrode wetting procedure (see How to Use the Heart Rate Monitor Chest Strap). The electrodes must be wet to pick up and transmit accurate heart rate readings.
- Make sure the electrodes are flat against the skin.
- Wash the belt transmitter regularly with mild soap and water.
- Make sure the chest strap transmitter is within three feet (one meter) of the heart rate receiver.
- The chest strap is battery operated and will eventually stop functioning. If the chest strap transmitter battery is depleted, contact Life Fitness Customer Support Services at 1-800-328-9714 for instructions on how to have the chest strap replaced.

HEART RATE READING IS ERRATIC OR EXTREMELY HIGH

When exercising with the heart rate chest strap, you may come within range of electromagnetic signals strong enough to cause abnormally elevated heart rate readings. Possible sources of such signals include:

- Television sets and/or antennas, cell phones, computers, cars, high voltage power lines, and other motor driven equipment.
- Another heart rate transmitter within three feet (one meter) may also cause abnormal heart rate readings.

6.3 HOW TO ADJUST AND TENSION THE STRIDING BELT ON THE LIFE FITNESS TREADMILL

Do not move treadmill or place hands under treadmill while it is plugged into an electrical outlet!

Tool required: 5/16" hex key wrench

THE BELT TENSIONING BOLTS

The Life Fitness treadmill has access holes in the rear roller guards, which allow access to the tensioning bolts. These tensioning bolts make it possible to adjust tracking and centering of the striding belt (A) without removing the guards.

NOTE: It is extremely important that the treadmill be correctly leveled prior to any tracking adjustments. An unstable unit may cause striding belt misalignment. See "How To Stabilize the Life Fitness Treadmill" in the "Set Up" section prior to attempting any rear roller adjustments.

Before proceeding, it is helpful to visualize the REAR ROLLER (B) pivot point (C). Each adjustment made to one side of the ROLLER must be met with an equal and opposite adjustment (D) to the other side of the ROLLER to maintain an ideal belt tension at the pivot point.

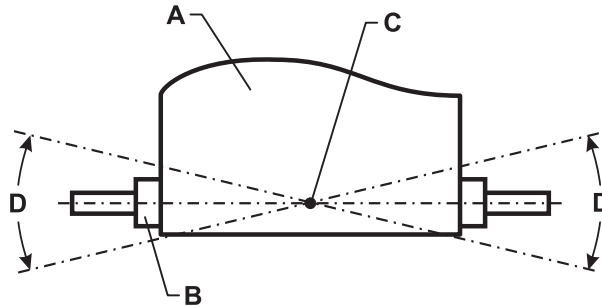

TRACKING (CENTERING) AN EXISTING OR NEW STRIDING BELT

- 1 Locate the two access holes to the belt tensioning bolts on each of the rear roller guards.
- 2 Stand on the sides of the treadmill and straddle the belt, not standing on it. Enter the MANUAL Workout and set the belt speed to run at 4.0 mph (6,4 kph).
- 3 If the striding belt has moved to the right, turn the right tension bolt 1/4 turn clockwise with provided ¼" Allen wrench, and then turn the left tension bolt 1/4 turn counter-clockwise to start striding belt tracking back to center of roller.
- 4 If the striding belt has moved to the left, turn the left tension bolt 1/4 turn clockwise and then turn the right tension bolt 1/4 turn counter-clockwise to start striding belt tracking back to center of roller. Repeat adjustments until striding belt appears centered. Allow machine to continue running for several minutes to observe if tracking remains stabilized.

NOTE: Do not exceed one full turn of the adjusting screws in either direction. If after one full turn the belt does not track properly, contact Customer Support Services. The phone numbers are listed in "How to Obtain Product Service."

TENSIONING AN EXISTING STRIDING BELT

Under normal usage, the treadmill striding belt may stretch slightly. If the belt starts to slip during use, take the steps listed below to correct the tension.

- 1 Using the STOP key, stop the treadmill.
- 2 Turn the belt tensioning bolts clockwise a quarter-turn per side to tension the belt. Do not exceed one full turn (four quarter-turns per side).
- 3 Set the treadmill at 2.0-mph (3,2 kph) and check proper tracking. If the striding belt drifts to the left or right see Tracking (Centering) an Existing or New Striding Belt on the preceding page.

NOTE: Do not over-tighten the tensioning bolts while making belt adjustments. Over-tightening of bolts may over stretch and damage the striding belt or roller bearings. Do not exceed one full turn of either bolt in either direction.

6.4 HOW TO OBTAIN PRODUCT SERVICE

1. Verify the symptom and review the operating instructions. The problem may be unfamiliarity with the product and its features and workouts.
2. Locate and document the serial number of the unit, which is located on the serial number plate above the power entry area.
3. Contact the nearest Life Fitness Customer Support Services Group:

For Product Service
Internationally:

Life Fitness Europe GmbH

Telephone: (+49) 089.317.751.66

FAX: (+49) 089.317.751.38

Life Fitness (UK) LTD

Telephone: (+44) 1353.665507

FAX: (+44) 1353.666018

Life Fitness Atlantic BV

Life Fitness Benelux

Telephone: +31 (0) 180 64 66 66

FAX: +31 (0) 180 64 66 99

Life Fitness Italia S.R.L.

Telephone: (+39) 0472.835.470

FAX: (+39) 0472.833.150

Toll-free telephone: 800.438836

Life Fitness Vertriebs GmbH

Telephone: (+43) 1615.7198

FAX: (+43) 1615.7198.20

Life Fitness Asia Pacific Ltd

Telephone: (+852) 2891.6677

FAX: (+852) 2575.6001

*Life Fitness Latin America
and Caribbean*

Telephone: (+1) 847.288.3964

FAX: (+1) 847 288.3886

Life Fitness Brazil

Telephone: (+55) 11.7295.2217

FAX: (+55) 11.7295.2218

Life Fitness Japan

Telephone: (+81) 3.3359.4306

FAX: (+81) 3.3359.4307

Life Fitness Iberia

Telephone : (+34) 93 672 4660

FAX : (+34) 93 672 4670

7 SPECIFICATIONS

7.1 LIFE FITNESS T3-0 TREADMILL SPECIFICATIONS

Designed use:	Consumer
Maximum user weight:	400 pounds / 180 kilograms
Speed range:	0.5 - 12.0 mph (0,8 - 20 kph) in 0.1 increments
Elevation range:	0%-15% (in 0.5% increments)
Motor:	3 HP continuous duty DC
Lift Motor:	Maximum duty cycle of operation is 1 minute on, 5 minutes off
Rollers:	2.0" precision crowned
Belt:	58" Length x 20" Width (147 cm Length x 51 cm Width), multi-ply
Deck:	Commercial grade, cushioned, not reversible
Handrails:	Ergo Crossbar with side handrails 1.15"
Workouts:	Fat Burn, Cardio, Heart Rate Hill, Heart Rate Interval, Extreme HR, Sport Training, 5K (and 10K) Sport Training, Hill, Random, Manual, EZ Incline, and 7 My Workout slots
Levels:	20 levels each: in Sport Training, 5K (and 10K) Sport Training, Hill, Random, and EZ Incline Workouts
Telemetry HR monitoring:	Standard (Polar HR monitoring system)
Accessory tray:	Standard- designed into system

Console style: Deluxe
Profile window: 7x15
Display: 16 character red LED Message Center
Warranty: 10 years motor, 5 years parts, 1 year labor, and lifetime on frame and life springs

Physical Dimensions:

Length: 76 inches / 194 centimeters
Width: 32.25 inches / 82 centimeters
Height: 55.5 inches / 141 centimeters
Weight: 253 pounds / 115 kilograms

Shipping Dimensions:

Carton
Length: 84.0 inches / 213 centimeters
Width: 34.0 inches / 86.4 centimeters
Height: 18.5 inches / 47.0 centimeters
Weight: 277 pounds / 125,9 kilograms

7.2 LIFE FITNESS T3-5 TREADMILL SPECIFICATIONS

Designed use:	Consumer
Maximum user weight:	400 pounds / 180 kilograms
Speed range:	0.5 - 12.0 mph (0,8 - 20 kph) in 0.1 increments
Elevation range:	0%-15% (in 0.5% increments)
Motor:	3 HP continuous duty DC
Lift Motor:	Maximum duty cycle of operation is 1 minute on, 5 minutes off
Rollers:	2.5" precision crowned
Belt:	60" Length x 20" Width (152 cm Length x 51 cm Width), multi-ply
Deck:	Commercial grade, cushioned, not reversible
Handrails:	Ergo Crossbar with side handrails 1.15"
Workouts:	Fat Burn, Cardio, Heart Rate Hill, Heart Rate Interval, Extreme HR, Sport Training, 5K (and 10K) Sport Training, Hill, Random, Manual, 30-Minute Walk, 3-Mile Jog, 45-Minute Cross-Train, EZ Incline, 7 My Workout slots, and 1 Custom Workout slot
Levels:	20 levels each: in Sport Training, 5K (and 10K) Sport Training, Hill, Random, and EZ Incline Workouts
Telemetry HR monitoring:	Standard (Polar HR monitoring system)
Accessory tray:	Standard- designed into system
Console style:	Deluxe

Profile window: 7x15
Display: 16 character red LED Message Center
Warranty: 10 years motor, 5 years parts, 1 year labor, and lifetime on frame and life springs

Physical Dimensions:

Length: 78.5 inches / 199 centimeters
Width: 33 inches / 84 centimeters
Height: 55.5 inches / 141 centimeters
Weight: 270 pounds / 122 kilograms

Shipping Dimensions:

Carton
Length: 84.0 inches / 213 centimeters
Width: 34.0 inches / 86.4 centimeters
Height: 18.5 inches / 47.0 centimeters
Weight: 308 pounds / 139,7 kilograms

8 WARRANTY INFORMATION

WHAT IS COVERED:

This Life Fitness consumer product ("Product") is warranted to be free of all defects in material and workmanship.

WHO IS COVERED:

The original purchaser or any person receiving a newly purchased Product as a gift from the original purchaser.

HOW LONG IS IT COVERED:

Residential: All electrical and mechanical components and labor are covered, after the date of purchase, as listed on the chart below.

Non-Residential: Warranty void (this Product is intended for residential use only).

WHO PAYS SHIPPING & INSURANCE FOR SERVICE:

If the Product or any warranted part must be returned to a service facility for repairs, Life Fitness will pay all shipping and insurance charges during the warranty period (within the United States only). The purchaser is responsible for shipping and insurance charges after the warranty has expired.

WHAT WE WILL DO TO CORRECT COVERED DEFECTS:

We will ship to you any new or rebuilt replacement part or component, or, at our option, replace the Product. Such replacement parts are warranted for the remaining portion of the original warranty period.

WHAT IS NOT COVERED:

Any failures or damage caused by unauthorized service, misuse, accident, negligence, improper assembly or installation, debris resulting from any construction activities in the Product's environment, rust or corrosion as a result of the Product's location, alterations or modifications without our written authorization or by failure on your part to use, operate and maintain the Product as set out in your User Manual ("Manual"). All terms of this warranty are void if this Product is moved beyond the continental borders of the United States of America (excluding Alaska, Hawaii and Canada) and are then subject to the terms provided by that country's local authorized Life Fitness Representative.

WHAT YOU MUST DO:

Retain proof of purchase (our receipt of the attached registration card assures registration of purchase information but is not required); use, operate and maintain the Product as specified in the Manual; notify Customer Service of any defect within 10 days after discovery of the defect; if instructed, return any defective part for replacement or, if necessary, the entire Product for repair. Life Fitness reserves the right to decide whether or not a product is to be returned for repair.

USER MANUAL:

It is VERY IMPORTANT THAT YOU READ THE MANUAL before operating the Product. Remember to perform the periodic maintenance requirements specified in the Manual to assure proper operation and your continued satisfaction.

PRODUCT REGISTRATION:

Register online at www.lifefitness.com/registration. Our receipt assures that your name, address and date of purchase are on file as a registered owner of the Product. Failure to return the card will not affect your rights under this warranty. Being a registered owner assures coverage in the event you lose your proof of purchase. Please retain your proof of purchase, such as your bill of sale or receipt.

HOW TO GET PARTS & SERVICE:

Simply call Customer Service at 1-800-351-3737 or (+1) 847-288-3300, Monday through Friday from 8:00 a.m. to 5:00 p.m. Central Standard Time, and tell them your name, address and the serial number of your Product (consoles and frames may have separate serial numbers). They will tell you how to get a replacement part, or, if necessary, arrange for service where your Product is located.

EXCLUSIVE WARRANTY:

THIS LIMITED WARRANTY IS IN LIEU OF ALL OTHER WARRANTIES OF ANY KIND EITHER EXPRESSED OR IMPLIED, INCLUDING BUT NOT LIMITED TO THE IMPLIED WARRANTIES OF MERCHANTABILITY AND FITNESS FOR A PARTICULAR PURPOSE, AND ALL OTHER OBLIGATIONS OR LIABILITIES ON OUR PART. We neither assume nor authorize any person to assure for us any other obligation or liability concerning the sale of this Product. Under no circumstances shall we be liable under this warranty, or otherwise, of any damage to any person or property, including any lost profits or lost savings, for any special, indirect, secondary, incidental or consequential damages of any nature arising out of the use of or inability to use this Product. Some states do not allow the exclusion or limitation of implied warranties or of liability for incidental or consequential damages, so the above limitations or exclusions may not apply to you. Warranties may vary outside the U.S. Contact Life Fitness for details.

CHANGES IN WARRANTY NOT AUTHORIZED:

No one is authorized to change, modify or extend the terms of this limited warranty.

EFFECT OF U.S. STATE LAWS:

This warranty gives you specific legal rights and you may have other rights which vary from state to state.

MODEL	LIFETIME	10 YEARS	5 YEARS	1 YEAR
T30	Frame & Lifesprings	Motor	Electrical Parts & Mechanical Parts	Labor
T35	Frame & Lifesprings	Motor	Electrical Parts & Mechanical Parts	Labor



Life Fitness offers a full line of premier fitness equipment for the home.

TOTAL-BODY ELLIPTICAL CROSS-TRAINERS | TREADMILLS | LIFECYCLE® EXERCISE BIKES
STAIRCLIMBERS | GYM SYSTEMS

5100 N. RIVER ROAD, SCHILLER PARK, ILLINOIS 60176
LIFEFITNESS.COM