

# Symbio™ Console

Symbio Incline Elliptical, Symbio Recumbent Cycle, Symbio Runner, Symbio Upright LifeCycle®, and Symbio Upright SwitchCycle

Owner's Manual





# Corporate Headquarters

Columbia Centre III, 9525 Bryn Mawr Avenue, Rosemont, IL 60018 • U.S.A.  
847.288.3300 • FAX: 847.288.3703  
Service phone number: 800.351.3737 (toll-free within U.S.A., Canada)  
Global Website: [www.lifefitness.com](http://www.lifefitness.com)

## International Offices

### AMERICAS

#### North America

##### Life Fitness, LLC

Columbia Centre III  
9525 Bryn Mawr Avenue  
Rosemont, IL 60018 U.S.A.  
Telephone: (847) 288 3300  
Service Email:  
[customersupport@lifefitness.com](mailto:customersupport@lifefitness.com)  
Sales/Marketing Email:  
[commercialsales@lifefitness.com](mailto:commercialsales@lifefitness.com)

#### Brazil

##### Life Fitness Brasil

Av. Rebouças, 2315  
Pinheiros  
São Paulo, SP 05401-300  
BRAZIL  
SAC: 0800 773 8282 option 2  
Telephone: +55 (11) 3095 5200 option 2  
Service Email: [suportebr@lifefitness.com](mailto:suportebr@lifefitness.com)  
Sales/Marketing Email:  
[vendasbr@lifefitness.com](mailto:vendasbr@lifefitness.com)

#### Latin America and Caribbean\*

##### Life Fitness, LLC

Columbia Centre III  
9525 Bryn Mawr Avenue  
Rosemont, IL 60018 U.S.A.  
Telephone: (847) 288 3300  
Service Email:  
[customersupport@lifefitness.com](mailto:customersupport@lifefitness.com)  
Sales/Marketing Email:  
[commercialsales@lifefitness.com](mailto:commercialsales@lifefitness.com)

### EUROPE, MIDDLE EAST, and AFRICA (EMEA)

#### Belgium, Netherlands, and Luxemburg

##### Life Fitness Atlantic BV

Bijdorpplein 25-31  
2992 LB Barendrecht  
THE NETHERLANDS  
+3118064666  
Service Email:  
[service.benelux@lifefitness.com](mailto:service.benelux@lifefitness.com)  
Sales/Marketing Email:  
[marketing.benelux@lifefitness.com](mailto:marketing.benelux@lifefitness.com)

#### United Kingdom

##### Life Fitness UK LTD

Unit 109<sup>a</sup>  
Lancaster Way Business Park  
Ely, Cambs, CB6 3NX  
Telephone: General Office (+44)  
1353.666017  
Customer Support (+44) 1353.665507  
Service Email: [uk.support@lifefitness.com](mailto:uk.support@lifefitness.com)  
Sales/Marketing Email: [life@lifefitness.com](mailto:life@lifefitness.com)

#### Germany, Austria, and Switzerland

##### Life Fitness Europe GMBH

Neuhofweg 9  
85716 Unterschleißheim  
GERMANY  
Telephone:  
+49 (0) 89 / 31775166 Germany  
+43 (0) 1 / 6157198 Austria  
+41 (0) 848 / 000901 Switzerland  
Service Email:  
[kundendienst@lifefitness.com](mailto:kundendienst@lifefitness.com)  
Sales/Marketing Email:  
[vertrieb@lifefitness.com](mailto:vertrieb@lifefitness.com)

#### Spain

##### Life Fitness IBERIA

C/Frederic Mompou 5,1<sup>a</sup><sup>a</sup>  
08960 Sant Just Desvern Barcelona  
SPAIN  
Telephone: (+34) 93.672.4660  
Service Email:  
[servicio.tecnico@lifefitness.com](mailto:servicio.tecnico@lifefitness.com)  
Sales/Marketing Email:  
[info.iberia@lifefitness.com](mailto:info.iberia@lifefitness.com)

### All Other EMEA Countries and Distributor Business EMEA\*

##### Life Fitness Atlantic BV

Bijdorpplein 25-31  
2992 LB Barendrecht  
THE NETHERLANDS  
+3118064666  
Service Email:  
[emeaservicesupport@lifefitness.com](mailto:emeaservicesupport@lifefitness.com)

### ASIA PACIFIC (AP)

#### Japan

##### Life Fitness Japan, Ltd

4-17-33 Minami Aoyama 1F/B1F  
Minato-ku - Tokyo 107-0062  
Japan  
Telephone: (+81) 0120.114.482  
Fax: (+81) 03-5770-5059  
Service Email: [service.lfj@lifefitness.com](mailto:service.lfj@lifefitness.com)  
Sales/Marketing Email:  
[sales@lifefitnessjapan.com](mailto:sales@lifefitnessjapan.com)

#### Hong Kong

##### Life Fitness Asia Pacific LTD

26/F, Global Trade Square  
21 Wong Chuk Hang Road  
Wong Chuk Hang  
Hong Kong  
Telephone: (+852) 25756262  
Fax: (+852) 25756894  
Service Email: [service.hk@lifefitness.com](mailto:service.hk@lifefitness.com)  
Sales/Marketing Email:  
[marketing.hk.asia@lifefitness.com](mailto:marketing.hk.asia@lifefitness.com)

### All Other Asia Pacific countries and distributor business Asia Pacific\*

##### Life Fitness Asia Pacific LTD

26/F, Global Trade Square  
21 Wong Chuk Hang Road  
Wong Chuk Hang  
Hong Kong  
Telephone: (+852) 25756262  
Fax: (+852) 25756894  
Service Email: [service.ap@lifefitness.com](mailto:service.ap@lifefitness.com)  
Sales/Marketing Email:  
[marketing.hk.asia@lifefitness.com](mailto:marketing.hk.asia@lifefitness.com)

\*Also check [www.lifefitness.com](http://www.lifefitness.com) for local representation or distributor/dealer

## User and Service Documents Link

---

<https://fn.fit/KnowledgeBase>

<https://fn.fit/SupportDocuments>

Additional information is available online using the links above.

تتوفر معلومات إضافية على الإنترنت باستخدام الرابط أعلاه.

点击上面的链接可在线获取更多信息。

Flere oplysninger er tilgængelige online gennem linket ovenfor.

Bijkomende informatie is online beschikbaar via bovenstaande link.

Vous trouverez plus d'informations en ligne à l'aide du lien ci-dessus.

Zusätzliche Informationen finden Sie online über den oben angegebenen Link.

Ulteriori informazioni sono disponibili online utilizzando il link sopra riportato.

追加情報は上記リンクを使用してオンラインで利用可能です。

상기 링크를 통해 온라인에서 추가 정보를 볼 수 있습니다.

Informações adicionais estão disponíveis on-line, através do link acima.

Дополнительная информация доступна в интернете по ссылке, указанной выше.

Mediante el enlace anterior podrá acceder a información adicional en línea.

Ytterligare information finns online genom att använda länken ovan.

İnternet üzerinden daha fazla bilgi edinmek için yukarıdaki bağlantıyı kullanabilirsiniz.

هناك معلومات إضافية متاحة على الإنترنت باستخدام الرابط أعلاه.

Informazio osagarria eskuragarri dago goiko estekaren bidez.

Допълнителна информация можете да намерите онлайн, като използвате връзката по-горе.

Mitjançant l'enllaç anterior podreu accedir a informació addicional en línia.

使用上面的連結線上提供額外資訊。

Dodatne informacije možete pronaći na internetu sljedeći vezu iznad.

ከላይ የተመጠውን አገናኝ(ሊንክ) በመጠቀም መረጃዎች አንላይን ያገኛሉ።

Lisätietoja on saatavissa verkosta käyttämällä yllä olevaa linkkiä.

Wubetumi anya nsem afoforo aka ho wa websait so denam asem a ewa atifi ho a wubemia so so.

Πρόσθετες πληροφορίες είναι διαθέσιμες online χρησιμοποιώντας το σύνδεσμο παραπάνω.

מידע נוסף אפשר לקבל באינטרנט באמצעות הקישור לעיל.

További információ elérhető online, a fenti hivatkozás segítségével.

Viðbótarupplýsingar eru fáanlegar á netinu með því að smella á tengilinn hér fyrir ofan.

Plus indicium per superum situm potes invenire.

മുകളിലുള്ള ലിങ്ക് ഉപയോഗിച്ച് ഓൺലൈനിൽ കൂടുതൽ വിവരങ്ങൾ ലഭ്യമാണ്.

Ytterligere informasjon er tilgjengelig på nettet via linken ovenfor.

Dodatkowe informacje są dostępne online pod powyższym odnośnikiem.

Informações adicionais estão disponíveis online a usar o link acima.

Informații suplimentare sunt disponibile online, utilizând link-ul de mai sus.

Dodatne informacije dostupne su na mreži putem gornjeg linka.

Ďalšie informácie sú dostupné online na vyššie uvedenom odkaze.

# Table of Contents

<b>Safety</b>		
Safety Instructions.....	4	
Consignes de Sécurité.....	8	
Before Use.....	11	
Functional Information.....	11	
Immobilization Method - Treadmill Only.....	13	
<b>Getting Connected</b>		
Internet Requirements.....	15	
Wireless LAN Requirements.....	15	
Network Equipment Placement and Power Requirements.....	15	
Port Configuration.....	15	
Destination URLs.....	15	
<b>Getting Started</b>		
Console Features.....	16	
Auxiliary Controls.....	17	
Device Connection.....	21	
Qi® Wireless Induction Charger.....	25	
The Lifepulse™ System.....	27	
How To Adjust Smart Lighting.....	28	
<b>Operation</b>		
Home Screen.....	30	
In-Workout Views and Entertainment Choices.....	35	
Pause Workout.....	42	
Cool Down.....	43	
Hybrid Mode.....	44	
<b>Workouts</b>		
Workouts List.....	45	
Workout Descriptions.....	46	
Workout Setup - Data Inputs.....	48	
Quick Start.....	58	
LFOD+™.....	59	
Standard Goals.....	65	
Fit Tests.....	66	
<b>Maintenance and Troubleshooting</b>		
Approved and Compatible Cleaners.....	69	
Troubleshooting.....	69	
<b>Manager's Configuration</b>		
Access Systems Options.....	74	
Default Settings.....	76	
TV.....	78	
<b>Specifications</b>		
Console Specifications.....	107	
Console Dimensions.....		108
<b>Copyrights and Trademarks</b>		
List of Copyrights and Trademarks.....		109
<b>Warranty</b>		
What is Covered.....		110
Who is Covered.....		110
How Long It is Covered.....		110
Who Pays Transportation and Insurance For Service.....		110
What We Will Do To Correct Covered Defects.....		110
What is Not Covered.....		110
What You Must Do.....		110
How to Get Parts and Service.....		110
Exclusive Warranty.....		110
Changes in Warranty Not Authorized.....		111
Effects of State Laws.....		111
Terms of Warranty Coverage.....		111

# 1. Safety

## Safety Instructions

 Read all instructions before use.

### ALL PRODUCTS

 **WARNING:** Health-related injuries may result from incorrect or excessive use of exercise equipment. Life Fitness STRONGLY recommends seeing a physician for a complete medical exam before undertaking an exercise program, particularly if the user has a family history of high blood pressure or heart disease, is over the age of 45, smokes, has high cholesterol, is obese, or has not exercised regularly in the past year. If, at any time while exercising, the user experiences faintness, dizziness, pain, or shortness of breath, he or she must stop immediately.

 **CAUTION:** Any changes or modifications to this equipment could void the product warranty.

 **WARNING:** Keep batteries out of reach of children.

Some chest straps may contain a removable battery.

- Swallowing may lead to serious injury in as little as 2 hours or death, due to chemical burns and potential perforation of the esophagus.
- If you suspect your child has swallowed a battery, immediately call your local poison control for fast, expert advice.
- Examine devices and make sure the battery compartment is correctly secured, e.g. that the screw or other mechanical fastener is tightened. Do not use if compartment is not secure.
- Dispose of used button batteries immediately and safely. Flat batteries can still be dangerous.
- Tell others about the risk associated with button batteries and how to keep their children safe.

 **WARNING:** To reduce the risk of burns, fire, electric shock, or injury, it is imperative to connect each product to a properly grounded electrical outlet.





 **WARNING:** Heart rate monitoring systems may be inaccurate. Over exercising may result in serious injury or death. If you feel faint, stop exercising immediately.

 **DANGER:** To reduce the risk of electrical shock or injury from moving parts, always unplug product before cleaning or attempting any maintenance activity.

- Life Fitness does not warrant nor guarantee that component parts used in the manufacture of products offered under the Life Fitness are latex-free. Users of these products must take all necessary precautions to prevent accidental contact that could lead to an adverse latex reaction.
- Never operate the product if it has a damaged power cord or electrical plug, or if it has been dropped, damaged, or even partially immersed in water. Contact Customer Support Services.
- Position the product so that the power cord plug to the wall is accessible to the user. Make sure that the power cord is not knotted or twisted and that it is not trapped under any equipment or other objects.
- If the electrical supply cord is damaged, it must be replaced by the manufacturer, an authorized service agent, or a similarly qualified person to avoid a hazard.
- Always follow the console instructions for proper operation.
- This appliance is not intended for use by persons (including children) with reduced physical, sensory, or mental capabilities, or lack of experience or knowledge unless they have supervision or been given instruction concerning the use of the appliance by a person responsible for their safety.
- This equipment is not intended for use by children. Keep children under the age of 14 away from the machine.
- Do not use this product outdoors, near swimming pools or in areas of high humidity.
- Never operate the product with the air openings blocked. Keep air openings free of lint, hair, or any other obstructing material.
- Never insert objects into any opening in these products. If an object should drop inside, turn off the power, unplug the power cord from the outlet, and carefully retrieve it. If the item cannot be reached, contact Customer Support Services.
- Never place liquids of any type directly on the unit, except in an accessory tray or holder. Containers with lids are recommended.
- Do not use these products in bare feet. Always wear shoes. Wear shoes with rubber or high-traction soles. Do not use shoes with heels, leather soles, cleats or spikes. Make sure no stones are embedded in the soles.
- Keep all loose clothing, shoelaces, and towels away from moving parts.
- Do not reach into, or underneath, the unit or tip it on its side during operation.
- Do not allow other people to interfere in any way with the user or equipment during a workout.



- Allow LCD consoles to “normalize” with respect to temperature for one hour before plugging the unit in and using.
- Use these products for their intended use as described in this manual. Do not use attachments that have not been recommended by the manufacturer.
- Free standing equipment shall be installed on a stable and leveled surface.
- Read all warnings on each product prior to starting a workout.
- If warnings are missing or damaged, please contact Customer Support Services immediately for replacement warning labels. Warning labels are shipped with every product and should be installed before product is used. Life Fitness is not responsible for missing or damaged warning labels.

## TREADMILL

-  **CAUTION:** Risk of injury to persons - to avoid injury, use extreme caution when stepping onto or off of a moving belt. Read assembly instruction manual before using.
-  **WARNING:** Keep the area 6.5 ft. (2 m) by 3 ft. (0.9 m) behind the treadmill clear of any obstructions, including walls, furniture, and other equipment. Contact Customer Support Services for an optional longer power cord if necessary.
-  **WARNING:** Be sure the emergency stop lanyard is clipped to the user and in proper position on the treadmill before beginning any workout.
-  **WARNING:** The belt centering adjustment must be performed if the belt is not between the marks indicating the maximum allowed lateral positions. Refer to Treadmill Assembly Instructions.
-  **WARNING:** This product can expose you to chemicals including Acrylonitrile, which is known to the State of California to cause cancer and birth defects or other reproductive harm. For more information go to <http://www.P65Warnings.ca.gov>



- When the product is not in use, Life Fitness recommends unplugging the product. Disconnect from the electrical outlet when not in use, and before putting on or taking off parts. To disconnect, turn power OFF at the ON/OFF switch, then remove plug from electrical outlet.
- Keep the power cord away from heated surfaces. Do not pull the equipment by the power cord or use the cord as a handle. Do not run the power cord on the floor under or along the side of the treadmill.
- Handrails may be held to enhance stability as needed, but are not for continuous use.
- Never mount or dismount the treadmill while the running belt is moving. Use the handrails whenever additional stability is required. In case of an emergency, such as tripping, grasp the handrails, and place the feet on the side platforms.
- Never walk or jog backwards on the treadmill.
- Do not use this product in areas where aerosol spray products are being used or where oxygen is being administered. Such substances create the danger of combustion and explosion.
- In conformity with the European Union Machinery Directive 2006/42/EC, this equipment unloaded runs at sound pressure levels below 70 dB (A) at the average operating speed of 12 km/hr (commercial units) and 8 km/hr (home units). Noise emission under load is higher than without load.

## LIFECYCLE® EXERCISE BIKES

-  **WARNING:** Allow a distance of 16 in. (41 cm) between the widest part of the bike and other objects on either side. Provide at least 3 ft. (0.9 m) between the front or rear of the bike to any other objects and 2 ft. (0.6 m) in the direction the equipment is accessed from.
-  **WARNING:** This product can expose you to chemicals including Acrylonitrile, which is known to the State of California to cause cancer and birth defects or other reproductive harm. For more information go to <http://www.P65Warnings.ca.gov>

- Do not stand or sit on plastic shrouds.
- Use caution when mounting or dismounting the bike. Use the stationary handlebar whenever additional stability is required.

## CROSS-TRAINER

-  **WARNING:** Ensure that there is at least 1 ft. (0.3 m) of clearance in front of the Cross-Trainer and at least 2 ft. (0.6m) on the side.
-  **WARNING:** The Cross-Trainer is not equipped with a free-wheeling feature. Therefore, the product cannot be stopped immediately.
-  **WARNING:** This product can expose you to chemicals including Acrylonitrile, which is known to the State of California to cause cancer and birth defects or other reproductive harm. For more information go to <http://www.P65Warnings.ca.gov>

- Do not stand or sit on the rear plastic covers of the Cross-Trainer.
- Do not stand on center tube of the Cross-Trainer.

- The individual human power required to perform an exercise may be different than the mechanical power displayed on the Cross-Trainer.
- Use caution when mounting or dismounting the Cross-Trainer. Before mounting, use the moving arms to bring the pedal nearest to you to the lowest position. Use the stationary handlebars whenever additional stability is required. While exercising, hold onto the moving arms.
- Never face backward while using the Cross-Trainer.

**SAVE THESE INSTRUCTIONS FOR FUTURE REFERENCE.**

## ANATEL Compliance Information - Brazil

This equipment incorporates the products approved by ANATEL under the following numbers:

MODULE	ANATEL NUMBER
WIFI / BLUETOOTH	08437-23-09600
WIRELESS CHARGER	01535-21-13620
RFID	18033-20-07558
NFC	13389-21-14239
ANT+	00127819

This equipment is not entitled to protection against harmful interference and may not cause interference in duly authorized systems.

## Consignes de Sécurité

 Veuillez lire toutes les instructions avant usage.

### TOUS LES APPAREILS

 **AVERTISSEMENT :** Des problèmes de santé peuvent survenir en cas d'une utilisation incorrecte ou excessive de l'équipement. Life Fitness Recommande VIVEMENT aux utilisateurs de passer un examen médical complet avant d'entamer un programme d'entraînement, et tout particulièrement dans les cas suivants : antécédents familiaux d'hypertension (pression sanguine trop élevée) ou de pathologies cardiaques, utilisateurs de 45 ans ou plus, tabagisme, hypercholestérolémie (taux de cholestérol sanguin trop élevé), obésité, absence d'exercice physique depuis un an ou plus. Si, pendant l'usage de l'appareil, l'utilisateur éprouve un malaise, des vertiges, des douleurs ou des difficultés à respirer, il doit s'arrêter immédiatement.

 **ATTENTION :** Toute modification apportée à cet équipement pourrait en annuler la garantie.

 **AVERTISSEMENT :** Tenir les piles hors de portée des enfants.

Certaines sangles de poitrine peuvent contenir une pile jetable.

- L'ingestion de la pile peut provoquer des blessures graves voire la mort en moins de 2 heures en raison du risque de brûlures chimiques et de perforation de l'œsophage.
- Si vous pensez que votre enfant a avalé une pile, contactez immédiatement le centre anti-poison local pour obtenir des conseils spécifiques.
- Contrôlez l'appareil et assurez-vous que le compartiment pour pile est bien fermé, par exemple que la vis ou toute autre fixation mécanique est bien serrée. Ne pas utiliser le produit si le compartiment n'est pas bien fermé.
- Éliminer les piles bouton immédiatement et de manière sûre. Les piles bouton sont une source de danger.
- Informez les tiers des risques associés aux piles bouton et de la manière dont ils doivent agir pour protéger leurs enfants.

 **AVERTISSEMENT :** Pour réduire les risques de brûlures, d'incendies, de décharges électriques ou de blessures, il est essentiel de brancher chaque appareil sur une prise électrique correctement mise à la terre.





 **AVERTISSEMENT :** Les systèmes de surveillance de la fréquence cardiaque peuvent être inexacts. Un exercice trop intensif peut entraîner des blessures graves, voire mortelles. En cas de malaise, interrompez immédiatement la séance d'entraînement.

 **DANGER :** Pour réduire les risques de chocs électriques ou de blessures en raison des pièces mobiles, débranchez toujours les produits avant de les nettoyer ou de procéder aux tâches d'entretien.

- Life Fitness ne garantit pas que les composants utilisés dans la fabrication des produits proposés dans la Life Fitness sont exempts de latex. Les utilisateurs de ces produits doivent prendre toutes les précautions nécessaires pour éviter un contact accidentel qui pourrait entraîner une réaction indésirable au latex.
- Ne faites jamais fonctionner le produit dont la fiche ou le cordon d'alimentation sont altérés ni aucun appareil qui serait tombé, aurait été endommagé ou même partiellement plongé dans l'eau. Contactez le service à la clientèle.
- Placez l'appareil de façon à ce que l'utilisateur ait accès à la fiche du cordon d'alimentation. Assurez-vous que le cordon d'alimentation n'est pas noué ou tordu et qu'il n'est pas coincé sous un autre appareil ou sous tout autre objet.
- Si le cordon d'alimentation électrique est endommagé, il doit être remplacé par le fabricant, par un réparateur agréé ou par une personne qualifiée afin d'éviter tout danger.
- Pour un fonctionnement correct, suivez toujours les instructions de la console.
- Cet appareil n'est pas destiné à être utilisé par des personnes ou des enfants présentant des capacités physiques, sensorielles ou mentales réduites, ou un manque d'expérience et de connaissances, sauf en cas de supervision ou d'instructions relatives à son utilisation par une personne responsable de leur sécurité.
- Cet équipement n'est pas destiné à être utilisé par les enfants. Tenez les enfants âgés de moins de 14 ans à l'écart de la machine.
- N'utilisez pas ce produit à l'extérieur, près d'une piscine ou dans des endroits très humides.
- N'utilisez jamais le produit avec les ouvertures d'air bloquées. Maintenez les bouches d'aération exemptes de peluches, de cheveux ou de toute autre obstruction.
- N'introduisez jamais d'objet dans les ouvertures de cet appareil. Si un objet tombe dans l'appareil, mettez ce dernier hors tension, débranchez le cordon d'alimentation et récupérez l'objet avec précaution. Si vous ne pouvez pas l'atteindre, contactez le service d'assistance à la clientèle.
- Ne placez jamais de liquides d'aucune sorte directement sur l'appareil, sauf si vous disposez d'un support ou d'un plateau pour accessoires. Nous vous recommandons de n'utiliser que des récipients pourvus d'un couvercle.



- N'utilisez pas ces produits avec les pieds nus. Portez toujours des chaussures. Portez des chaussures à semelles en caoutchouc ou antidérapantes. N'utilisez pas de chaussures à talon, à semelle en cuir, à crampons ou à pointes. Assurez-vous qu'aucun caillou ne s'est incrusté dans les semelles.
- Éloignez les vêtements amples, les lacets de chaussure et les serviettes des parties mobiles de l'appareil.
- Ne placez pas les mains à l'intérieur ou sous l'appareil. Ne le faites pas basculer sur le côté durant son fonctionnement.
- Ne laissez aucune personne gêner l'utilisateur ou le fonctionnement de l'appareil pendant l'exercice.
- Laissez les consoles LCD s'adapter à la température ambiante pendant une heure avant de brancher l'appareil et de l'utiliser.
- Utilisez cet équipement uniquement aux fins auxquelles il est destiné et de la manière décrite dans le présent manuel. N'utilisez pas d'accessoires non recommandés par le fabricant.
- L'appareil utilisé de manière autonome doit être installé sur une surface stable et plane.
- Lisez les avertissements sur chaque produit avant de commencer à vous entraîner.
- Si certaines étiquettes d'avertissement sont manquantes ou endommagées, contactez immédiatement le service d'assistance à la clientèle. Nous vous en fournirons de nouvelles. Les étiquettes d'avertissement sont expédiées avec les appareils et doivent être installées avant utilisation de ces derniers. Life Fitness n'est pas responsable des étiquettes manquantes ou endommagées.

## TAPIS DE COURSE

-  **ATTENTION :** Risque de blessures - pour éviter toute blessure, faire preuve d'extrême prudence pour monter sur un tapis en mouvement, ou pour en descendre. Lisez les instructions d'assemblage avant toute utilisation.
-  **AVERTISSEMENT :** Laissez un espace de 2 m sur 90 cm (6,5 pieds sur 3 pieds) autour de la machine. Ne placez pas cette dernière près de murs, meubles ou autres équipements qui pourraient en obstruer l'accès. Contactez le service à la clientèle pour obtenir un cordon plus long au besoin.
-  **AVERTISSEMENT :** Avant de commencer tout exercice, il convient de s'assurer que le cordon de sécurité est bien fixé à l'utilisateur et correctement placé sur le tapis de course.
-  **AVERTISSEMENT :** La surface de course doit être recentrée si elle ne se situe pas entre les marques indiquant les positions latérales maximales autorisées. Consultez les instructions d'assemblage du tapis de course.
-  **AVERTISSEMENT :** This product can expose you to chemicals including Acrylonitrile, which is known to the State of California to cause cancer and birth defects or other reproductive harm. For more information go to <http://www.P65Warnings.ca.gov>

- Life Fitness recommande de débrancher le produit quand il n'est pas utilisé. Débranchez-le systématiquement après son utilisation et avant l'ajout et le retrait de pièces. Pour débrancher l'appareil, placez l'interrupteur de marche/arrêt sur ARRÊT et ôtez la prise électrique du mur.
- Maintenez le cordon d'alimentation à l'écart des surfaces chauffées. Ne tirez pas l'appareil par son cordon et n'utilisez pas celui-ci comme une poignée. Ne faites pas passer le cordon sur le sol, sous le tapis de course, ni le long de l'appareil.
- Les barres d'appui latérales peuvent servir à améliorer la stabilité, le cas échéant, mais elles ne sont pas conçues pour être utilisées de façon continue.
- Ne montez ni ne descendez jamais du tapis de course lorsque celui-ci est en mouvement. Le cas échéant, utilisez les barres latérales pour renforcer votre stabilité. En cas d'urgence, si vous trébuchez par exemple, saisissez les barres latérales et placez les pieds sur les plates-formes latérales.
- Ne reculez jamais sur le tapis, que ce soit en marchant ou en courant.
- N'utilisez pas l'appareil en présence d'aérosols ou en cas d'administration d'oxygène. Ces substances pourraient entraîner des risques d'incendie et d'explosion.
- Conformément à la directive Machines 2006/42/EC de l'Union européenne, à vide, cet équipement sans charge fonctionne à des niveaux de pression acoustique inférieurs à 70 dB(A) à une vitesse de fonctionnement moyenne de 12 km/h (gamme commerciale) et 8 km/h (gamme domestique). L'émission de bruit sous charge est plus élevée qu'à vide.

## VÉLOS D'APPARTEMENT LIFECYCLE®

-  **AVERTISSEMENT :** Laissez une distance de 41 cm (16 po) entre la partie la plus large du vélo et les objets se trouvant de part et d'autre. Laissez un dégagement d'au moins 90 cm (3 pieds) entre l'avant ou l'arrière du vélo et les objets alentour, et d'au moins 60 cm (2 pieds) dans la direction qui permet d'accéder à l'appareil.
-  **AVERTISSEMENT :** This product can expose you to chemicals including Acrylonitrile, which is known to the State of California to cause cancer and birth defects or other reproductive harm. For more information go to <http://www.P65Warnings.ca.gov>
- Ne vous mettez pas debout ni assis sur les caches en plastique.

- Montez et descendez avec précaution du vélo. Utilisez les poignées fixes lorsque vous avez besoin de renforcer votre équilibre.

## **CROSS-TRAINER**



**AVERTISSEMENT :** Veillez à laisser un dégagement d'au moins 30 cm (1 pied) devant le Cross-Trainer et d'au moins 60 cm (2 pieds) sur les côtés.



**AVERTISSEMENT :** Le Cross-Trainer n'est pas équipé d'une option roue libre. Par conséquent, il ne peut être arrêté instantanément.



**AVERTISSEMENT :** This product can expose you to chemicals including Acrylonitrile, which is known to the State of California to cause cancer and birth defects or other reproductive harm. For more information go to <http://www.P65Warnings.ca.gov>

- Ne vous mettez pas debout ni assis sur les caches en plastique situés à l'arrière du Cross-Trainer.
- Ne vous mettez pas debout sur le tube central du Cross-Trainer.
- La puissance nécessaire à chaque utilisateur pour effectuer un exercice peut différer de la puissance mécanique affichée sur le Cross-Trainer.
- Montez et descendez du Cross-Trainer avec la plus grande précaution. Avant de monter, placez la pédale située de votre côté en position basse, en vous aidant des bras mobiles. Utilisez les poignées fixes lorsque vous avez besoin de renforcer votre équilibre. Pendant les exercices, tenez les bras mobiles.
- Ne montez jamais à l'envers sur le Cross-Trainer.

**CONSERVEZ PRÉCIEUSEMENT CES INSTRUCTIONS POUR CONSULTATION ULTÉRIEURE.**

## Before Use

Before using this product, it is essential to read this ENTIRE operation manual and ALL assembly instructions. It describes equipment setup and instructs members on how to use it correctly and safely.

Avant d'utiliser ce produit, il est impératif de lire ce manuel d'utilisation en ENTIER, ainsi que TOUTES les instructions de montage. Ce manuel explique comment installer l'équipement, et comment l'utiliser correctement et sans danger.

Any service, other than cleaning or user maintenance, must be performed by an authorized service representative.



**CAUTION:** Any changes or modifications to this equipment could void the product warranty.



**CAUTION:** Toute modification apportée à cet équipement pourrait en annuler la garantie.

FCC Warning - Possible Radio / Television Interference

EN ISO 20957 Class SA (Bikes, Cross-Trainer): Professional and / or commercial use.

EN ISO 20957 Class SB (Treadmill only): Professional and / or commercial use.

### **EN ISO 20957 Class S: Professional and / or commercial use.**

**NOTE:** This equipment has been tested and found to comply with the limits for a Class A digital device, pursuant to part 15 of the FCC rules. These limits are designed to provide reasonable protection against harmful interference when the equipment is operated in a commercial environment. This equipment generates, uses and can radiate radio frequency energy, and if not installed and used in accordance with the instruction manual, may cause harmful interference to radio communications. Operation of this equipment in a residential area is likely to cause harmful interference in which case the user will be required to correct the interference at his own expense.

### **EN ISO 20957 Class H: Home use.**

EN ISO 20957 Class HA (Bikes, Cross-Trainer): Professional and / or commercial use. Upright SwitchCycle is for commercial use only.

EN ISO 20957 Class HB (Treadmill only): Professional and / or commercial use.

**NOTE:** This equipment has been tested and found to comply with the limits for a Class B digital device, pursuant to part 15 of the FCC rules. These limits are designed to provide reasonable protection against harmful interference in a residential installation. This equipment generates, uses and can radiate radio frequency energy, and if not installed and used in accordance with the user manual, may cause harmful interference to radio communications. However, there is no guarantee that the interference will not occur in a particular installation. If this equipment does cause harmful interference to radio or television reception, which can be determined by turning the equipment off and on, the user is encouraged to try to correct the interference by one or more of the following measures:

- Reorient or relocate the receiving antenna.
- Increase the separation between the equipment and the receiver.
- Connect the equipment into an outlet on a circuit different from that to which the receiver is connected.
- Consult the dealer or an experienced radio/TV technician for help.

### **Cross-Trainers only:**

#### **Cross-Trainers:**

For EN ISO 20957-9: 2016 Class SA accuracy testing, power at the crankshaft was measured by connecting the training equipment to a dynamometer. The crank was rotated and torque measured per EN ISO 20957-9: 2016 Class SA operating test conditions. Accuracy of the resulting watts displayed on the console and actual watts measured by dynamometer were found to be within the tolerance of EN ISO 20957-9: 2016 Class SA (+/- 5 Watts up to 50 Watts and +/- 10% over 50 Watts).

## Functional Information

This Owner's Manual describes the functions of the Symbio console with the following bases:

- Symbio™ Incline Elliptical
- Symbio™ Runner
- Symbio™ Recumbent Cycle
- Symbio™ Upright SwitchCycle
- Symbio™ Upright LifeCycle®

**Statements of Purpose:**

- The Symbio™ Runner treadmill is an exercise machine that enables users to walk or run, in place, indoors on a moving surface.
- The Symbio™ Incline Elliptical is an exercise machine that combines low-impact elliptical pedaling with push / pull arm motion to provide an efficient, effective total body workout indoors.
- The Symbio™ Recumbent Cycle, Symbio™ Upright SwitchCycle, and Symbio™ Upright LifeCycle® exercise bikes are machines that simulates the movements of riding a bicycle indoors at various speeds and levels of resistance.

## Immobilization Method - Treadmill Only

The purpose of immobilizing the unit is to prevent unauthorized use. The system causes immobilization of the unit when activated.

1. Tap the **LANGUAGE** icon on the **ATTRACT SCREEN** to access the **SELECT LANGUAGE** screen. (Language Icon position may vary on consoles.)

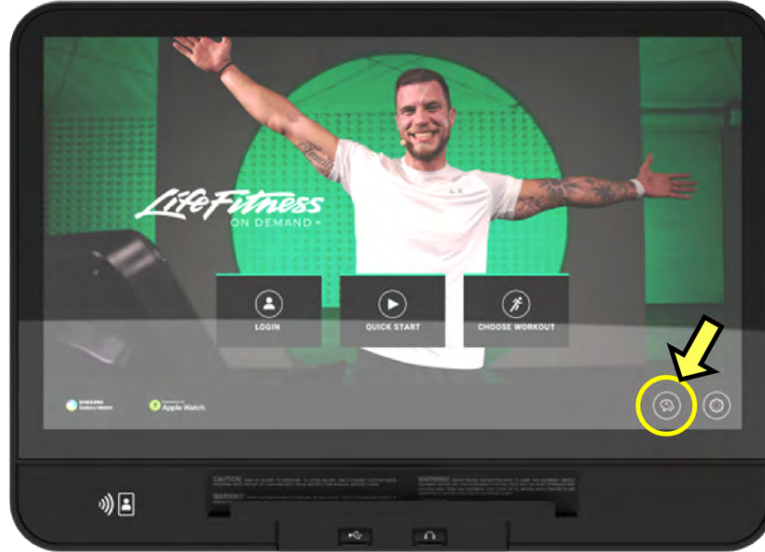

2. Tap the lower part of the **SELECT LANGUAGE** screen in the following sequence: **Lower-Left**, **Lower-Right**, **Lower-Left**, and **Lower-Right**.

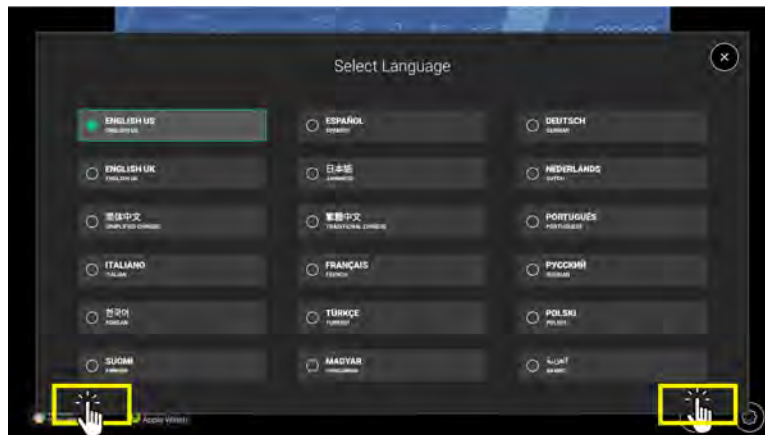

3. Tap the **Immobilize Unit** icon. **Enabled** will be displayed.



Item	Description
1	Immobilize Unit icon
2	Enabled icon
3	Exit icon

4. Tap the exit icon **X** to exit **System Options**.
5. Unit will reboot.

6. UNIT IMMOBILIZED BY MANAGER message appears on screen.

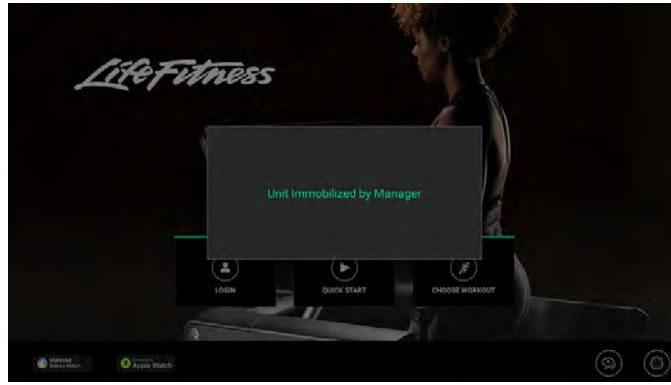

7. Tap the upper part of the **ATTRACT SCREEN** in the following sequence: **Upper-Left**, **Upper-Right**, **Upper-Left**, and **Upper-Right** to enter **SYSTEM OPTIONS**.

8. Tap the **Immobilize Unit** icon to disable.

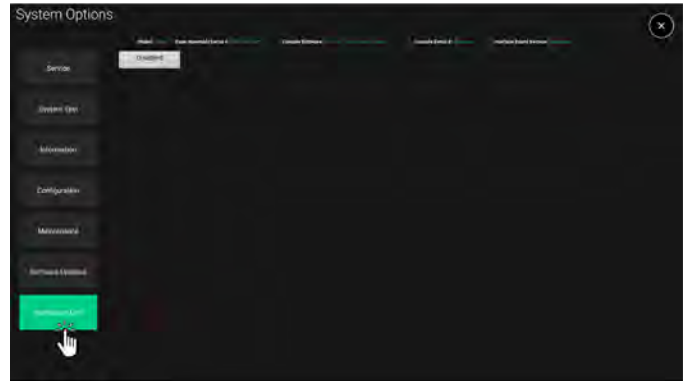

## 2. Getting Connected

### Internet Requirements

Minimum download bandwidth requirements for 1-8 units:

- 2.5 mbps
- +0.25 mbps for more each additional unit.

Minimum upload bandwidth requirement:

- 0.5 mbps

Wired Local Area Network (LAN) requirements:

You will need to provide the DHCP addresses for all of your units if your units are wired to the internet using an Ethernet cable. You will need a switch capable of aggregating the individual Ethernet cables.

1-7 units	8-23 units	24-47 units
8-port 10/100/1000	24-port 10/100/1000	48-port 10/100/1000

### Wireless LAN Requirements

**NOTE:** A dedicated internet connection is recommended. You will need to allow traffic outbound without any filtering or blocking on your internet connection.

#### Access Points

- Life Fitness recommends a maximum ratio of 15 products per wireless access point. Exceeding this ratio introduces the potential of dropped workouts and connection issues.
- The console requires a connection to a wireless network with SSID of LFwireless. If you purchase your access point from Life Fitness (ACCESS-POINT-01), the access point will by default have this SSID installed. Contact Life Fitness Customer Service at 1.800.351.3737 or your Life Fitness representative before setting up this network to receive the required password for this SSID.

#### Minimum requirements

- Commercial grade
- Band: Dual band 2.4 / 5 GHz
- Mounting: wall or ceiling mountable (e.g. Meraki MR32 or Rukus R500)
- Wireless-N Access Point (802.11n)
- Security: WPA2-PSK

Recommended Features: Wireless-AC Access Point (802.11ac)

#### Cabling Requirements

CAT 5e or CAT 6 cabling can be used to connect your wireless access points to your wired network. Life Fitness recommends using CAT 6 cable for this purpose.

### Network Equipment Placement and Power Requirements

Network equipment such as modems, wired routers and switches will require power; refer to product specs for exact requirements. Each access point will need power via PoE (Power over Ethernet) or additional optional power adapter. Refer to recommended manufacturer power requirements for further information.

### Port Configuration

All traffic initiated from our consoles is outbound (i.e. data only flows out from our consoles). If you do not block outbound traffic and the associated return traffic, then no additional configuration is needed. Otherwise, if your network restricts outbound traffic, you need to open outbound connections on these specific ports:

- TCP/UDP port 80
- TCP/UDP port 443
- TCP/UDP port 1883
- TCP/UDP 8883
- UDP port 1194

### Destination URLs

The cardio machines will contact \*.halo.fitness.com, \*.lflconnect.com, and \*.s3.amazonaws.com.

# 3. Getting Started

## Console Features

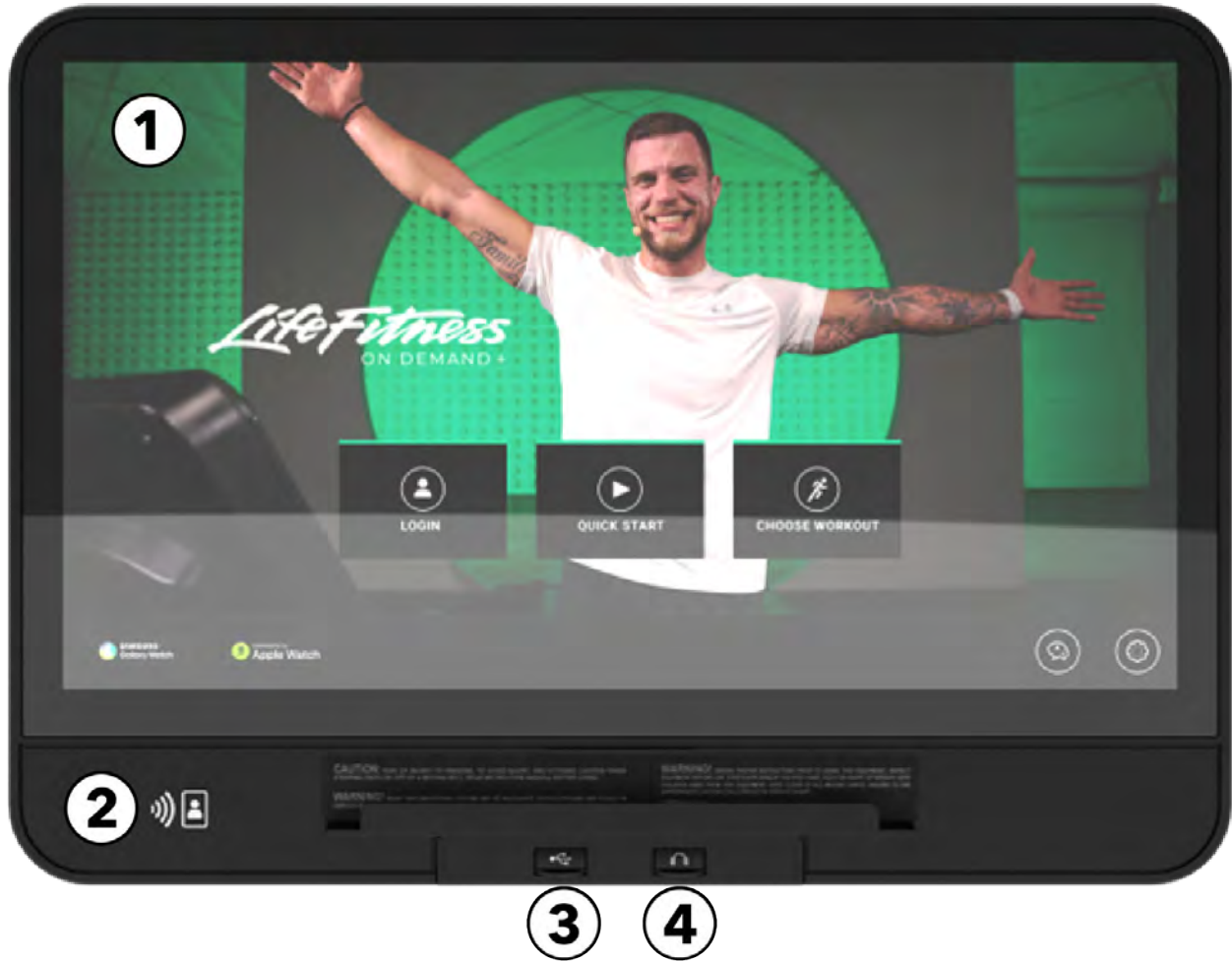

### 1. Touch Screen Display

- Use to select, set up, monitor and save workouts.
- Access entertainment options.

### 2. NFC (Near Field Communication) / Optional RFID (Radio Frequency Identification) :

- **NFC:** Connect to NFC enabled mobile devices, Apple Watch and Samsung Galaxy Watch for seamless pairing and data share.
- **RFID:** Fitness facility owners can order this option for their users allowing them to swipe their facility identification card on the console. The console's hardware is compatible with the two main frequencies (125kHz and 13.56Mhz) used for RFID cards. The RFID module also supports everything included within the NFC module.

### 3. USB: Charge USB devices and use for console software updates.

### 4. Headphones: Plug in headphones to listen to TV and entertainment options.

## Auxiliary Controls

### Symbio Incline Elliptical

The left handle controls incline. The right handle controls resistance.

Left Handle, Incline



Right Handle, Resistance

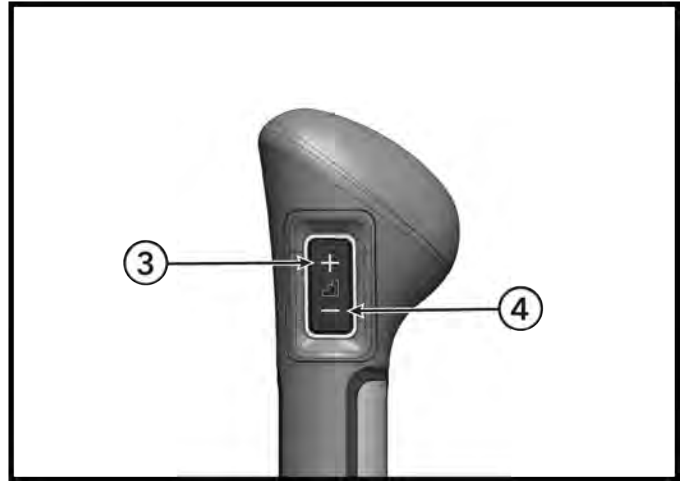

Item	Description	Qty.
1	Incline Up	1
2	Incline Down	1
3	Resistance Up	1
4	Resistance Down	1

The activity zone has three default incline levels and three default resistance levels.

### Activity Zone

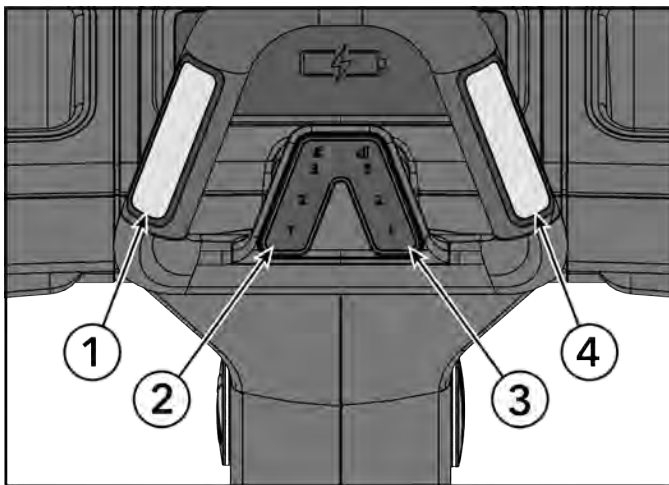

Item	Description	Qty.
1	Left Heart Rate Grip	1
2	Incline Level Quick Keys, 1, 2, 3	1
3	Resistance Levels Quick Keys, 1, 2, 3	1
4	Right Heart Rate Grip	1

To program quick keys, select desired incline or resistance level. Once achieved, press and hold quick key for 3 seconds to program the quick key. Process can be repeated for remaining quick keys if desired.

**NOTE:** When one of the Activity Zone buttons are pressed, the backlight for that specific button will light indicating which quick-select level was activated. The backlight for these buttons will remain off until selected by the user, or the resistance level matching the pre-selected levels.

## Symbio Runner

The Control Pad allows users to adjust incline, Adaptive Flex Deck® settings, and speed.

It also includes the E-Stop button. Press once during a workout to pause the workout. Pulling the lanyard will end workout.

### Control Pad

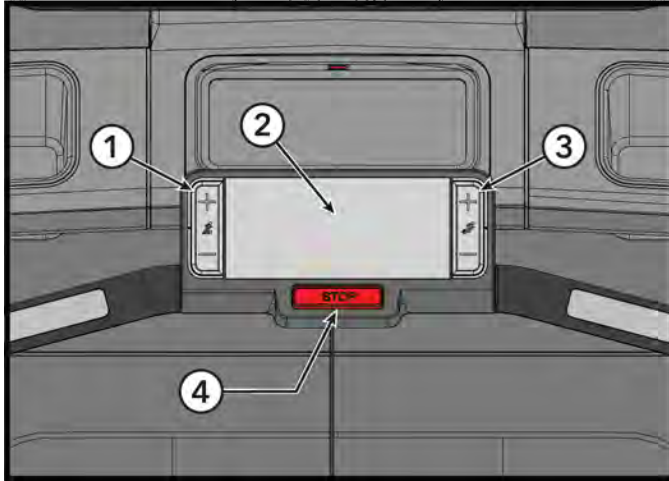

Item	Description	Qty.
1	Incline Up, Incline Down	1
2	Center Console	1
3	Speed Up, Speed Down	1
4	E-Stop Button	1

### Incline settings in control pad

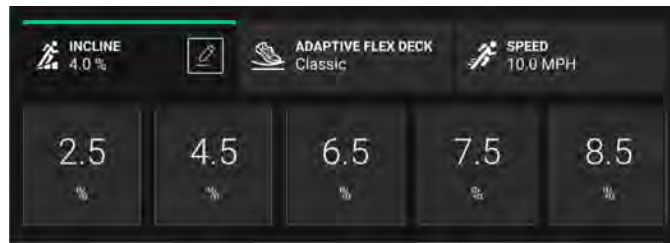

### Adaptive Flex Deck settings in control pad

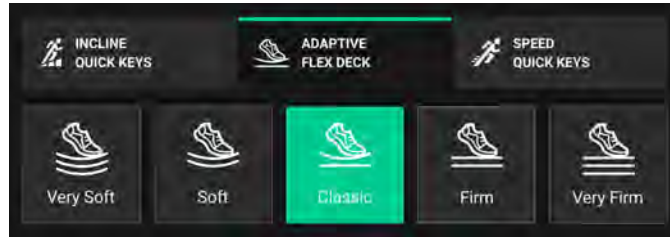

### Speed settings in control pad

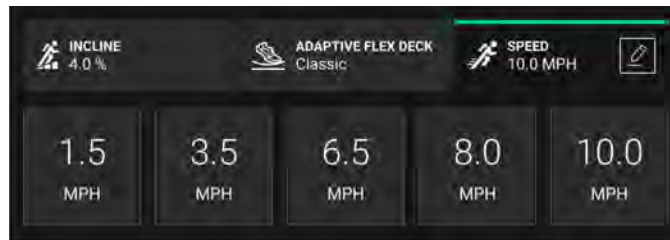

## Symbio Upright LifeCycle and Symbio Upright SwitchCycle

The left handle controls resistance down. The right handle controls resistance up.

Left Handle, Resistance Down

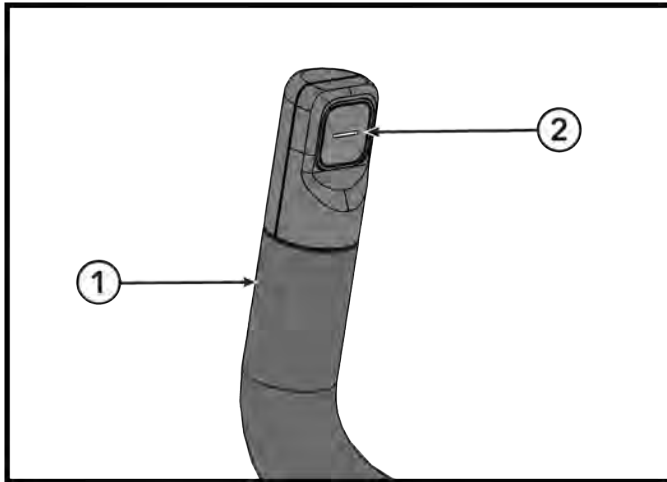

Right Handle, Resistance Up

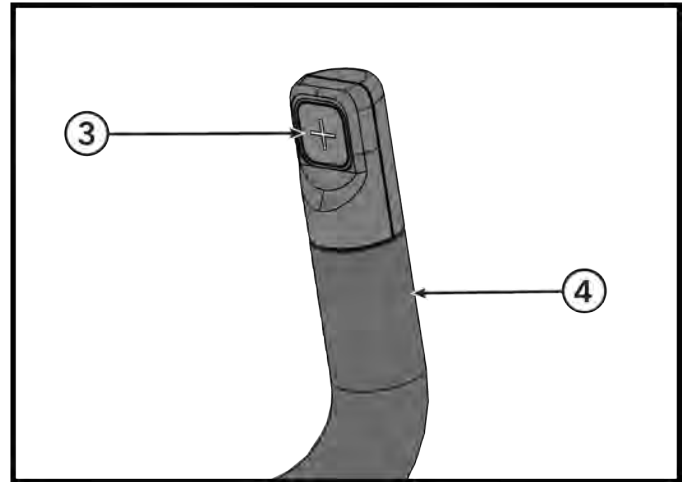

Item	Description	Qty.
1	Left Handle	1
2	Resistance Down	1
3	Resistance Up	1
4	Right Handle	1

The activity zone has three default resistance levels, resistance up, resistance down, and STOP.

### Activity Zone

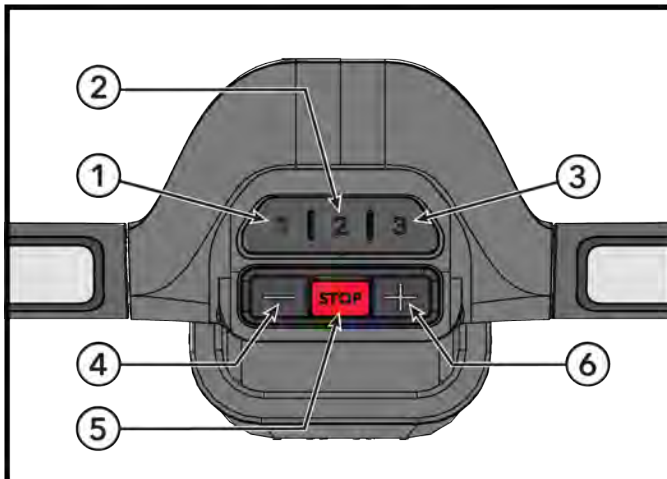

Item	Description	Qty.
1	Resistance Level 1 Quick Key LifeCycle 5, SwitchCycle 20	1
2	Resistance Level 2 Quick Key LifeCycle 10, SwitchCycle 40	1
3	Resistance Level 3 Quick Key LifeCycle 15, SwitchCycle 60	1
4	Resistance Down	1
5	Stop (SwitchCycle model only)	1
6	Resistance Up	1

To program quick keys, select desired resistance level. Once achieved, press and hold quick key for 3 seconds to program the quick key. Process can be repeated for remaining quick keys if desired.

**NOTE:** When one of the Activity Zone buttons are pressed, the backlight for that specific button will light indicating which quick-select level was activated. The backlight for these buttons will remain off until selected by the user, or the resistance level matching the pre-selected levels.

## Recumbent Cycle

The left handle has media controls for volume up, volume down, channel up, and channel down.

The right handle has resistance controls for resistance up and resistance down.

**Left Handle Media Controls**

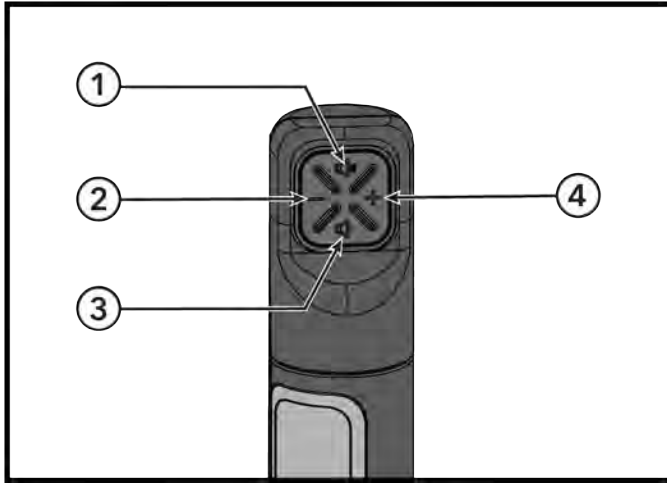

**Right Handle Resistance Controls**

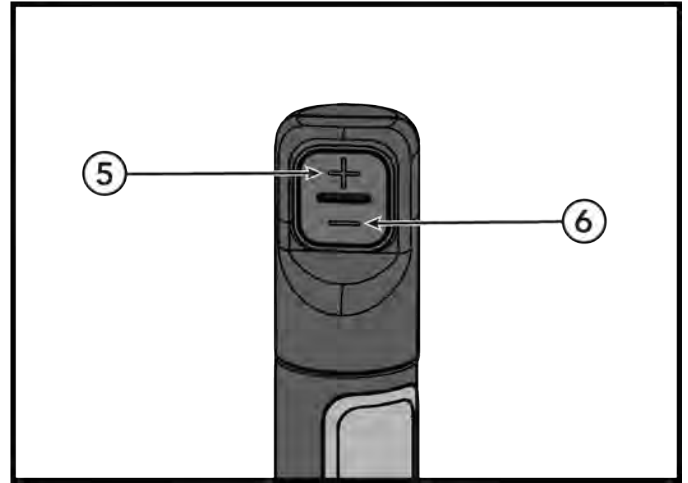

Item	Description	Qty.
1	Volume Up	1
2	Channel Down	1
3	Volume Down	1
4	Channel Up	1
5	Resistance Up	1
6	Resistance Down	1

# Device Connection

## Bluetooth® Devices

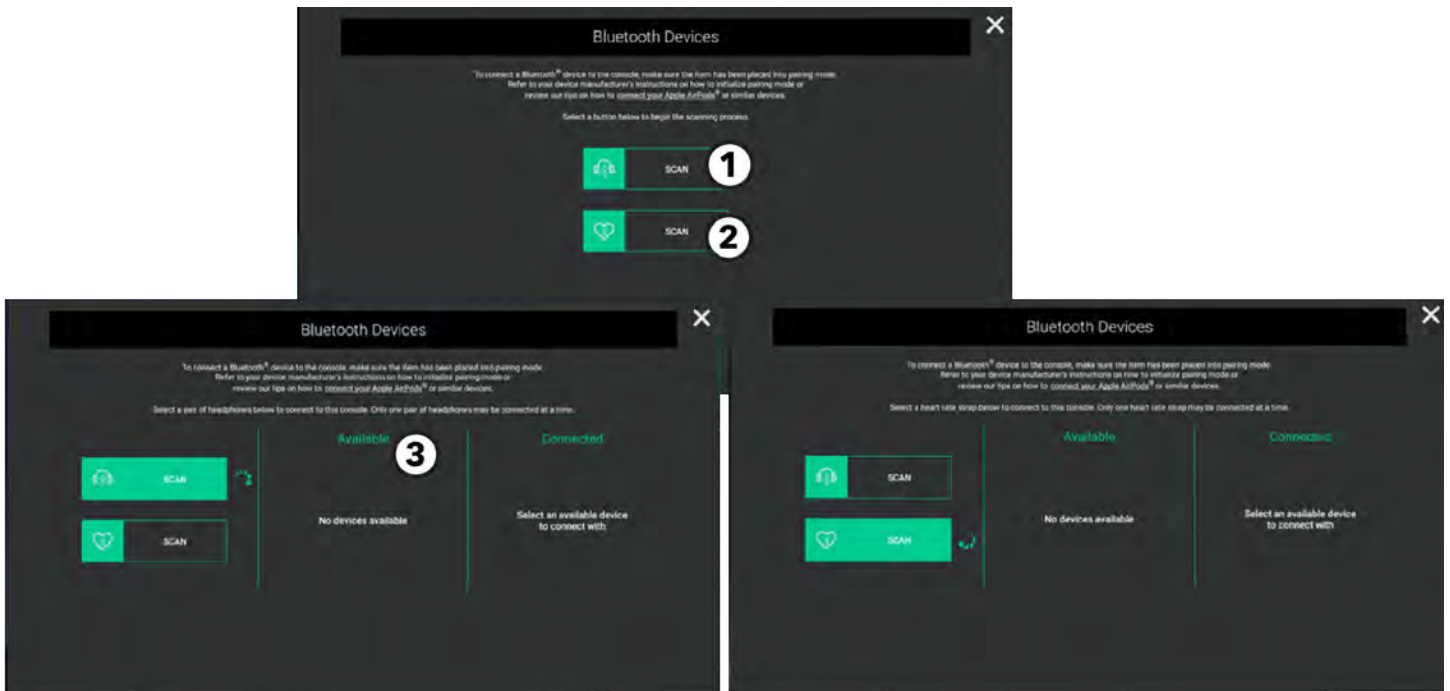

Bluetooth Device menu offers two scanning options:

- Headphone
- Heart rate chest strap

### 1. Headphone

Press to scan for available Bluetooth Devices.

**NOTE:** Make sure your headphones are in pairing mode. Headphones using a low energy Bluetooth signal or single ear headphones are not compatible.

**NOTE:** STB Sync and Set Top Box on the floor configurations do not allow Bluetooth audio to be streamed from TV to headphones.

### 2. Heart Rate Chest Strap

Press to scan for available Bluetooth Devices (example: ANT+)

### 3. Available Devices

Scroll through the list of available devices. Click the + symbol to pair your device.

### 4. Heart Rate Symbol

The heart rate symbol on the upper, left-hand corner of the screen will light up.

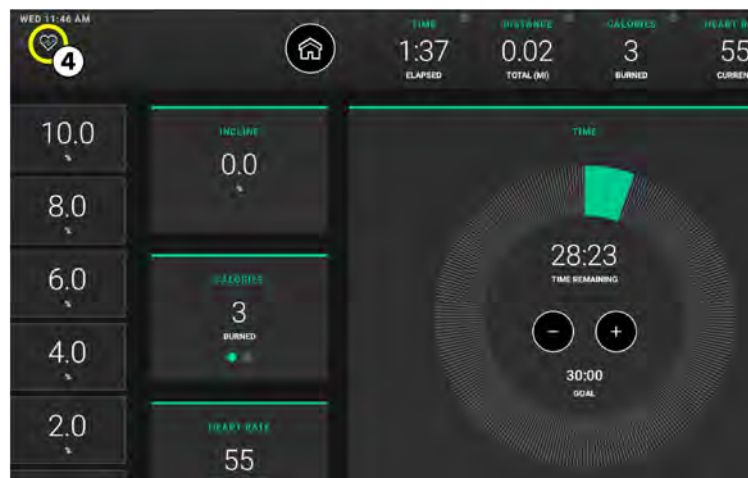

# Apple Watch®



Press the Connect to Apple Watch button  to learn more about connecting your Apple Watch device.

1. At any time prior to the workout summary screen, place your Apple Watch at the bottom left-hand corner of the wireless charger station near the NFC reader. **The watch face must be facing the console to connect.**

**NOTE:** Users can also open the workout app on the Apple Watch and hold near the reader to get started.

2. The Apple Watch is connected when the ∞ symbol is apparent in the upper, left-hand corner of the screen.



## Samsung Galaxy Watch®



Press the Samsung Galaxy Watch button  to learn more about connecting your Samsung Galaxy watch device.

1. At any time prior to the workout summary screen, place your Samsung Galaxy Watch at the bottom left-hand corner of the wireless charging station near the NFC reader. **The watch face must be facing the console to connect.**

**NOTE:** NFC setting on watch must be turned on.

2. The Samsung Galaxy Watch is connected when the watch symbol is apparent in the upper, left-hand corner of the screen.

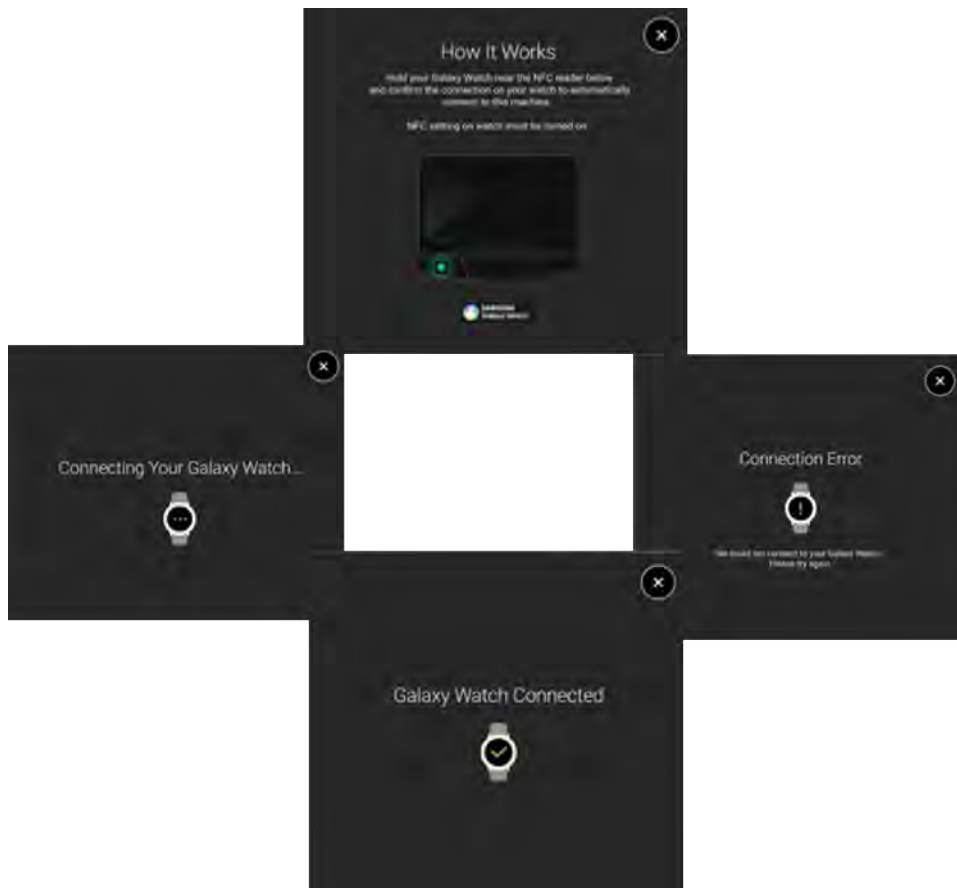

## The Optional Polar® Telemetry Heart Rate Chest Strap

The Polar telemetry heart rate monitoring system transfers heart rate signals to the console when electrodes are pressed against the skin. These electrodes are attached to a Polar telemetry heart rate chest strap that the user wears during the workout. The Polar telemetry heart rate chest strap is optional. Contact [Life Fitness Customer Support Services](#) to order.

See diagram for correct positioning of the Polar telemetry heart rate chest strap. The electrodes (A), which are the two grooved surfaces on the underside of the strap, must remain wet to transmit accurately the electrical impulses of the heart back to the receiver. Moisten the electrodes. Then, secure the Polar telemetry heart rate chest strap as high under the chest muscles as possible. The strap should be snug, but comfortable enough to allow for normal breathing.

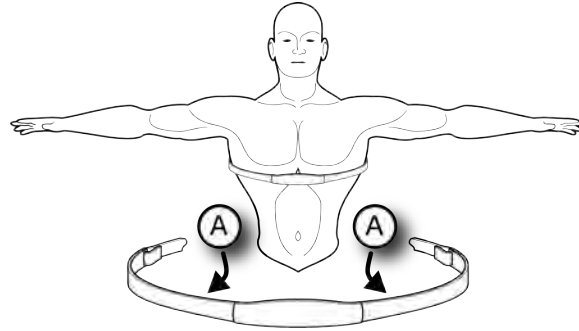

The transmitter strap delivers an optimal heart rate reading when the electrodes are in direct contact with bare skin. However, it functions properly through a thin layer of wet clothing. If it becomes necessary to re-moisten the Polar telemetry heart rate chest strap electrodes, grasp the center of the strap, pull it away from the chest to expose the two electrodes, and re-moisten them.

**NOTE:** If the Lifepulse system sensors are grasped while the chest strap is worn, and if the signals from the sensors are valid, the on-board computer uses these sensor signals for calculating the heart rate instead of those transmitted by the Polar telemetry heart rate chest strap.

**NOTE:** During the setup of a heart rate zone training workout, the user will be required to enter a start-up speed. If a Polar telemetry heart rate chest strap is not detected, the maximum allowable speed is 4.5 MPH / 7.2 KPH (Treadmills only). If a Polar telemetry heart rate chest strap is detected, users can workout at the maximum allowed speed set in the **Configuration Manager** menu.

# Qi® Wireless Induction Charger

How to use:

1. Place your device on the wireless rubber charging station indicated with the charging symbol.

Symbio Incline Elliptical

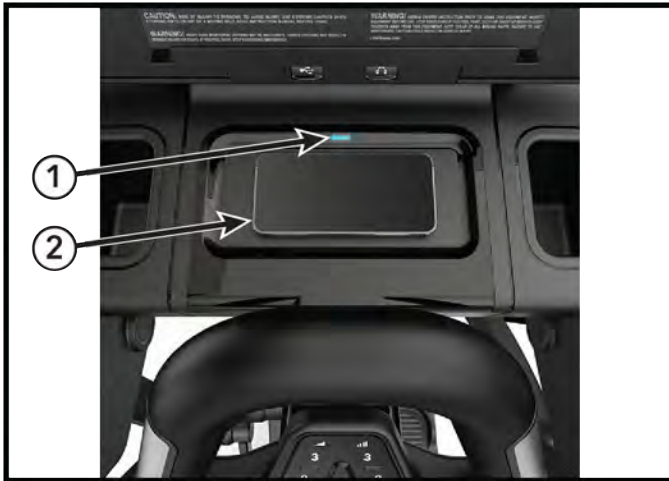

Symbio Recumbent Cycle



Symbio Runner



Symbio Upright LifeCycle and SwitchCycle



Item	Description	Qty
1	Blue Indicator Light	1
2	Device on Wireless Charging Station	1

2. If your device supports Qi Wireless Charging, the blue indicator light will turn blue along with a notification on your mobile phone that the device is charging.

**NOTE:** See [Console Specifications](#) for Qi Wireless Induction Charger specifications.

**NOTE:** For troubleshooting information see [Troubleshooting - Wireless Charger](#).

### Disclaimers and Precautions:

- Supports both Android and Apple Devices and their fast charge power profiles.
- The Wireless Charger is designed for phone charging only. It is not guaranteed to charge other peripheral devices like AirPods or Smart watches.
- Do not place the mobile phone on the wireless charger when conductive materials, such as metal objects and magnets, are placed between the mobile phone and the wireless charger. The mobile phone may not charge properly or may overheat, or the mobile phone and the cards may be damaged.
- Do not place the mobile phone on the wireless charger with a credit card or radio frequency identification (RFID) card (such as a transportation card or a key card) placed between the back of the mobile phone and the mobile phone cover.

- Keep credit cards and RFID cards (such as transportation or key cards) away from charging area.
- If a phone case stores credit cards or other RFID based cards, remove phone case before using wireless charger.
- Depending on the location of the mobile phone's wireless charging coil, your mobile phone may not charge properly. Adjust your mobile phone as needed until the charging indicator light is on and/or your mobile phone indicates it is charging.
- Wireless charging may not work properly if you have attached a thick case to your mobile phone. If your case is thick, remove it before placing your mobile phone on the wireless charger.
- If you connect a charger to the mobile phone during wireless charging, the wireless charging feature will be unavailable.
- If you are using your phone with a connected headset, place the phone in the landscape position. Placing your phone in the portrait position may move its charging coil out of position to charge.
- If you are using an attached wireless charging case on your mobile phone, never place just the case on the charging pad. This may overheat the charging pad and/or the case, and has a risk of fire and injury.
- The wireless charger does not have a power switch.

## The Lifepulse™ System

The patented Lifepulse system sensors are the built-in heart rate monitoring system on this product. For the most accurate reading possible, during a workout:

- Grasp the sensors firmly.
- Hold each sensors at the midpoint.
- Keep hands steady and in place.

### Treadmill shown for reference



The console displays the heart rate within 10 to 40 seconds after the user grasps the sensors. The following factors may affect a Lifepulse reading:

- incorrect hand placement on the sensors
- upper body activity, lotion or dirt on hands
- excessive or insufficient pressure when gripping the sensors

**NOTE:** Do not attempt to grasp the sensors on a treadmill at speeds above 4.5 MPH or 7.2 KPH. For these speeds, the use of a Polar telemetry heart rate chest strap is recommended.

## How To Adjust Smart Lighting

The base is equipped with lighting that can be tuned On or Off, has three brightness setting, and 16 colors.

1. Select **Language** icon from Attract Screen to access the **Select Language** screen.

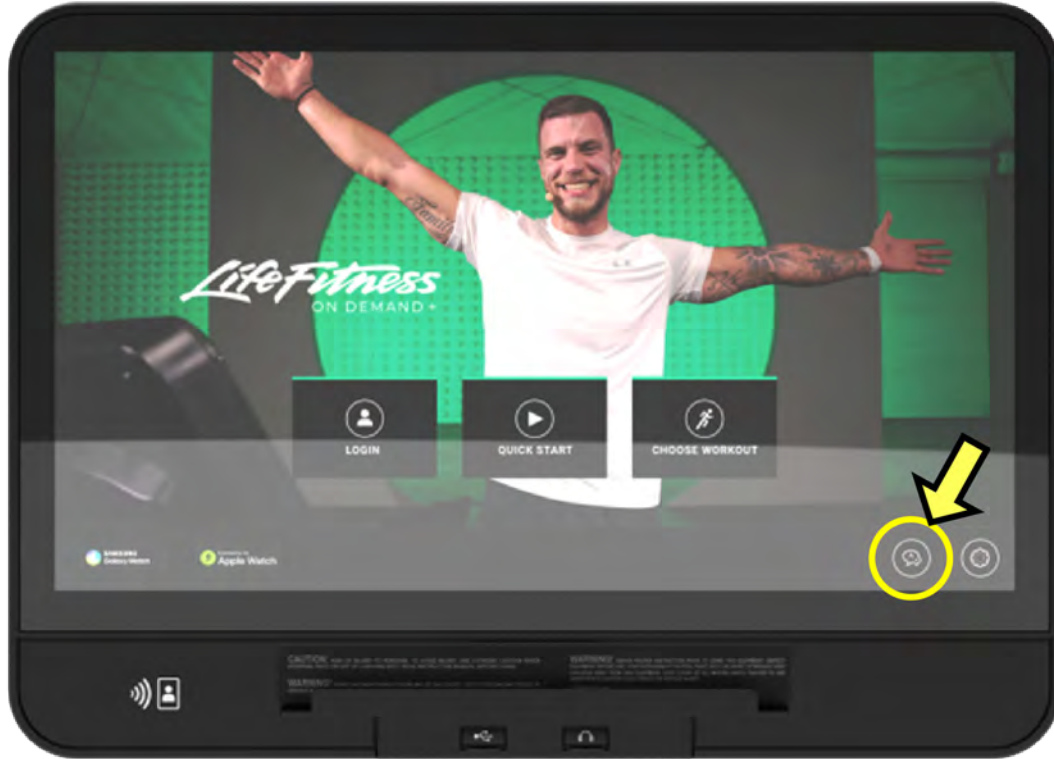

2. Tap the bottom part of the **Select Language** screen in the following sequence: **Lower-Left, Lower-Right, Lower-Left, Lower-Right**.

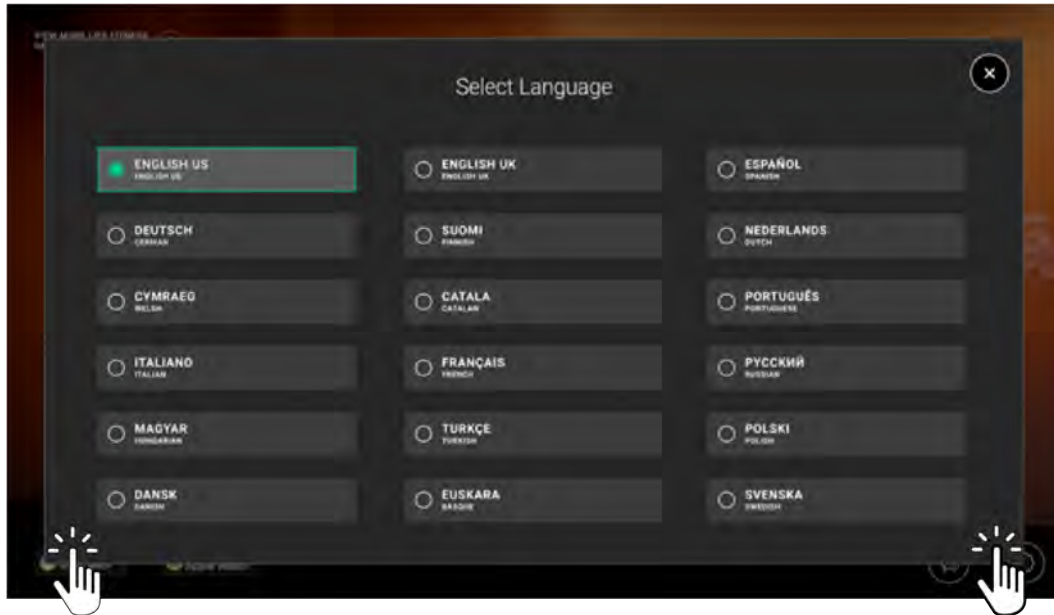

**NOTE:** Make sure you tap INSIDE the black square!

3. Navigate through the System Options menu to **Configuration > Manager**.

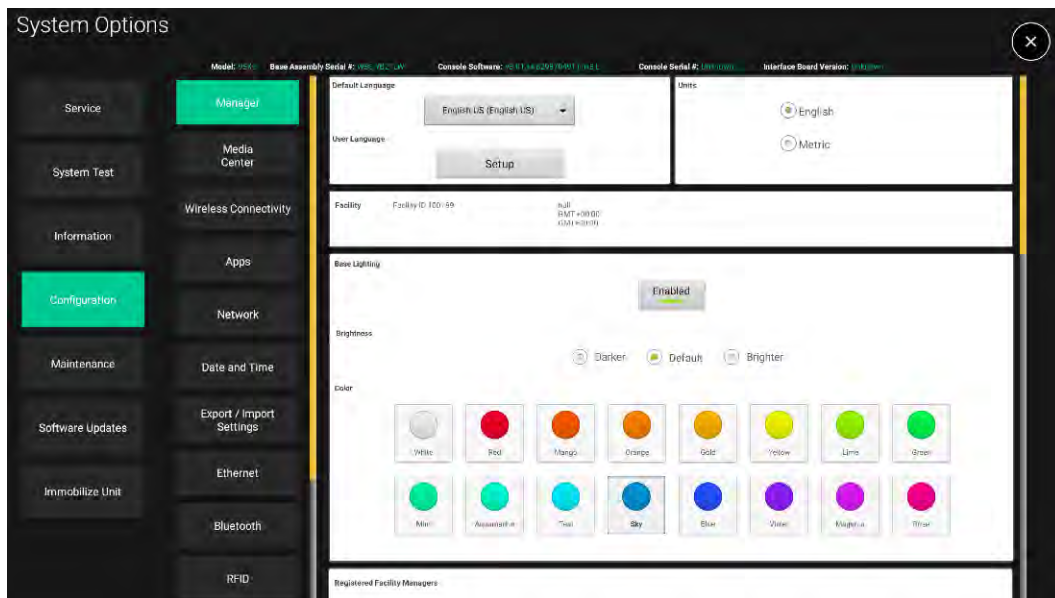

4. Scroll down to **Smart Lighting**.
5. Toggle the **Enabled** button to turn lights On or Off.
6. Adjust the **Brightness** as needed.
7. Adjust the **Color** to your choice of 16 colors.

# 4. Operation

## Home Screen

The intuitive LCD touch screen allows users to:

- Select, set up, monitor, and save workouts.
- Access Entertainment options.

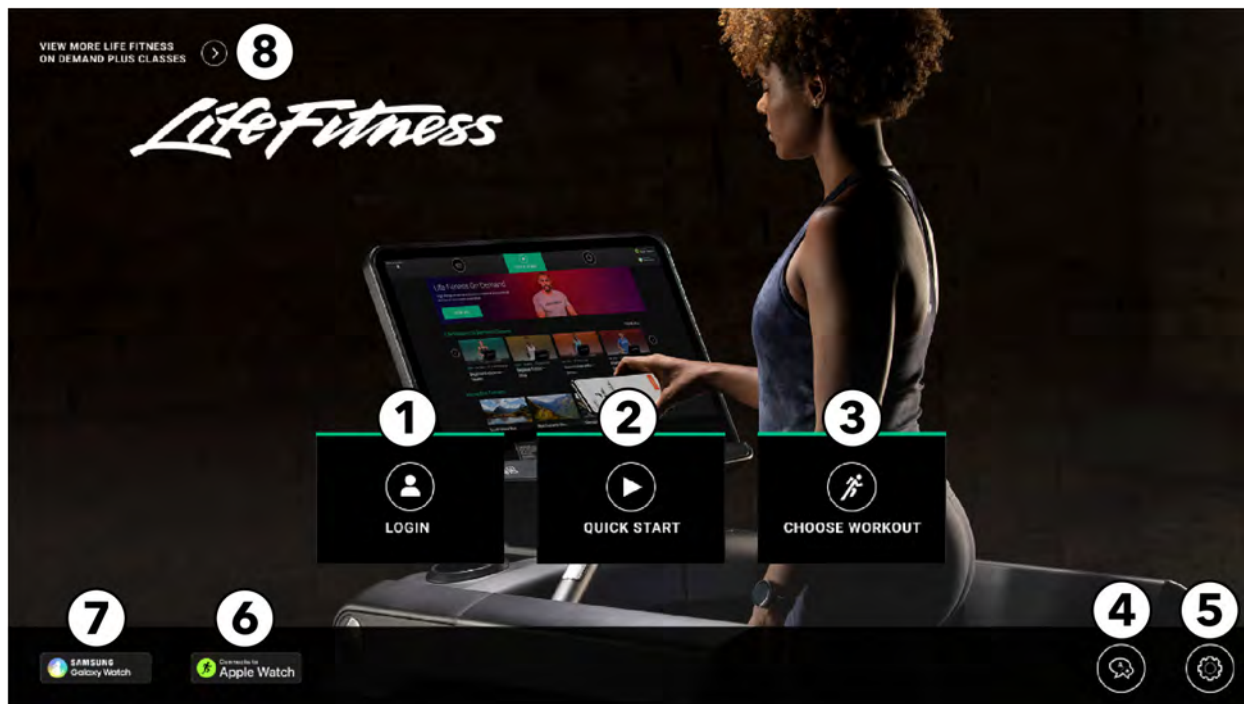

1. **Log In:** Press to log in to your LFconnect or Halo account.
2. **Quick Start:** Press to begin a workout immediately without setup or selecting a goal.
3. **Choose Workout:** Select a workout from the following categories:
  - Popular Workouts
  - On Demand instructor-led classes
  - Interactive Terrains
  - Standard Goals
  - Fitness Tests
  - Quick Start
4. **Language:** Select a language to use during a workout.
5. **Settings:** Press to enter your weight or change your units (imperial or metric).
6. **Connects to Apple Watch®:** Press to learn more about connecting your Apple Watch device.
7. **Samsung Galaxy Watch®:** Press to learn more about connecting your Samsung Watch device.

8. Access On-Demand Workouts Library: Press to view the On-Demand Workouts library.

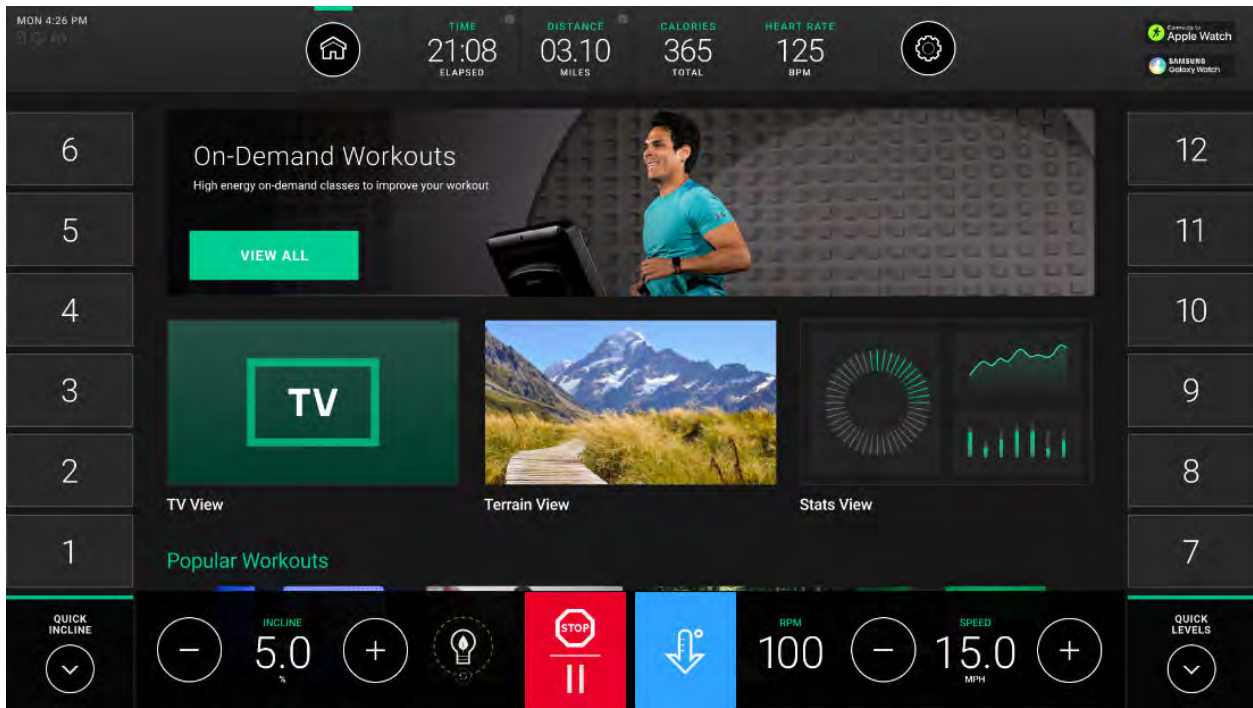

## General Settings

Choose settings for your workout. These settings can also be accessed within a workout.

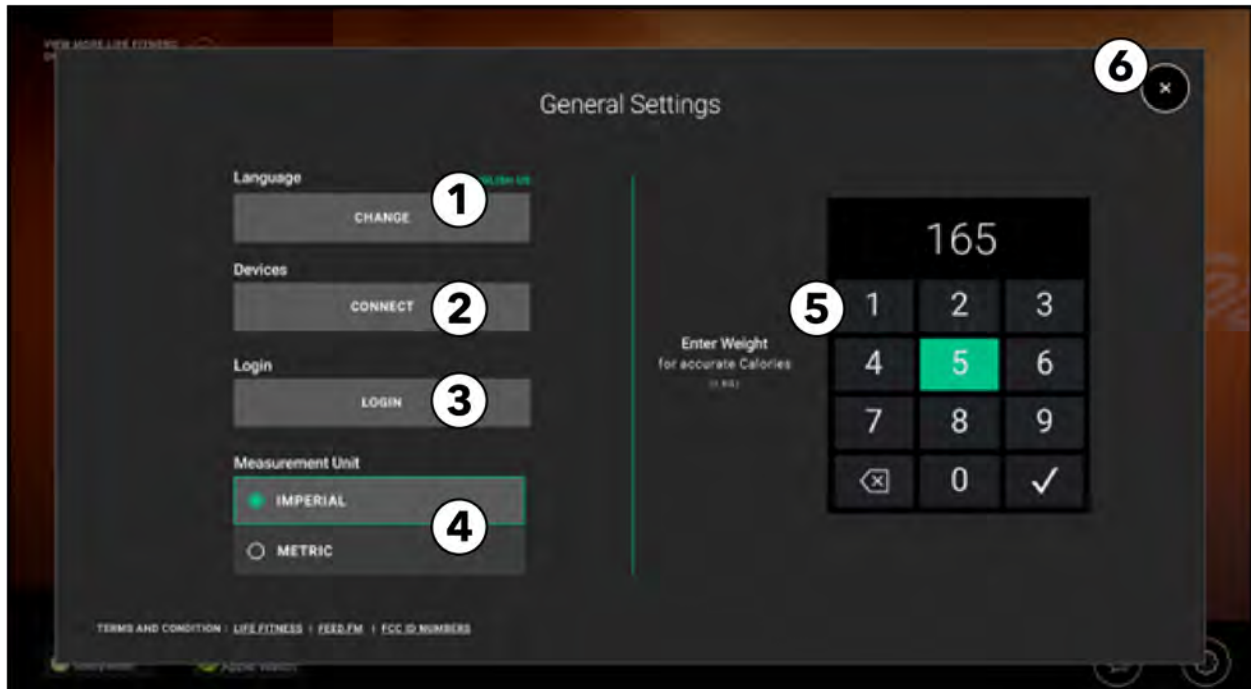

1. **Language:** Select a language to use during a workout.
2. **Devices:** Scan for Bluetooth enabled headphones or Heart Rate devices.
3. **Login:** Log in to your LFconnect or Halo account.
4. **Measurement Unit:** Choose Imperial or Metric.
5. **Enter Weight:** Use the numeric keypad to input a weight value.
6. **Exit:** Press to exit the Settings screen and return to the Home Screen.

## Select Language

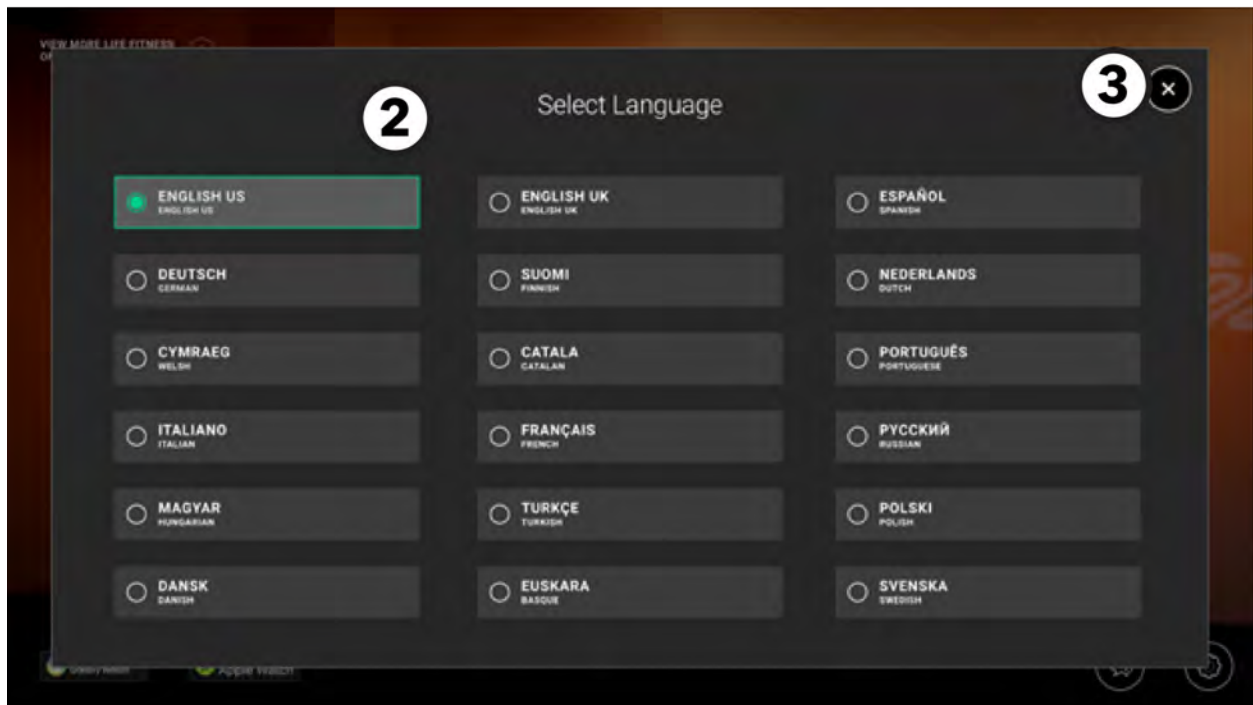
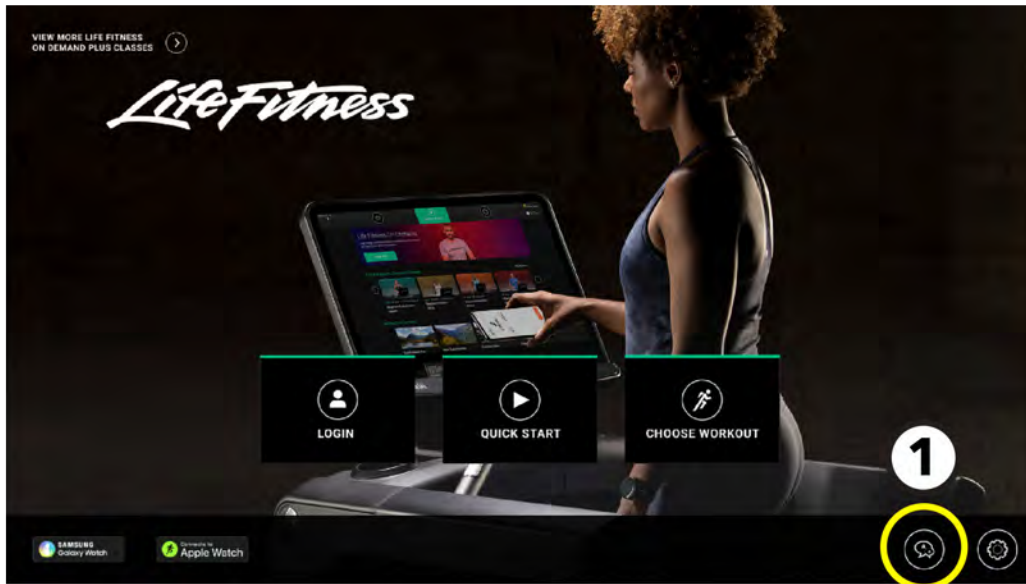

1. Press the **Select Language** icon on **Home** screen.
2. Choose desired language from the **Select Language** screen.  
Users can select a language to use during a workout.

**NOTE:** Only the specific languages enabled by the manager will be displayed.

After a selection is made, the language is saved, the **Select Language** screen is closed and the **Home** screen appears in the selected language.

3. **Exit** the **Select Language** screen and return to the **Home** screen.

## Choose Workout

Scroll the **Choose Workout** screen to view available workout options.

**NOTE:** Available workouts vary by base type.

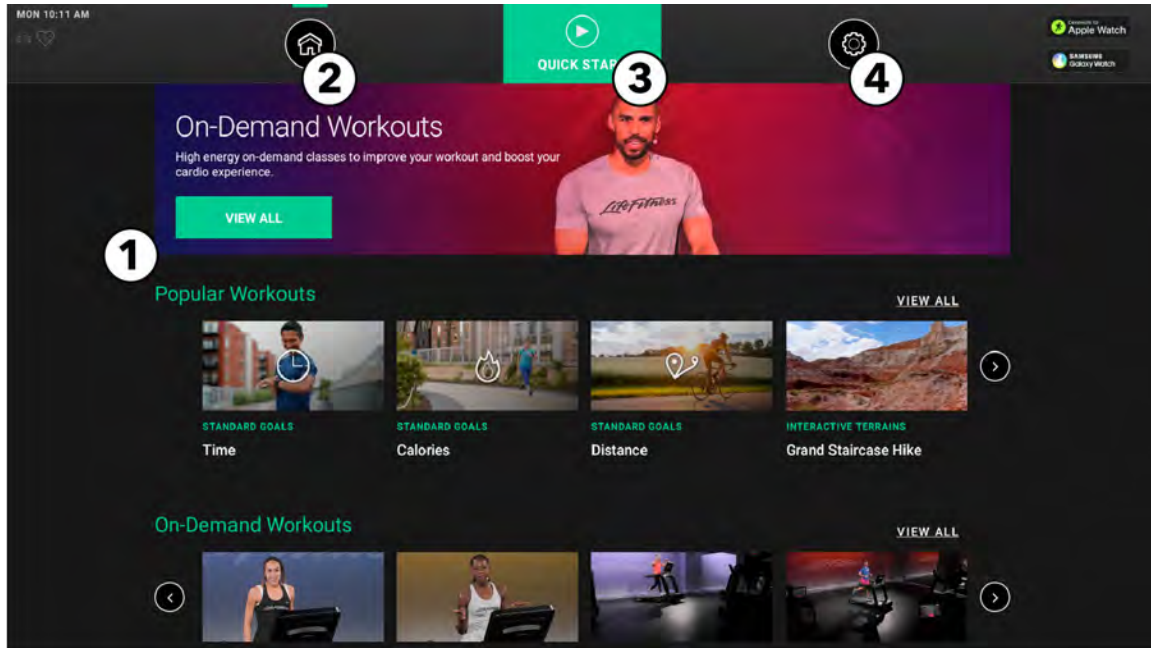

1. Scroll through the Workout Options:

- **Popular Workouts** - Select a workout that is frequently chosen by exercisers.
- **On-Demand Workouts** - Select an instructor-led class streamed through the internet.
- **Interactive Terrains** - Select from available interactive terrain video courses.
- **Standard Goals** - Choose a workout based on desired goal.
- **Fit Tests** - Select from available fitness tests.
- **Quick Start** - Begin a workout immediately without setup or selecting a goal.

Press on desired workout to access a description about the selected workout.

Press **Start Workout** to access workout setup.

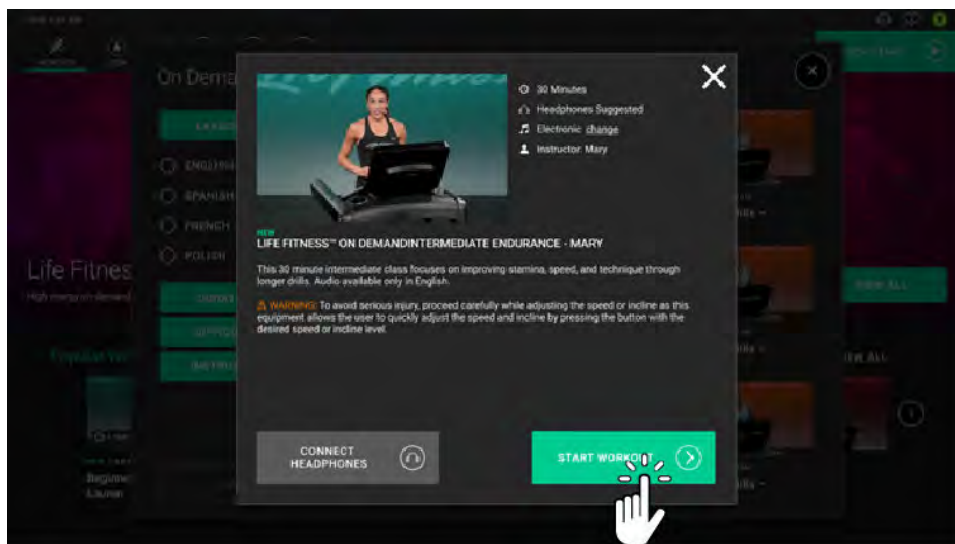

2. **Home Screen** - Press to return to the Home Screen.

3. **Quick Start** - Press to begin a workout immediately without setup or selecting a goal.

4. **General Settings** - Press to access the General Settings options.

## In-Workout Views and Entertainment Choices

Users can select various views and entertainment options during workouts.

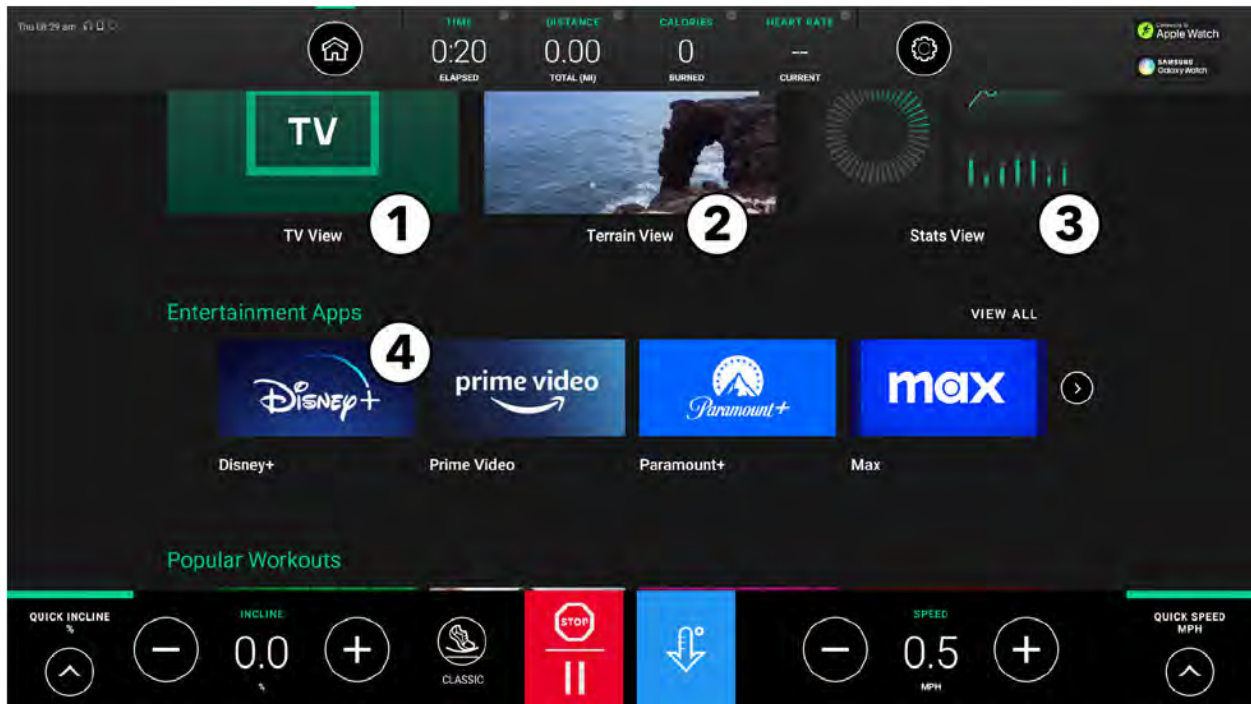

1. **TV View:** Choose to watch TV during a workout.
2. **Terrain View:** Choose to workout watching a video course, shot in first person perspective through landscapes, cityscapes, and events.
3. **Stats View:** Choose to view up-to-date workout stats during a workout.
4. **Entertainment Apps:** Choose from a selection of entertainment apps to enjoy during a workout.

## TV View

Users must be in a workout to access TV View.

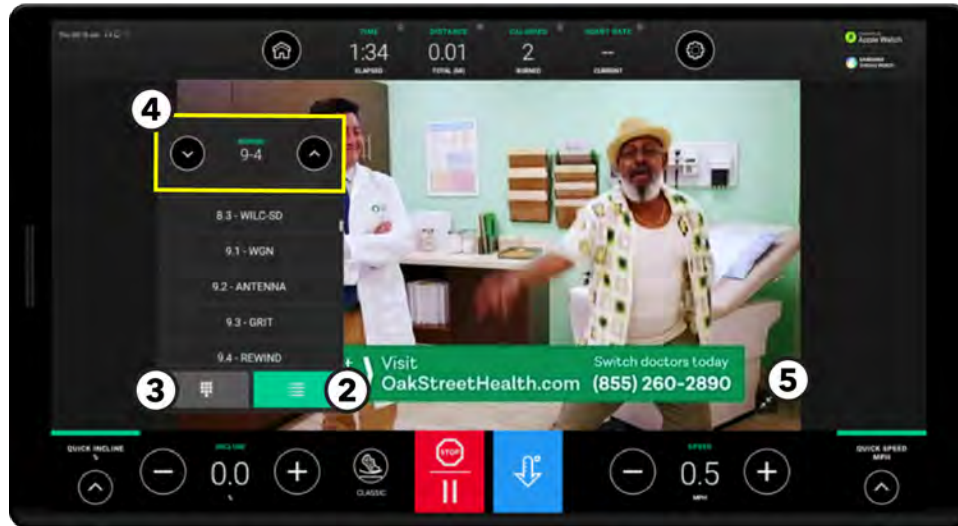
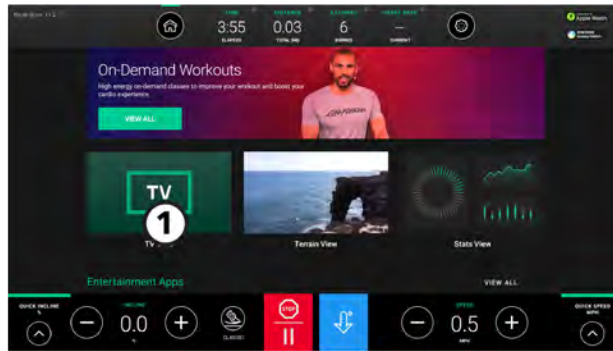

1. Press **TV View** to watch TV.

2. **Channel List**

Press to access a list of all available channels.

**NOTE:** Shown in image.

3. **Channel Keypad**

Press to access a numeric keypad to input channel number.

4. **Up and Down Arrows**

Use the arrows to scroll channels.

5. **Screen Size Toggle**

Press to toggle between Full and Minimized screen sizes.

**For Symbio Runner, TV channel settings in control pad**

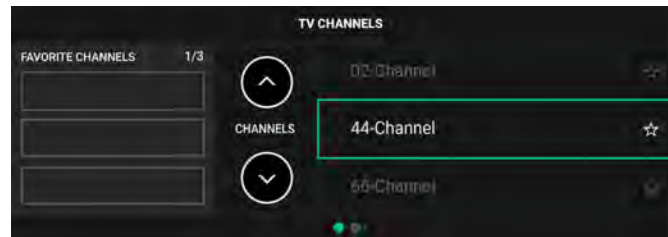

# Terrain View

Users can select **Terrain View** to enjoy working out to a video course

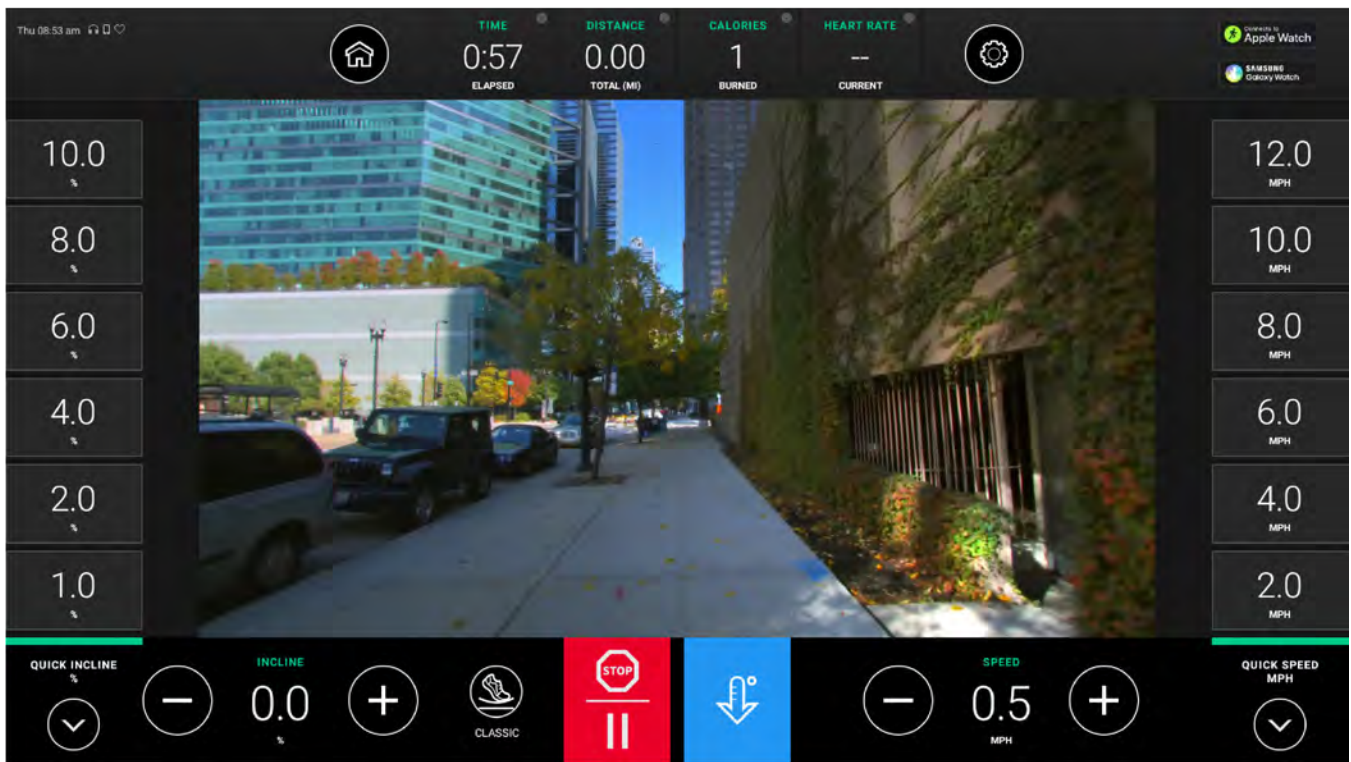
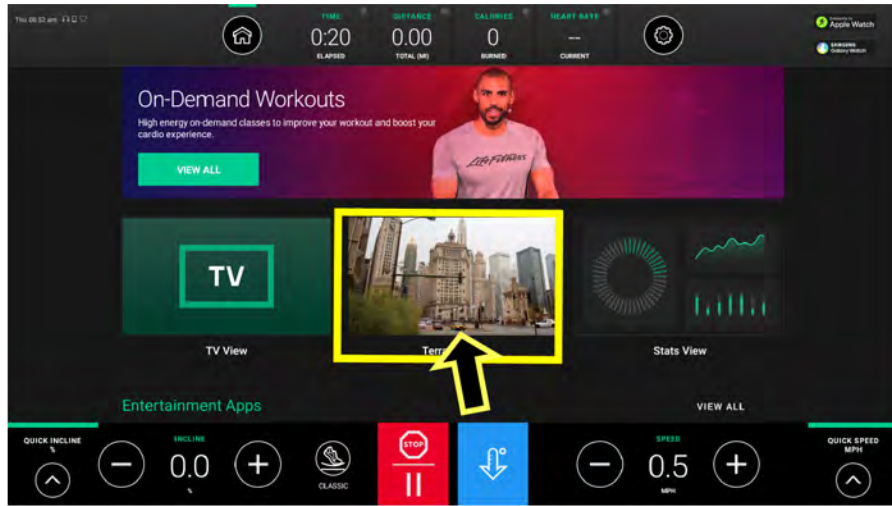

## Stats View

Users can view and toggle between workout stats during a workout.

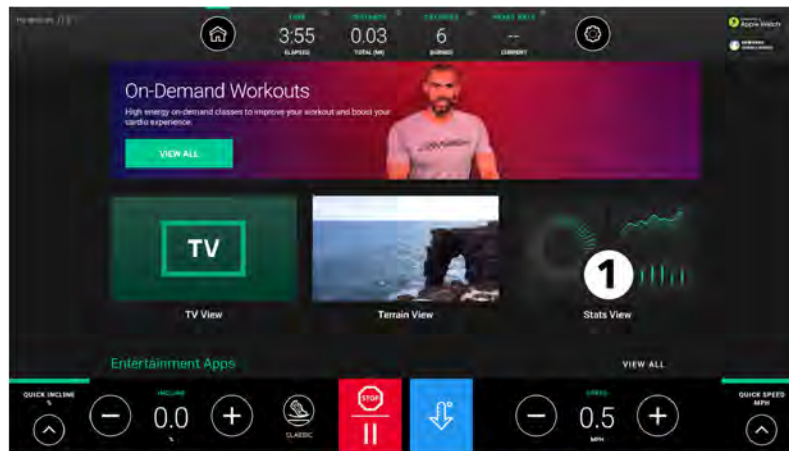

**NOTE:** Time goal on a treadmill is selected workout shown in image as an example.

1. Press **Stats View**.
2. **Workout Profile** is shown in the center tile.
  - Visual of goal progress
  - Increase or decrease shown metric.

- Swipe for additional workout profiles.

**NOTE:** Available workout profiles vary depending on base type and selected workout.

### Laps View

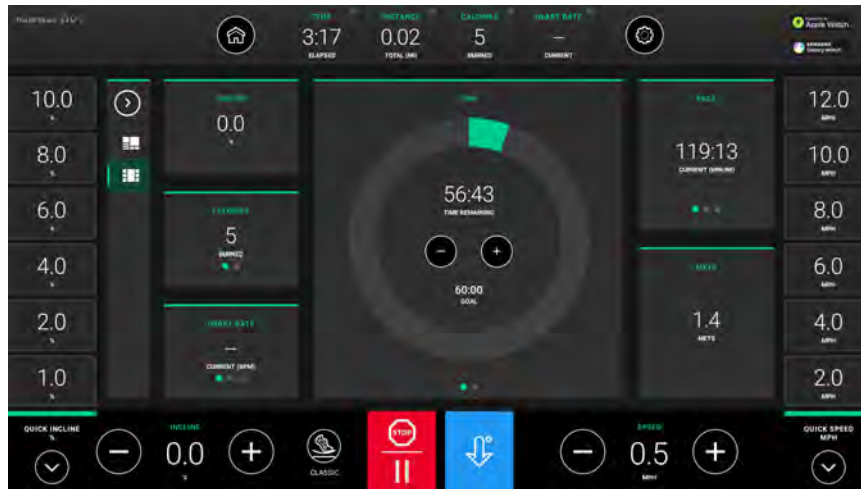

- Stats and Additional Stats**

**NOTE:** Stats available vary depending on base type and selected workout.

Stats are shown across the top bar and on the side tiles. Additional stats are available:

- Press the **down arrow** next to stat on the top bar.
- Swipe the circles on the bottom of the stats shows on the side tiles.

### Available Stats on Down Arrow on Top Bar / Circles on Tiles

Time	Distance	Calories	Heart Rate	Pace
Time Elapsed	Total Distance (mi / km)	Calories Burned (total)	Current (BPM)	Current Pace (min / mi or min / km)
Time Remaining	Climbed (feet)	Calories Burned (per hour)	Average (BPM)	Average Pace (min / mi or min / km)
Current Pace (min / mi or min / km)		Energy (METS)	Max (BPM)	Average Speed (mph / kph)
Average Speed (mph / kph)		Power (WATTS)		

- Quick Key Buttons**

**NOTE:** Quick-Touch selections vary by base type.

- **Incline:** Press one of the quick key incline buttons to quickly change incline during workout.
- **Speed:** Press one of the quick key buttons speed to quickly change the speed during workout.
- **Resistance:** Press one of the quick key resistance buttons to quickly change the resistance during workout.
- **Level:** Press one of the quick key level buttons to quickly change the level during workout.

- Home Screen**

Press to go back to the Home Screen.

**NOTE:** PowerMill steps and Treadmill belt keeps moving when the **Home Screen** is pressed during a workout.

## Advanced Stats View Screens

Toggle between **Advanced** and **Basic** views by tapping these icons.



## Symbio Runner



# Symbio Incline Elliptical

## Advanced Stats View Screen

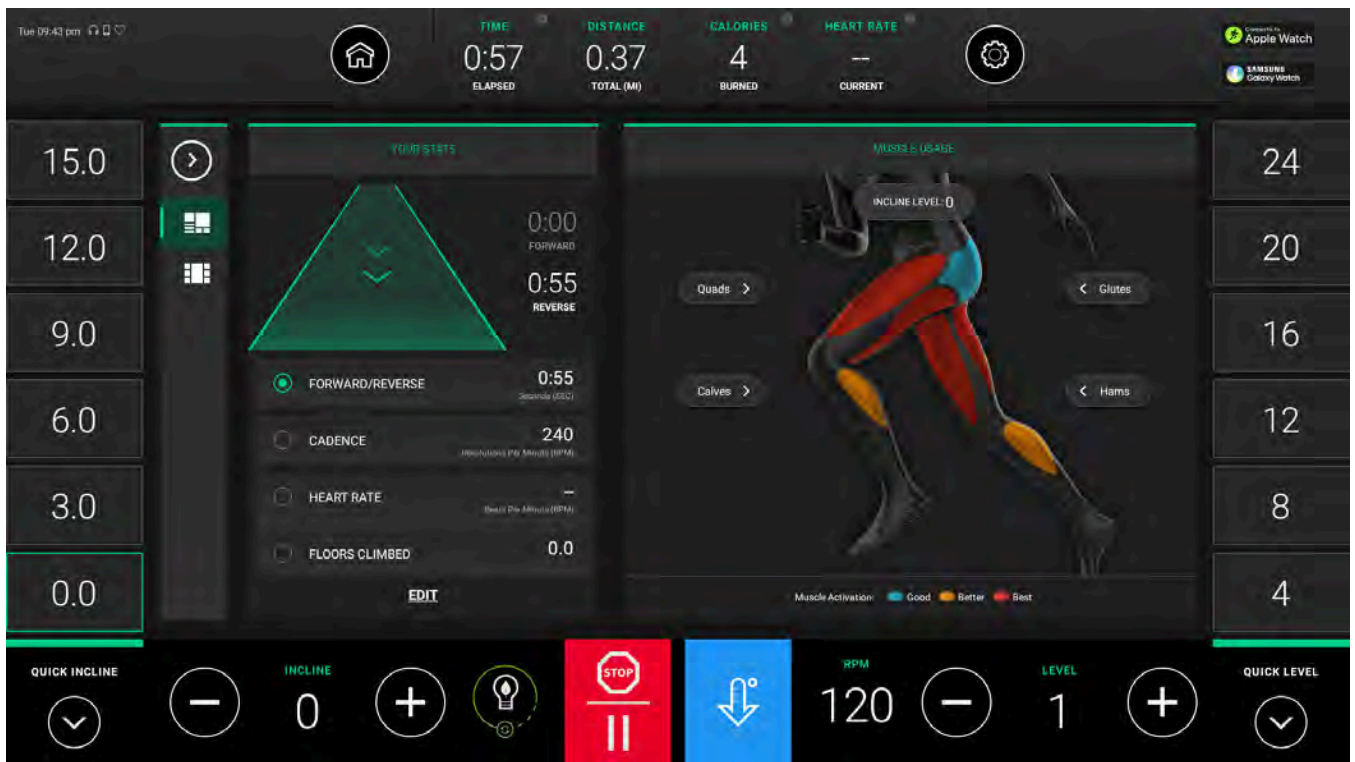

Click on the various muscle groups in the animation to instantly adjust to the optimal incline to target that muscle.

## Symbio Upright LifeCycle and Symbio Upright SwitchCycle

Line Graph



Power Graph



## Symbio Recumbent Cycle

Line Graph

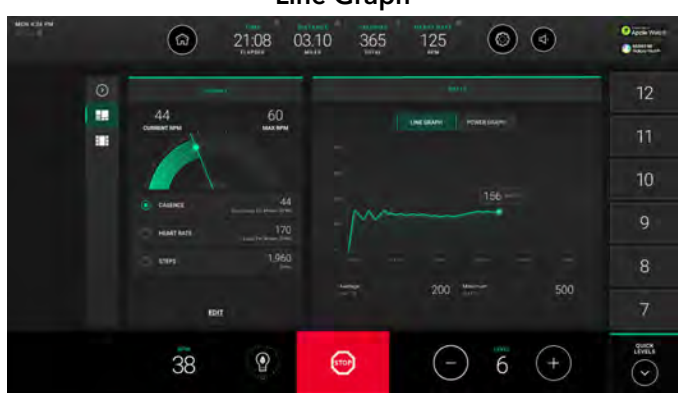

Power Graph



## Pause Workout

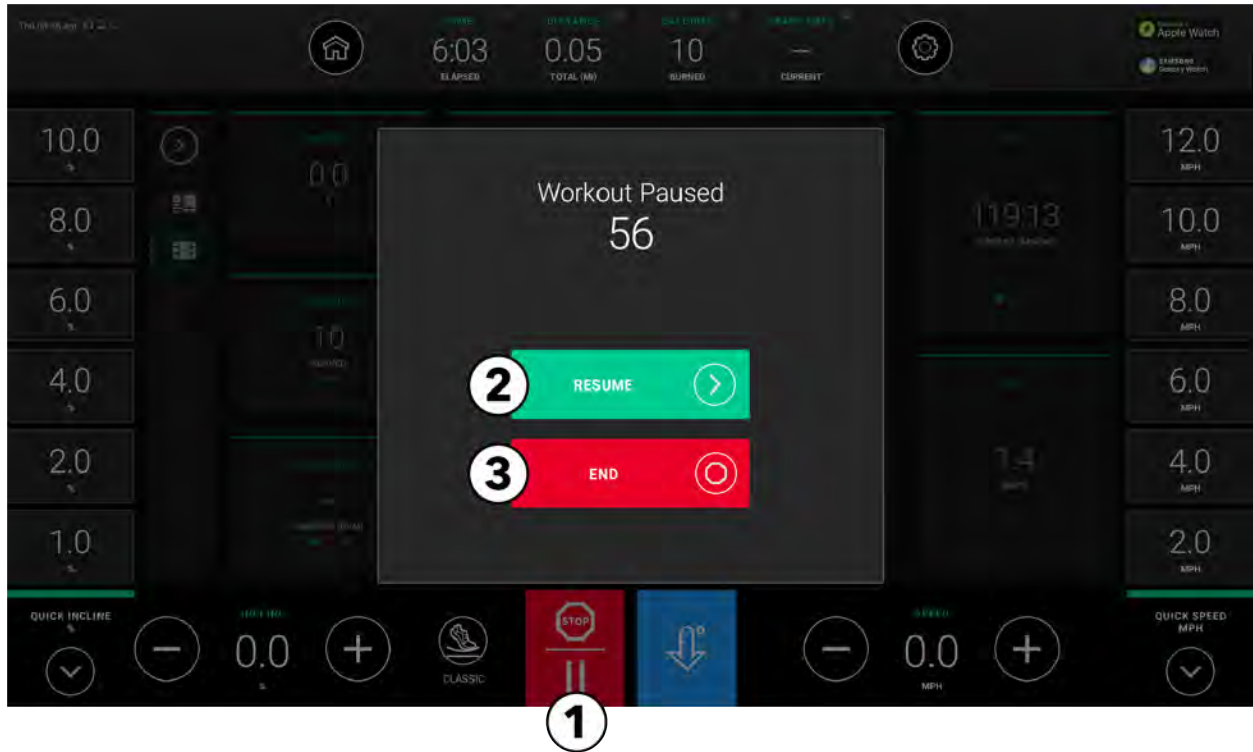

1. Press the **Pause / Stop** button to pause a workout.  
Choose one of the following options while in Pause mode:
2. **Resume**  
Press to continue current workout.
3. **End Workout**  
Press to end current workout and view workout summary.

## Cool Down

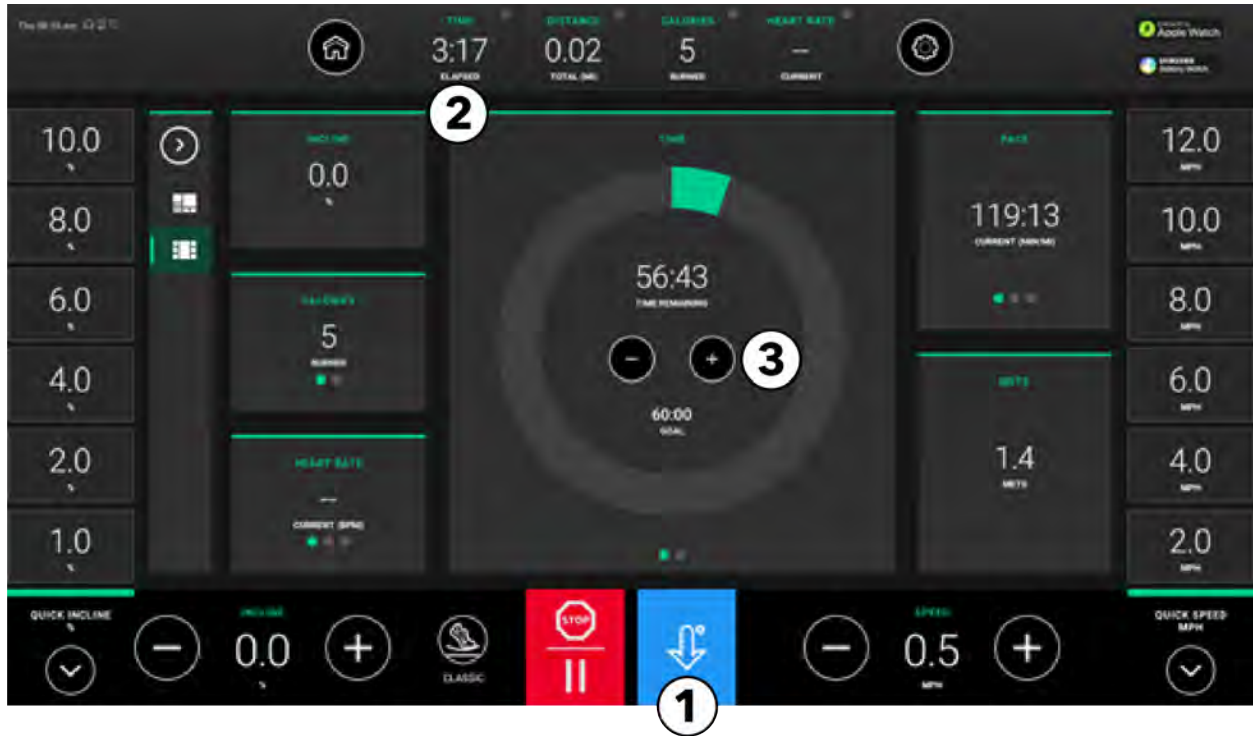

1. Press the **Cool Down** button anytime during a workout to start a Cool Down mode.

### 2. Time Display

- **Time** will change to **Cool Down** when the Cool Down mode is entered.
- The time display initially shows the amount of time in minutes that a specific workout is required to be in Cool Down mode.
- The time display will countdown until it reaches 00:00.

### 3. Increase / Decrease Time

- Press **-** to decrease the cool down time by 1-minute intervals.
- Press **+** to increase the cool down time by 1-minute intervals.

**NOTE:** The speed on Treadmill bases automatically decreases after pressing the **Cool Down** button.

# Hybrid Mode

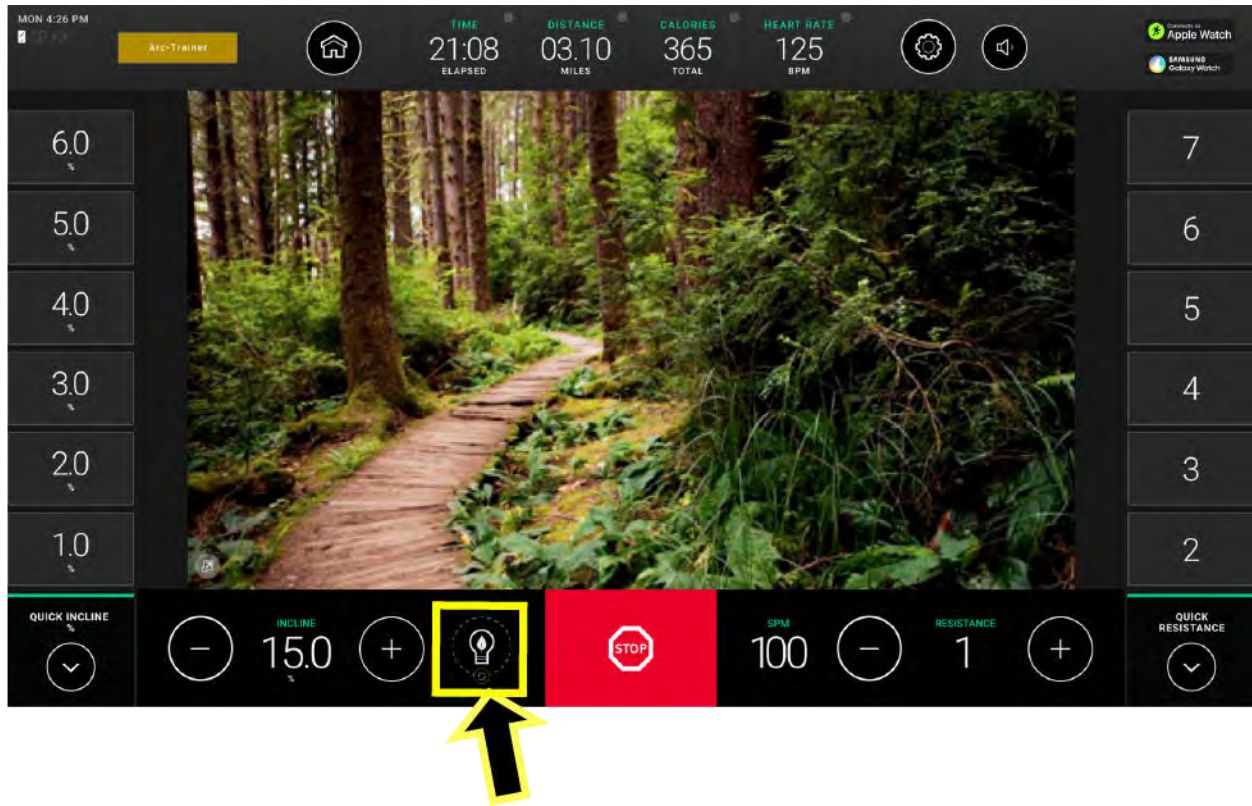

**NOTE:** Hybrid Mode exists on non-powered equipment (Cross-Trainers and bikes) only!

Hybrid Mode (if enabled) shows the light bulb on the bottom bar of the In-Workout view. The light bulb will animate to show its filling up as the user pedals to produce electricity reducing the power draw. The workout summary screen will show a message about the workout reducing an amount of energy to power this equipment.

# 5. Workouts

## Workouts List

Symbio Runner	Symbio Incline Elliptical	Symbio Recumbent Cycle, Symbio Upright LifeCycle®, and Symbio Upright SwitchCycle
<b>Quick Start</b>	<b>Quick Start</b>	<b>Quick Start</b>
<b>Standard Goals</b> <ul style="list-style-type: none"> <li>• Time</li> <li>• Distance</li> <li>• Calories</li> <li>• Climb</li> <li>• Heart Rate               <ul style="list-style-type: none"> <li>• (Moderate, Vigorous)</li> </ul> </li> <li>• Intervals               <ul style="list-style-type: none"> <li>• (Custom, High Intensity, Endurance)</li> </ul> </li> <li>• Starter</li> </ul>	<b>Standard Goals</b> <ul style="list-style-type: none"> <li>• Time</li> <li>• Distance</li> <li>• Calories</li> <li>• Heart Rate               <ul style="list-style-type: none"> <li>• (Moderate, Vigorous)</li> </ul> </li> <li>• Intervals               <ul style="list-style-type: none"> <li>• (Starter, High Intensity, Endurance)</li> </ul> </li> <li>• Constant Power</li> <li>• Adaptive Power</li> <li>• Aerobics</li> <li>• Reverse</li> </ul>	<b>Standard Goals</b> <ul style="list-style-type: none"> <li>• Time</li> <li>• Distance</li> <li>• Calories</li> <li>• Heart Rate               <ul style="list-style-type: none"> <li>• (Moderate, Vigorous)</li> </ul> </li> <li>• Intervals               <ul style="list-style-type: none"> <li>• (Starter, High Intensity, Endurance)</li> </ul> </li> <li>• Constant Power</li> <li>• Adaptive Power</li> <li>• Aerobics</li> <li>• METs</li> </ul>
<b>Fit Tests</b> <ul style="list-style-type: none"> <li>• LF Fit Test</li> <li>• U.S. Navy</li> <li>• U.S. Army</li> <li>• U.S. Marine</li> <li>• U.S. Air Force</li> <li>• WFI Submax Protocol</li> <li>• Physical Efficiency Battery</li> <li>• IPPT</li> </ul>	<b>Fit Tests</b> <ul style="list-style-type: none"> <li>• LF Fit Test</li> <li>• U.S. Navy</li> </ul>	<b>Fit Tests</b> <ul style="list-style-type: none"> <li>• LF Fit Test</li> <li>• U.S. Navy</li> </ul>

## Workout Descriptions

**NOTE:** Available workouts vary depending on base type. See [Workouts List](#).

Quick Start	
Manual workout that skips workout setup and goes straight to workout.	
Standard Goals	
<b>Time Goal</b>	Workout that only has a requirement to end at a specific time duration.
<b>Distance Goal</b>	Workout that only has a requirement to end at specific distance traveled.
<b>Calories Goal</b>	Workout that only has a requirement to end at specific calories burned.
<b>Climb Goal</b>	Workout that only has a requirement to end at a specific elevation climbed.
Heart Rate	
• Moderate	Resistance / Incline will adjust to achieve 65% of max Heart Rate.
• Vigorous	Resistance / Incline will adjust to achieve 80% of max Heart Rate.
Intervals	
• Custom	Create your own interval workout by customizing two different speed buttons. They allow for quick speed changes.
• High Intensity	High intensity interval workout using 2 levels / 2 speeds. Ratio: 1:3 (30 seconds active: 90 seconds recovery). Enter a speed that would be difficult to run for more than one minute. Enter a recovery jogging or walking speed. This workout is intended to improve your maximum speed capabilities and VO <sub>2</sub> max.
• Endurance	Moderate intensity interval workout using 2 levels / 2 speeds. Ratio: 3:1 (180 seconds active: 60 seconds recovery). Enter a speed that would be difficult to run for a 5k. Enter a recovery jogging speed. This workout is intended to improve your endurance at 5k and longer runs.
• Starter	A challenging 1:1 interval workout that progresses from low-intensity to high-intensity intervals.
• 2-Speed	Create your own interval workout by customizing two different speed buttons. They allow for quick speed changes.
• 3-Speed	Create your own interval workout by customizing three different speed buttons. They allow for quick speed changes.
<b>Constant Power</b>	Power will remain constant across speeds. Ideal workout to maintain constant intensity.
<b>Adaptive Power</b>	Power will increase even more with high speeds. Good for interval training.
<b>Aerobics</b>	A guided workout that varies the muscles used and intensity.
<b>Reverse</b>	Split your workouts into both forward and reverse portions.
<b>METs</b>	Choose your calorie burn by selecting constant METs intensity.

<b>Fit Tests</b>	
<b>Life Fitness Fit Test</b>	A 5-minute submaximal test to predict VO <sub>2</sub> max. Estimates cardiovascular fitness and can be used to monitor improvements in endurance every 4 - 6 weeks. See <a href="#">Life Fitness Fit Test</a> for more information.
<b>U.S. Navy Physical Readiness Test (PRT)</b>	A 5-minute distance goal test based on the time needed to complete the required distance and is used by the U.S. Navy and Naval academies to measure aerobic capacity.
<b>U.S. Army Physical Fitness Test (PFT)</b>	A 5-minute physical performance test used to assess muscular endurance and cardio respiratory fitness.
<b>U.S. Marines Physical Fitness Test (PFT)</b>	A physical performance test used to assess muscular endurance and cardio respiratory fitness.
<b>U.S. Air Force Fitness Test</b>	A physical performance test used to assess muscular endurance and cardio respiratory fitness.
<b>WFI Submax Protocol</b>	A graded submax assessment used to predict a fire fighter's aerobic capacity. This test automatically increases speed and incline (treadmill only) until a target heart rate is reached. This assessment replaces the Gerkin assessment. Once the target heart rate has been exceeded for 15 seconds, the program goes into a cool down mode.
<b>Physical Efficiency Battery (PEB)</b>	U.S. Federal Law Enforcement, U.S. Federal Bureau of Investigation, and other federal organizations use for the hiring and maintenance of federal jobs.
<b>Individual Physical Proficiency Test (IPPT)</b>	The 2.4 kilometer portion of a standard physical fitness test utilized by the Singaporean Armed Forces, Police Force and Civil Defense Force.
<b>Candidate Physical Ability Test</b>	This is used to predict the ability to perform basic fire fighting tasks developed by the International Association of Fire Fighters. The test starts out with a 20-second warm up period at a set stepping rate of 50 steps per minute followed by the 3-minute test at a set stepping rate of 60 steps per minute.

## Workout Setup - Data Inputs

### Symbio Runner

Standard Goals	User Input
<b>Time</b>	<ul style="list-style-type: none"> <li>• 3 preset values or use keypad to input desired time</li> <li>• Terrain (<i>Flat, Hill Interval, Rolling Hills, Random, Kilimanjaro</i>)</li> <li>• Level (<i>if Hill Interval, Random, Rolling Hills or Kilimanjaro is chosen</i>)</li> <li>• Speed</li> <li>• Weight</li> </ul>
<b>Distance</b>	<ul style="list-style-type: none"> <li>• 3 preset values or use keypad to input desired distance</li> <li>• Terrain (<i>Flat, Hill Interval, Rolling Hills, Random, Kilimanjaro</i>)</li> <li>• Level (<i>if Hill Interval, Random, Rolling Hills or Kilimanjaro is chosen</i>)</li> <li>• Speed</li> <li>• Weight</li> </ul>
<b>Calories</b>	<ul style="list-style-type: none"> <li>• 3 preset values or use keypad to input desired calories</li> <li>• Weight</li> <li>• Terrain (<i>Flat, Hill Interval, Rolling Hills, Random, Kilimanjaro</i>)</li> <li>• Level (<i>if Hill Interval, Random, Rolling Hills or Kilimanjaro is chosen</i>)</li> <li>• Speed</li> <li>• Weight</li> </ul>
<b>Climb</b>	<ul style="list-style-type: none"> <li>• 3 preset values or use keypad to input desired feet</li> <li>• Terrain (<i>Flat, Hill Interval, Rolling Hills, Random, Kilimanjaro</i>)</li> <li>• Level (<i>if Hill Interval, Random, Rolling Hills or Kilimanjaro is chosen</i>)</li> <li>• Incline (<i>if Flat is chosen</i>)</li> <li>• Speed</li> <li>• Weight</li> </ul>
<b>Heart Rate</b>	<ul style="list-style-type: none"> <li>• 3 preset values or use keypad to input desired time</li> <li>• Age</li> <li>• Workout (<i>Moderate Burn or Vigorous Burn</i>)</li> <li>• Target Heart Rate</li> <li>• Speed</li> <li>• Weight</li> </ul>
<b>Intervals</b>	<ul style="list-style-type: none"> <li>• Settings (<i>Custom, High Intensity, Endurance</i>)</li> <li>• Time (<i>if Custom is chosen</i>)</li> <li>• Low Speed</li> <li>• High Speed</li> <li>• Weight</li> </ul>

**Symbio Incline Elliptical, Symbio Recumbent Cycle, Symbio Upright LifeCycle, and Symbio Upright SwitchCycle**

Standard Goals	User Input
<b>Time</b>	<ul style="list-style-type: none"> <li>• 3 preset values or use keypad to input desired time</li> <li>• Terrain (<i>Flat, Hill Interval, Rolling Hills, Random, Kilimanjaro</i>)</li> <li>• Level</li> <li>• Weight</li> </ul>
<b>Distance</b>	<ul style="list-style-type: none"> <li>• 3 preset values or use keypad to input desired distance</li> <li>• Terrain (<i>Flat, Hill Interval, Rolling Hills, Random, Kilimanjaro</i>)</li> <li>• Level</li> <li>• Weight</li> </ul>
<b>Calories</b>	<ul style="list-style-type: none"> <li>• 3 preset values or use keypad to input desired calories</li> <li>• Weight</li> <li>• Terrain (<i>Flat, Hill Interval, Rolling Hills, Random, Kilimanjaro</i>)</li> <li>• Level</li> <li>• Weight</li> </ul>
<b>Heart Rate</b>	<ul style="list-style-type: none"> <li>• 3 preset values or use keypad to input desired time</li> <li>• Age</li> <li>• Workout (<i>Moderate Burn or Vigorous Burn</i>)</li> <li>• Level</li> <li>• Weight</li> </ul>
<b>Intervals</b>	<ul style="list-style-type: none"> <li>• Settings (<i>Starter</i>)</li> <li>• Time</li> <li>• Level</li> <li>• Weight</li> </ul>
	<ul style="list-style-type: none"> <li>• Settings (<i>High Intensity, Endurance</i>)</li> <li>• Intervals</li> <li>• Active Level</li> <li>• Recovery Level</li> <li>• Weight</li> </ul>
<b>Constant Power</b>	<ul style="list-style-type: none"> <li>• Time</li> <li>• Watts</li> <li>• Weight</li> </ul>
<b>Adaptive Power</b>	<ul style="list-style-type: none"> <li>• Time</li> <li>• Level</li> <li>• Weight</li> </ul>
<b>Aerobics</b>	<ul style="list-style-type: none"> <li>• Time</li> <li>• Level</li> <li>• Weight</li> </ul>
<b>Reverse</b>	<ul style="list-style-type: none"> <li>• Time</li> <li>• Level</li> <li>• Weight</li> </ul>
<b>METs</b>	<ul style="list-style-type: none"> <li>• Time</li> <li>• METs</li> <li>• Weight</li> </ul>

## User Input Ranges

Time	1 - 60 minutes
Weight	75 - 400 lbs. (34 -181 kg)
Incline	0.0 - 15.0
Speed	0.5 - 14.0 MPH (0.5 - 23 KPH) ( <i>commercial units</i> ) 0.5 - 12.0 MPH (0.5 - 19 KPH) ( <i>home units</i> )
Age	10 - 99 years
Height	36 - 90 inches
Watts	50 - 500
METs	2.5 - 21
Average Level	1 - 20

**Level refers to a range of incline percentages.**

Level	% Incline	Level	% Incline
1	0.0 - 1.5	11	2.0 - 8.5
2	0.0 - 2.2	12	3.0 - 9.2
3	0.0 - 2.9	13	3.5 - 9.9
4	0.0 - 3.6	14	5.0 - 10.6
5	0.0 - 4.3	15	5.5 - 11.3
6	0.0 - 5.0	16	6.5 - 12.0
7	0.0 - 5.7	17	7.0 - 12.7
8	0.0 - 6.4	18	8.0 - 13.4
9	0.5 - 7.1	19	8.7 - 14.1
10	1.5 - 7.8	20	9.0 - 15.0

## Theoretical Maximum Heart Rates and Target Heart Rates

Reference the chart below for Theoretical Maximum Heart Rates and Target Heart Rates. Listed as BPM (Beats per Minute).

Age	Theoretical Maximum Heart Rate	65% (Moderate Burn)	80% (Vigorous Burn)
10	200	130	160
20	194	126	155
30	187	121	149
40	180	117	144
50	173	113	139
60	167	108	133
70	160	104	128
80	153	100	123
90	147	95	117
99	141	91	112

Wear the optional Polar® telemetry heart rate chest strap, or grip the Lifepulse™ sensors, to enable the on-board computer to monitor the heart rate during a workout. The computer automatically adjusts the incline level (Treadmills only) to maintain the target heart rate based on the actual heart rate.

## Symbio Recumbent Cycle Settings

1. Sit on the seat and place the balls of the feet on the pedals.

**NOTE:** An optimum position allows movement through the bottom of the stroke without locking the knees or shifting in the seat. The knees should have a slight bend at the point of fullest leg extension.

2. Lift the seat adjustment bar located underneath the seat.
3. Hold the seat adjustment bar with one hand and use the other hand to grab the rear of the seat.



**CAUTION:** Do not attempt to adjust the seat while pedaling the bike. Doing so may cause injury or result in an uncomfortable workout.

4. Slide the seat forward and backward as necessary to the proper position. Release the seat adjustment bar to complete engagement.

**NOTE:** The console will display information and adjustments for **Recline**, **Seat Adjustment**, and **Proper Form**. The **Seat Adjustment** setting will be saved for logged-in users.



5. Gently slide the seat forward and backward a small distance to ensure it is locked into place.
6. Tap the highlighted + symbol for **Seat Adjustment**. The **Seat Adjustment** information screen will be displayed.

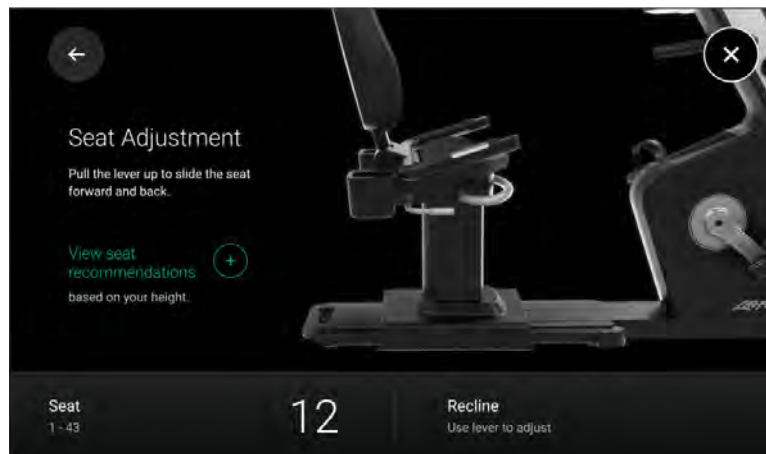

7. Tap the highlighted + symbol for **View seat recommendations**.  
The **Seat Recommendations** information screen will be displayed.

User Height, Imperial

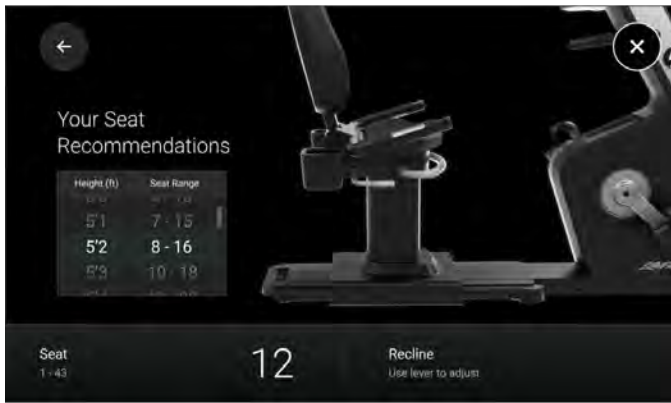

User Height, Metric



8. Tap the **Back arrow** to return to the **Seat Adjustment** screen.  
9. Check the seat distance and readjust as necessary.  
10. Tap the **Back arrow** to return to the adjustment and information screen.  
11. Tap the highlighted + symbol for **Proper Form**.  
The **Proper Form** information screen will be displayed.

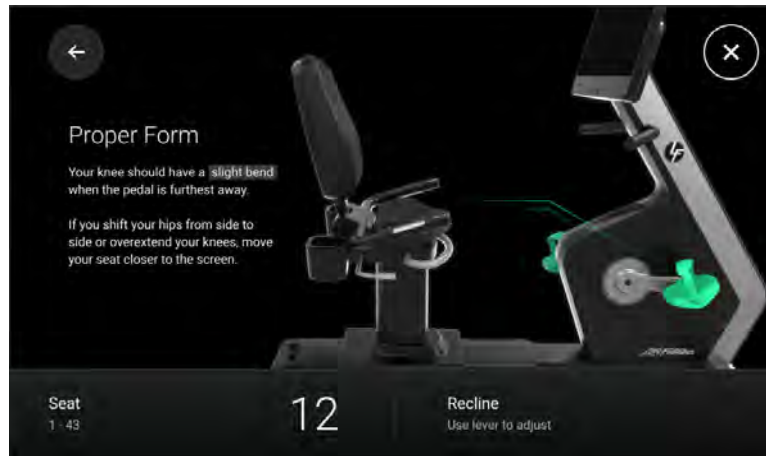

12. Tap the **Back arrow** to return to the adjustment and information screen.  
13. Tap the highlighted + symbol for **Recline**.  
The **Recline** information screen will be displayed.



14. Sit on the seat, then lift the recline handle and hold.

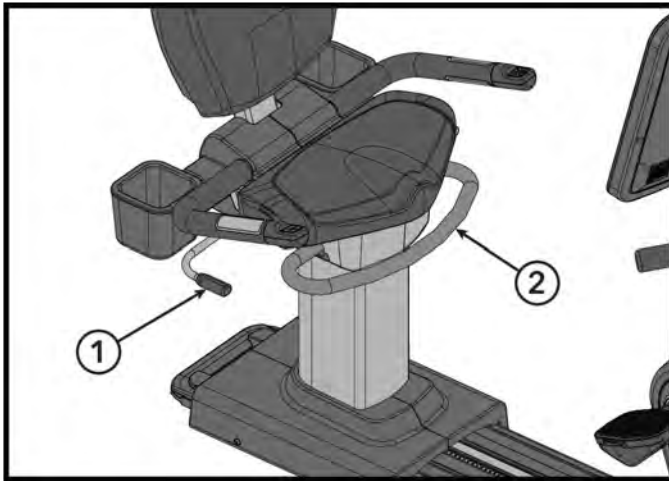

Item	Description	Qty.
1	Recline Handle	1
2	Seat Adjustment Bar	1

15. Push back on the upper seat pad to the desired position.

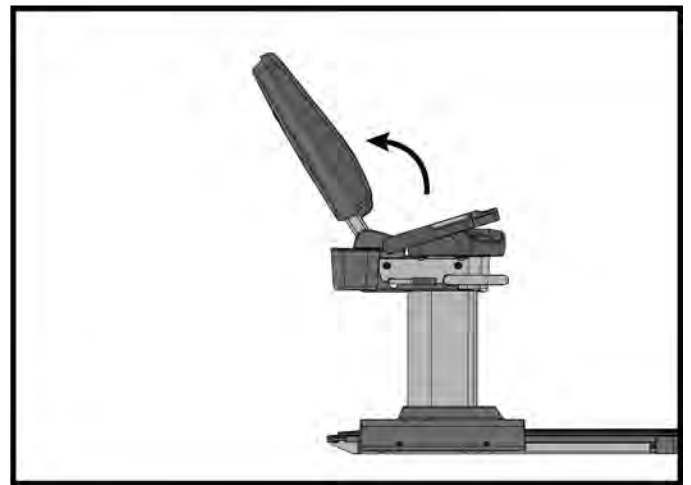
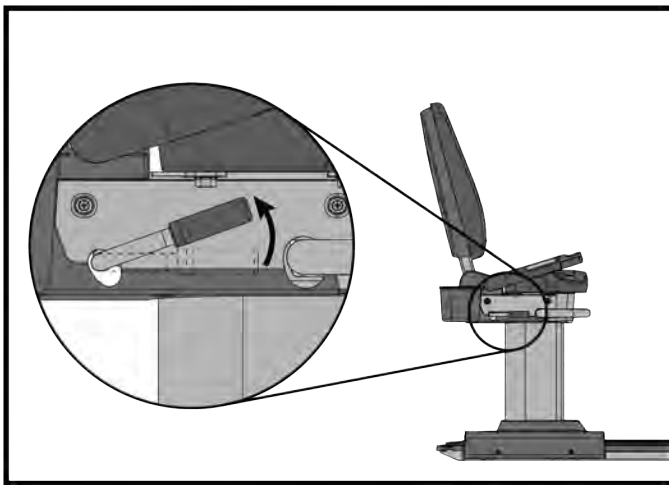

16. Release the recline handle to complete engagement.

17. Tap the **Back arrow** to return to the adjustment and information screen.

18. Tap **X** icon to exit **Proper Form** screen.

19. Tap **X** icon to exit recumbent bike settings screen.

## Upright LifeCycle and SwitchCycle Settings

1. Sit on the seat and place the balls of the feet on the pedals.

**NOTE:** An optimum position allows movement through the bottom of the stroke without locking the knees, shifting in the seat or forcefully extending the hips. The knees should have a slight bend at the point of fullest leg extension.

2. If the seat needs to be adjusted lower, lift the spring-loaded adjusting handle located underneath the nose of the seat.



**CAUTION:** Do not attempt to adjust the seat while pedaling the bike or sitting on the seat. Doing so may cause injury or result in an uncomfortable workout.

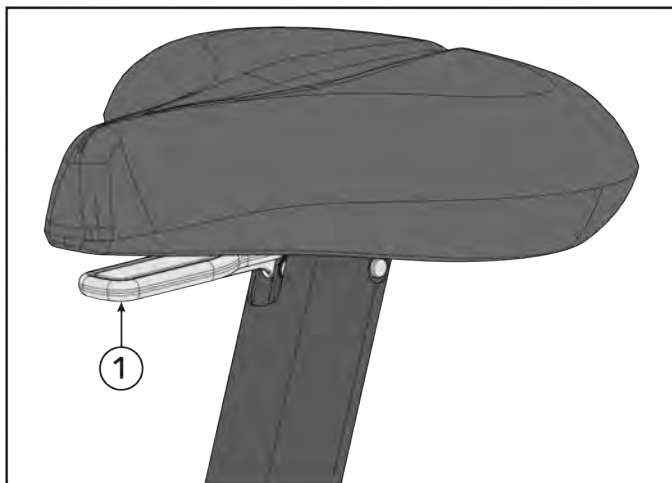

Item	Description	Qty.
1	Seat Adjustment Handle	1

3. Hold both the handle and nose of the seat with one hand and use the other hand to grab the rear of the seat.
4. Slide the handle and seat down to the proper position. Release the handle to complete engagement.

**NOTE:** The console will display information and adjustments for **Seat Height Adjustment**, **Handlebar Adjustment**, and **Proper Form**. The **Seat Height Adjustment** and **Handlebar Adjustment** settings will be saved for logged-in users.

### Upright LifeCycle



### Upright SwitchCycle



5. Gently slide the seat up and down a small distance to ensure it is locked into place.

6. Tap the highlighted + symbol for **Seat Height Adjustment**.  
The **Seat Height Adjustment** information screen will be displayed.

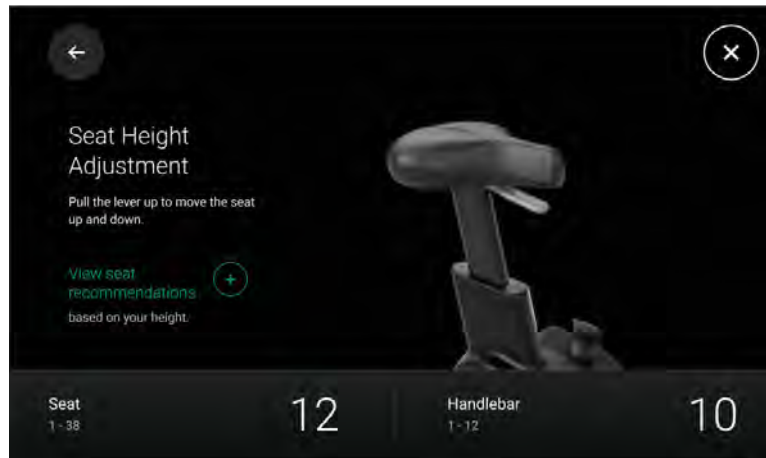

7. Tap the highlighted + symbol for **View seat recommendations**.  
The **Seat Recommendations** information screen will be displayed.

User Height, Imperial



User Height, Metric



8. Tap the **Back arrow** to return to the **Seat Adjustment** screen.
9. Check the seat distance and readjust as necessary.
10. If the seat needs to be adjusted higher, grab the seat and slide it up to the proper position. When adjusting the seat to a higher position, the user does not have to lift the adjusting handle.
11. Tap the **Back arrow** to return to the adjustment and information screen.
12. Tap the highlighted + symbol for **Handlebar Adjustment**.  
The **Handlebar Adjustment** information screen will be displayed.

Upright LifeCycle

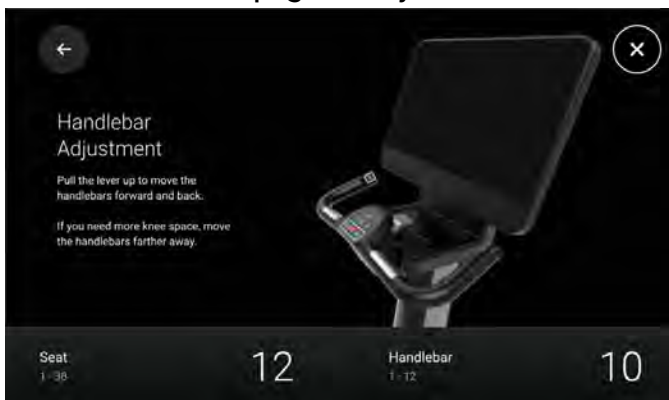

Upright SwitchCycle



13. Lift the handlebar adjust handle and hold.
14. Slide the handlebar to the proper position. Release the handle to complete engagement.

**NOTE:** The console will display the handlebar position number and will be saved for logged in users.

15. Tap the **Back arrow** to return to the adjustment and information screen.

16. Tap the highlighted **+** symbol for **Proper Form**.

The **Proper Form** information screen will be displayed.



17. Tap **X** icon to exit **Proper Form** screen.

18. Tap **X** icon to exit recumbent bike settings screen.

## Quick Start

Users have two ways to select a **Quick Start** workout.

- Press the **Quick Start** button on the **Home** Screen.

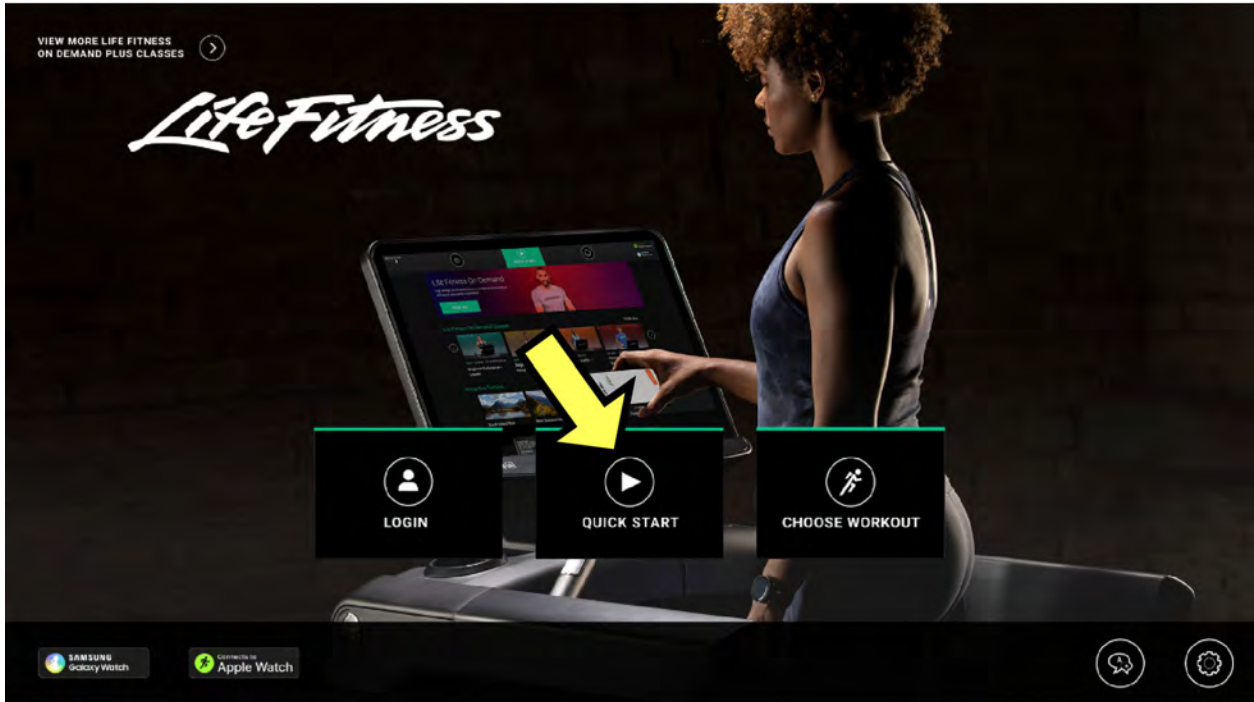

- Press the **Quick Start** button at the top of the **Choose Workout** screen.

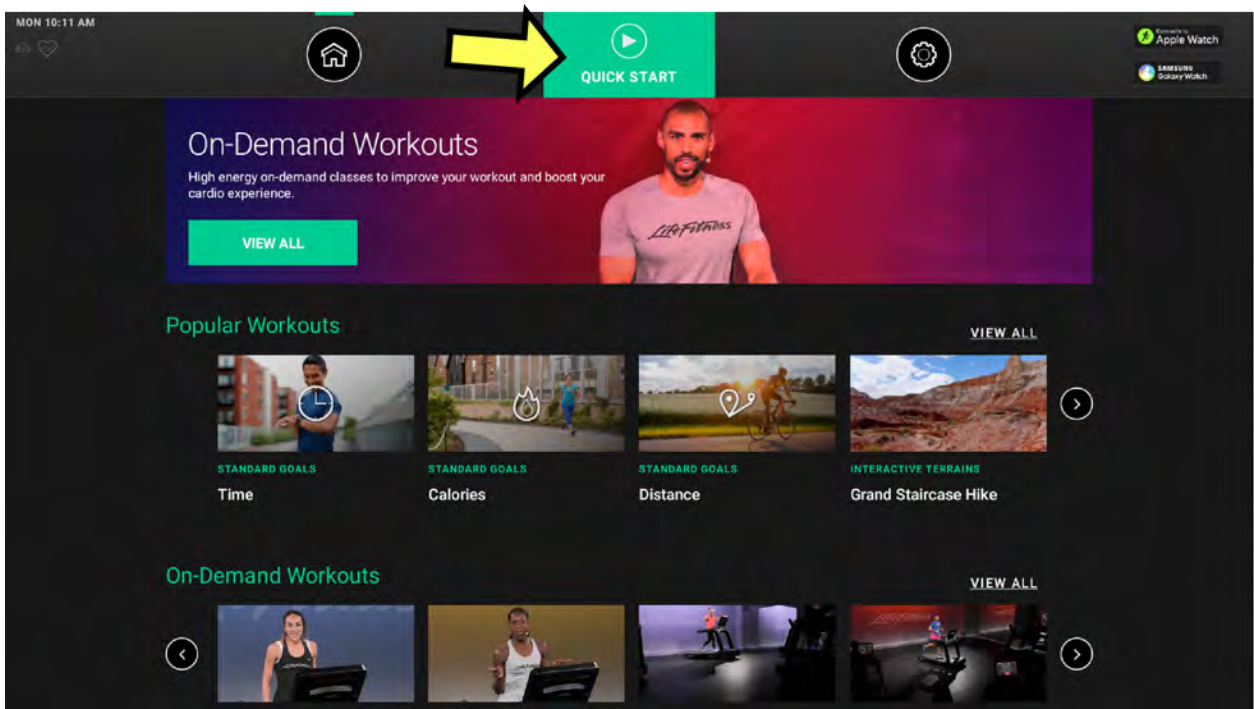

- A workout countdown 3, 2, 1 screen appears.
- Users can make adjustments to the workout after starting a workout.
- **NOTE: Treadmill:** A Quick Start workout begins at a speed of 0.5 Miles Per Hour (MPH) / 0.8 Kilometers Per Hour (KPH) and an incline of 0.0%.

# LFOD+™

Life Fitness On Demand+ complimentary software includes On-Demand instructor-led workouts and Streaming Interactive Terrains workouts.

- **On-Demand Workouts:** Choose from over 400 motivational, instructor-led classes ranging in length from 10 to 40 minutes, available on Life Fitness treadmills, Cross-Trainers, upright bikes, and recumbent bikes. Classes vary in difficulty and are led by the best instructors around the globe to get your exercisers results. Available in English, Spanish, German, French, Japanese and Russian. The classes are streamed through the internet. Software updates are not required in order to view new classes.
- **Streaming Interactive Terrains:** Choose from 100+ runs and rides through stunning scenery around the world. Incline and resistance adjust to the terrain for an immersive experience that allows exercisers to work out at higher intensities and lose track of time.

**NOTE:** A small selection of Interactive Terrain workouts are available on the console that don't require internet access.

**NOTE:** Life Fitness On Demand+ can be enabled through [Halo.Fitness](#) or [Access Systems Options](#).

The settings for On-Demand Workouts and Streaming Interactive Terrains must be **Enabled / Turned On** in Manager's Configuration to access the **full** library of streaming workouts.

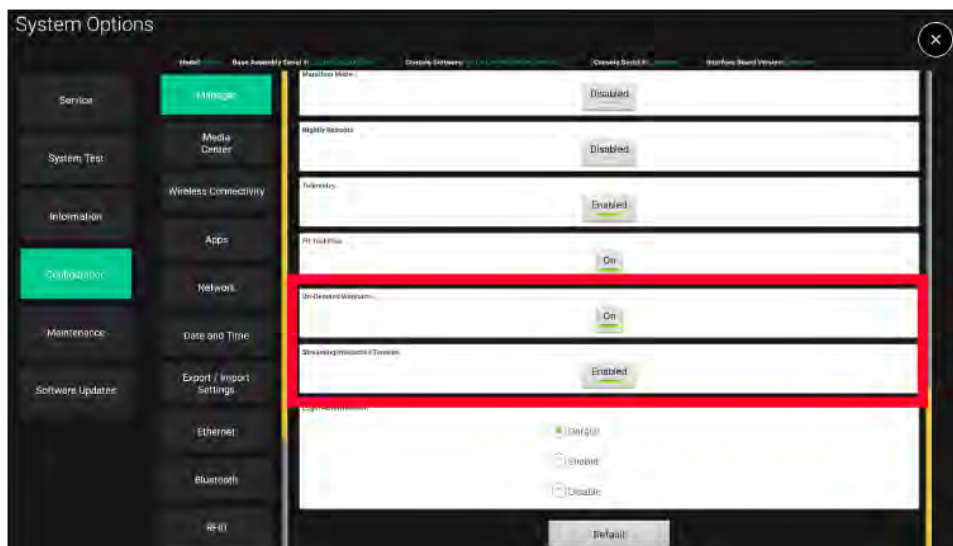

## Internet Bandwidth Requirements

Life Fitness On Demand+ requires a strong internet connection for optimal user experience. **At least 2.5 Mbps per machine is recommended.**

Internet bandwidth, otherwise known as your network connection speed, is measured in Megabits per second (Mbps). To find out what your facility bandwidth is, we recommend free online websites like [speedtest.net](http://speedtest.net) or [fast.com](http://fast.com). Simply open one of these websites on a device with a browser that is connected to your wired internet or WiFi network. The website will show you a measure of your connection speed in Mbps, then compare it to the table below.

## Minimum Download Bandwidth Requirements

Services	Up to 8 Units	Each Additional Unit
Asset management, remote software updates, and user workout tracking	2.5 Mbps	0.25 Mbps
Above services and web browsing access	4 Mbps	0.25 Mbps
Above services and web video, e.g. YouTube	4 Mbps	0.5 Mbps
Above services and video streaming apps, e.g. Netflix	8 Mbps	1.0 Mbps
<b>Above services and Life Fitness On Demand+ workouts</b>	<b>20 Mbps</b>	<b>2.5 Mbps</b>

If your facility has low bandwidth we recommend that you enable Life Fitness On Demand+ only on a select number of units. You may experience lagging internet connectivity if you do not have the appropriate bandwidth. Use this chart as a guide:

<b>Bandwidth in Mbps</b>	<b>Recommended Number of Units Enabled</b>
20	8
40	16
60	24
80	32
100	40

## On-Demand Workouts

The following conditions must be met for the On-Demand workouts video library to appear:

- On-Demand Workouts must be enabled on the unit. Enable on [Halo.Fitness](#) or in [Access Systems Options](#).
- The unit must be connected to the internet.
- The unit must be updated with software version 4.10 or later.

### Selecting and Using a Video

1. Access On-Demand Workouts via these options:

- **Home Screen:** Press **View More Life Fitness On Demand Classes**.

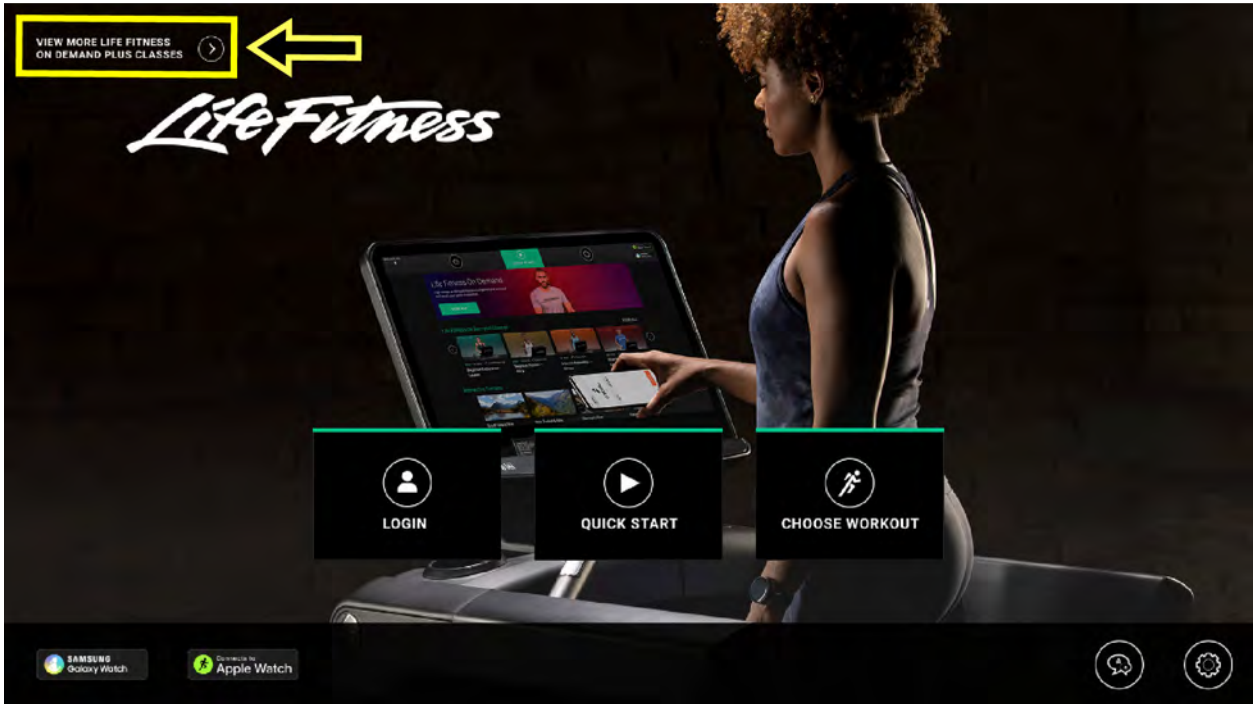

• **Choose Workout Screen:**

- Scroll to the **On-Demand Workout** category and press **View All** to view complete On-Demand Workouts library.
- Scroll to **Popular Workouts** and choose a video.

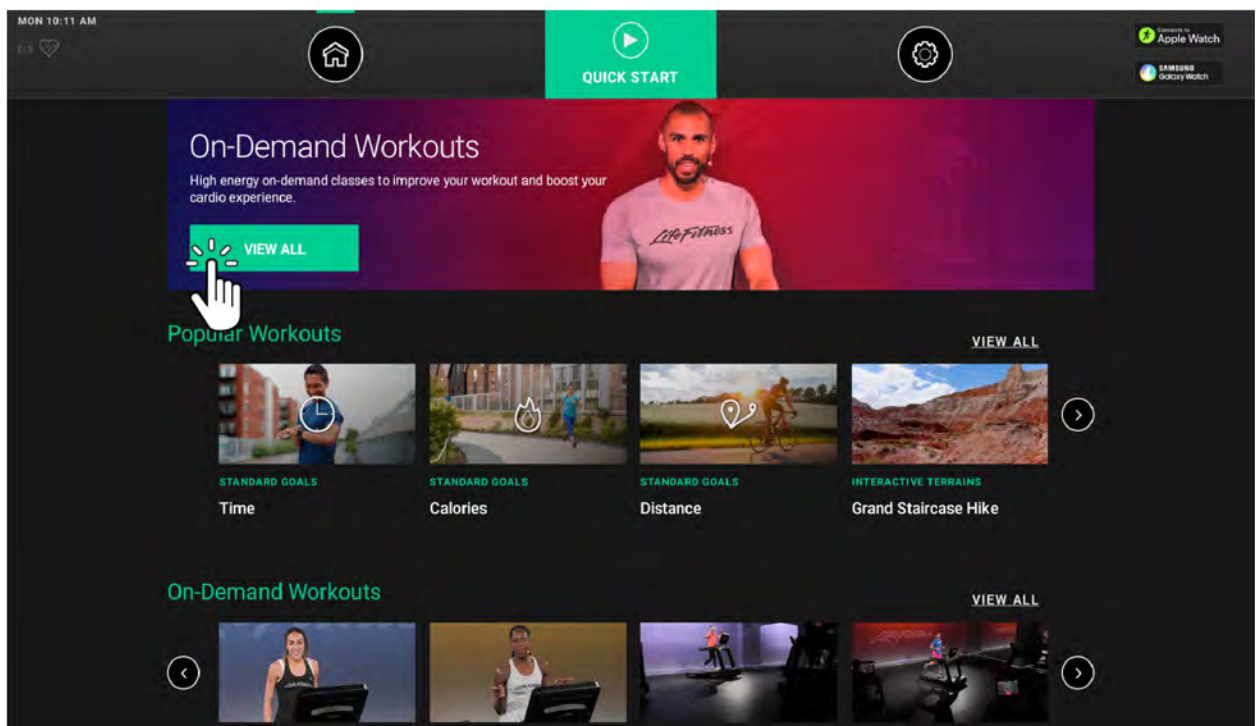

2. The On-Demand Workouts library allows users to filter workouts by the following categories:

- Language
- Duration
- Difficulty
- Instructor

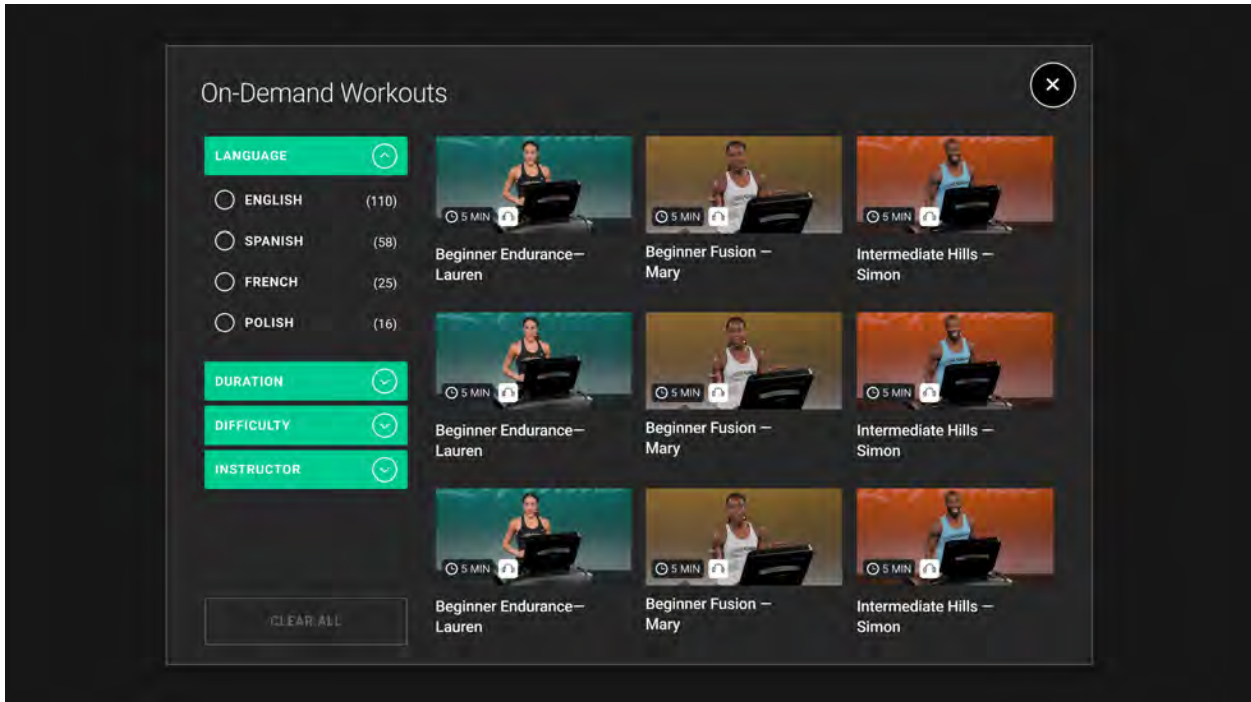

3. Tap on an On-Demand Workout tile to display more details about the selected class. Exercisers can pair their Bluetooth headphones by tapping **Connect Headphones** and following the prompts. Press **Start Workout**.

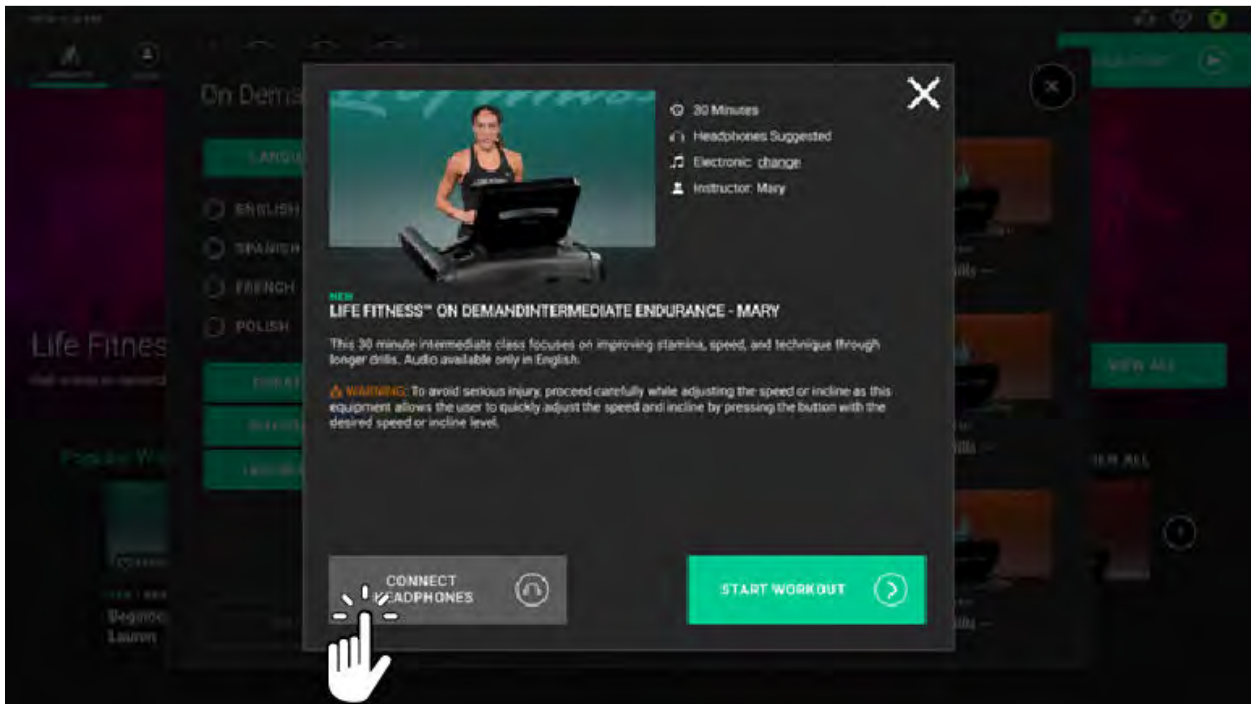

4. Use the quick-touch buttons to adjust workout settings such as speed, incline and resistance.

**NOTE:** Quick-touch buttons vary depending on workout. Image shown is a treadmill workout.

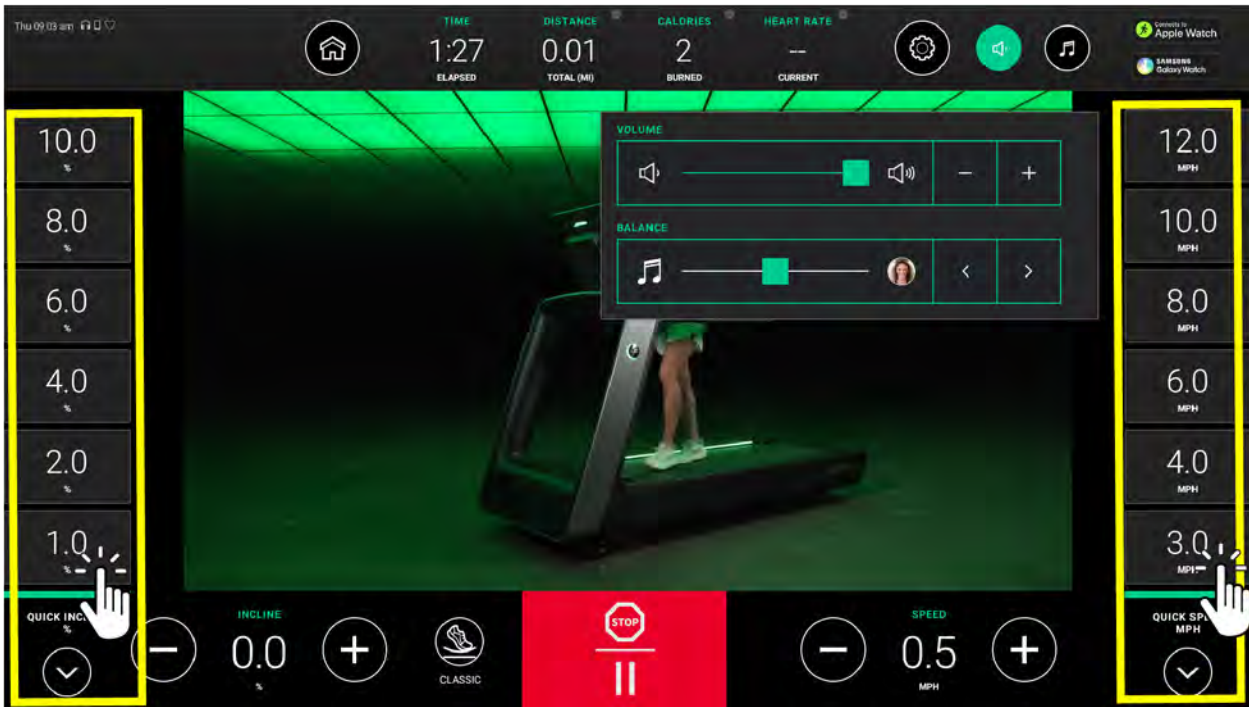

For Symbio Runner, speed settings can also be adjusted using the control pad.

#### On Demand course speed settings in control pad

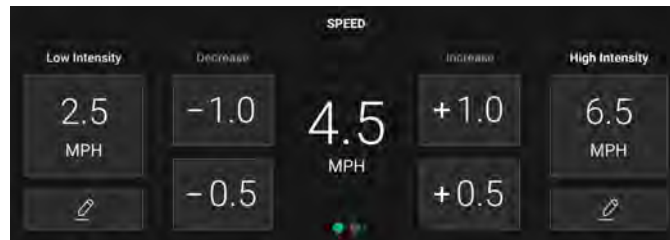

5. Press the **Music Note** to access volume options for the song playing and the music / instructor balance.

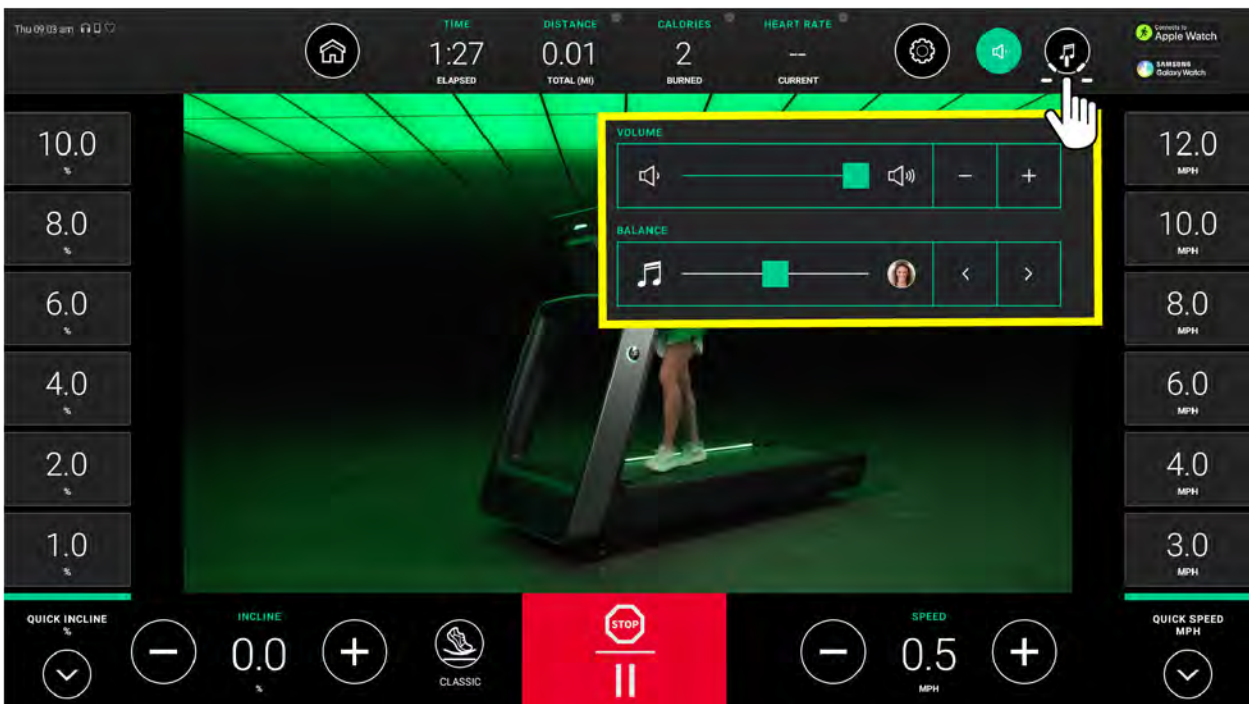

## Interactive Terrains

The Interactive Terrains are video courses, shot in first person perspective through landscapes, cityscapes, and events from around the world. This feature interacts with the fitness equipment to provide an immersive experience.

**NOTE:** The incline of the treadmill automatically increases or decreases to correspond with the virtual hills on the course.

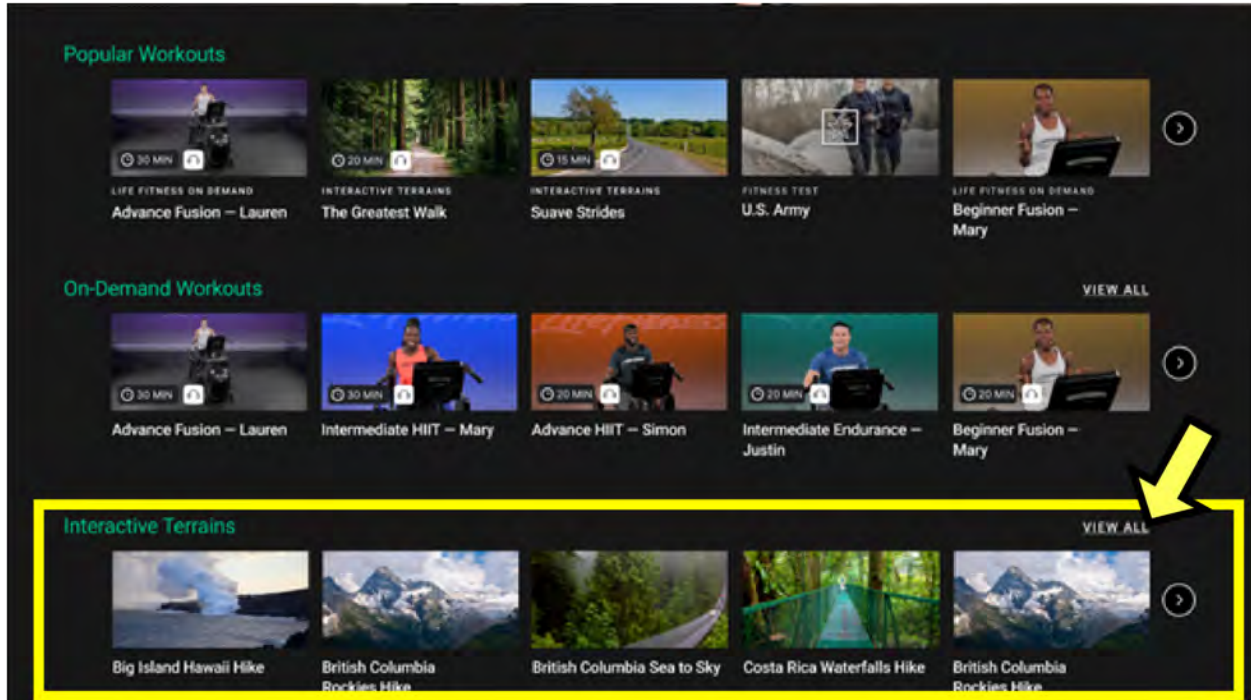

Press **VIEW ALL** to access the Interactive Terrains workout library and choose desired course.

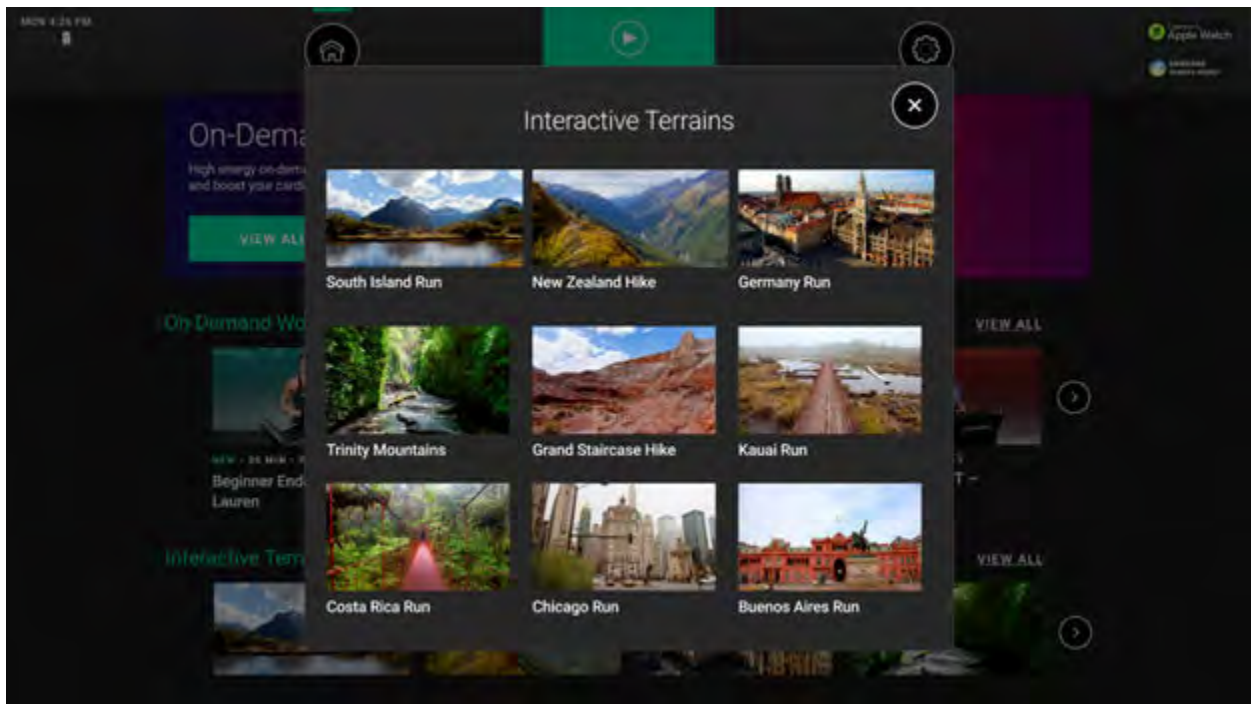

**NOTE:** Life Fitness On Demand+ can be enabled through [Halo.Fitness](#) or [Access Systems Options](#).

A small selection of Interactive Terrain workouts are available on the console that don't require internet access. The setting for Streaming Interactive Terrains must be **Enabled** in Manager's Configuration to access the **full** library of streaming workouts.

## Standard Goals

Choose desired goal.

**NOTE:** Available Goal Workouts vary by base type.

**NOTE:** Reference [Workouts List](#), [Workout Descriptions](#) and [Workout Setup - Data Inputs](#).

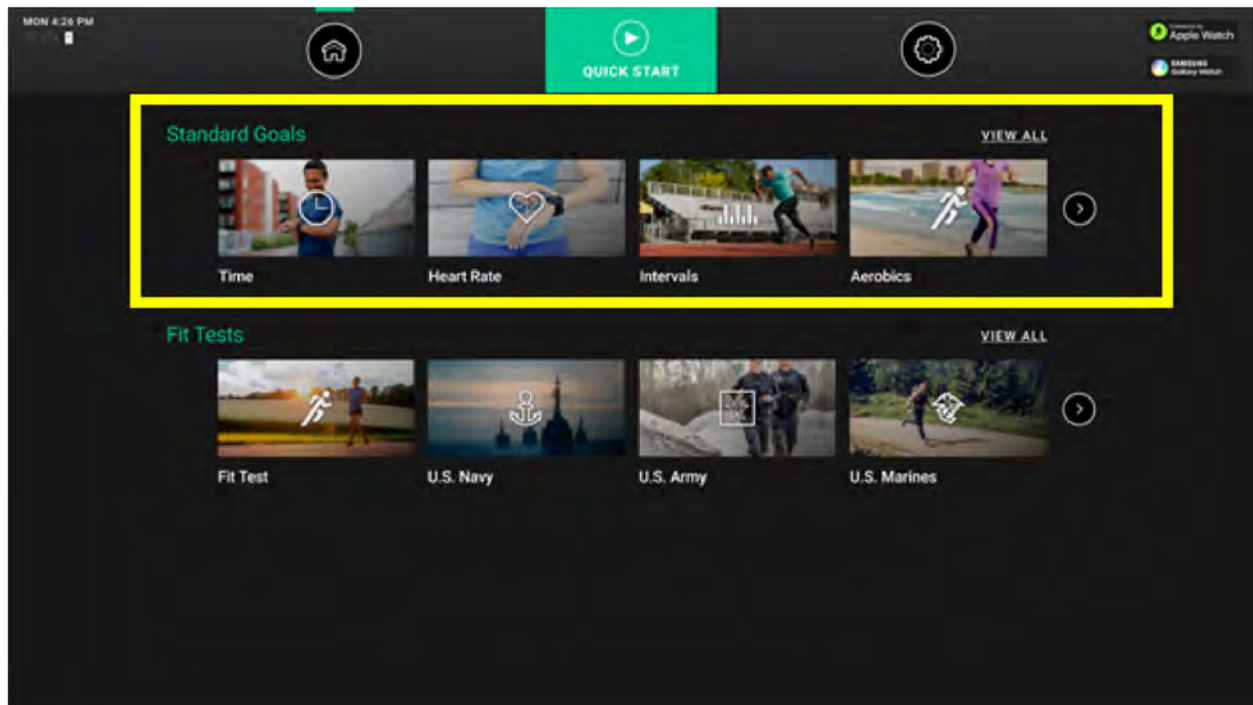

## Fit Tests

Choose desired fit test.

**NOTE:** Available fit test workouts vary depending on base type.

**NOTE:** Reference [Workouts List](#), [Workout Descriptions](#) and [Workout Setup - Data Inputs](#).

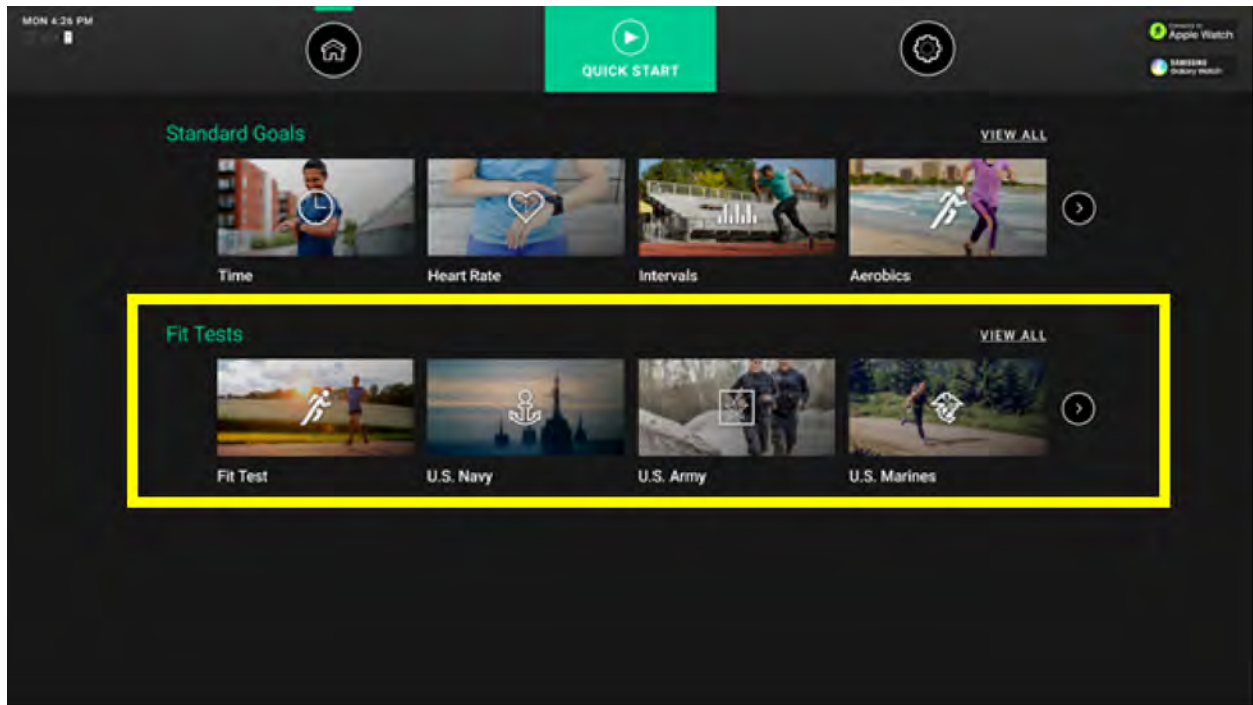

## Life Fitness Fit Test

- The Life Fitness Fit Test estimates cardiovascular activity and can be used to monitor improvements in endurance every 4 - 6 weeks.
- The Fit Test is considered to be a submax  $VO_2$  (volume of oxygen) test and gauges how well the heart supplies oxygenated blood to the exercising muscles and how efficiently those muscles receive oxygen from the blood.
- Physicians and exercise physiologists generally regard this test as a good measure of aerobic capacity.
- Workout duration is 5 minutes total.
- Take the Fit Test under similar circumstances each time. For the most accurate Fit Test results, you should perform the Fit Test on three consecutive days and average the three scores.
- To receive a proper Fit Test score, the work done must be within a training heart rate zone that is 60% to 85% of the theoretical maximum heart rate (HRmax).

The user must grasp the hand sensors when prompted, or wear a Polar telemetry heart rate chest strap as the test score calculation is based on a heart rate reading.

**NOTE:** The workout will be terminated if a heart rate is not detected after 2.5 minutes.

Your heart rate is dependent on many factors, including:

- amount of sleep the previous night (at least 7 hours is recommended)
- time of day
- time you last ate (2 - 4 hours after the last meal is recommended)
- time since you last drank a liquid containing caffeine or alcohol, or smoked a cigarette (at least 4 hours is recommended)
- time since you last exercised (at least 6 hours is recommended)

Suggested exertion levels should be used as a guideline for setting up the Fit Test program. The goal is to elevate the user's heart rate to a level that is between 60%-85% of their theoretical maximum heart rate.

	Inactive	Active	Very Active
<b>Treadmill</b>	2 - 3 mph (3.2 - 4.8 kph)	3 - 4 mph (4.8 - 6.4 kph)	3.5 - 4.5 mph (5.6 - 7.2 kph)
<b>Cross-Trainer</b>	L 2-4 men L 1-2 women	L 3-10 men L 2-5 women	L 7-15 men L 3-10 women
<b>LifeCycle Exercise Bikes</b>	L 4-6 men L 2-4 women	L 5-10 men L 3-7 women	L 8-14 men L 6-10 women

Within each suggested range, use these additional guidelines:

Lower Half of Range	Upper Half of Range
higher age	lower age
lower weight	higher weight (in cases of excessive weight, use lower half of range)
shorter	taller

After the 5-minute FIT TEST is completed, a FIT TEST score and rating will be displayed.

Please note that the estimated  $VO_2$  max scores achieved will be 10-15% lower on stationary exercise bikes than those achieved on other Life Fitness cardiovascular equipment. Stationary cycling has a higher rate of isolated muscle fatigue of the quadriceps when compared to walking / running on a treadmill or utilizing a bike. This higher rate of fatigue corresponds to lower levels of estimated  $VO_2$  max scores.

### Relative Fitness Classification for MEN

Rating	Elite	Excellent	Very Good	Above Average	Average	Below Average	Low	Very Low
Estimated $VO_2$ Max (ml/kg/min) per Age category								

Rating	Elite	Excellent	Very Good	Above Average	Average	Below Average	Low	Very Low
20 - 29 years	55+	53 - 54	50 - 52	45 - 49	40 - 44	38 - 39	35 - 37	<35
30 - 39 years	52+	50 - 51	48 - 49	43 - 47	38 - 42	36 - 37	34 - 35	<34
40 - 49 years	51+	49 - 50	46 - 48	42 - 45	37 - 41	34 - 36	32 - 33	<32
50 - 59 years	47+	45 - 46	43 - 44	39 - 42	34 - 38	32 - 33	29 - 31	<29
60+ years	43+	41 - 42	39 - 40	35 - 38	31 - 34	29 - 30	26 - 28	<26

**Relative Fitness Classification for WOMEN**

Rating	Elite	Excellent	Very Good	Above Average	Average	Below Average	Low	Very Low
Estimated VO <sub>2</sub> Max (ml/kg/min) per Age category								
20 - 29 years	47+	45 - 46	43 - 44	38 - 42	33 - 37	31 - 32	28 - 30	<28
30 - 39 years	44+	42 - 43	40 - 41	36 - 39	31 - 35	29 - 30	27 - 28	<27
40 - 49 years	42+	40 - 41	38 - 39	34 - 37	30 - 33	28 - 29	25 - 27	<25
50 - 59 years	37+	35 - 36	33 - 34	30 - 32	26 - 29	24 - 25	22 - 23	<22
60+ years	35+	33 - 34	31 - 32	27 - 30	24 - 26	22 - 23	20 - 21	<20

Life Fitness developed this rating scale based on VO<sub>2</sub> max percentile distributions referenced in American College of Sports Medicine's Guidelines for Exercise Testing and Prescription (8th E. 2010). It is designed to provide a qualitative description of a user's VO<sub>2</sub> max estimation, and a means of assessing initial fitness level and tracking improvement.

## 6. Maintenance and Troubleshooting

**NOTE:** Safety of the equipment can be maintained only if the equipment is examined regularly for damage or wear. Keep the equipment out of use until defective parts are repaired or replaced.

**NOTE:** Pour assurer la sécurité du matériel, il convient de l'inspecter régulièrement afin de déceler tout signe d'usure ou d'endommagement. N'utilisez pas l'appareil avant d'avoir réparé ou remplacé les pièces défectueuses.

The following preventive maintenance tips will keep the product operating at peak performance:

- Locate the product in a cool, dry place.
- Clean the display console and all exterior surfaces with an approved or compatible cleaner (see Approved and Compatible Cleaners) and a microfiber cloth.
- Long fingernails may damage or scratch the surface of the console; use the pad of the finger to press the selection buttons on the console.

### Approved and Compatible Cleaners

Two preferred cleaners have been approved by reliability experts: PureGreen 24 and Gym Wipes. Both cleaners will safely and effectively remove dirt, grime and sweat from equipment. PureGreen 24 and the Antibacterial Force formula of Gym Wipes are both disinfectants that are effective against MRSA and H1N1.

PureGreen 24 is available in a spray which is convenient for gym staff to use. Apply the spray to a microfiber cloth and wipe down the equipment. Use PureGreen 24 on the equipment for at least 2 minutes for general disinfection purposes and at least 10 minutes for fungus and viral control.

Gym Wipes are large, durable pre-moistened wipes to use on the equipment before and after workouts. Use Gym Wipes on the equipment for at least 2 minutes for general disinfection purposes.

Contact Customer Support Services to order these cleaners (1-800-351-3737 or email: [customersupport@lifefitness.com](mailto:customersupport@lifefitness.com)).

Mild soap and water or a mild non-abrasive household cleaner can also be used to clean the display and all exterior surfaces. Use a soft microfiber cloth only. Apply the cleaner to the microfiber cloth before cleaning. DO NOT use ammonia or acid based cleaners. DO NOT use abrasive cleaners. DO NOT use paper towels. DO NOT apply cleaners directly to the equipment surfaces.

### Troubleshooting

#### Knowledge Base

See <https://lfn.fit/KnowledgeBase> for more detailed information.

## Troubleshooting - Smart Lighting

The base is equipped with lighting that can be tuned On or Off, has three brightness setting, and 16 colors.

1. Select **Language** icon from Attract Screen to access the **Select Language** screen.

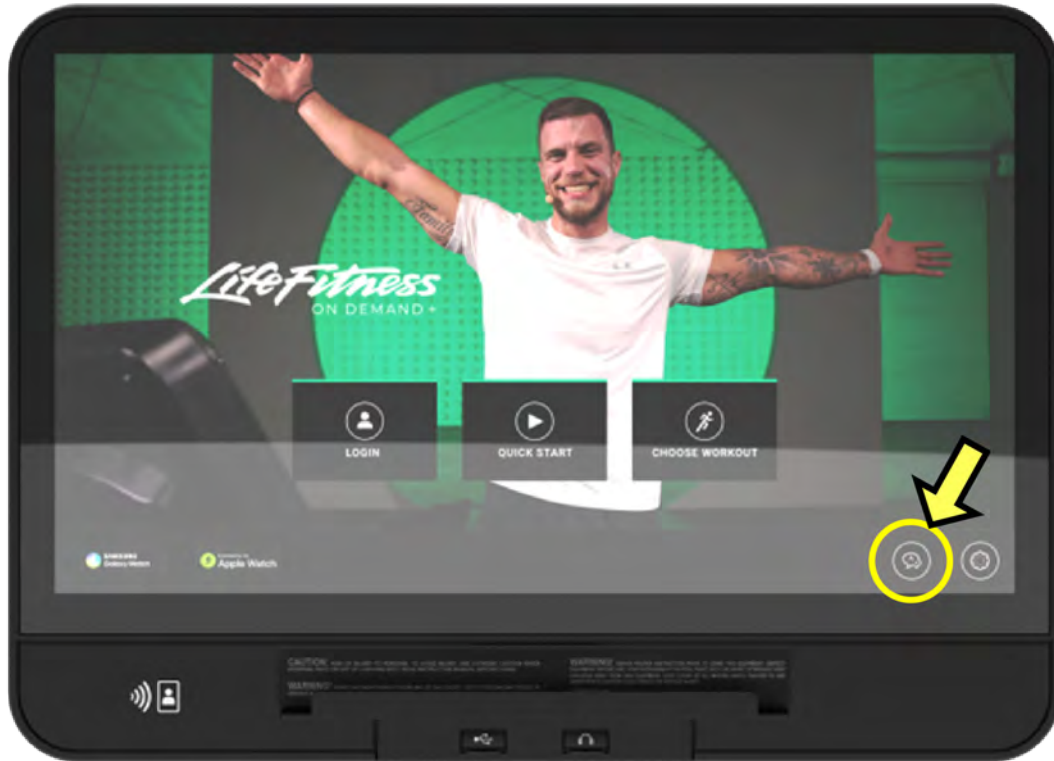

2. Tap the bottom part of the **Select Language** screen in the following sequence: **Lower-Left, Lower-Right, Lower-Left, Lower-Right**.

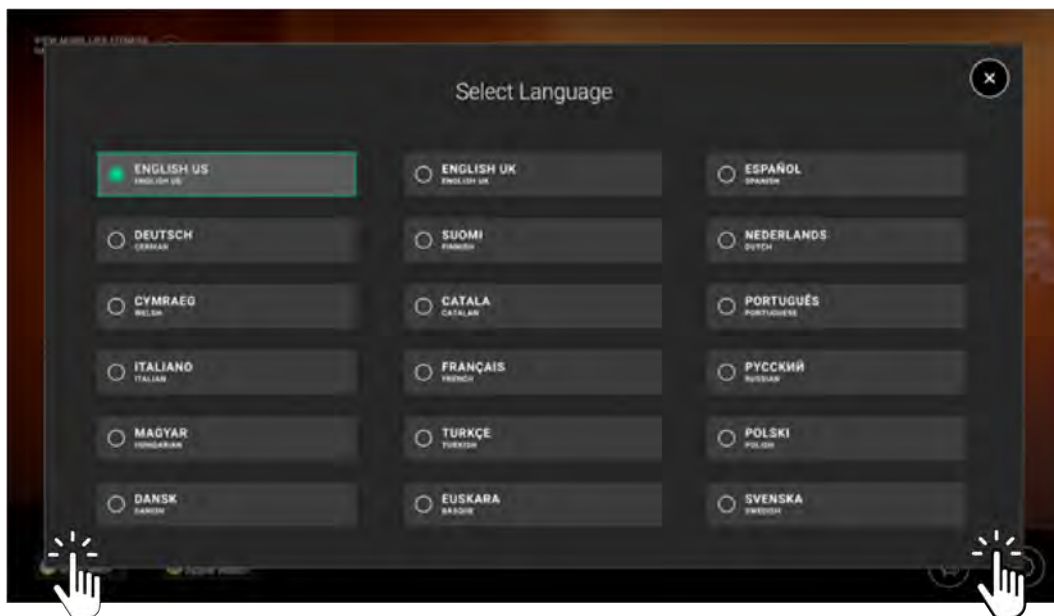

**NOTE:** Make sure you tap INSIDE the black square!

3. Navigate through the System Options menu to **Configuration > Manager**.

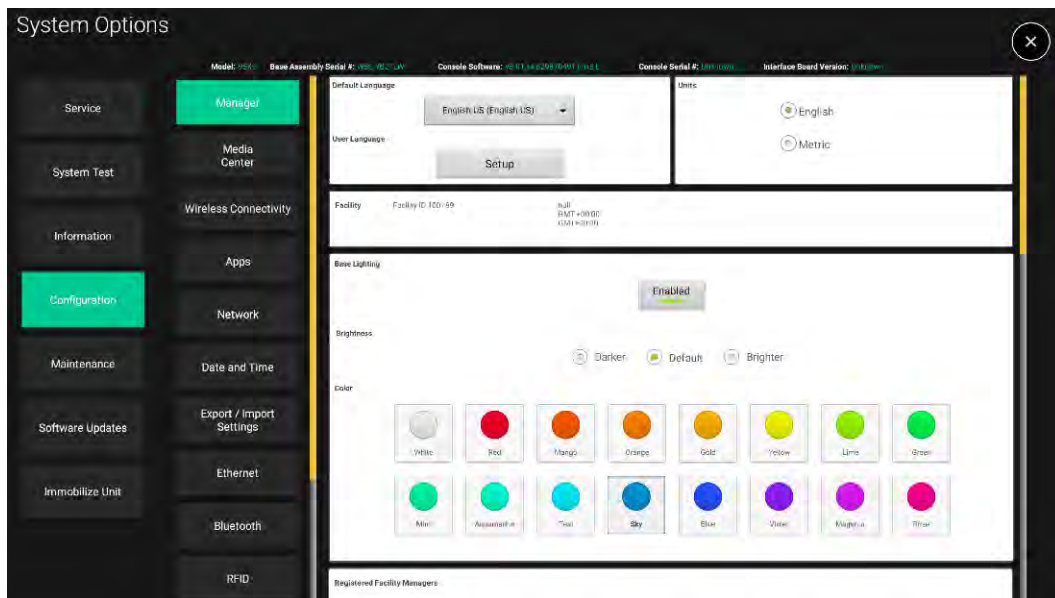

4. Scroll down to **Smart Lighting**.
5. Toggle the **Enabled** button to ensure the lights are turned on.
6. Adjust the **Brightness** setting to test visibility.
7. Adjust the **Color** to test the light color options.

## Troubleshooting - Heart Rate Reading

Malfunction	Probable Cause	Corrective Action
Heart rate reading is initially detected and functioning normally but then is lost.	Use of personal electronic devices, such as cell phones and portable MP3 players, causes external noise interference.	Remove the source of noise or reposition the exercise equipment.
	Equipment is in close proximity to other sources of noise such as audio/video equipment, fans, two way radios, and high voltage/ high current power lines.	
Heart rate readings are abnormally elevated.	Television sets and/or antennas, cell phones, computers, cars, high voltage power lines, motor driven exercise equipment , and another heart rate transmitter within 3 ft. (0.9 m) generate electromagnetic interference.	Move the product a few inches away from the probable cause, or move the probable cause a few inches away from the product, until the heart rate readings are accurate.
Heart rate reading is erratic or absent entirely.	Belt transmitter electrodes are not wet enough to pick up accurate heart rate readings.	Wet the belt transmitter electrodes (see <a href="#">The Optional Polar Telemetry Heart Rate Chest Strap</a> ).
	Belt transmitter electrodes are not laying flat against the skin.	Ensure the belt transmitter electrodes are laying flat against the skin (see <a href="#">The Optional Polar Telemetry Heart Rate Chest Strap</a> ).
	Belt transmitter needs cleaning.	Wash the belt transmitter with mild soap and water.
	Belt transmitter is not within 3 ft. (0.9 m) of the heart rate receiver.	Make sure the chest strap transmitter is within 3 ft. (0.9 m) of the heart rate receiver.
	Polar telemetry heart rate chest strap battery is depleted.	Contact Life Fitness Customer Support Services for instructions on how to have the Polar telemetry heart rate chest strap replaced.
	Polar telemetry heart rate chest strap did not lock in with the heart rate receiver.	<p>Make sure the Polar telemetry heart rate chest strap is properly attached to the user's chest and move closer to the heart rate receiver inside the console. Wait up to 10 seconds for the heart rate to display on the console. The overall range of the heart rate strap is approximately 3 ft. (0.9 m) after it communicates with the receiver. The strap must be 1.5 - 2 ft. (0.5 - 0.6 m) away from the receiver in order to start communicating. When the display shows a heart rate value stay within 3 ft. (0.9 m).</p> <p>Notes:</p> <ol style="list-style-type: none"> <li>1. Ensure proper adherence of the Polar telemetry heart rate chest strap to user's chest.</li> <li>2. Ensure proper conductivity between the electrodes and user's chest.</li> <li>3. If needed, use the Polar watch to verify chest strap's operation.</li> </ol>

## Troubleshooting - Life Fitness On Demand+

Malfunction	Probable Cause	Corrective Action
On-Demand Workouts / Streaming Interactive Terrains library is not displaying.	On-Demand Workouts / Streaming Interactive Terrains has not been activated.	Activate On-Demand Workouts / Streaming Interactive Terrains via Manager's Configuration or on <a href="#">Halo.Fitness</a> .
	Equipment is not connected to the internet.	Check network connectivity in Manager's Configuration. Use network speed test on console to verify that your facility has 2.5 Mbps of bandwidth per unit.
On-Demand Workouts / Streaming Interactive Terrains videos are lagging or choppy.	Insufficient internet bandwidth.	Disable On-Demand Workouts / Streaming Interactive Terrains on select number of units to reduce bandwidth strain. Refer to <a href="#">Minimum Download Bandwidth Requirements</a> for specifications.
	Unit requires reboot.	Restart the unit. For optimal functioning, enable Nightly Reboots in Manager's Configuration.
Poor audio quality.	Weak wired headphone connection.	If using wired headphones, ensure proper connectivity within headphone jack. Small adjustments in jack placement should produce crisp and clear audio.
	Bluetooth pairing malfunction.	Unpair and repair Bluetooth headphones with the console. Follow the prompts on screen.

## Troubleshooting - Wireless Charger

A blue LED indicator is located on the front of the wireless charger rack. Reference the table below for description and LED indicator status.

Status	Description	LED Indicator	
Start Up	Console is powered ON.	ON	
Standby	Charger is waiting for a device to be placed on.	OFF	
Charging	Charger is currently charging a correctly placed device.	ON	
Charge Complete	Charger completed charging a device.	ON	
Charging Error	<p>Possible Errors:</p> <ol style="list-style-type: none"> <li>1. A foreign object (RFID card, magnets, metal objects, etc.) is detected on the charger coils.</li> <li>2. The phone case is too thick.</li> <li>3. Wireless charger is damaged.</li> </ol>	<p>Corrective Actions:</p> <ol style="list-style-type: none"> <li>1. Remove foreign object from wireless charger. Reposition your phone.</li> <li>2. Remove the phone case. Place phone on wireless charger.</li> <li>3. Contact Life Fitness Customer Support Services.</li> </ol>	OFF

## Troubleshooting - Wireless Headphones

Before connecting headphones to the console:

1. Connect headphones to mobile device (if not already connected).
2. Turn volume level on mobile device / headphones to maximum volume.
3. Connect headphones to the console.

# 7. Manager's Configuration

## Access Systems Options

1. Select **Language** icon from Attract Screen to access the **Select Language** screen.

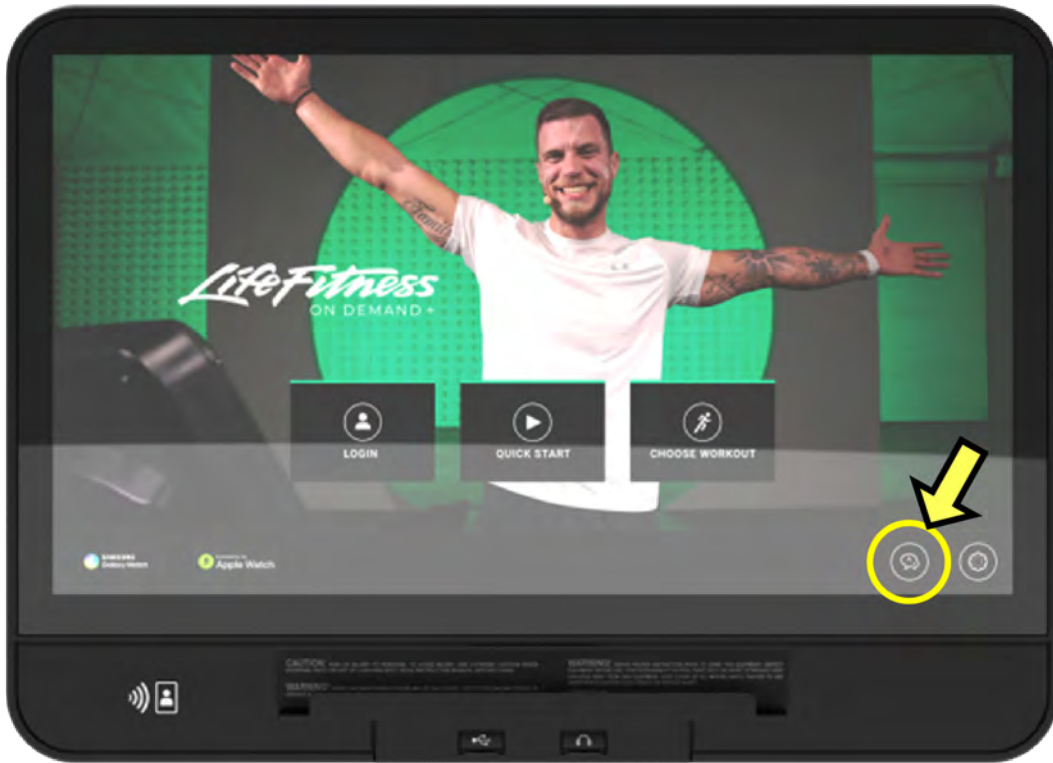

2. Tap the bottom part of the **Select Language** screen in the following sequence: **Lower-Left, Lower-Right, Lower-Left, Lower-Right**.

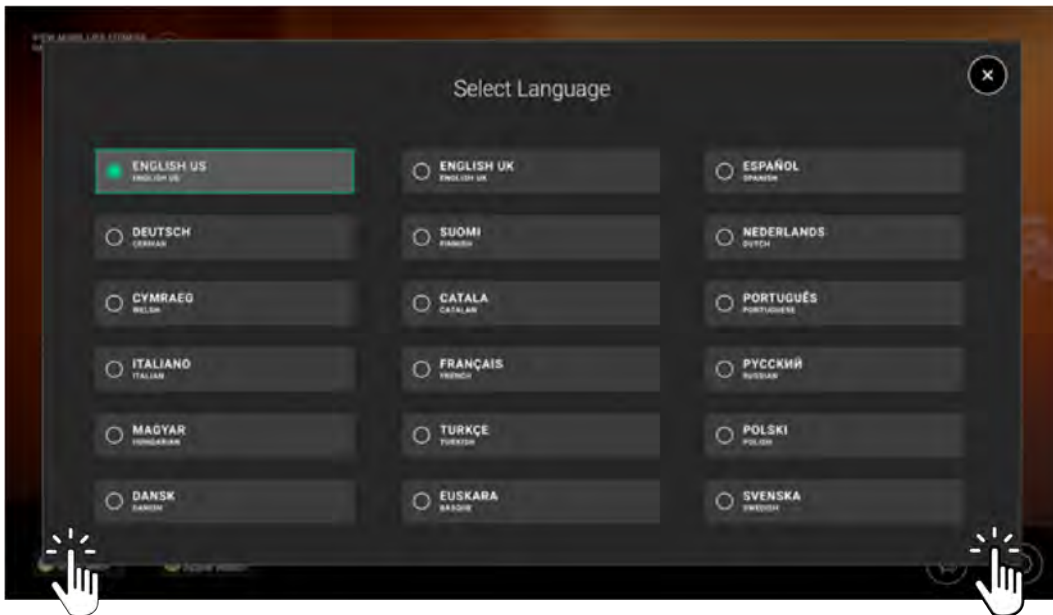

**NOTE:** Make sure you tap INSIDE the black square!

3. Navigate through the System Options menu to **Configuration > Manager**.

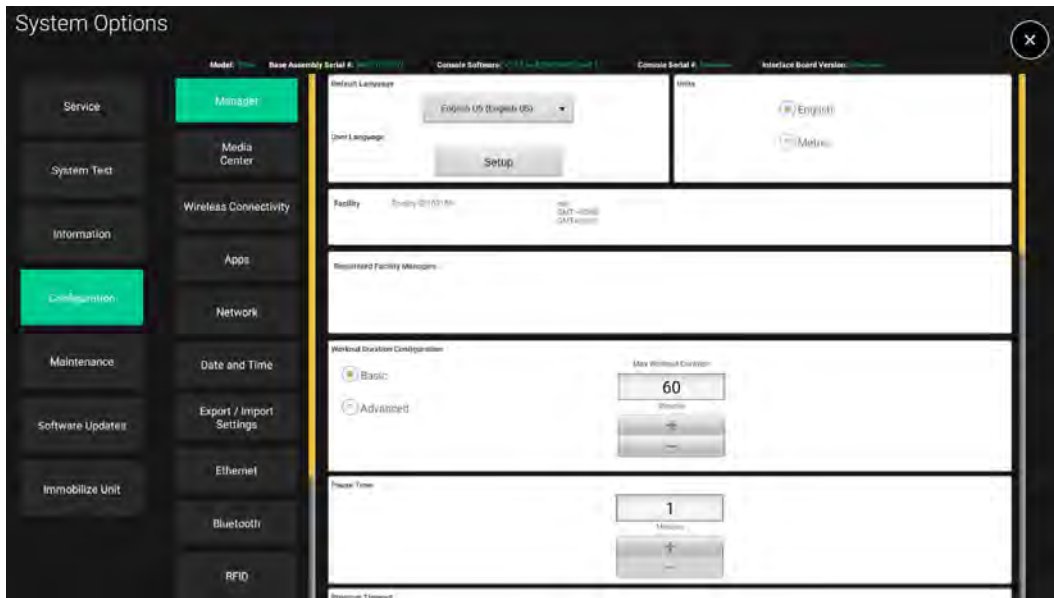

# Default Settings

## Cardio Bases

Setting	Default	Description
Default Language	English U.S.	This option sets a new default language. Options include: English US, English UK, Spanish, German, Japanese, Dutch, Simplified Chinese, Traditional Chinese, Portuguese, Italian, French, Russian, Korean, Turkish, Polish, Finnish, Hungarian, Arabic, Catalan, Basque, Welsh, Hebrew, Danish and Swedish.
User Language	English U.S.	This option presents a list of all possible languages a user could choose to select from, and the ability to reorder them. The default is the full set of languages. Options include: English US, English UK, Spanish, German, Japanese, Dutch, Simplified Chinese, Traditional Chinese, Portuguese, Italian, French, Russian, Korean, Turkish, Polish, Finnish, Hungarian, Arabic, Catalan, Basque, Welsh, Hebrew, Danish and Swedish.
Units	English	Set the measurement unit type for weight, distance, height, and speed. Choices are English Imperial or Metric.
Facility	N/A	This section contains automatically generated facility ID information used for Halo.
Smart Lighting	Enabled Brightness: Default Color: Sky	Smart lighting can be turned On or Off with the <b>Enabled</b> button Three brightness settings: Darker, Default, Brighter 16 color choices 
Registered Facility Managers	N/A	This section contains all registered facility managers added in Halo.
Workout Duration Configuration	Basic; 60 Minute Maximum	Set maximum workout duration limits ranging from 20-240 minutes. Advanced setup allows for setting the duration of 2 different peak times.
Pause Time	1 minute	Set the maximum time during which a workout can remain in pause mode. Ranges from 1-99 minutes.
Program Timeout	30 seconds	The amount of time, ranging from 20 - 255 seconds, a user can go without touching the LCD touch screen during workout setup before the unit resets and returns to the Home Screen. The user will be logged out, any changes made to language are lost and any Bluetooth devices will be disconnected.
Power Saver	ON / 30 minutes	When turned on, this setting allows the base and console to enter "Power Saver" mode after the selected time of inactivity. Ranges from 0-23:59 hours. 30 minutes is the default setting.

Setting	Default	Description
Auto Off / Auto On	OFF	Set the time of day for the system to automatically turn off the LCD touch screen backlight. Set time of day for backlight to turn on and a separate time for the backlight to turn off.
System Sounds	ON	This option controls whether the system speaker beep is generated on key presses.
Wireless Charging Configuration	ON	This sets when the wireless charger can be used to charge compatible devices. Choices include: ON / OFF / Workout Only
Marathon Mode	Disabled	This option only applies to a Time Goal workout. It allows the user in this workout to have unlimited duration if Enabled. Time Goal workouts will adhere to the Workout Duration Configuration setting if Disabled.
Nightly Reboots	OFF	When turned On, the console will detect the least active time of day for the unit and automatically reboot every 24 hours at that time. This is recommended for optimal functioning of streaming services, like On-Demand Workouts, Streaming Interactive Terrains or Netflix.
On-Demand Workouts	OFF	This option activates complete access to the growing library of Life Fitness instructor-led classes. <b>NOTE:</b> The library will only appear if the unit is connected to the internet. 2.5 Mbps of bandwidth per unit recommended for optimal functioning.
Streaming Interactive Terrains	OFF	This option activates complete access to the library of Streaming Interactive Terrains workouts. <b>NOTE:</b> The library will only appear if the unit is connected to the internet. 2.5 Mbps of bandwidth per unit recommended for optimal functioning.
Login Advertisement	Enabled	Sets if the console advertises login options from the main attract screen.
Telemetry	Enabled	Switching on the telemetry feature makes it possible to use the Polar®/ANT+-compatible Heart Rate Zone Training exercises with a Polar/ANT+ telemetry heart rate chest strap for monitoring heart rate.
Speed Increase Limiting with Up Key	Enabled	When enabled and when the speed increase button is pressed and held, the user will only be able to increase the speed in 3 mph increments before needing to let go and press and hold again. When disabled, the user will not be able to press and hold to increase speed.
Fit Test Plus	ON	Turns off all Fit Tests except for the Life Fitness Fit Tests when "Off".

### Symbio Runner Only

Setting	Default	Description
Maximum Speed	16.0 MPH (25 KPH)	Set the maximum speed for treadmill belt to operate. Ranges from 0.5-16 MPH (0.5 - 25 KPH).
Minimum Speed	0.5 MPH (0.8 KPH)	Set the minimum speed for treadmill belt to operate. Ranges from 0.5-16 MPH (0.5 - 25 KPH).
Maximum % Incline	15.0	Set the maximum incline allowed for treadmill deck. Ranges from 0-15.0%.

Setting	Default	Description
control pad Speed Keys <i>(applicable to specific models)</i>	Enabled	This option allows the user to assign belt speed to Walk / Jog / Run values.
Stride Sensor <i>(applicable to specific models)</i>	ON	If turned On, this option automatically pauses the workout if the user steps off the belt.
Acceleration Rate	3	The rate at which the treadmill accelerates to the selected speed. Range from 1 (slowest) to 5 (fastest).
Deceleration Rate	3	The rate at which the treadmill decelerates to the selected speed. Range from 1 (slowest) to 5 (fastest).

## TV

### 1. Select Tuner Type.

- **DTV** is the default selection for PRO:IDIOM™ (Coax or IPTV), DVB and ISDB configurations.
- **STB SYNC** is the default selection for STB SYNC and STB Connector Kit configurations.
- **Open IPTV** is the default selection for streaming media on IP using RTP, UDP, and similar protocols.

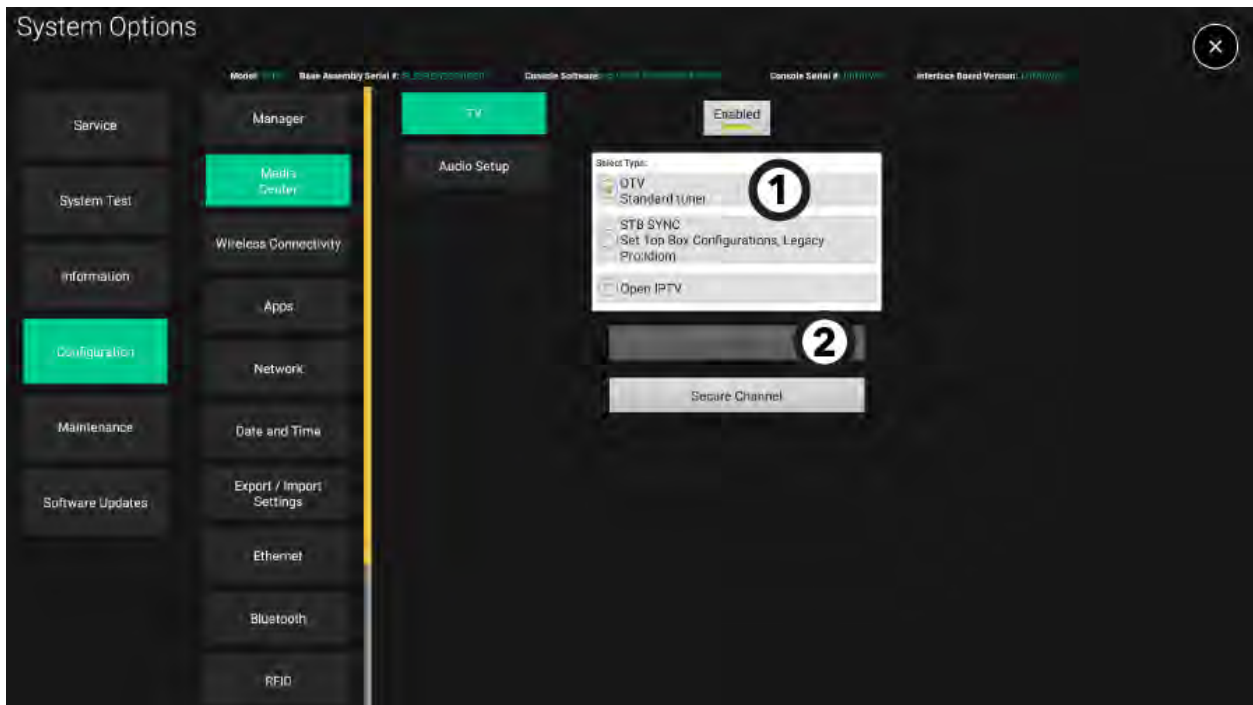

### 2. Press **Set Up TV** to view the screen for the chosen tuner configuration.

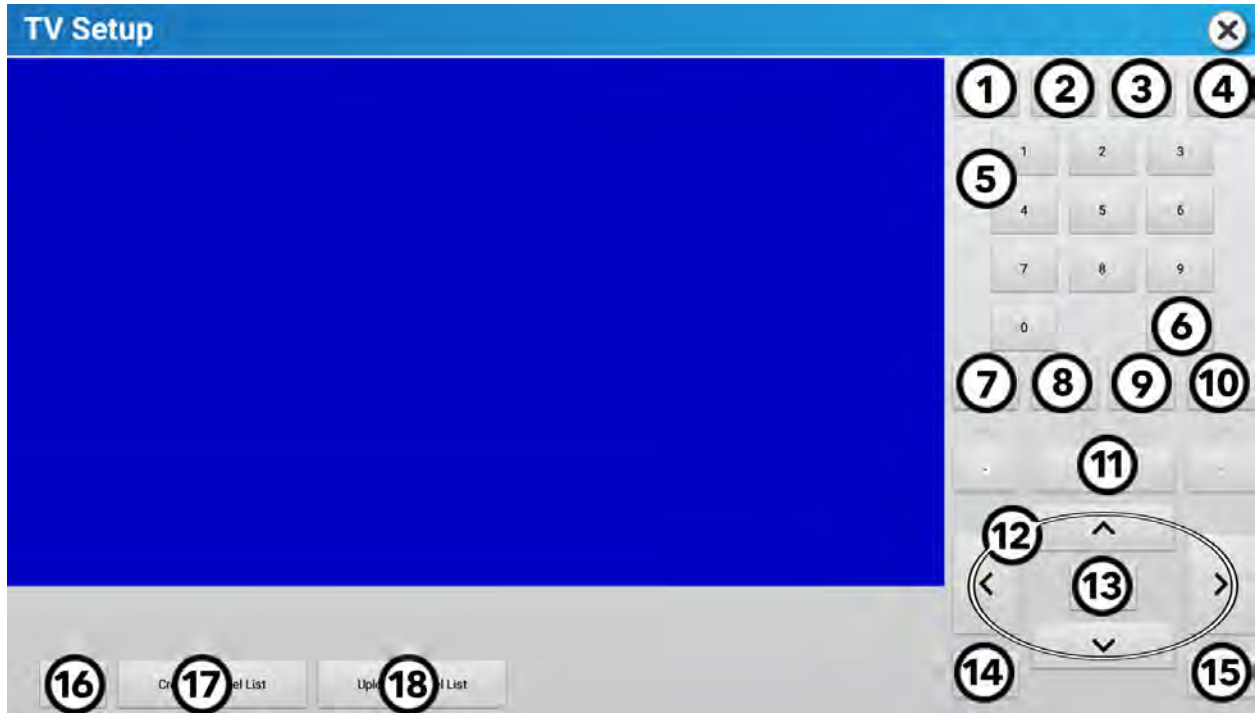

1	<b>PMode</b>	Set Picture Mode.	10	<b>CH</b>	Press + and - to change channels.
2	<b>Zoom</b>	Picture Size.	11	<b>Display</b>	Current channel information is shown.
3	<b>EPG (if available)</b>	Lists current and upcoming programs for selected channels.	12	<b>Up and Down / Left and Right arrows</b>	Press to navigate the TV Setup menu options.
4	<b>Mute</b>	Silence TV audio.	13	<b>Enter</b>	Make Selections.
5	<b>Keypad</b>	Use for manual channel input. Use the hyphen (-) to input major-minor channel numbering.	14	<b>Exit</b>	Press to exit the TV Setup menu.
6	<b>Prev</b>	Press to view previous channel.	15	<b>Menu</b>	Press to access: <ul style="list-style-type: none"> <li>• Channel settings</li> <li>• Picture settings</li> <li>• Sound settings</li> <li>• Time settings</li> <li>• Lock settings</li> <li>• Setup settings</li> </ul>
7	<b>VOL</b>	Press + and - to change audio volume.	16	<b>Reset</b>	Resets tuner to default state.
8	<b>SAP (if available)</b>	Press to activate Secondary Audio Programming (SAP).	17	<b>Create Channel List</b>	Create a list of channels for users to access during workouts.
9	<b>CC</b>	Press to turn Closed Caption (or Subtitles) On / Off.	18	<b>Upload Channel List</b>	Uploads channel list to Halo Fitness Cloud (if connected) and instantly to all other units in the facility if units are connected to the internet.

## TV Channel Scan for Pro:Idiom™ Tuner over Coax

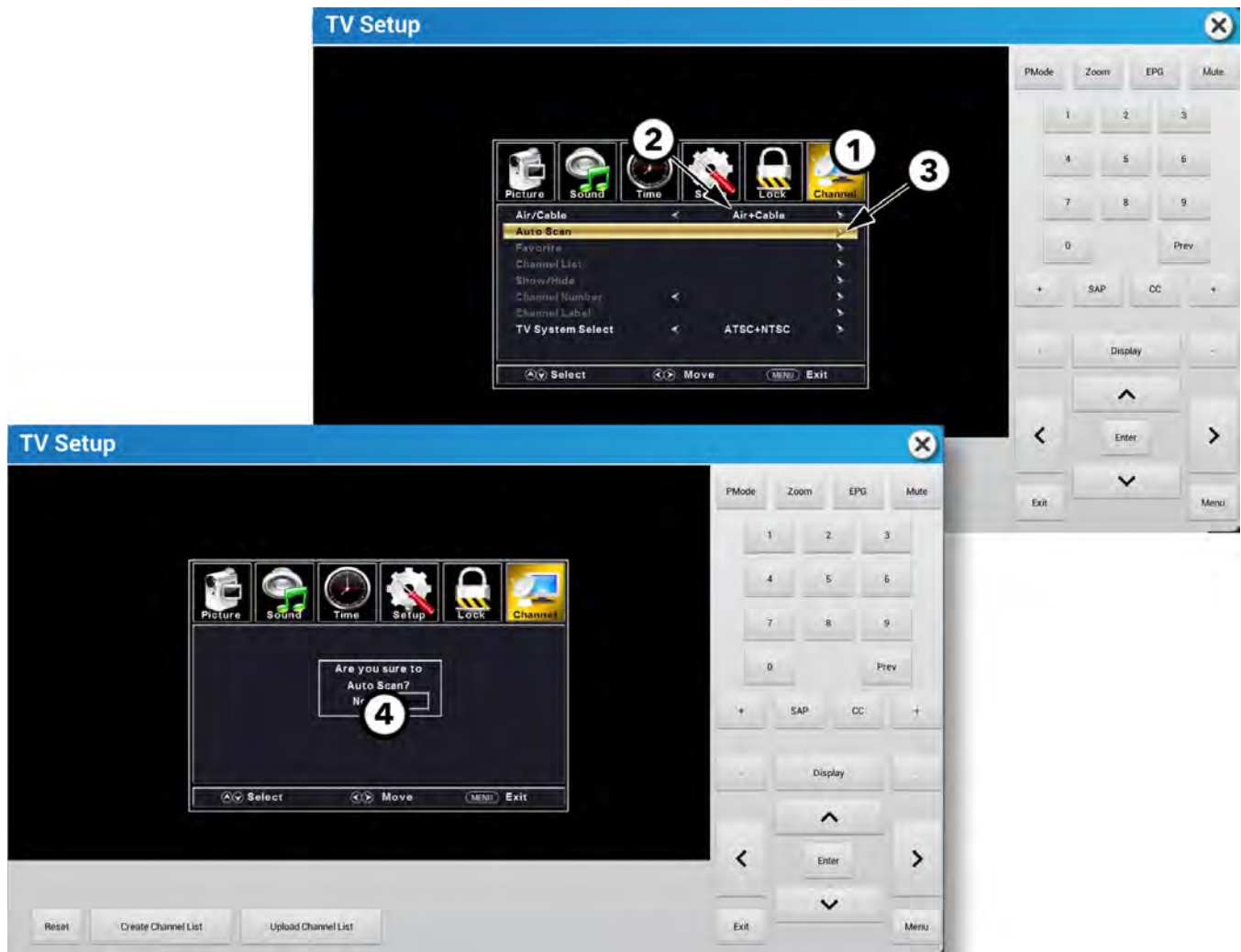

1. Press ◀ or ▶ to navigate to **Channel**.
2. Press ▲ or ▼ to navigate to **Air/Cable**, and press ◀ or ▶ to select your configuration.

### NOTE:

- **Cable** scans for Pro:Idiom encrypted digital, clear digital, and analog channels.
  - **Air** scans for digital ATSC channels from local terrestrial antenna.
  - **Air + Cable** scans for all signal types.
3. Press ▲ or ▼ to navigate to **Auto Scan**, and press ▶ or **Enter** to scan for channels.
  4. Press ◀ or ▶ to select **No** or **Yes**, and press **Enter**.

## TV Channel Scan for DVB Tuner

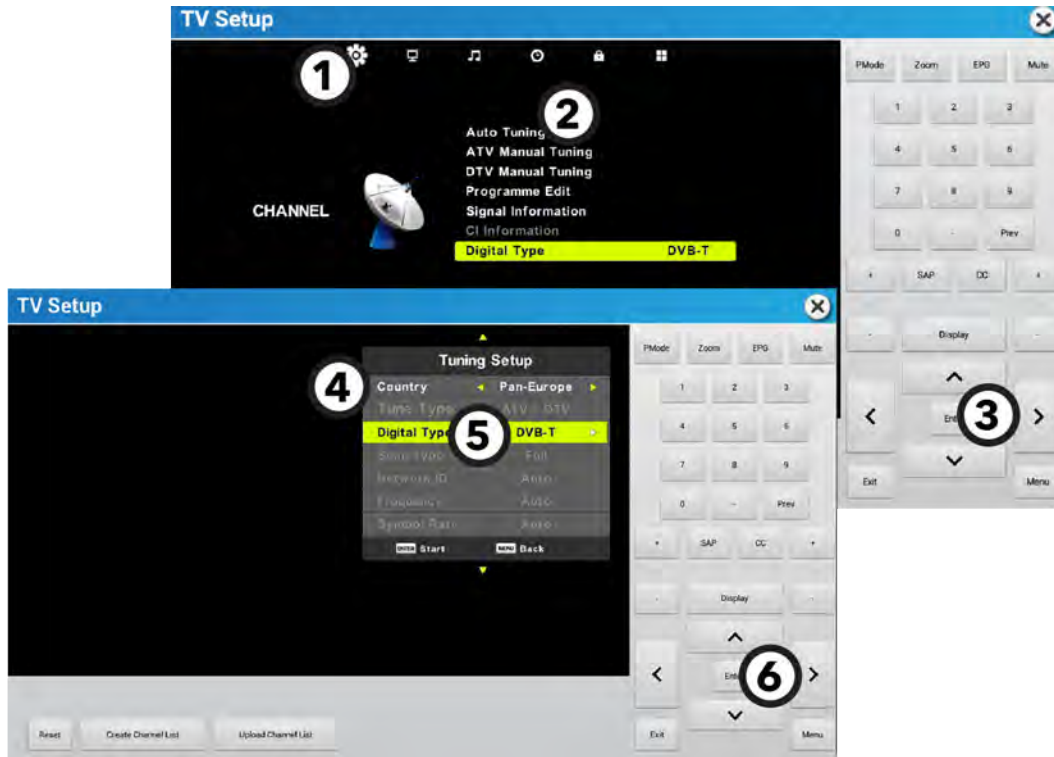

1. Press ◀ or ▶ to navigate to **Channel**.
2. Press ▲ or ▼ to navigate to **Auto Tuning**.
3. Press **Enter**.
4. Press ▲ or ▼ to navigate to **Country**, then press ◀ or ▶ to select your country.
5. Press ▲ or ▼ to navigate to **Digital Type**, then press ◀ or ▶ to select your digital TV standard.

If **DVB-S** is chosen for the **Digital Type** select **Country** and **Satellite** type using the ◀ or ▶ before initiating the channel scan.

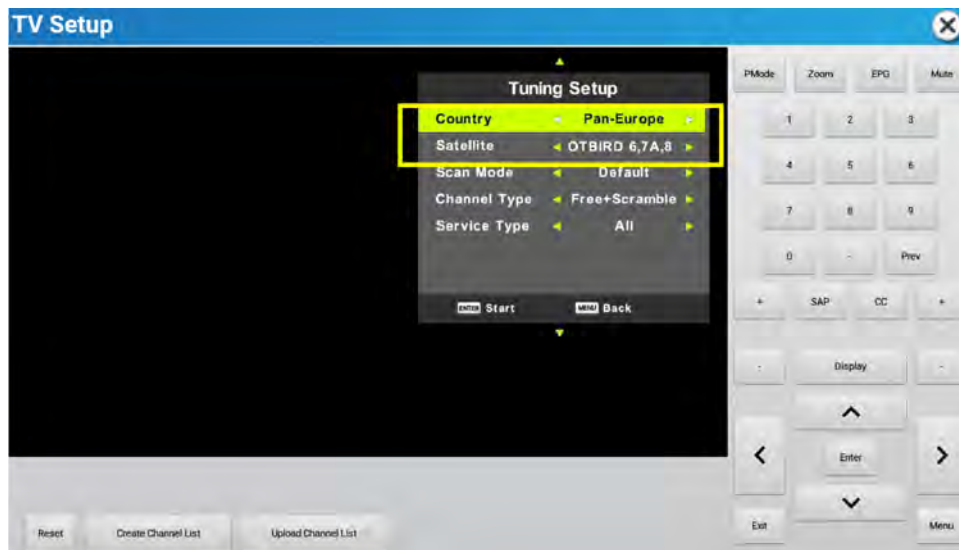

6. Press **Enter** to scan for channels.
7. Press ▲ or ▼ to navigate signal type if **DVB-S** is selected as the **Digital Type**.

## TV Channel Scan for ISDB-T Tuner

Select **Scan** from the TV Setup Menu options.

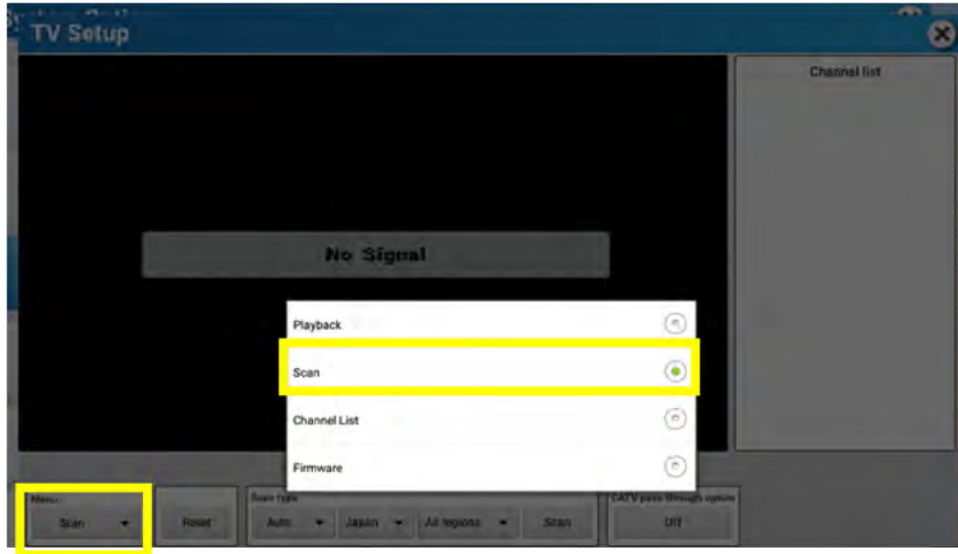

1. Select **All Regions** to pull up a list of regions. Choose applicable region.
2. Set the **CATV Pass Through Option** to **OFF**.
3. Choose **Auto** for **Scan Type** selection.
4. Press **Scan** to start scanning for channels.
5. Choose **Playback** from Menu options to view the video.

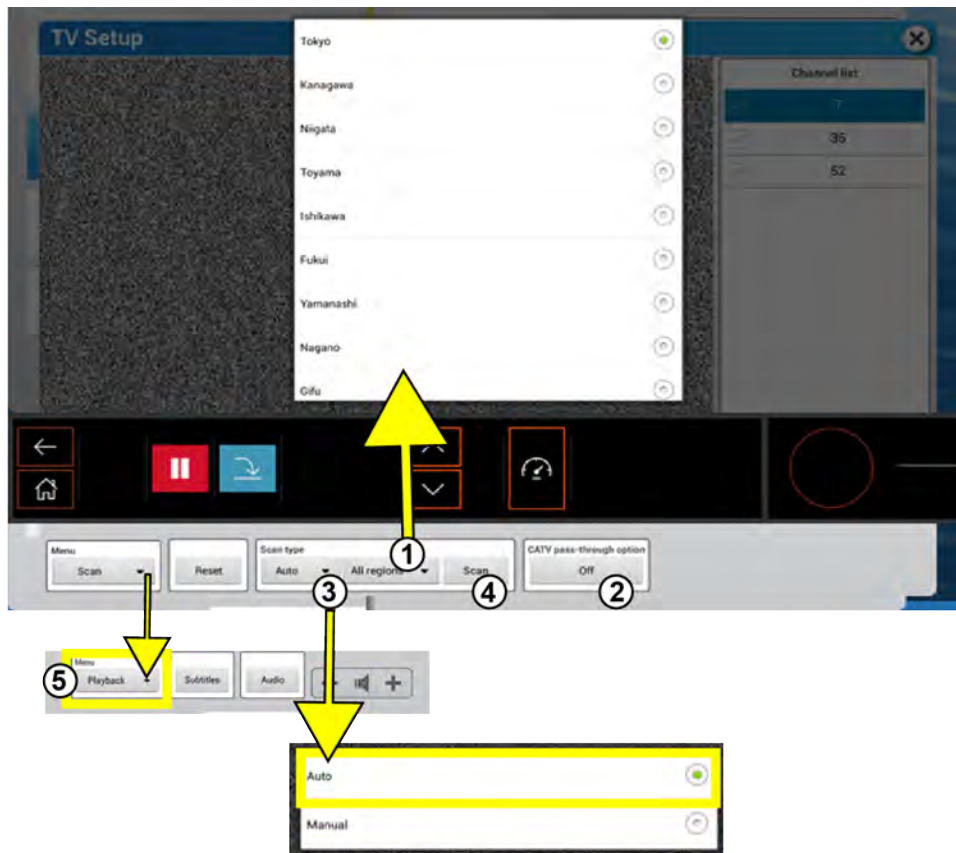

**NOTE:** If the tuner doesn't pick up channels, set the **CATV Pass Through Option** to **ON** and rescan for channels.

## Channel List Management for ISDB-T Tuner

Select **Channel List** from the TV Setup Menu options.

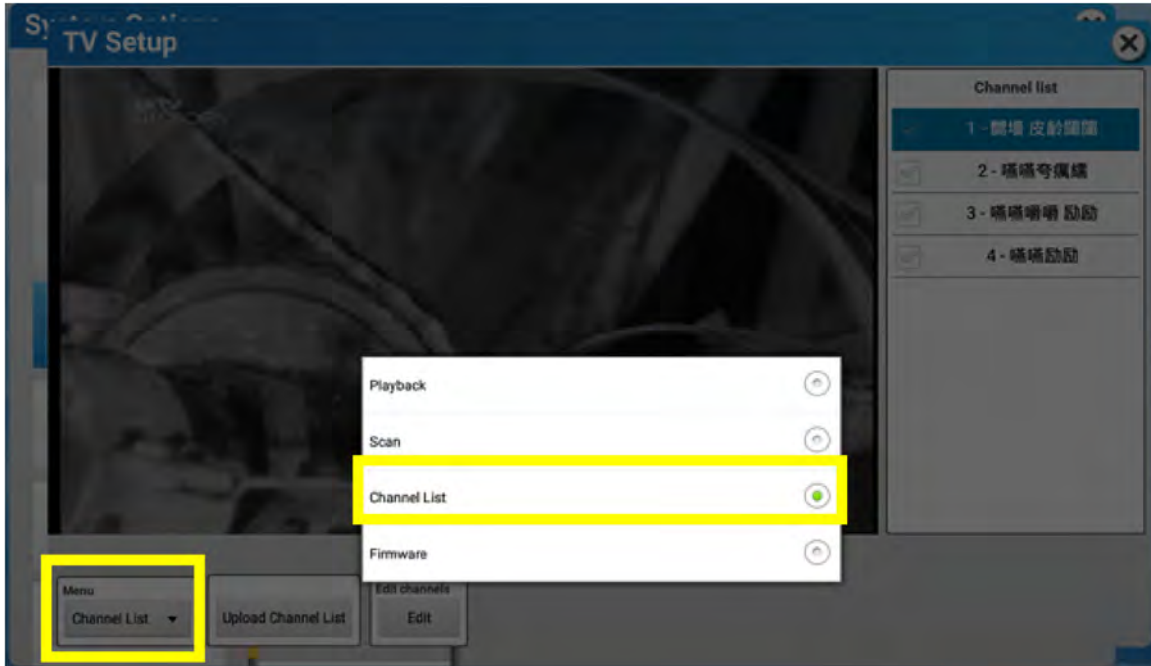

1. Select **Upload Channel List** to upload a channel list to Halo Fitness Cloud (if connected).

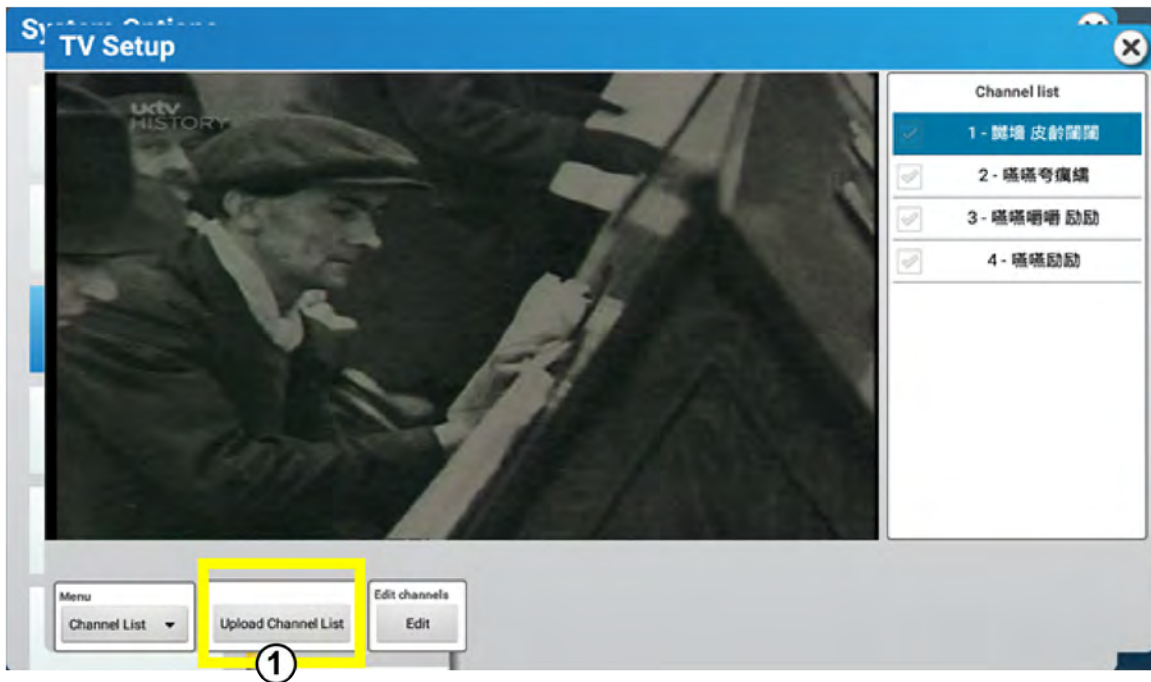

2. Select **Edit** to edit the channel list. Uncheck channels to hide the channels from the user. Hidden channels will not be options during workouts.

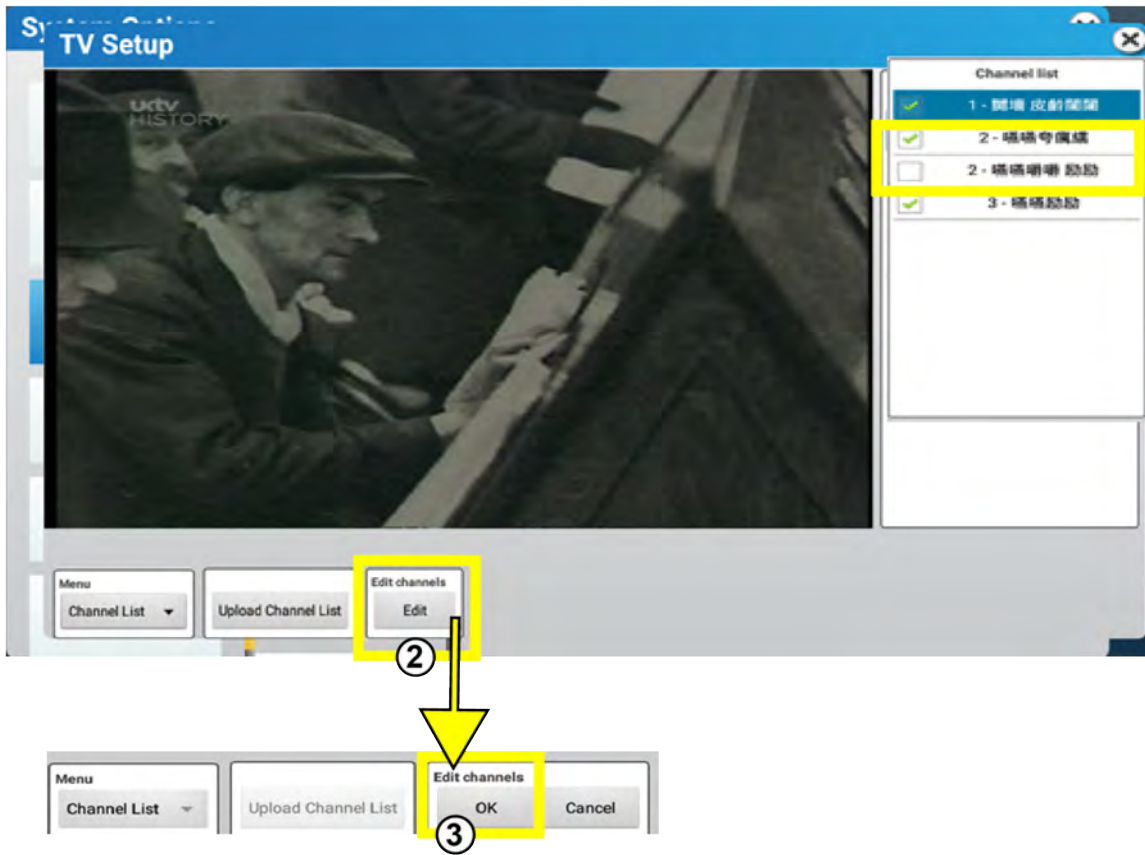

# Pro:Idiom™ IPTV Tuner

## Prerequisite requirements.

Facility will need to provide:

- **Access to their IPTV network** through a CAT-5e/CAT-6 wired connection for each and every Life Fitness cardio product containing the Pro:Idiom IPTV DTB. Do not support Pro:Idiom over a WLAN connection.
- **Static IP address (IPv4 - 32-bit) assignment** for every piece of cardio equipment containing the Pro:Idiom IPTV DTB.
- **VLAN (virtual LAN) ID tag assignment** if one is required.
- **Channel list information** including the streaming protocol used (UDP is the most common), the IP address for each channel, the port assignment, and the channel name associated with each channel. IP address, port, and channel name associated with each channel.

## Limitations

- The Pro:Idiom IPTV DTB does not support dynamic IP address assignment.
- The Pro:Idiom IPTV DTB does not support Pro:Idiom encrypted IPTV over Wireless Connectivity (or WLAN).

## Initial Setup

- The initial setup of a fitness facility with the Pro:Idiom IPTV DTB requires obtaining vital setup information including static IP address assignment for each DTB and the IPTV channel list from the A/V integrator or facility manager for integration into the DTB directly. Without this information, this DTB cannot be setup.
- Every Pro:Idiom DTB within a facility will need to be manually programmed with a [Static IP Address](#) as well as the [VLAN ID](#) (if one is required).
- The [IPTV Channel List](#) will need to be implemented on one Pro:Idiom DTB and can be cloned to the rest within the facility using the USB Import/Export or via Halo.

## Technical Specifications

IPTV Input:	RJ-45 style via CAT-6 wired Ethernet
IPv4 Addressing:	Static IP assignment only
IPv4 Multicast IP Support:	Yes
IGMP Support:	Yes
VLAN Support:	Yes
IPTV Streaming Protocols:	UDP and RTP
IP Multicast Range:	224.0.0.0 - 239.255.255.255
Port Assignment:	0001-9999
Transport Stream Support:	Single Program Transport Stream (SPTS) and Multiple Program Transport Stream (MPTS) up to 20Mbps
Video Codec Support:	MPEG-2, MPEG-4, H.264, HEVC
Audio Codec Support:	MPEG Layer 1/2, Dolby, AAC
Pro:Idiom Decryption Support:	Yes

## Static IP Address

Every Pro:Idiom™ IPTV DTB needs to be programmed with a Static IP address. The Static IP address assignment or range should be provided by the facility manager or A/V integrator.

**First Time Setup menu:** Follow the instructions to setup the tuner setup parameters. During this First Time Setup, enter this Static IP address.

If the First Time Setup menu is exited, the DTB menu can be accessed by:

1. Navigate to **System Options > Configuration > Media Center > DTV Option > Set Up TV.**
2. Select **Menu** in the lower right corner of the TV Setup window.



3. Press ◀ or ▶ to navigate to **Setup**.
4. Press ▲ or ▼ to navigate to **Network Settings**. Press Enter or ▶.

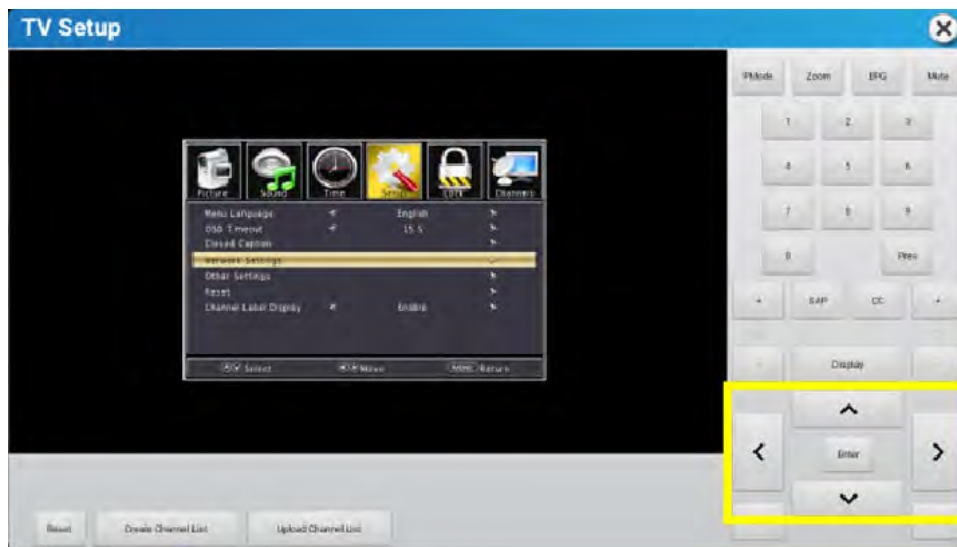

5. Enter the Static IP address under **Device IP** section. Each of the 4 boxes (the first is in green) needs to be filled out using the numeric keypad and right and left arrows for navigation. In the example below, the static IP address for this unit is 192.168.0.100.

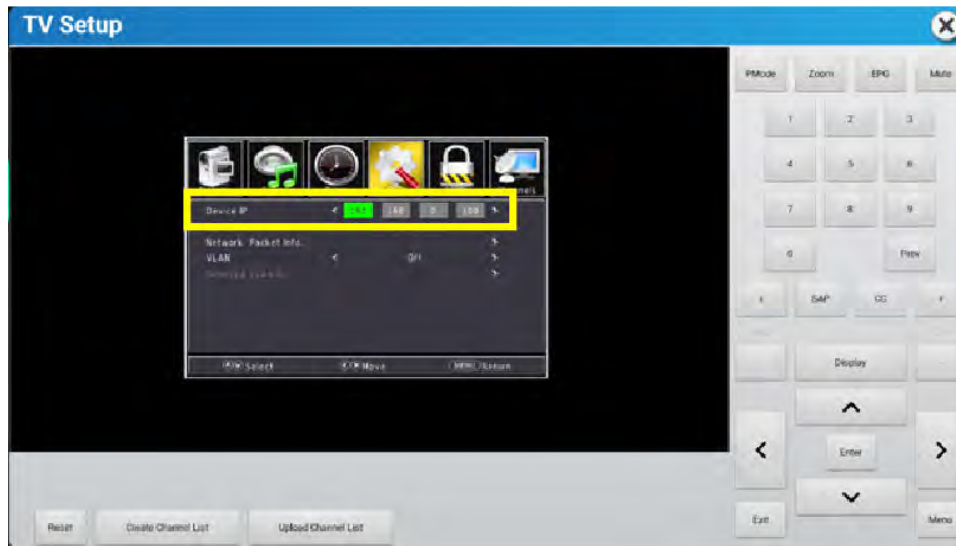

6. After the Static IP address is entered, you can then enable VLAN (Virtual Local Area Network) to add in a VLAN ID or VLAN tag assignment. The VLAN ID is to be provided by the facility manager or A/V integrator. This feature is not required but assists with directing traffic that contains both Internet and IPTV together.

**NOTE:** If a VLAN ID is not required, skip the VLAN ID setup section.

### VLAN ID Setup

1. Use the navigation arrows and enable VLAN to **ON**.



2. Navigate to **Selected VLAN ID**. Press **Enter** or **▶** to access the VLAD ID Input table.

3. Enter in the Port VLAN ID (or PVID for short) which is a default VLAN ID that is assigned to designate the VLAN segment to which this port is connected. Any additional VLANs that are needed to access the IPTV traffic can be placed in the adjacent boxes starting left to right. Any changes will be saved after exiting.



### IPTV Channel List

This section covers how to create and build the initial IPTV channel list.

### Channel List Provided (Example)

Number	IP Address	Port	Channel Number	Channel Name
1	239.10.10.23	1234	1-1	AMC
2	239.10.10.24	1234	1-2	FX
3	239.10.10.25	1234	2-1	SYFY
4	239.10.10.26	1234	3-1	TRV
5	239.10.10.27	1234	4-1	WEATH
6	239.10.10.28	1234	5-1	HIST
7	239.10.10.29	1234	6-1	TNT
8	239.10.10.30	1234	7-1	WTTW
9	239.10.10.31	1234	8-1	ESPN
10	239.10.10.31	1234	8-2	WFLD
11	239.10.10.31	1234	8-3	CNN
12	239.10.10.31	1234	8-4	ABC
13	239.10.10.31	1234	8-5	NBC
14	239.10.10.31	1234	8-6	WGN
15	239.10.10.31	1234	8-7	CBS

### Channel Setup: Manual Channel List Setup

1. Press ◀ or ▶ on the TV menu to navigate to **Channels**.

2. Press ▲ or ▼ to navigate to **Input Channel IP Address**. Press **Enter** or ►.



3. Input the first channel's IP multicast address and port number using ◀ or ▶ to navigate to each cell. Press **Enter** to save channel. Repeat for every channel within the channel list.

**NOTE:**

- IP multicast address range is from 224.0.0.0 through 239.255.255.255
- Port assignment is typically 4 digits and follows the multicast address with a colon (:).
- Example: 239.10.10.23:4598



4. Press ▲ or ▼ to navigate to **Auto Channel Scan**. Press Enter or ►.



5. A prompt to confirm your selection will appear. Press ◀ or ▶ to select **No** or **Yes**. Press Enter.



After the scan, all channels with the correct address and port assignment parameters will playback content.

6. To view or edit the full channel list navigate to the **IP Channel List Edit**. Verify that all channels within the channel list are tuned and are displaying content as expected. Any issues can be resolved using the **IP Channel List Edit**.

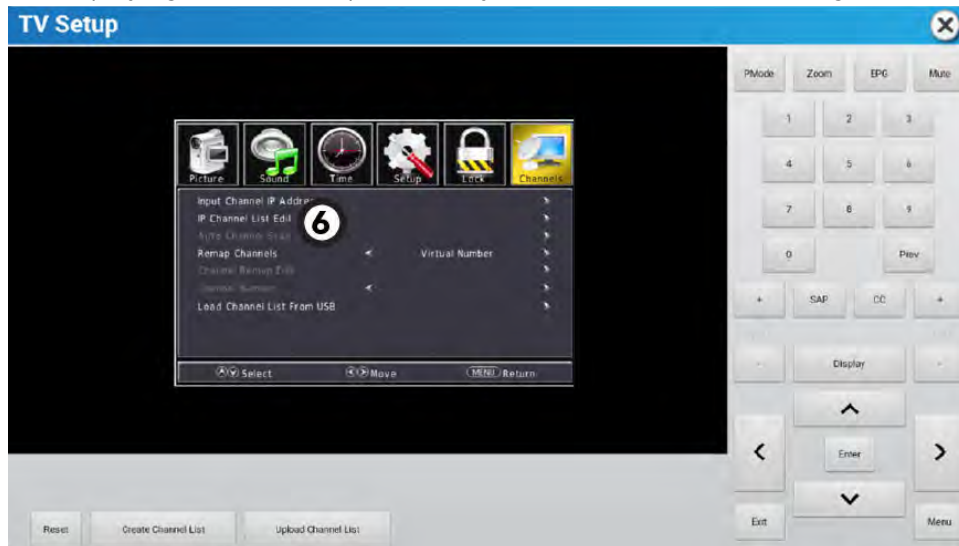

7. Repeat the **Auto Channel Scan** as necessary.

## Create Channel List

After all the channels have been verified, use the **Create Channel List** function to import the channel list to the console GUI. A dialog box will appear and show progress.

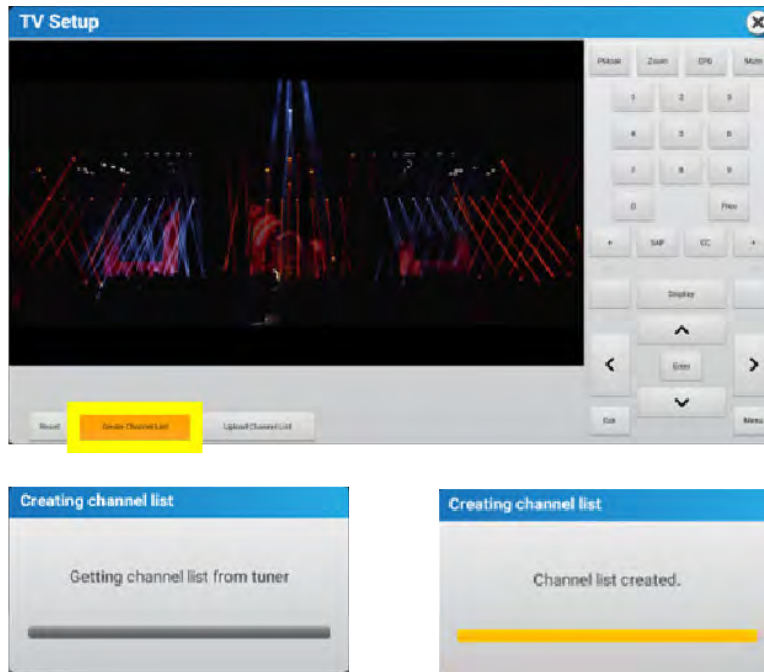

Exit **System Options** and launch a workout to verify the TV channels show up properly.



## Console Settings Export / Import Feature

Console settings can be Exported and Imported between local consoles using the front panel USB port. This will transfer any changes to the System Options menu including the tuner channel list to other local consoles.

**NOTE:** Create Channel List function must be executed before you can Export the channel list properly.

1. Insert a blank USB flash drive into the front panel of the console of which you want to Export the settings from. This should be the console where the tuner is set up and the channels are scanned into.

2. Navigate to **System Options > Configuration > Export / Import Settings.**

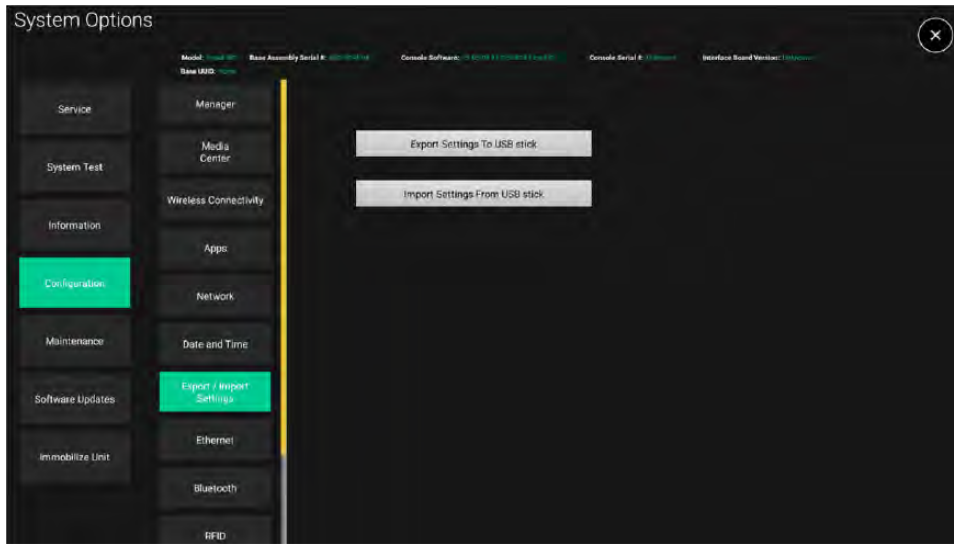

3. Select **Export Settings to USB stick.** A prompt will show progress.

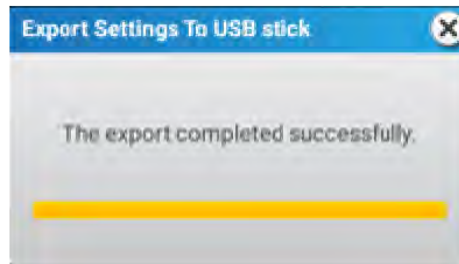
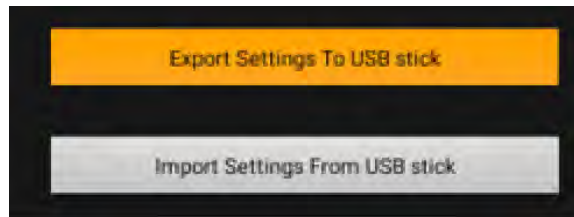

4. After a successful Export, insert the USB flash drive into a console that does not have the settings, and navigate to **System Options > Configuration > Export / Import Settings.**
5. Select **Import Settings from USB stick.** A prompt will show progress.

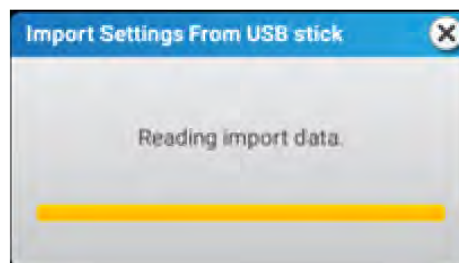
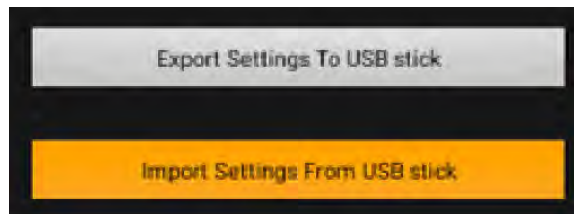

6. Repeat Import process on every console within the facility that does not have the console settings.

**NOTE:** Tuner channel lists will only import if the tuner is the same tuner type and on the same software version.

### Upload Channel List

Feature to push a channel list to Halo for channel management and sending the channel list to other Halo connected Discover consoles within the facility that share the same tuner type and tuner software version.

Navigate to the **TV Setup** menu and select **Upload Channel List**. A prompt will appear showing progress.

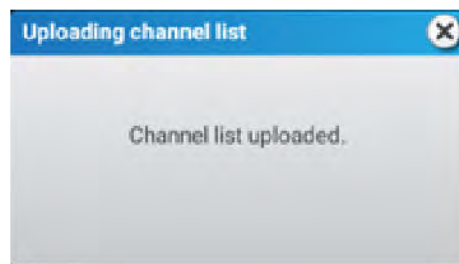
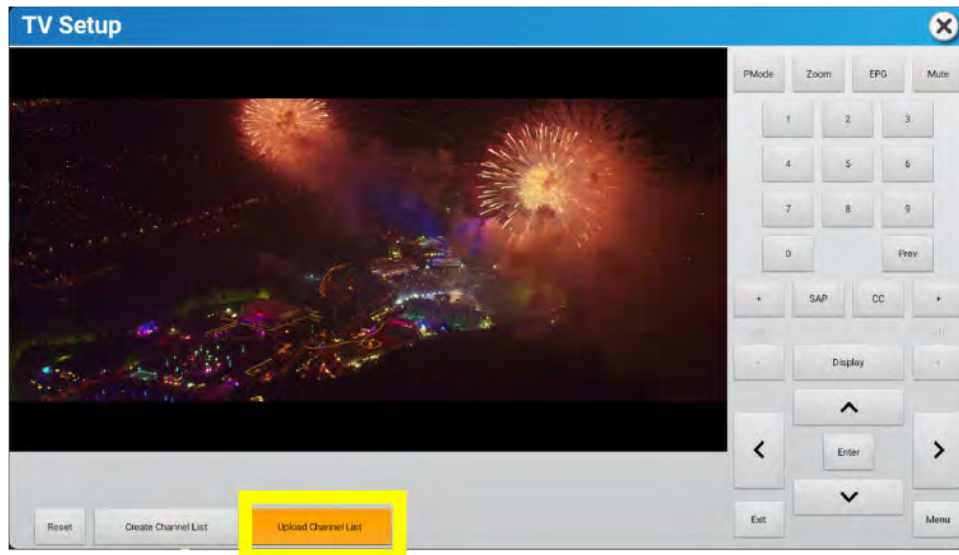

Using a Halo account for the specific facility, you can edit the channel list and publish the changes down to the rest of the units within the facility.

### Software Update Process: Automatic Update

Updates for this tuner have been added to the LF software update package only via the console's front panel USB port. The tuner will not be updated through a cloud connection to Halo. If the DTB does not have the latest firmware, the DTB updates during the LF software package update process.

The update will happen in two stages, transmission of the data from the console to the DTB and the actual update. This process can take up to 2 minutes.

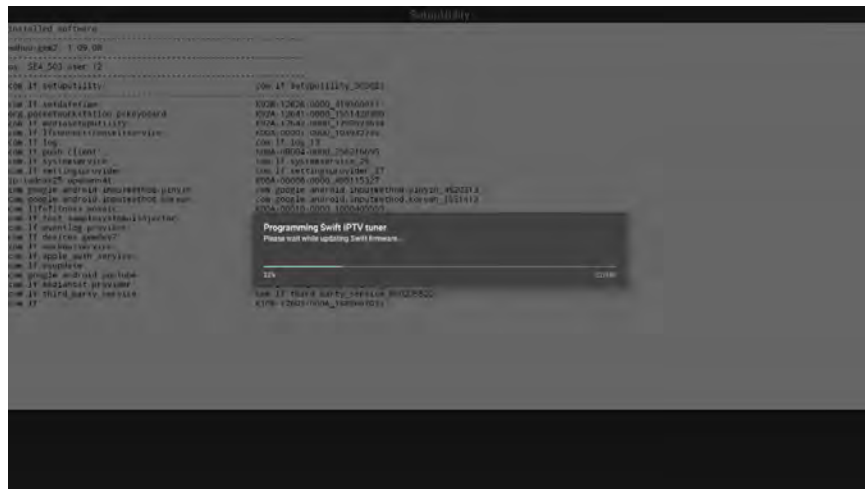
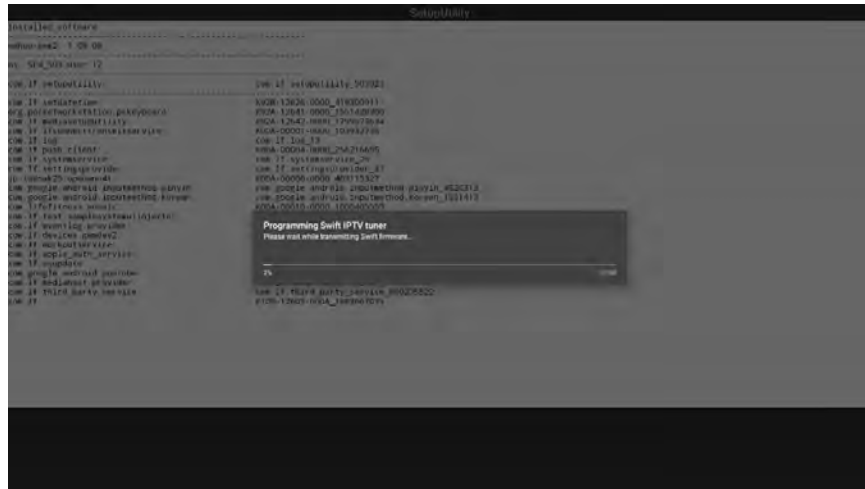

If the update process is not observed during the console update, this is typically because the tuner firmware is already up to date.

## Tuner Type and Tuner Firmware Version Check

To check the tuner type or firmware version, navigate to **System Options > Information > Software Version > Tuner** to see the tuner type and firmware version.

The screenshot shows the 'System Options' interface. The 'Information' menu item is selected, leading to 'Software Versions'. Within this section, the 'Tuner' entry is highlighted with a yellow box. The tuner information is as follows:

Main		Apps Installed	
Part #: 6100-12502-000A		com.ancotel.ots.privatoban	version: 6.1.0-4596705
OS		com.google.android.gms	version: 16.38.40
Version: REL_303 user 12		com.it.worloutservice	version: 1.3.23
Bootloader		com.iffireapp.zbase	version: 1.0.5
1:75C4_502_uark.2		org.mobi.opensudoku	version: 1.05
Firmware Version:		com.ancotel.providers.mds	version: 9
RS Version: 1.30-S_release_imagefyoc_4.1.0		com.it.ottolipovide	version: 2.5.37
Kernel Version:		com.iffireapp.mosai	version: 6.0.0-60810-0601-142708.5
Uboot Version:		com.it.aggit_github_service	version: 1.00.03
LiFe-PANe Version:		com.ancotel.axisremstorage	version: 9
MF Version:		com.ancotel.tetrisolver	version: 9
946f0466731aa004077e72ae85f8f77855d349c		com.ancotel.computereducationmanager	version: 9
SIB Version:		com.ancotel.providers.d.unisa-da	version: 9
SIB ID: 0x00		com.it.guill.dfw	version: 6.0.0.4.0074-0000-5300000
MFID Version:		com.it.mediastufflib	
MD5 ID: 0x00			
MA MCU			
Version: 1.00			
ATC ID:			
JNT-TED-DCX-BSC-DSL-ENG-STLXX-P-B-CXVNS-NA			
Meridian Base SW:			
MD5: 0x00000000			
CSAFE			
Version: Unknown			
<b>Tuner</b>			
type: PR0_000M0VER_IP	version: 0.08		
Memory Size: 64 GB			
Lifecage Media			
Part #: 00000000			

# STB SYNC

**NOTE:** Select the IPTV Setting at installation to match the Set Top Box (STB) brand / model in the facility's AV closet.

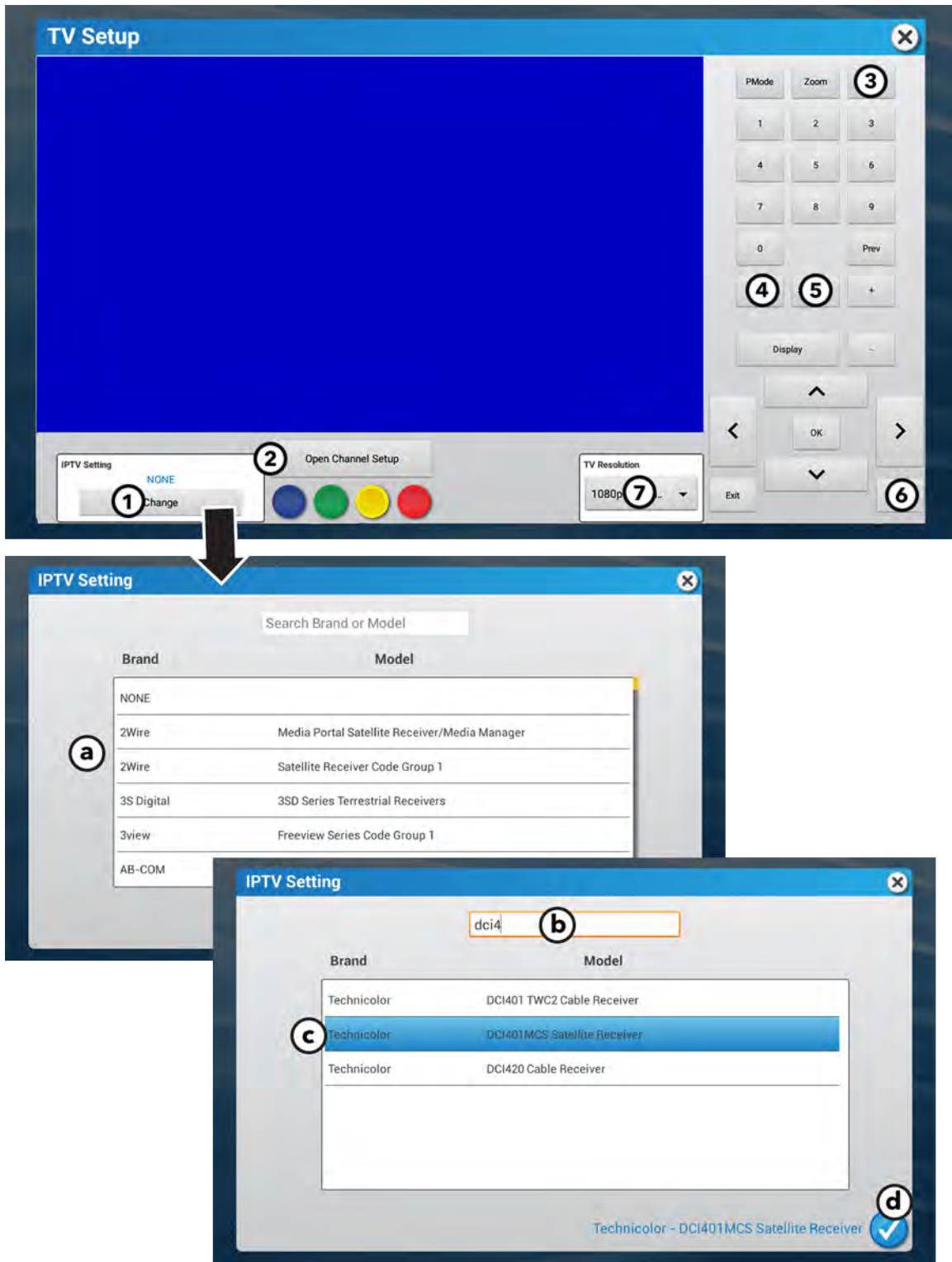

These commands are sent to the corresponding STB. The STB determine the actions. See the STB manufacturer's documentation for detailed functionality and descriptions.

## 1. IPTV Setting

Select **Change**.

Search for the STB brand and model.

- a. Scroll through the list of brands and models, or type the name of the brand or model in the **Search Brand or Model** box.
- b. Select the row with your desired brand and model.
- c. The selected brand and model is displayed.
- d. Press the checkmark to confirm.

**NOTE:** Select the IPTV Setting at installation to match STB brand / model in the facility's AV closet.

**NOTE:** There may be multiple rows for the same brand and model. Each row will have different STB remote control codes, so multiple rows may need to be attempted during configuration.

**NOTE:** Rows containing the model description **Legacy Product - do not use for new console installs** should not be selected manually during installation of new consoles, regardless of whether the corresponding STB is new or not.

## 2. Generic Color buttons

STB defines the actions.

## 3. EPG (*if available*)

Lists current and upcoming programs for selected channels.

## 4. SAP (*if available*)

Toggles between normal and SAP audio channel.

## 5. Subtitles

Press to turn Subtitles On/Off.

## 6. Menu

STB menu (*if available*)

## 7. TV Resolution

Change TV resolution.

- The TV resolution default setting is selected.
- The TV resolution change only applies within the **TV Setup** menu and will be reset back to the default after exiting the **TV Tuner Setup** menu.

## Open Channel Setup

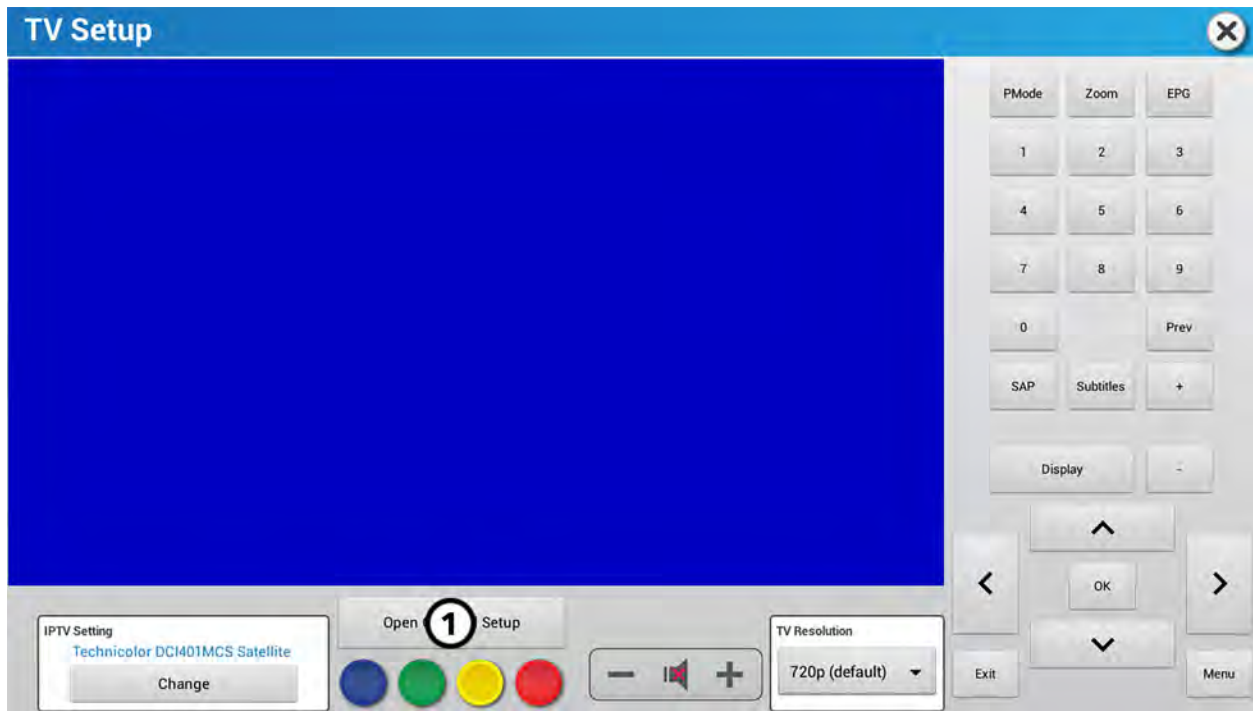

After scanning for channels or installing a STB, press **Open Channel Setup** to customize your channel list for the Workout Screen.

The Open Channel Setup menu has four options:

- [Edit Current](#) - Edit titles, add titles, remove titles, and save titles.
- [Clear Current](#) - Deletes existing channel lists.
- [Import New](#) - Replicates a channel list from a different unit.
- [Export Current](#) - Saves a channel list to a USB flash drive for replication on different units.

## Edit Current

Press **Edit Current** to access the following menu options:

- [Add Channel](#) - Add one or many channels and edit channel titles.
- [Remove](#) - Remove unwanted channels.

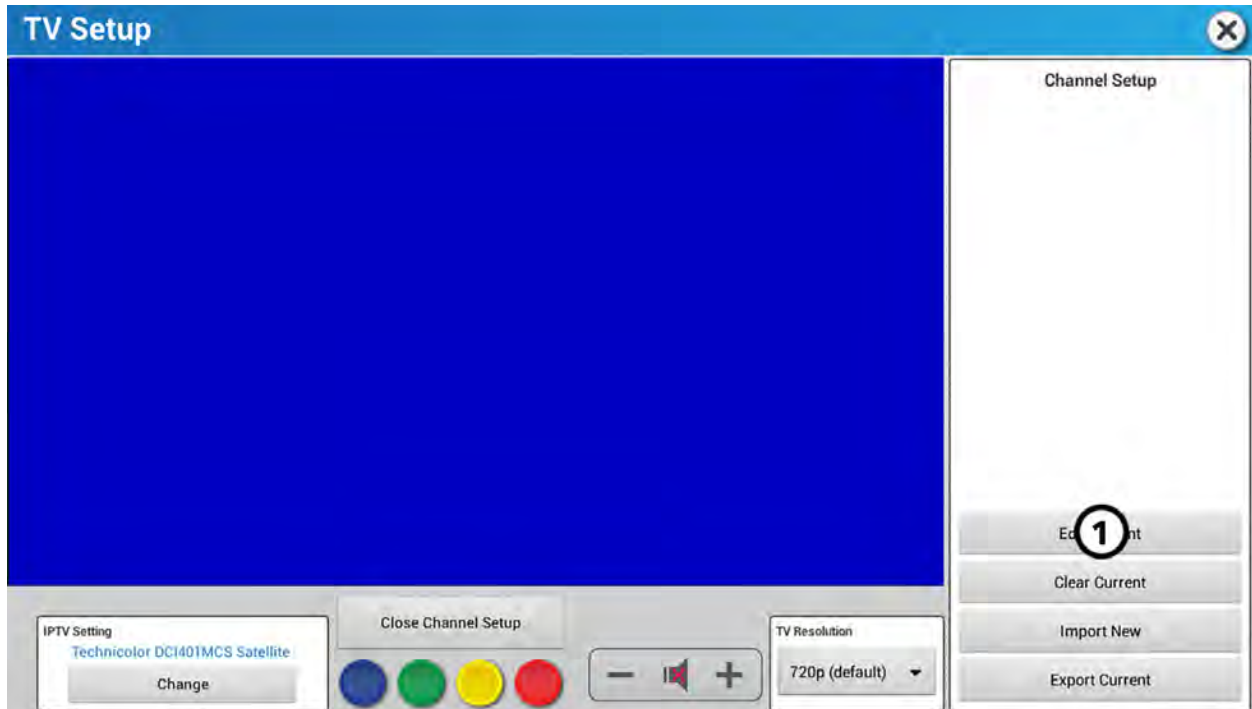

## Add Channel

1. Press **Add Channel**.

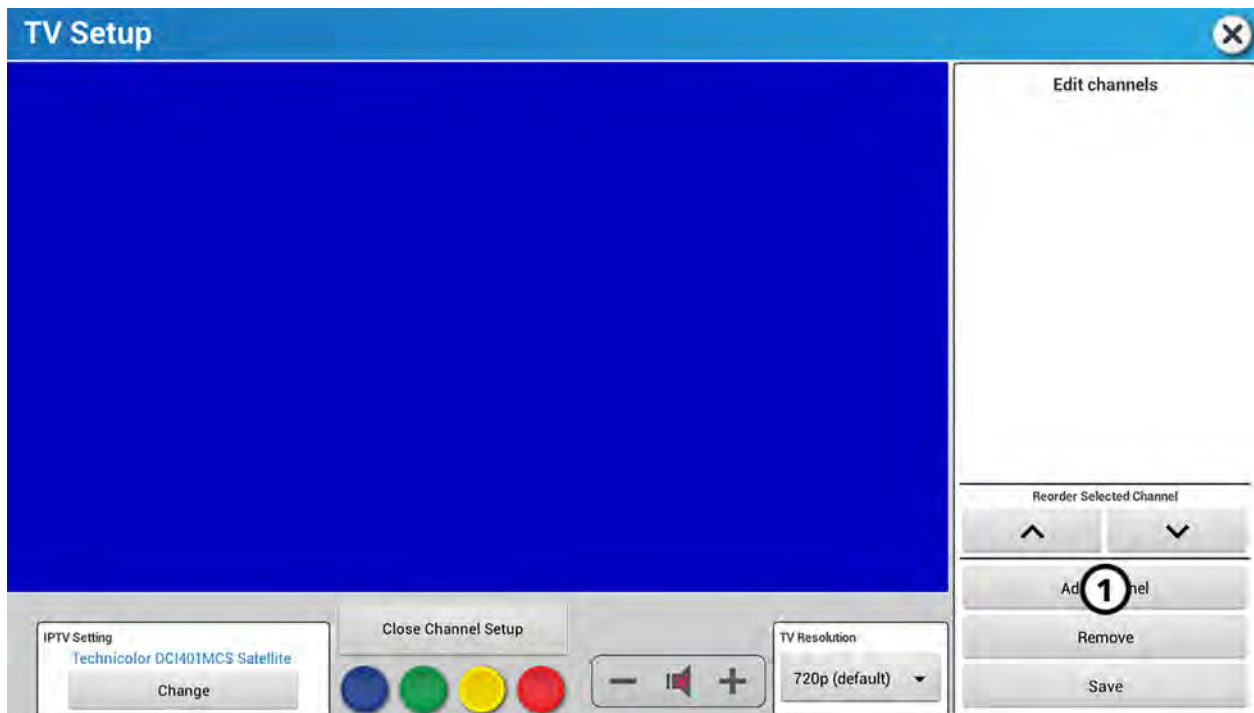

2. Type the channel number in the **Major number\*** box.

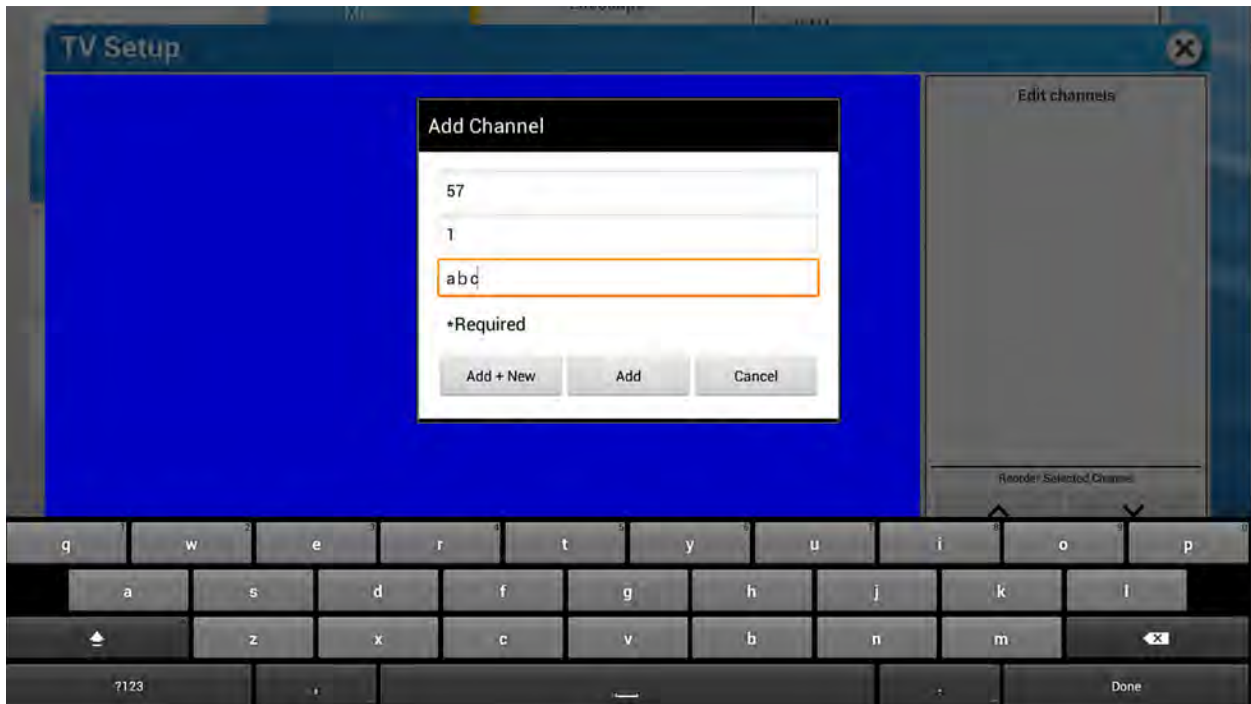

3. Type the channel sub-number or program number in the **Minor number** box.
4. Type the channel name in the **Channel name\*** box.
5. Choose one of the following:
  - Press **Add + New** if you have more channels to add to your channel list.
  - Press **Add** if you have only one channel to add to your channel list.
  - Press **Cancel** if you do not want to add your channel.

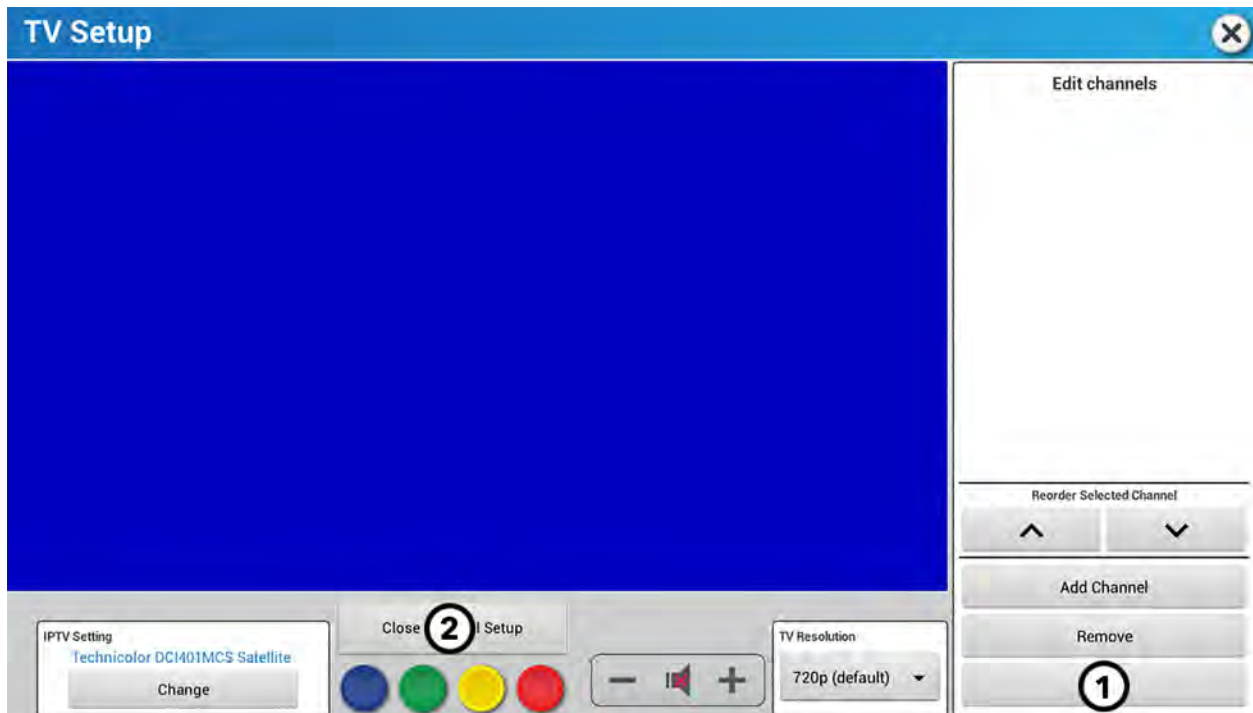

1. Press **Save** when you are finished adding channels.
2. Press **Close Channel Setup** if you are finished with your channel list.

## Reorder Selected Channel

1. Press on the channel you want to reorder on your channel list.

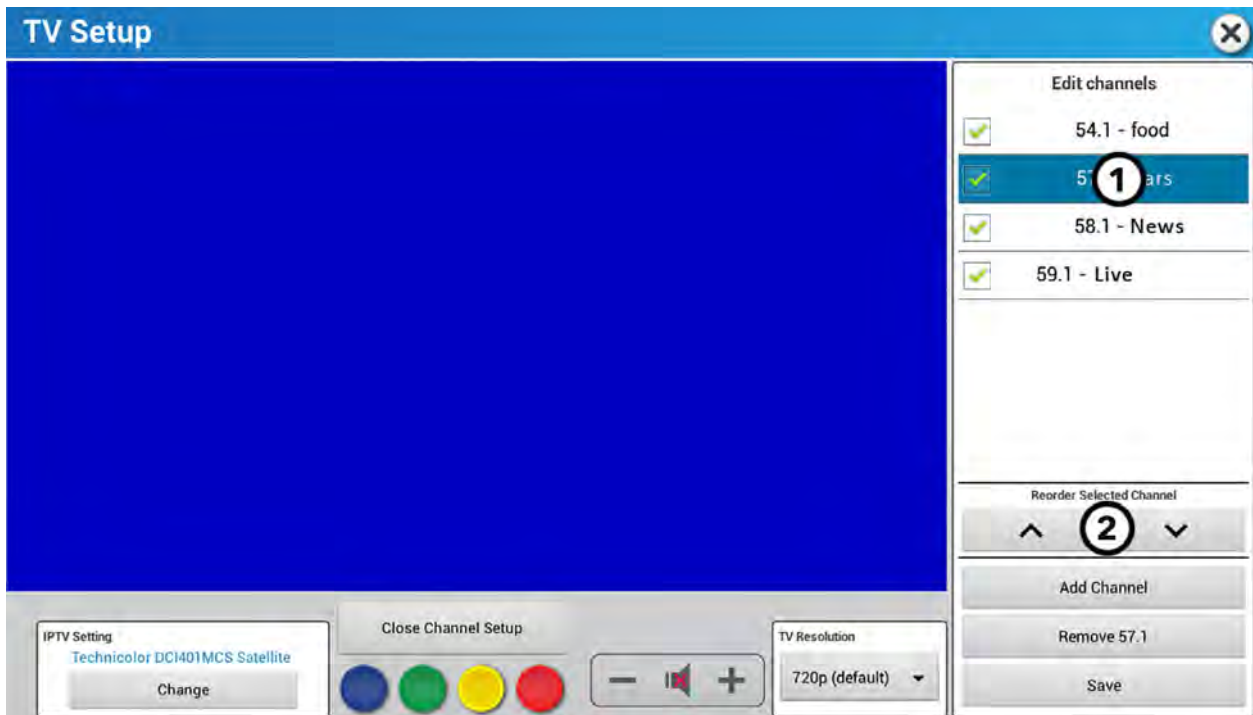

**NOTE:** The order of the channel list that you create will appear within the workout menu.

2. Press ▲ or ▼ to rearrange the channel on your channel list.

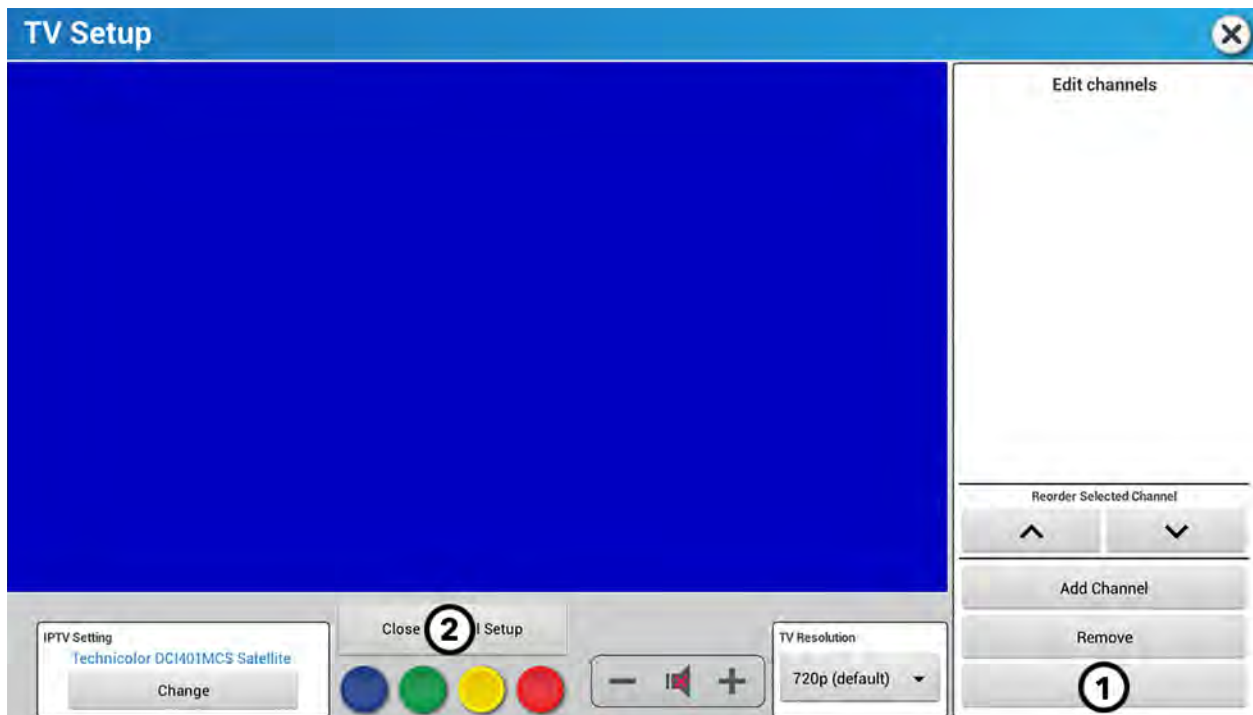

1. Press **Save** when you are finished reordering your channels.
2. Press **Close Channel Setup** if you are finished with your channel list.

## Remove

1. Press on the channel you want to remove from your channel list.

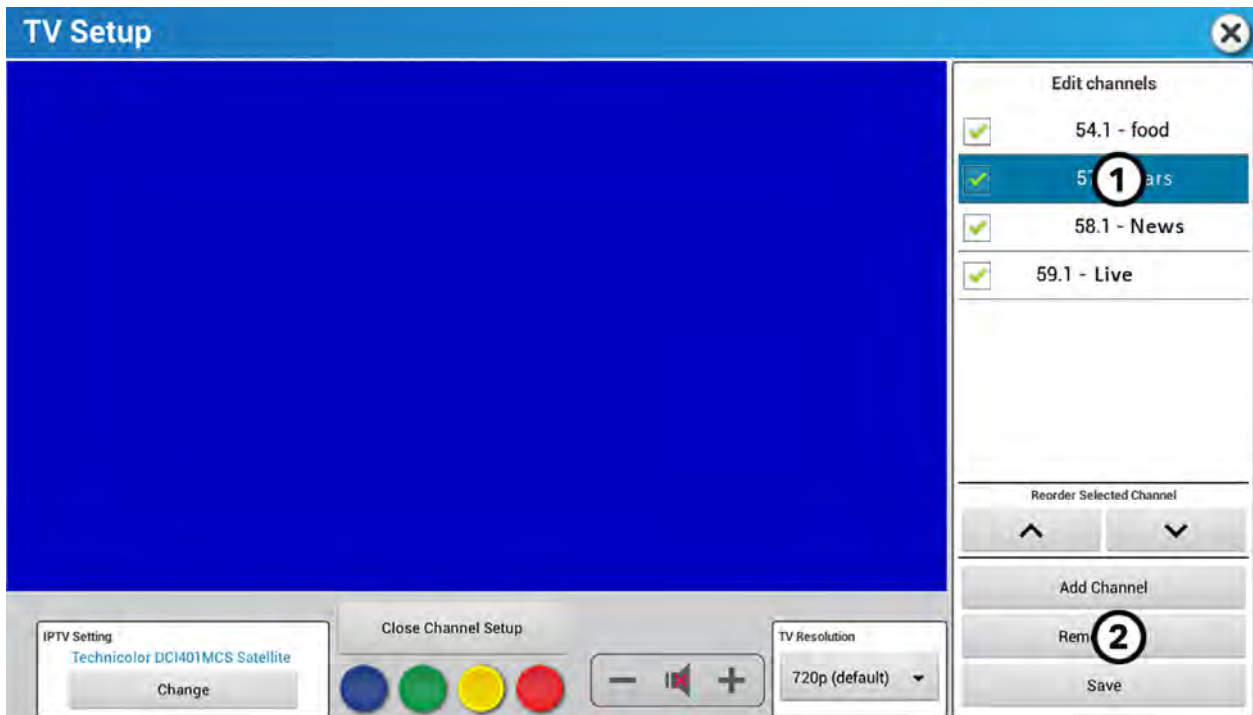

2. Press **Remove**.

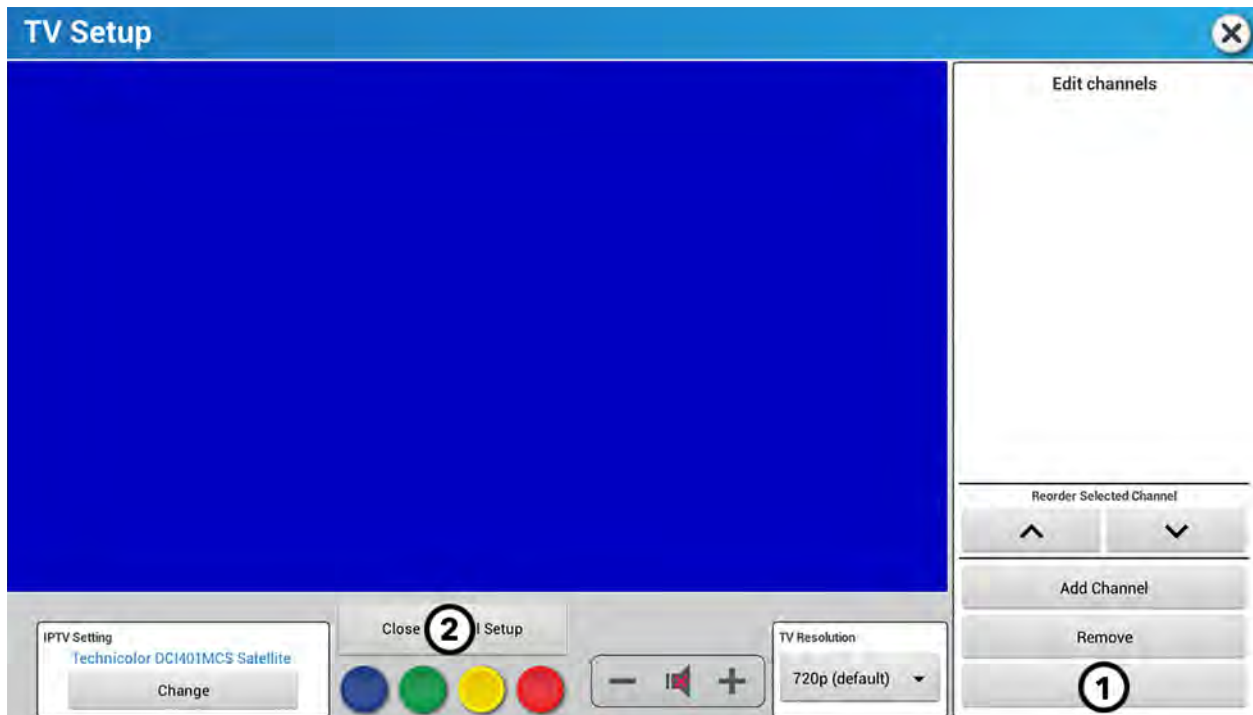

1. Press **Save** when you are finished removing channels.
2. Press **Close Channel Setup** if you are finished with your channel list.

## Clear Current

Press **Clear Current** to delete an existing list of channels, and create a new list of channels.

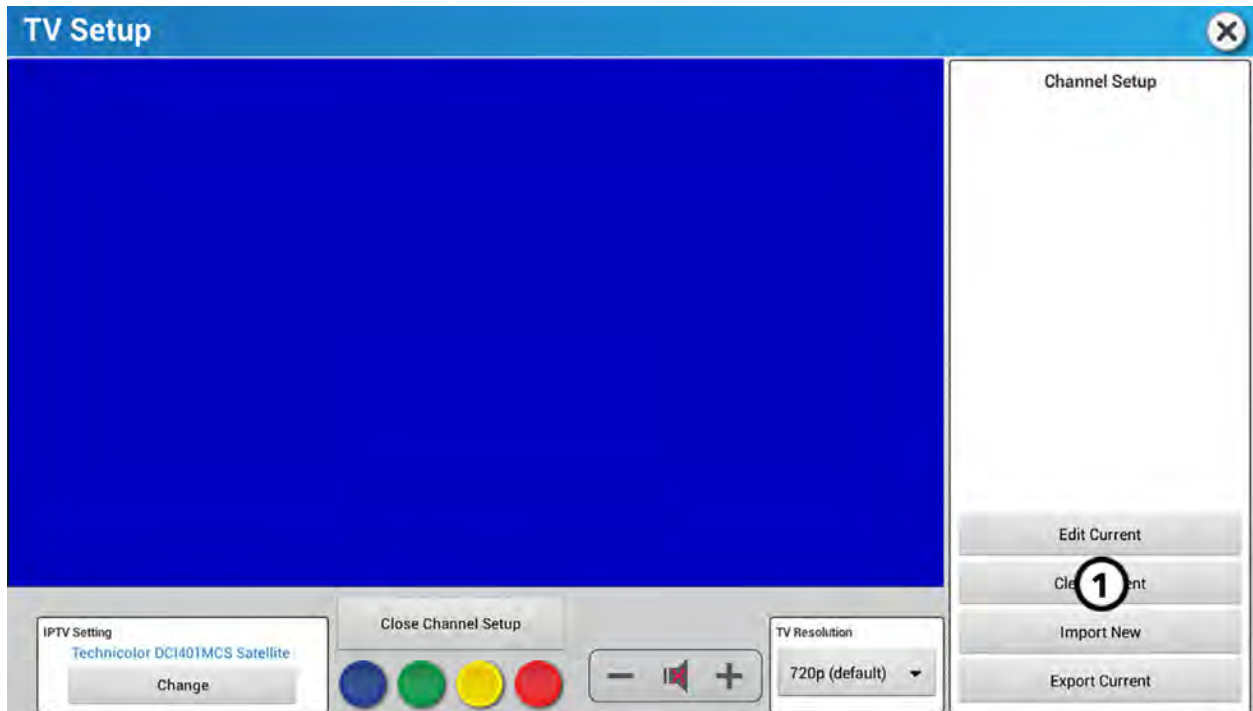

## Import New

The Import New feature requires a channel list on a different unit and a USB flash drive. You will use the Export Current feature on another unit before using the Import New feature.

Import a channel list from a different unit:

1. Locate another unit with a current channel list.
2. Insert a USB flash drive into that unit's USB port.
3. Perform an [Export Current](#) on the that unit.
4. Remove the USB flash drive from that unit.
5. Install the USB flash drive on your unit.
6. Press **Import New**.

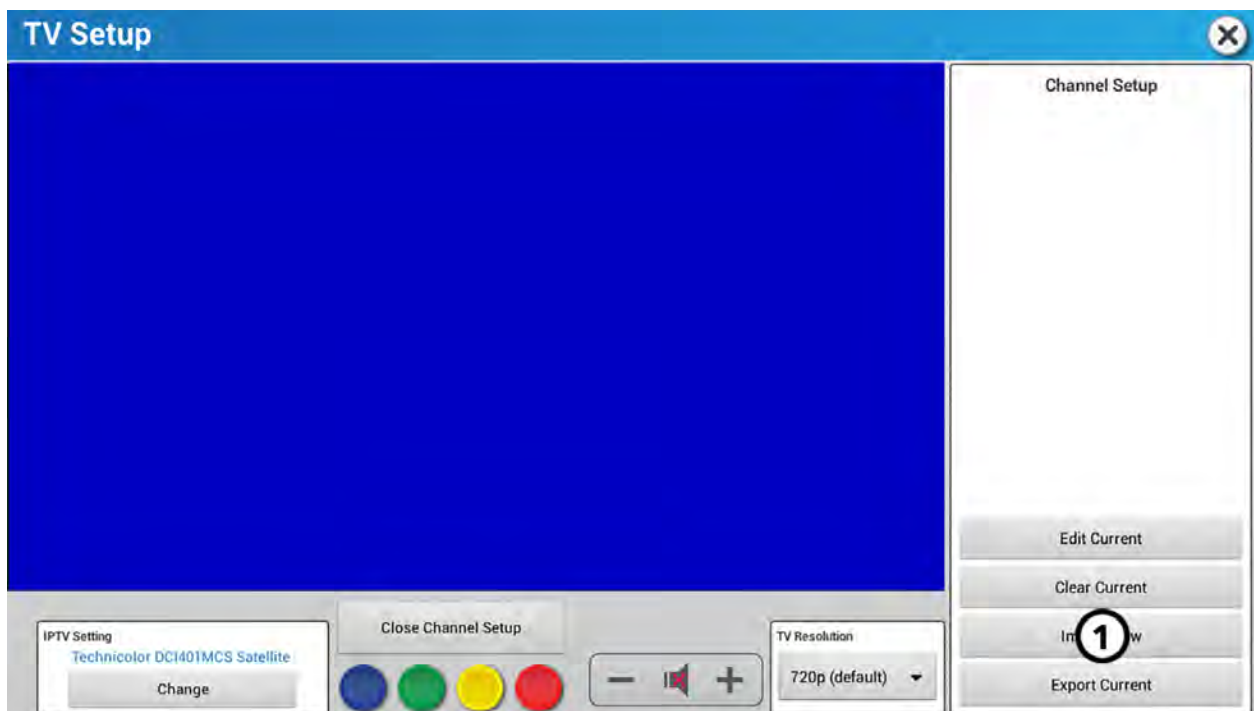

7. Verify that your unit has imported the channel list from the other unit.

### Export Current

The Export Current feature is used when you want to save your current channel list on multiple machines. You will use the Import New feature after using the Export Current feature.

To export a unit's current channel list:

1. Insert a USB flash drive into the front USB port of a unit with a current channel list.
2. Press **Export Current**.

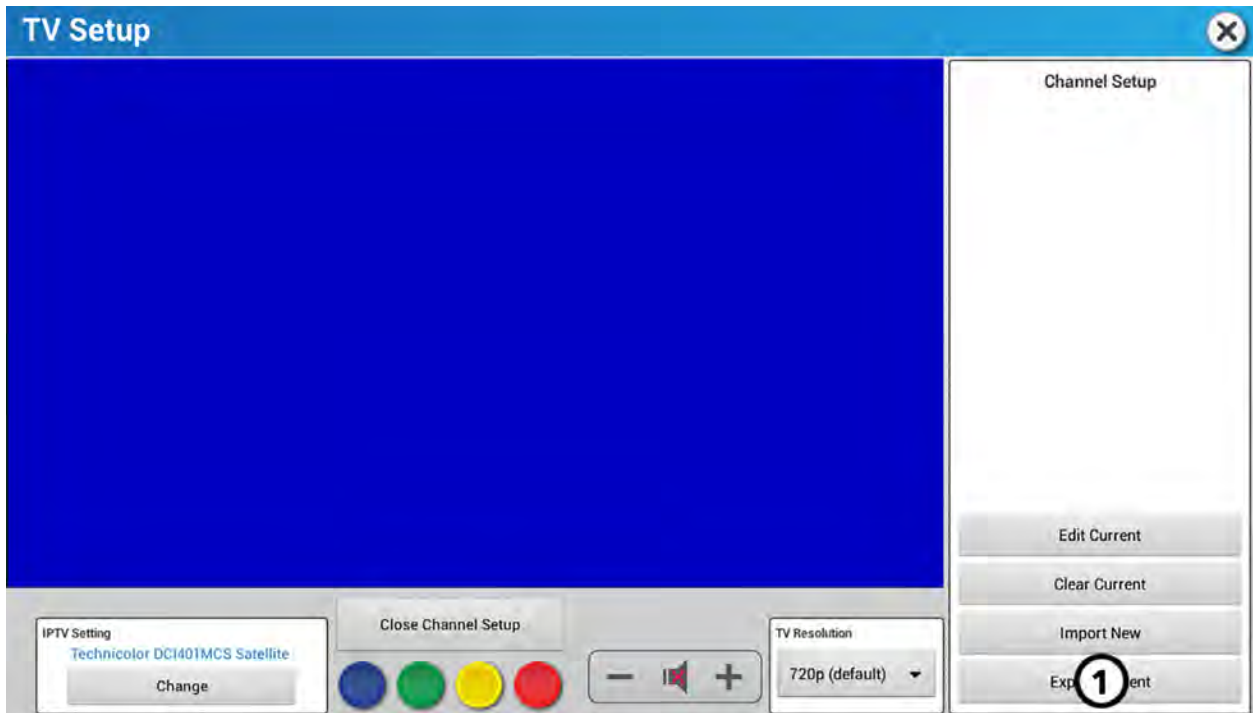

See [Import New](#) for directions about importing your channel list on the USB flash drive to other machines.

## Open IPTV



Open IPTV allows custom channel creation.

### 1. Tuner Type

The Open IPTV tuner type only shows when the console is configured for Open IPTV.

### 2. TV Setup

Press to access the Open IPTV **TV Setup** menu.

### 3. Custom Channel

- Input URL address - Enter each UDP address assigned to each channel.  
**NOTE:** The format should use `udp://@(IP Address: Port)`
- Create channel name

4. Press the checkmark to save the channel to the channel list.

### 5. Channel Table

URL address and channel name populate in a channel table.

6. Press the **X** to delete the selected channel.

### 7. Preview Channel

Press ► to open a separate window to preview the selected channel.

### 8. Import Channels

Import channel list from an inserted USB stick.

## **9. Export Channels**

Export channel list to an inserted USB stick.

## **10. Upload Channel List**

Uploads your channel list to Halo Fitness Cloud (if connected) and instantly to all units in the facility if units are connected to the internet.

## **11. Buffer Configuration**

Change the amount of buffered data to optimize video streaming.

# 8. Specifications

## Console Specifications

Console Screen Type:	LCD with integrated projected capacitive touch screen
LCD Touch Screen Size:	23.8 in. (60.5 cm) diagonal
LCD Touch Screen Power Requirement:	20.5 -25.5 VDC @ 3.5 A
Ports:	CSAFE: Type RJ45, interchangeable Network ready connection and Fitness Entertainment port (power compliant with FitLinxx CSAFE specification dated August 4, 2004: 4.75 VDC to 10 VDC; maximum current of 85 mA).
Headphone Jack:	3.5mm Stereo
Ambient Temperature Range (Operating)	10C - 40C (nominal 25C)
Temperature Range (Storage / Shipping Non- Operational)	-33 - 71C (key limiting item: LCD Touch Screen)
Humidity Range (Operating)	5% - 85% RH (nominal 40% RH, non-condensing)
Heart Rate Monitoring Systems:	<ul style="list-style-type: none"> <li>Patented Lifepulse™ digital contact heart rate and Polar® telemetry-compatible heart rate monitoring system</li> <li>Compatible with ANT+ and Bluetooth heart rate monitoring devices</li> </ul>
Heart Rate Goal, workout	<ul style="list-style-type: none"> <li>Minimum: 50 beats per minute</li> <li>Maximum: 210 beats per minute</li> </ul>
Speed Range:	Symbio Runner Treadmill: 0.5 - 16.0 MPH (0.8 - 25 KPH) in 0.1 increments
Incline Levels:	Symbio Runner Treadmill: 0 - 15% Symbio Incline Elliptical: 0 - 15
Resistance Levels:	Symbio Upright LifeCycle™ and Symbio Recumbent Cycle: 0-25 Symbio Upright SwitchCycle: 0 - 99 Symbio Incline Elliptical: 0-25
USB Device Charging:	Can be used in combination with Apple Lightning, Apple USB-C, Android USB-C, and Android micro USB cables to charge compatible devices.
Wireless Charging:	<ul style="list-style-type: none"> <li>Charging area: 50 mm x 80 mm (approximately 2 in. x 3 in.)</li> <li>Charging response time: less than 3 seconds</li> <li>Maximum output: 10 W</li> <li>Charging protocol compatibility: Qi Fast Charging</li> </ul>
Broadcast Receiver Capabilities:	NTSC/ATSC or PAL/DVB-T/DVB-T2 or NTSC/ISDB-T/DTMB (three separate tuners). NTSC/ISDB-T support Japan and Brazil versions of the ISDB standard including B-CAS and supports DTMB (or DMB-TH) for China. Additionally supports PAL-M and PAL-N (unique PAL encoding for Argentina, Brazil, Paraguay, and Uruguay where no digital broadcasting is available).
Cable / Satellite Receiver Capabilities:	QAM-B or DVB-C/DVB-S/DVB-S2 QAM-B includes Pro:Idiom™ decryption capabilities.
IPTV Receiver Capabilities:	Support Clear and Pro:Idiom™ encrypted IPTV using Multicast UDP and RTP protocols.

## Console Dimensions

	Physical Dimensions (Unboxed)
Depth	3.4 in / 8.6 cm
Width	22.76 in / 57.8 cm
Height	16.4 in / 41.6 cm
Weight	24 lbs. / 10.9 kg

# 9. Copyrights and Trademarks

## List of Copyrights and Trademarks

### Life Fitness

Life Fitness®, All Rights Reserved. Life Fitness is a registered trademark.

Discover™, FitPower™, Heart Rate+™, LFconnect™, Lifepulse™, Lifescape™, MaxBlox™, PowerMill™, SureStepSystem™, Swipe™ and Workout Landscape™ are trademarks of Life Fitness.

### Other

FitLinxx™ is a trademark of ActiveLinxx.

Bluetooth® is a registered trademark owned by Bluetooth SIG, Inc.

Polar® is a registered trademark of Polar Electro, Inc.

iPad®, iPhone®, iPod®, and Apple Watch® are registered trademarks of Apple Inc.

Android™ is a trademark of Google Inc. PM-038-13. (3.14)

Gym Wipes® is a registered trademark of The 2XL Corporation.

PureGreen 24™ is a trademark of Pure Green.

Qi® is a registered trademark of Wireless Power Consortium, Inc.

Samsung Galaxy Watch® Samsung, Galaxy S and Shop Samsung are all trademarks of Samsung Electronics Co. Ltd.

# 10. Warranty

## What is Covered

This Life Fitness commercial exercise equipment product is warranted to be free of all defects in material and workmanship.

## Who is Covered

The original purchaser or any person receiving the product as a gift from the original purchaser. Warranty will be voided on subsequent transfers.

## How Long It is Covered

All coverage is provided by specific Product according to the guidelines listed in Warranty Information.

## Who Pays Transportation and Insurance For Service

If the Product or any covered part must be returned to a service facility for repairs, We, Life Fitness, will pay all transportation and insurance charges for the first year. You are responsible for transportation and insurance charge after the first year.

## What We Will Do To Correct Covered Defects

We will ship to you any new or rebuilt replacement part or component, or at our option, replace the Product. Such replacement parts are warranted for the remaining portion of the original warranty period.

## What is Not Covered

Any failures or damage caused by unauthorized service, misuse, accident, negligence, improper assembly or installation, debris resulting from any construction activities in the Product's environment, rust or corrosion as a result of the Product's location, alterations or modifications without our written authorization or by failure on your part to use, operate and maintain the Product as set out in your Operation Manual ("Manual").

One type RJ45 interchangeable Network ready and Fitness Entertainment port is supplied with the Product. This port complies with the FitLinxx CSAFE specification dated August 4, 2004 stating: 4.75 VDC to 10 VDC; maximum current of 85 mA. Any Product damage caused by a load exceeding this FitLinxx CSAFE specification is not covered by warranty.

All terms of this warranty are void if this product is moved beyond the continental borders of the United States of America (excluding Alaska, Hawaii and Canada) and are then subject to the terms provided by that country's local authorized Life Fitness representative.

## What You Must Do

Retain proof of purchase. use, operate and maintain the Product as specified in the Manual; notify the place of purchase of any defect within 10 days after discovery of the defect; if instructed, return any defective part for replacement or, if necessary, the entire Product for repair. Life Fitness reserves the right to decide whether or not a product is to be returned for repair.

## How to Get Parts and Service

Refer to the Corporate Headquarters section of this manual for your local service contact information. Reference your name, address and the serial number of your Product (consoles and frames may have different serial numbers). They will tell you how to get a replacement part, or, if necessary, arrange for service where your Product is located.

## Exclusive Warranty

THIS LIMITED WARRANTY IS IN LIEU OF ALL OTHER WARRANTIES OF ANY KIND EITHER EXPRESSED OR IMPLIED, INCLUDING BUT NOT LIMITED TO THE IMPLIED WARRANTIES OF MERCHANTABILITY AND FITNESS FOR A PARTICULAR PURPOSE, AND ALL OTHER OBLIGATIONS OR LIABILITIES ON OUR PART. We neither assume nor authorize any person to assume for us any other obligation or liability concerning the sale of this Product. Under no circumstances shall we be liable under this warranty, or otherwise, of any damage to any person or property, including any lost profits or lost savings, for any special, indirect, secondary, incidental or consequential damages of any nature arising out of the use of or inability to use this Product. Some states do not allow the exclusion or limitation of implied warranties or of liability for incidental or consequential damages, so the above limitations or exclusions may not apply to you.

## **Changes in Warranty Not Authorized**

No one is authorized to change, modify or extend the terms of this limited warranty.

## **Effects of State Laws**

This warranty gives you specific legal rights, and you may have other rights which vary from state to state and country by country.

## **Terms of Warranty Coverage**

Please use the link below to access component warranty terms:

<http://lifefitness.com/warranties>



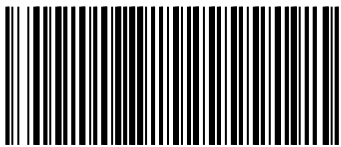

1022784-0001