

VR1 Leg Extension/Leg Curl

Owner's Manual



Part Number
13265-999-4 AD

CYBEX®

Table of Contents

Safety

Safety Guidelines and Practices.....	2
Anchoring Equipment.....	2
Facility Safety Precautions.....	2
User Safety Precautions.....	3
Warnings and Cautions.....	3
Label Placement.....	5

Assembly

Machine Specifications.....	6
Choosing and Preparing a Site.....	6
Environment.....	7
Verify parts list below.....	7
Tools Required.....	8
Assembly Procedure.....	8

Exercise

Intended Use.....	13
Instructions.....	13

Maintenance

Warnings.....	14
Daily Procedures.....	14
Weekly Procedures.....	15
Yearly Procedures.....	16
Cable Adjustment.....	16

Customer Service

Product Registration.....	19
Contacting Service.....	19
Ordering Parts.....	19
Return Material Authorization (RMA).....	19
Damaged Parts.....	20

Cybox® and the Cybox logo are registered trademarks of Cybox International, Inc. VR1® and its mark are registered trademarks of Cybox International, Inc.

DISCLAIMER: Cybox International, Inc. makes no representations or warranties regarding the contents of this manual. We reserve the right to revise this document at any time or to make changes to the product described within it without notice or obligation to notify any person of such revisions or changes.

© Copyright 2020, Life Fitness, LLC. All Rights Reserved. Life Fitness, Hammer Strength, Cybox, ICG and SCIFIT are registered trademarks of Life Fitness, LLC and its affiliated companies and subsidiaries. Brunswick and related trademarks used under license from Brunswick Corporation. Disclaimer: Images and specifications are current as of the date of publication and are subject to change.

Columbia Center III - 9525 West Bryn Mawr Ave, Rosemont, IL 60018 • 800-351-3737 • 847-288-3700 • FAX 800-216-8893

www.cyboxintl.com • 13265-999-4 AD • 2020

Safety

Safety Guidelines and Practices

TIP: Read the Owner's Manual carefully before assembling, servicing, or using the equipment. Owner must comply with all safety guidelines in this manual. It is also the owner's responsibility to instruct users on the safe and proper operation of the equipment and to properly display any and all warning labels and instructional placards. All users should read these labels and placards before using equipment.



WARNING: Serious injury or death could occur if the following safety precautions and instructions are not followed.



WARNING: This product can expose you to chemicals including Di-isobutyl Phthalate, which is known to the State of California to cause birth defects or other reproductive harm, and Antimony Trioxide, which is known to the State of California to cause cancer. For more information go to <http://www.P65Warnings.ca.gov>

Anchoring Equipment

Owner should not allow equipment to be used until it is properly anchored as described below.



WARNING: Anchoring equipment:

- To maximize stability and eliminate rocking, tipping, or falling over, equipment must be anchored to a solid, level surface, utilizing all anchoring holes provided.
- Fasteners must have a minimum of 500 lbs. tensile capacity. Cybex recommends .3/8" grade 2 bolts or better. A minimum pull force of 220 lbs/100 kgs is required for each anchor position.
- If leg frames do not contact surface, DO NOT pull down with anchors. Shim any leg or frame not in contact with surface using flat washers.
- Due to the wide variation of flooring on which machines may be anchored or installed, consult with a qualified and licensed contractor to ensure proper anchoring and installation.

Facility Safety Precautions

Do not allow anyone, including trainers, to use equipment in a manner other than that shown on the warning labels and instructional placards located on every machine.

Do not install equipment on an uneven surface. The solid, level surface should not deviate more than 1/8" over a 10' distance or as defined and required by local building and architectural codes.

It is the responsibility of the facility owner/owner of the equipment to ensure that there is appropriate clearance around each machine to allow for safe use and passage.

In compliance with the ADA (American Disabilities Act) there must be clear floor space of at least 30 by 48 inches and be served by an accessible route for at least one of each type of exercise equipment. If the clear space is enclosed on three sides (e.g., by walls or the equipment itself), the clear space must be 36 by 48 inches.

All other machines must have a clear floor space of 23" for all access point on the machine, unless shown in the Owner's Manual.

The dimensions stated in the assembly instructions of this manual include the maximum foot print (in use) dimensions.

All equipment should be used in a supervised, access-controlled area.

Do not allow equipment to be used by children 12 and under. Supervise disabled and children 13 and older.

The owner should ensure that regular inspection and maintenance checks as detailed in this manual are performed. Keep a log of all maintenance and repair activities.

Each day before use, the owner should inspect the equipment. If there are any loose or worn components such as belts, cables, grips, pulleys, or any missing, damaged labels, or placards, the owner should fix any deficiencies before they allow the equipment to be used.

Use only Cybex components to maintain and repair the equipment.

Display the Facility Safety Sign so it is visible and prominent.

User Safety Precautions

Owners must instruct users to DO the following:

- Follow all warning labels and instructional placards when using equipment.
- Insert weight pin completely before using selectorized equipment.
- Consult a physician prior to commencing an exercise program. If at any time during exercise you feel faint, dizzy or experience pain, stop and consult your physician.
- Use a spotter for Free Weight equipment.

Owners must instruct users to NOT DO the following:

- DO NOT pin weights on selectorized equipment in an elevated position or use the machine if found in this position
- DO NOT increase weight resistance on equipment by any means other than those provided by Cybex.
- DO NOT wear loose or dangling clothing or jewelry while using equipment. Stay clear of moving parts.
- DO NOT lean or pull on machine
- DO NOT use machine for support during stretching.
- DO NOT attach resistance straps, ropes or other means to equipment, except those provided by the manufacturer for intended use on the equipment.
- DO NOT exceed the maximum specified user weight.
- DO NOT use if equipment appears damaged or inoperable upon inspection
- DO NOT use if guards are missing or damaged.
- DO NOT remove any labeling from equipment.

Warnings and Cautions

Warning labels indicate a potentially hazardous situation that could result in serious injury or death if the precautions are not observed.

Caution labels indicate a potentially hazardous situation that could result in serious injury or damage to machine if the precautions are not observed.

⚠ WARNING

To minimize risk of serious injury:

Prior to use:

- Obtain a medical exam before beginning any exercise program.
- Obtain instruction before using.
- Read and understand warning labels. 
- Fully insert adjustment pins before using.
- Inspect machines and attachments before use. **DO NOT** use if the machine or attachments appear to be damaged. **DO NOT** attempt to fix broken or jammed machine or damaged attachments. Notify staff immediately.

During use:

- Use only as shown on instructional placard.
- Do not use for stretching and do not attach straps or other devices.
- Do not modify unit.
- Do not allow children 12 or younger to be on or near unit.
- Notify floor staff if weight plate is raised. **DO NOT USE.**
- Stop exercise if you feel faint, dizzy, or have pain.
- Use a spotter.

Do not remove this label. Replace if damaged or illegible.

DE000001-4 AB

⚠ CAUTION

To avoid injury, be sure pin is fully inserted into adjustment hole before use.

8500-025-4 B

⚠ CAUTION

Arm can fall when adjustment knob is pulled.

To avoid injury, support arm when adjusting and fully insert pin into adjustment hole before use.

4510-321-4 B

⚠ CAUTION

Pinch hazard.

Keep hands and fingers away when weight stack is elevated.

DE000005-4

Label Placement

The following diagram shows where each label is located.

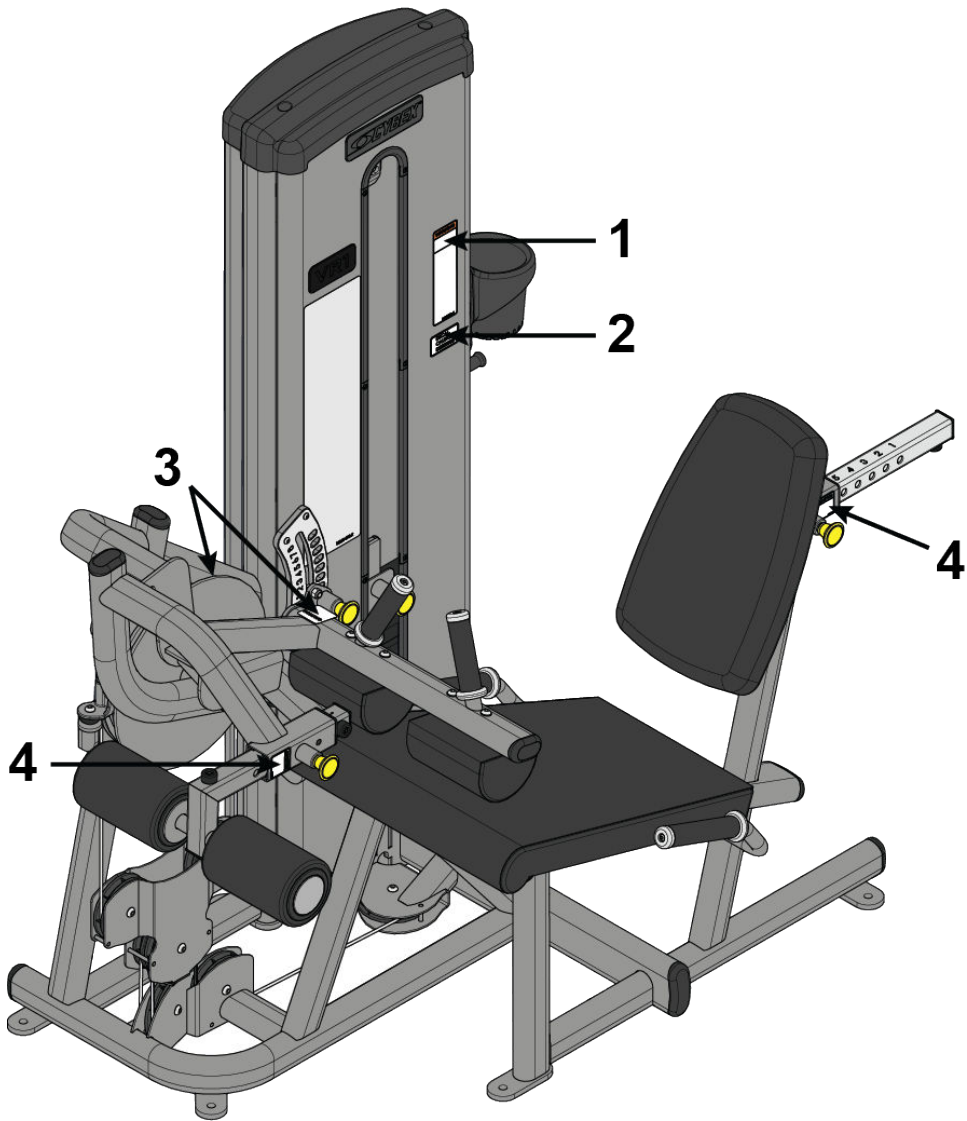

	Description	Qty
1	DE000001-X	1
2	DE000005-X	1
3	4510-321-X	2
4	8500-025-X	2

Assembly

Machine Specifications

Total Weight and Size: 13265 VR1 Leg Extension/Leg Curl Standard Stack

Weight	Machine Dimensions at Rest	Machine Dimensions in Use
437 Lbs	66" L × 41" W × 62" H	70" L × 41" W × 62" H
199 Kg	168 cm L × 104 cm W × 157 cm H	177 cm L × 104 cm W × 157 cm H

Total Weight and Size: 13265 VR1 Leg Extension/Leg Curl Light Stack

Weight	Machine Dimensions at Rest	Machine Dimensions in Use
392 Lbs	66" L × 41" W × 62" H	70" L × 41" W × 62" H
178 Kg	168 cm L × 104 cm W × 157 cm H	177 cm L × 104 cm W × 157 cm H

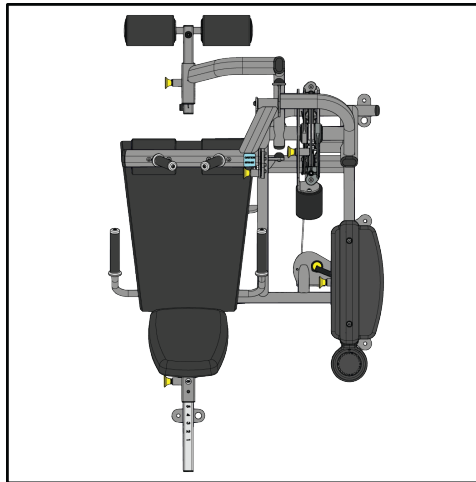

Maximum User Weight	Maximum Training Weight
300 lbs/135kg	152.5 lbs/69 kg

Choosing and Preparing a Site

Before assembling the unit, verify the chosen site meets the following criteria:

- Area is well lit and well ventilated.
- Surface is structurally sound and properly leveled.
- Free area for access to unit and emergency dismount. Minimum clearance is 23.6 inches (0.6 meters).
- Adjacent units may share the free area.

It is the responsibility of the facility owner/owner of the equipment to ensure that there is appropriate clearance around each machine to allow for safe use and passage.

In compliance with the ADA (American Disabilities Act) there must be clear floor space of at least 30 by 48 inches and be served by an accessible route for at least one of each type of exercise equipment. If the clear space is enclosed on three sides (e.g., by walls or the equipment itself), the clear space must be 36 by 48 inches.

All other machines must have a clear floor space of 23" for all access point on the machine, unless shown in the Owner's Manual.

Environment

Humidity and Static Electricity

The unit is designed to function normally in an environment with a relative humidity range of 30% to 75%. The unit can be shipped and stored in a relative humidity range of 10% to 90%.

Climatic dry air may cause static electricity. During workout, user may experience a shock due to build up of static electricity on the body and the discharge path of the unit. If static electricity is experienced, increase humidity to a comfortable level through the use of a humidifier.

Do not install, use or store the unit in an area of high humidity, such as in the vicinity of a steam room, sauna, indoor pool or outdoors. Exposure to extensive water vapor, chlorine and/or bromine could adversely affect other parts of the unit.

Temperature

The unit is designed to function normally in an environment with an ambient temperature range of 50° F (10° C) to 104° F (40° C). The unit can be shipped and stored in an environment with an ambient temperature range of 32° F (0° C) to 140° F (60° C).

Verify parts list below

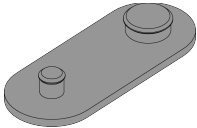
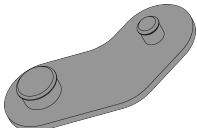
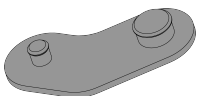
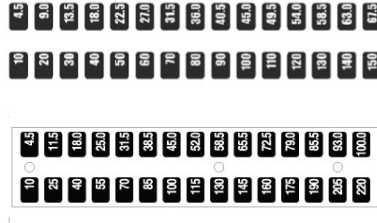
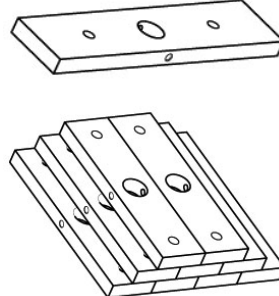
Qty	Part Number	Description	Diagram
5	13000-353	Foot Pad	
1	13000-354	Foot Pad	
1	13000-355	Foot Pad	
1 1	4800-557 13000-552	Decal, Weight Plate (10-150) (Light) Decal, Weight Plate (10-220) (Standard)	
1 9	4700-337 13000-030	Weight Stack Plate (Light) Weight Plate Pack (Light)	

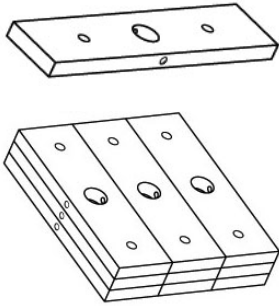
Qty	Part Number	Description	Diagram
1	4700-338	Weight Stack Plate (Standard)	
9	13000-034	Weight Plate Pack (Standard)	

Tools Required

- 7/32" Allen wrench
- 3/4" Socket wrench or Open end wrench
- Hammer
- 3/16" Pin punch

Assembly Procedure

Two people will be required for this procedure.

TIP: Read and understand all instructions thoroughly before assembling this unit. Check all items carefully. If there is damage, see the Customer Service section of this manual for proper procedure to return, replace, or reorder parts.

If machine CAN be moved without adding or removing weight stack

1. Two people will be required for this procedure
1. Move to desired location.
2. Remove shipping cones using a 3/4" socket or wrench.
3. Remove bolt from shipping cone with hammer. Recycle cone. 
4. Attach foot pads to each foot of frame.

Securely anchor machine to floor

Owner should not allow equipment to be used until it is properly anchored as described below.



WARNING: Anchoring equipment:

- To maximize stability and eliminate rocking, tipping, or falling over, equipment must be anchored to a solid, level surface, utilizing all anchoring holes provided.
- Fasteners must have a minimum of 500 lbs. tensile capacity. Cybex recommends .3/8" grade 2 bolts or better. A minimum pull force of 220 lbs/100 kgs is required for each anchor position.
- If leg frames do not contact surface, DO NOT pull down with anchors. Shim any leg or frame not in contact with surface using flat washers.
- Due to the wide variation of flooring on which machines may be anchored or installed, consult with a qualified and licensed contractor to ensure proper anchoring and installation.

Verify proper operation

If machine CANNOT be moved without adding or removing weight stack

1. Two people will be required for this procedure

1. Remove the two Button Head Socket Cap Screws (BHSCS) securing the top cap to the frame using a 7/32" Allen wrench.

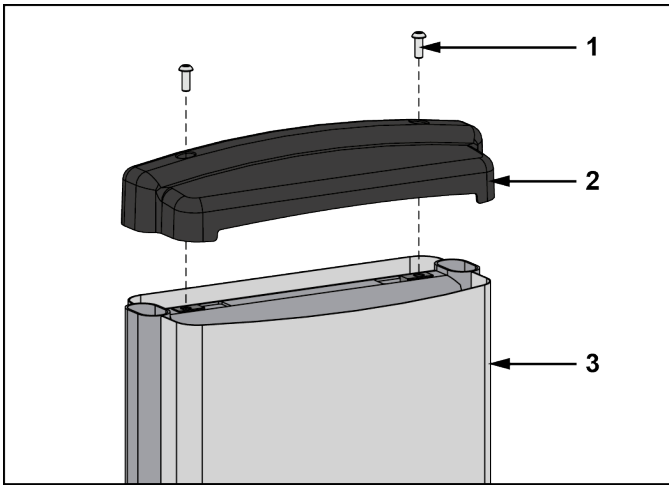

	Description	Qty.
1	BHSCS	2
2	Top cap	1
3	Shroud	1

2. Remove top cap and BHSCS.
3. Lift shroud up and out of machine.
4. Remove guide rod caps. Guide rod cap contains a compression spring that will fly if grasp is not released slowly. Slide spring loaded guide rod cap down guide rod until cap is clear of frame. Slowly release grasp of guide rod cap and remove.

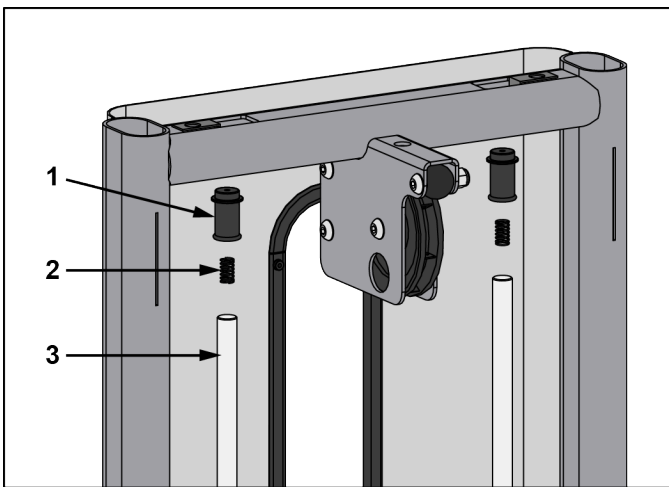

	Description	Qty.
1	Guide rod cap	2
2	Compression spring	2
3	Guide rod	2

5. Remove guide rod cap and springs.
6. Repeat procedure for opposite guide rods.
7. Remove spiral pin securing cable end to top weight using a 3/16" pin punch and hammer.

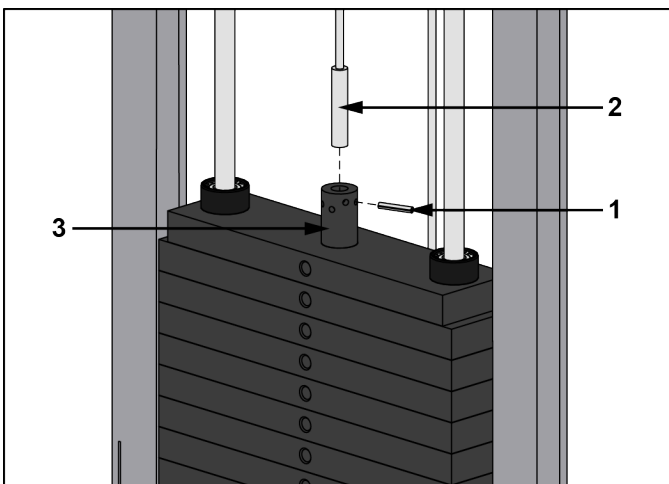

	Description	Qty.
1	Spiral pin	1
2	Cable	1
3	Top weight connector	1

8. Remove lifting post.
9. Remove weight plates.

10. Move to desired location.
11. Remove shipping cones using a 3/4" socket or wrench.
12. Remove bolt from shipping cone with hammer. Recycle cone. ♻️
13. Attach foot pads to each foot of frame.

Install weight plates

1. Lean guide rods slightly outward, away from machine, DO NOT put excessive pressure on guide rods, it will damage lower guide rod caps.
2. Wipe the entire length of the guide rods with a clean cloth.
3. Lubricate the guide rods with a light coating of medium weight oil.
4. Install each weight plate, one at a time, so wide edge of bushing faces upward (1) and narrow edge of bushing (2) faces downward.

Correct: Wide bushing edge upward

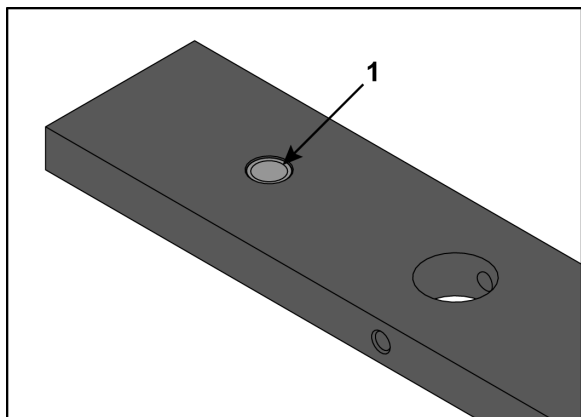

Incorrect: Narrow bushing edge downward.

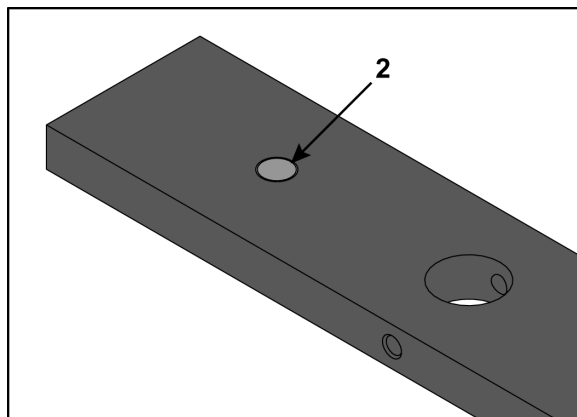

5. Install lifting post.
6. Install compression spring and top guide rod cap onto guide rod. Slide spring loaded top guide rod cap down guide rod until cap is clear of guide rod plate and install. Repeat for opposite side.

Apply weight plate decal

1. Peel off half of backing from weight plate decals, making sure that the decals remain attached to the front sheet.

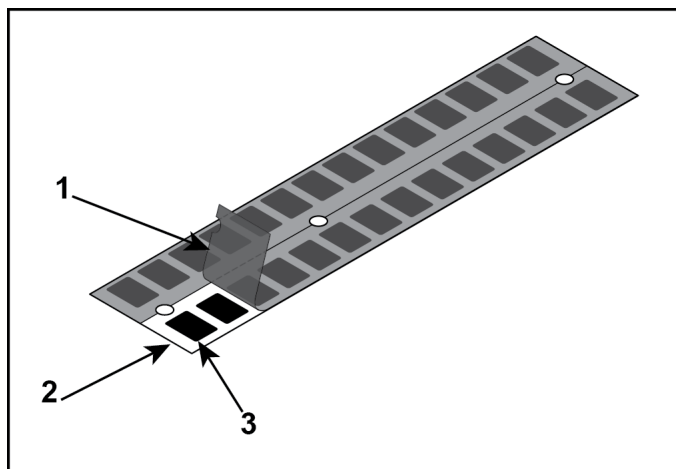

Item	Description	Qty
1	Backing	1
2	Front sheet	1
3	Weight decals	1

2. Place decals front sheet in the correct position on weight plates.
3. Insert a guide pin through each hole of the decals front sheet. A guide pin can be anything that fits through the weight stack hole, such as a weight stack selector pin.
4. Align decals and rub them onto weight plates.

- Remove front sheet, do not peel decals off of weight plates.

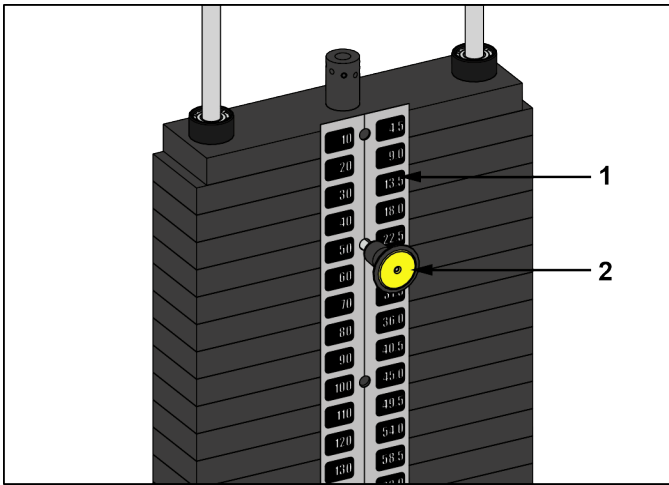

Item	Description	Qty
1	Weight plate decal	1
2	Weight stack selector pin	1

- Repeat above steps for other half of the weight plate decals.

Belt routing

- Verify belt is routed through top of pulley bracket and then route end of belt down to the top weight.
- Lift top weight and verify that the position of the belt clamp (on the top weight) is aligned properly with the top pulley bracket.
- Slide belt through slot in belt clamp.
- Verify belt and insert are installed properly. Do not install the insert backwards.

Correct belt routing

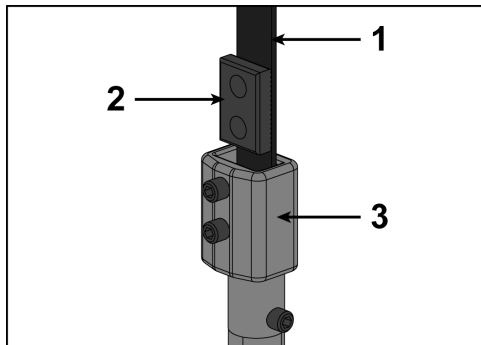

Incorrect belt routing

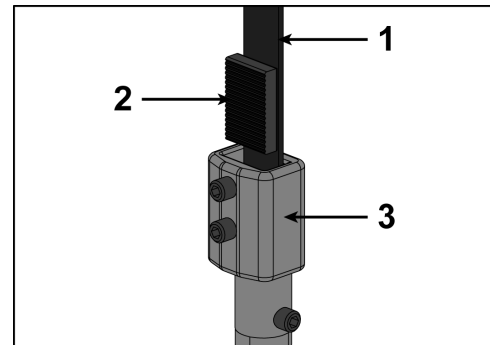

Item	Description	Qty.
1	Belt	1
2	Insert	1
3	Belt clamp	1

- Pull belt tight and secure belt to clamp with set screws.
- Torque set screws 300-350 lb-in.
- Turn the Increment Weight Adjusting Knob to select 0 lbs or 0 kg.
- Place weight stack pin in each plate to verify proper installation.
- Simulate normal operation by lifting top weight up and down without selecting any resistance.
- Verify that the belt is moving smoothly and is routed straight from the top pulley bracket to the top weight belt clamp.

Install back shroud

- Place shroud into position.
- Starting at the bottom replace the two BHSCS to secure bottom support bracket to the shroud.
- Install but do not tighten remaining BHSCS securing shroud.

4. Tighten all BHSCS.

Securely anchor machine to floor

Owner should not allow equipment to be used until it is properly anchored as described below.



WARNING: Anchoring equipment:

- To maximize stability and eliminate rocking, tipping, or falling over, equipment must be anchored to a solid, level surface, utilizing all anchoring holes provided.
- Fasteners must have a minimum of 500 lbs. tensile capacity. Cybex recommends .3/8" grade 2 bolts or better. A minimum pull force of 220 lbs/100 kgs is required for each anchor position.
- If leg frames do not contact surface, DO NOT pull down with anchors. Shim any leg or frame not in contact with surface using flat washers.
- Due to the wide variation of flooring on which machines may be anchored or installed, consult with a qualified and licensed contractor to ensure proper anchoring and installation.

Verify proper operation

Exercise

Intended Use



The intended commercial use of this machine is to aid exercise and improve general physical fitness.

Instructions

TIP: Read and understand all instructions and warnings prior to using this machine in the Safety section of the Owner's Manual.

CAUTION: Use only in manner depicted. To avoid serious injury, use equipment only as describe in placards located on each machine.

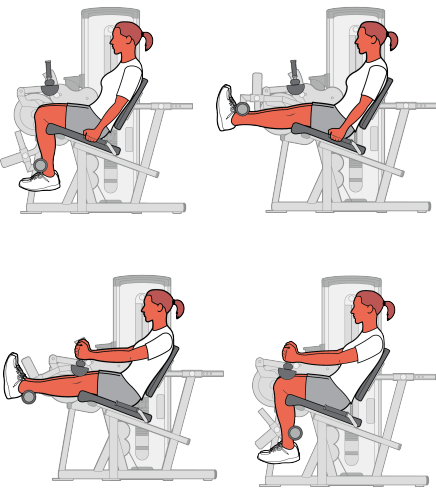
All adjustment points on the machine have yellow handles or knobs.

Set Up	Motion	Muscles Used
<ul style="list-style-type: none"> Adjust back pad so when seated, knees align with machine's axis of rotation. Leg Extension - Comfortably position leg pad and apply light pressure. Leg Curl - Adjust leg pad comfortably behind ankles. Leg Curl - Lower thigh pad to a snug position. Grasp handles and stabilize body. 	<ul style="list-style-type: none"> Leg Extension - Push forward and up against pad until legs are straight. Leg Curl - Pull down and back against pad until feet are below seat. 	<ul style="list-style-type: none"> Leg Extension - Quadriceps Leg Curl - Hamstrings
		

Maintenance

All preventive maintenance activities must be performed on a regular basis. Performing routine preventive maintenance actions can aid in providing safe, trouble-free operation of all Cybex equipment.

Cybex is not responsible for performing regular inspection and maintenance actions for your machines. Instruct all personnel in equipment inspection and maintenance actions and also in accident reporting and recording. Cybex representatives are available to answer any questions that you may have.

Warnings

TIP: Read all warnings in this chapter.



WARNING: For maintenance, service and repair:

- Must be performed by trained service personnel only
- Use only replacement parts.



WARNING: Equipment hazard.

To avoid serious injury or death replace worn or damaged components immediately and keep the equipment out of use until repair is completed.



WARNING: The safety level of the equipment can be maintained only if the equipment is examined regularly for damage and wear.

Daily Procedures

When using strong cleaning agents such as rubbing alcohol or bleach, it is advisable to test first in an inconspicuous area. Other cleaning agents may contain harsh or unknown solvents and are subject to formula changes by the product manufacturer without notice. Should you desire to use other cleaning agents, carefully try them in an inconspicuous area to determine potential damage to the material. Never use harsh solvents or cleaners which are intended for industrial applications. To clean stained or soiled areas, a soft white cloth is recommended. Avoid use of paper towels.

Cleaning products may be harmful/irritating to your skin, eyes, etc. Use protective gloves and eye protection. **Do Not** inhale or swallow any cleaning product. Protect surrounding area/clothing from exposure. Use in well ventilated area. Follow all product manufacturer's warnings. Cybex and its vendors cannot be held responsible for damage or injuries resulting from the use or misuse of cleaning products.

Clean Upholstery

If	Then
Light Soiling	<ol style="list-style-type: none">1. Prepare a solution of 10% household liquid soap and warm water.2. Apply with a soft damp cloth.3. If necessary, apply a solution of liquid cleanser with a soft bristle brush.4. Dampen a clean soft cloth in water and wipe residue away.
More Difficult Stains	<ol style="list-style-type: none">1. Prepare a solution of 10% household bleach (sodium hypochlorite) and 90% water. Dampen a soft white cloth in the solution.2. Rub gently on the stained area.3. Dampen a clean soft cloth in water and rinse area.4. If stains are still present, a full strength household bleach may be used. Allow bleach to puddle on the affected area or apply with a bleached-soaked cloth for approximately 30 minutes. Dampen a clean soft cloth in water, and rinse area to remove any remaining bleach concentration.
More Difficult Stains (Alternative Method)	<ol style="list-style-type: none">1. Dampen a soft white cloth with rubbing alcohol.2. Gently rub stained area.3. Dampen a clean soft cloth in water and rinse area.

If	Then
Restoring Luster	<ol style="list-style-type: none"> 1. Apply a light coat of furniture wax for 30 seconds. 2. Lightly rub area using a clean white cloth.

Clean Frames

Wipe down all frames using a mild solution of warm water and car wash soap. Be sure to dry thoroughly. **AVOID** acid or chlorine based cleaners and also cleaners containing abrasives as these could scratch or damage the equipment.

Clean Chrome

Clean chrome tubes, first using chrome polish and then using a car wax seal. Neutral cleaners with a pH between 5.5 and 8.5 are recommended. Be sure to dry thoroughly. **AVOID** acid or chlorine based cleaners and also cleaners containing abrasives as these could scratch or damage the equipment.

Guidelines for cleaning front panel:

Use clean soft cloths or sponges for application of cleaners and again for washing and rinsing. Follow up each application with warm water rinse.

- **DO NOT** use abrasives or high alkaline cleaners.
- **DO NOT** leave cleaners on for long periods, wash immediately.
- **DO NOT** apply cleaners in direct sunlight or at elevated temperatures.
- **DO NOT** use scrapers, squeegees, or razors.
- **DO NOT** clean with gasoline.

Compatible Cleaners and Detergents:

- Formula 409
- Top Job
- Joy
- Palmolive
- Windex with Ammonia D

To Minimize Fine or Hairline Scratches:

Mild automotive polish applied and removed with a soft clean cloth will help fill scratches.

Suggested Polishes:

- Johnson Paste Wax
- Mirror Glaze #10 Plastic Polish (by Mirror Bright Polish Co.)
- Novus Plastics Polish #1, #2 (By Novus Inc.)

Weekly Procedures

Inspect All Nuts and Bolts

Tighten all loose nuts and bolts as required.





WARNING: Equipment hazard.

To avoid serious injury or death replace worn or damaged components immediately and keep the equipment out of use until repair is completed.

Inspect Cables

Inspect all cables for wear or damage and proper tension. When inspecting cables, run fingers on the cable, paying particular attention to bends and attachment points.

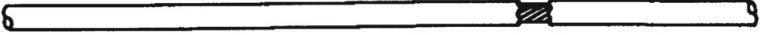
The following conditions may indicate a worn cable:

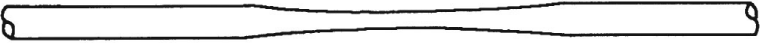
Condition of Cable	Diagram
A tear or crack in the cable sheath that exposes the cable	
A kink in the cable	
A curled sheath	
Necking - A stretched cable sheath	

Inspect Other Items

Inspect other items for proper operation, damage, or wear.

Inspection	Action
Inspect grips for looseness or wear.	Replace all loose or worn grips immediately.
Inspect all labeling for readability, including instructional placards, warning and caution decals.	Replace all worn labeling immediately.
Inspect all weight stacks for proper alignment and operation.	Correct all improper alignment and operation issues immediately.
Inspect guide rods for lubrication.	Wipe Weight Stack Guide Rods clean over entire length. Lubricate with a light coat of medium weight automotive engine oil.

Yearly Procedures

Replace all cables and belts annually

Cable Adjustment

Tools Required

- 9/16" Wrench (2)
- Hammer
- 3/16" Pin punch

Four types of cable tension adjustment are used on Cybex Strength Systems:

Jam Nut Adjustment

This type of adjustment uses a jam nut and a tension adjustment nut at the cable cam end as the primary adjustment. The other end of the cable usually contains a roll pin adjustment.

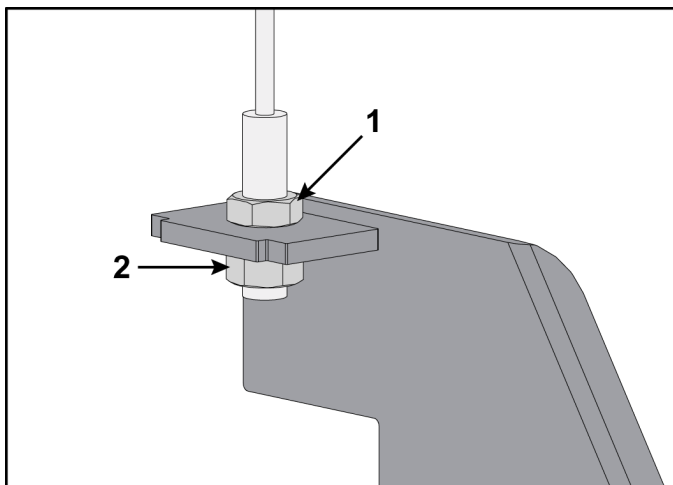

Item	Description	Qty.
1	Jam nut	1
2	Tension adjustment nut	1

Rod End Adjustment

This type of adjustment uses a socket head cap screw (SHCS) securing a cable rod end bearing to the machine. Primary adjustment is by turning the rod end bearing. The other end of the cable usually contains a roll pin cable adjustment.

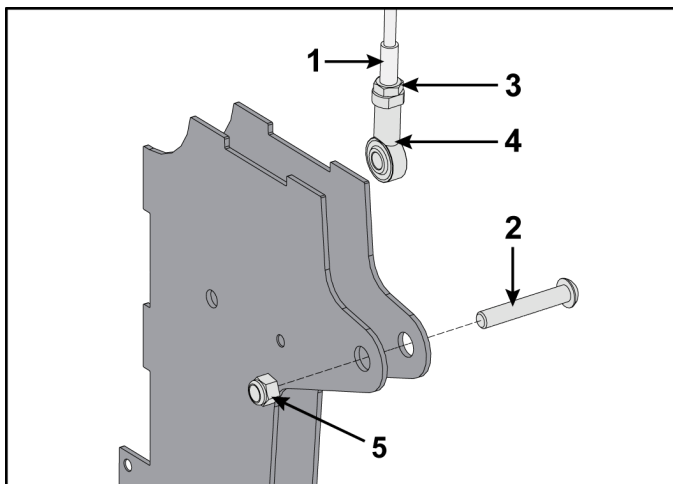

Item	Description	Qty.
1	Cable end	1
2	SHCS	1
3	Jam nut	1
4	Cable rod end bearing	1
5	Nylon locknut	1

Roll Pin Adjustment

This type of adjustment uses a roll pin and series of holes in the weight stack top weight connector.

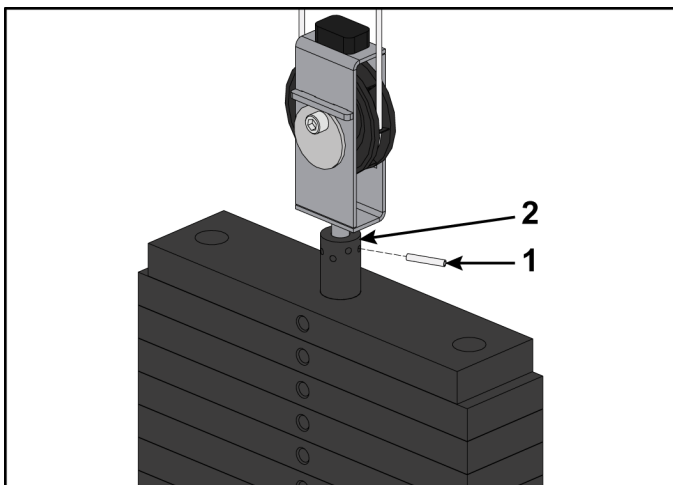

Item	Description	Qty.
1	Roll pin	1
2	Top weight connector	1

Cam End Adjustment

This type of adjustment uses an adjustment bolt on the pulley bracket. Loosen nut and rotate cam bolt to adjust cable.

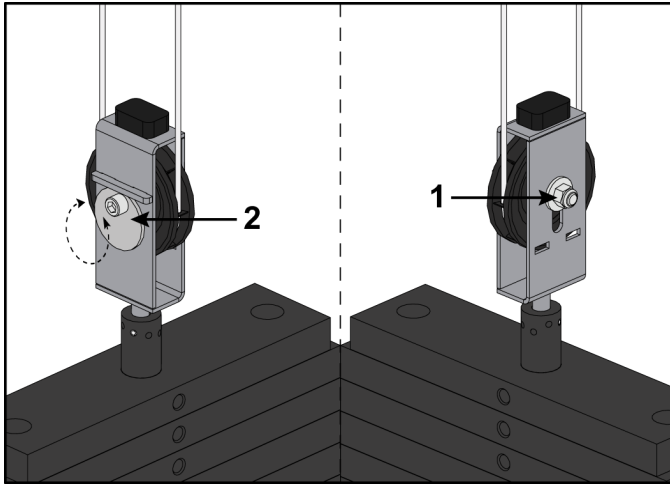

Item	Description	Qty.
1	Nut	1
2	Cam bolt adjustment	1

Customer Service

Product Registration

To register product do the following:

1. Visit www.cybexintl.com.
2. Locate Product Registration in the Support section.
3. Fill out form completely.
4. Click the **Submit** button to register product.

Contacting Service

Hours of phone service are Monday through Friday from 8:30 a.m. to 6:00 p.m. Eastern Standard Time.

For Cybex customers living in the USA, contact Cybex Customer Service at 1-888-462-9239.

For Cybex customers living outside the USA, contact Cybex Customer Service at 1-508-533-4300 or fax 1-508-533-5183. Email address internationaltechhelp@cybexintl.com

Find information on the web at www.cybexintl.com.

To contact us online go to www.cybexintl.com.

Ordering Parts

To order parts online go to www.cybexintl.com.

To speak with a customer service representative, call 800-351-3737 (for customers living within the USA) or 847-288-3700 (for customers outside the USA).

The following information located on the serial number decal will assist our Cybex representatives in serving you.

- Unit Serial Number, Product Name and Model Number
- Part Description and Part Number if you have it. All parts can be found on the web at www.cybexintl.com
- Shipping Address
- Contact Name
- Include a description of the problem.

In addition to your shipping address and contact name, your account number is helpful but not required. You may also fax orders to 800-216-8893.

Return Material Authorization (RMA)

The Return Material Authorization (RMA) system is used when returning material for placement, repair or credit. The system assures that returned materials are properly handled and analyzed. Follow the following procedures carefully.

Contact your authorized Cybex dealer on all warranty-related matters. Your local Cybex dealer will request a RMA from Cybex, if applicable. Under no circumstances will defective parts or equipment be accepted by Cybex without proper RMA and an Automated Return Service (ARS) label.

Please contact [Cybex Customer Service](#) for the return of any item that is defective.

Provide the technician with a detailed description of the problem you are having or the defect in the item you wish to return. Provide the model and serial number of your Cybex equipment.

At Cybex's discretion, the technician may request that you return the problem part(s) to Cybex for evaluation and repair or replacement. The technician will assign you a RMA number and will send you an ARS label. The ARS label and the RMA numbers must be clearly displayed on the outside of the package that contains the item(s) to be returned. Include the description of the problem, the serial number of the equipment and the name and address of the owner in the package along with the part(s).

Merchandise returned without an RMA number on the outside of the package or shipments sent COD will not be accepted by the Cybex receiving department.

Damaged Parts

Materials damaged in shipment should not be returned for credit. Shipping damages are the responsibility of the carrier (UPS, Federal Express, trucking companies, etc.)

Apparent Damage

Upon receipt of your shipment, check all items carefully. Any damage seen with a visual check must be noted on the freight bill and signed by the carrier's agent. Failure to do so will result in the carrier's refusal to honor your damage claim. The carrier will provide you with the required forms for filing such claims.

Concealed Damage

Damage not seen with a visual check upon receipt of a shipment but noticed later must be reported to the carrier as soon as possible. Upon discovery of the damage, a written or phone request to the carrier asking them to perform an inspection of the materials must be made within ten days of the delivery date. Keep all shipping containers and packing materials as they will be needed in the inspection process. The carrier will provide you with an inspection report and the necessary forms for filing a concealed damage claim. Concealed damage claim is the carrier's responsibility.



Columbia Center III - 9525 West Bryn Mawr Ave, Rosemont, IL 60018 • 800-351-3737 • 847-288-3700 • FAX 800-216-8893

www.cybexintl.com