

Heavy Duty NX / iD Add-Ons

Owner's Manual

HDW-SQST, HDW-HR, HDW-PR, HDW-HHCR, HDW-PHCR, HDW-PPCR, ELT-HR, ELT-PR, ELT-HHCR, ELT-PHCR, ELT-PPCR



Corporate Headquarters

Columbia Centre III, 9525 Bryn Mawr Avenue, Rosemont, IL 60018 • U.S.A.
847.288.3300 • FAX: 847.288.3703
Service phone number: 800.351.3737 (toll-free within U.S.A., Canada)
Global Website: www.lifefitness.com

International Offices

AMERICAS

North America

Life Fitness, LLC

Columbia Centre III
9525 Bryn Mawr Avenue
Rosemont, IL 60018 U.S.A.
Telephone: (847) 288 3300
Service Email:
customersupport@lifefitness.com
Sales/Marketing Email:
commercialsales@lifefitness.com

Brazil

Life Fitness Brasil

Av. Rebouças, 2315
Pinheiros
São Paulo, SP 05401-300
BRAZIL
SAC: 0800 773 8282 option 2
Telephone: +55 (11) 3095 5200 option 2
Service Email: suportebr@lifefitness.com
Sales/Marketing Email:
vendasbr@lifefitness.com

Latin America and Caribbean*

Life Fitness, LLC

Columbia Centre III
9525 Bryn Mawr Avenue
Rosemont, IL 60018 U.S.A.
Telephone: (847) 288 3300
Service Email:
customersupport@lifefitness.com
Sales/Marketing Email:
commercialsales@lifefitness.com

EUROPE, MIDDLE EAST, and AFRICA (EMEA)

Belgium, Netherlands, and Luxemburg

Life Fitness Atlantic BV

Bijdorpplein 25-31
2992 LB Barendrecht
THE NETHERLANDS
+3118064666
Service Email:
service.benelux@lifefitness.com
Sales/Marketing Email:
marketing.benelux@lifefitness.com

United Kingdom

Life Fitness UK LTD

Unit 109^a
Lancaster Way Business Park
Ely, Cambs, CB6 3NX
Telephone: General Office (+44)
1353.666017
Customer Support (+44) 1353.665507
Service Email: uk.support@lifefitness.com
Sales/Marketing Email: life@lifefitness.com

Germany, Austria, and Switzerland

Life Fitness Europe GMBH

Neuhofweg 9
85716 Unterschleißheim
GERMANY
Telephone:
+49 (0) 89 / 31775166 Germany
+43 (0) 1 / 6157198 Austria
+41 (0) 848 / 000901 Switzerland
Service Email:
kundendienst@lifefitness.com
Sales/Marketing Email:
vertrieb@lifefitness.com

Spain

Life Fitness IBERIA

C/Frederic Mompou 5,1^a^a
08960 Sant Just Desvern Barcelona
SPAIN
Telephone: (+34) 93.672.4660
Service Email:
servicio.tecnico@lifefitness.com
Sales/Marketing Email:
info.iberia@lifefitness.com

All Other EMEA Countries and Distributor Business EMEA*

Life Fitness Atlantic BV

Bijdorpplein 25-31
2992 LB Barendrecht
THE NETHERLANDS
+3118064666
Service Email:
emeaservicesupport@lifefitness.com

ASIA PACIFIC (AP)

Japan

Life Fitness Japan, Ltd

4-17-33 Minami Aoyama 1F/B1F
Minato-ku - Tokyo 107-0062
Japan
Telephone: (+81) 0120.114.482
Fax: (+81) 03-5770-5059
Service Email: service.lfj@lifefitness.com
Sales/Marketing Email:
sales@lifefitnessjapan.com

Hong Kong

Life Fitness Asia Pacific LTD

26/F, Global Trade Square
21 Wong Chuk Hang Road
Wong Chuk Hang
Hong Kong
Telephone: (+852) 25756262
Fax: (+852) 25756894
Service Email: service.hk@lifefitness.com
Sales/Marketing Email:
marketing.hk.asia@lifefitness.com

All Other Asia Pacific countries and distributor business Asia Pacific*

Life Fitness Asia Pacific LTD

26/F, Global Trade Square
21 Wong Chuk Hang Road
Wong Chuk Hang
Hong Kong
Telephone: (+852) 25756262
Fax: (+852) 25756894
Service Email: service.ap@lifefitness.com
Sales/Marketing Email:
marketing.hk.asia@lifefitness.com

*Also check www.lifefitness.com for local representation or distributor/dealer

User and Service Documents Link

<https://fn.fit/KnowledgeBase>

<https://fn.fit/SupportDocuments>

Additional information is available online using the links above.

تتوفر معلومات إضافية على الإنترنت باستخدام الرابط أعلاه.

点击上面的链接可在线获取更多信息。

Flere oplysninger er tilgængelige online gennem linket ovenfor.

Bijkomende informatie is online beschikbaar via bovenstaande link.

Vous trouverez plus d'informations en ligne à l'aide du lien ci-dessus.

Zusätzliche Informationen finden Sie online über den oben angegebenen Link.

Ulteriori informazioni sono disponibili online utilizzando il link sopra riportato.

追加情報は上記リンクを使用してオンラインで利用可能です。

상기 링크를 통해 온라인에서 추가 정보를 볼 수 있습니다.

Informações adicionais estão disponíveis on-line, através do link acima.

Дополнительная информация доступна в интернете по ссылке, указанной выше.

Mediante el enlace anterior podrá acceder a información adicional en línea.

Ytterligare information finns online genom att använda länken ovan.

İnternet üzerinden daha fazla bilgi edinmek için yukarıdaki bağlantıyı kullanabilirsiniz.

هناك معلومات إضافية متاحة على الإنترنت باستخدام الرابط أعلاه.

Informazio osagarria eskuragarri dago goiko estekaren bidez.

Допълнителна информация можете да намерите онлайн, като използвате връзката по-горе.

Mitjançant l'enllaç anterior podreu accedir a informació addicional en línia.

使用上面的連結線上提供額外資訊。

Dodatne informacije možete pronaći na internetu sljedeći vezu iznad.

ከላይ የተመጠውን አገናኝ(ሊንክ) በመጠቀም መረጃዎች አንላይን ያገኛሉ።

Lisätietoja on saatavissa verkosta käyttämällä yllä olevaa linkkiä.

Wubetumi anya nsem afoforo aka ho wa websait so denam asem a ewa atifi ho a wubemia so so.

Πρόσθετες πληροφορίες είναι διαθέσιμες online χρησιμοποιώντας το σύνδεσμο παραπάνω.

מידע נוסף אפשר לקבל באינטרנט באמצעות הקישור לעיל.

További információ elérhető online, a fenti hivatkozás segítségével.

Viðbótarupplýsingar eru fáanlegar á netinu með því að smella á tengilinn hér fyrir ofan.

Plus indicium per superum situm potes invenire.

മുകളിലുള്ള ലിങ്ക് ഉപയോഗിച്ച് ഓൺലൈനിൽ കൂടുതൽ വിവരങ്ങൾ ലഭ്യമാണ്.

Ytterligere informasjon er tilgjengelig på nettet via linken ovenfor.

Dodatkowe informacje są dostępne online pod powyższym odnośnikiem.

Informações adicionais estão disponíveis online a usar o link acima.

Informații suplimentare sunt disponibile online, utilizând link-ul de mai sus.

Dodatne informacije dostupne su na mreži putem gornjeg linka.

Ďalšie informácie sú dostupné online na vyššie uvedenom odkaze.

Table of Contents

Safety

Safety Information.....	4
Product Labels.....	6
Label Locations.....	7

Assembly

Component and Hardware List.....	11
Tools Required.....	16
Assembly Procedure.....	17

Maintenance Procedures

Maintenance Schedule.....	45
---------------------------	----

Warranty

What is Covered.....	47
Who is Covered.....	47
Who Pays Transportation and Insurance For Service.....	47
What We Will Do To Correct Covered Defects.....	47
What is Not Covered.....	47
Owner's Manual.....	47
Exclusive Warranty.....	47
Changes in Warranty Not Authorized.....	47
Effects of State Laws.....	47
Warranty Coverage.....	47
How to Obtain Product Service.....	48

Life Fitness® is a registered trademark.

Gym Wipes® is a registered trademark of the 2XL Corporation. PureGreen 24 is a trademark of Pure Green.

© Copyright 2024, Life Fitness, LLC. All Rights Reserved. Life Fitness, Hammer Strength, Cybex, ICG and SCIFIT are registered trademarks of Life Fitness, LLC and its affiliated companies and subsidiaries. Disclaimer: Images and specifications are current as of the date of publication and are subject to change.

Columbia Center III - 9525 Bryn Mawr Ave., Rosemont, IL 60018 • 847-288-3300 •
www.lifefitness.com • 1020648-0001 AF • 2024

1. Safety

Safety Information

It is the sole responsibility of the purchaser of Life Fitness products to read the owner's manual and warning labels and instruct all individuals, whether they are the end user or supervising personnel, on proper usage of the equipment.

UNDERSTANDING EACH AND EVERY WARNING TO THE FULLEST IS IMPORTANT. IF ANY OF THESE WARNINGS ARE UNCLEAR, CONTACT Life Fitness CUSTOMER SERVICE IMMEDIATELY AT 1-800-351-3737.

This equipment is categorized as class S per EN ISO 20957-1. As such this equipment is only intended for commercial, institutional and/or studio facilities. It is not intended for home use. Contact Life Fitness with any questions regarding this classification.

It is recommended that all users of Life Fitness exercise equipment be informed of the following information prior to use.

Operating Warnings

 **WARNING:** This product can expose you to chemicals including Methyl Isobutyl Ketone, which is known to the State of California to cause cancer and birth defects or other reproductive harm. For more information go to <http://www.P65Warnings.ca.gov>

- Life Fitness does not warrant nor guarantee that component parts used in the manufacture of products offered under the Life Fitness are latex-free. Users of these products must take all necessary precautions to prevent accidental contact that could lead to an adverse latex reaction.
- It is the purchaser's sole responsibility to properly instruct its end users and supervising personnel as to the proper operating procedures of all equipment.
- This equipment is not intended for use by children. Keep children under the age of 14 away from the machine.
- Do not allow users to wear loose fitting clothing or jewelry while using equipment. It is also recommended to have users secure long hair back and up to avoid contact with moving parts.
- All bystanders must stay clear of all users, moving parts and attached accessories and components while machine is in operation.

Access Control

- Life Fitness recommends that all commercial fitness equipment be used in a supervised area. It is recommended that the equipment be located in an access controlled area. Control is the responsibility of the facility owner.

Installation

- Life Fitness requires that all equipment be secured to a solid, level surface to stabilize it and eliminate rocking or tipping over. This must be performed by a licensed contractor. See [Bolt to Floor Guide](#) for installation procedure.
- Life Fitness requires that all Athletic Racks be secured to the floor when used with body weight strap training devices to stabilize and eliminate rocking or tripping over. If necessary, please contact [Customer Support Services](#) for any questions.

Proper Usage

- Do not use any equipment in any way other than as designed or intended by the manufacturer. It is imperative that Life Fitness equipment is used properly to avoid injury.
- Injuries may result if exercising improperly or excessively. It is recommended that all individuals consult a physician prior to commencing an exercise program. If at any time during exercise you feel faint, dizzy or experience pain, STOP EXERCISING and consult your physician.
- Keep body parts (hands, feet, hair, etc.), clothing and jewelry away from moving parts to avoid injury.

Inspection

- Before use, examine all accessories approved for use with the Life Fitness equipment for damage or wear.
- DO NOT attempt to use or repair any accessory approved for use with the equipment which appears to be damaged or worn.
- DO NOT use or permit use of any equipment that is damaged and/or has worn or broken parts. For all Life Fitness equipment, use only replacement parts supplied by Life Fitness.
- Maintain labels and name plates - Do not remove labels for any reason. They contain important information. If unreadable or missing, contact Life Fitness customer service for a replacement.

- Equipment Maintenance - Preventative maintenance is the key to smooth operating equipment as well as to keep your liability to a minimum. Equipment needs to be inspected at regular intervals.
- Ensure that any person(s) making adjustments or performing maintenance or repair of any kind is qualified to do so. Life Fitness will provide service and maintenance training at our corporate facility upon request or in the field if proper arrangements are made.

Plate Loaded, Free Weight, and Body Weight Systems

- If the unit is equipped with weight rods, use only Olympic style weight plates (2.0" bore) for training weight. Do not use dumbbells or any means other than those stated to increase weight resistance - See machine specific section for more information.
- Always utilize weight plate retention devices such as straps, clamps or pins.
- Only add weight plates up to the load limits of the unit. Make sure all weight plates are completely placed on the weight rod.
- Never exceed the load rating for any plate loaded station, body weight station, bench or other free weight device; including specific weight rod and band peg limits. See machine specifications for load limit information.
- Contact a Life Fitness representative with any questions regarding proper weights and loading.

Warnings and Cautions

- Warning labels indicate a potentially hazardous situation that could result in serious injury or death if the precautions are not observed.
- Caution labels indicate a potentially hazardous situation that could result in serious injury or damage to machine if the precautions are not observed.
- Contact [Customer Support Services](#) to replace any worn or damaged labels.

Product Labels

Max Training, 405 LB

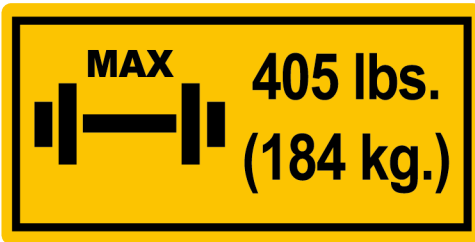

Max Training, 495 LB



Max Capacity, 680 LB



Max Capacity, 1485 LB



Pinch Hazard



Lightning Arm Assembly

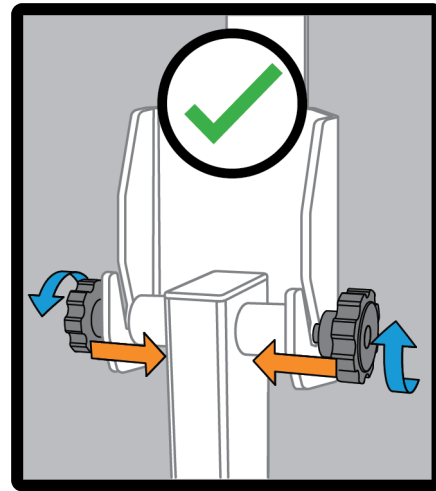

Serial Number



Stability Rack Attachment

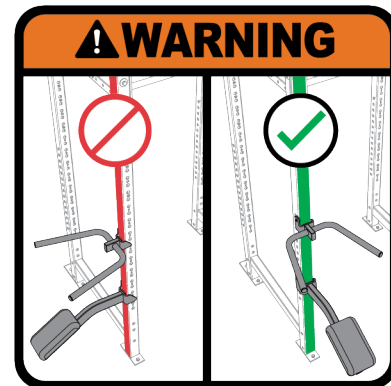

Label Locations

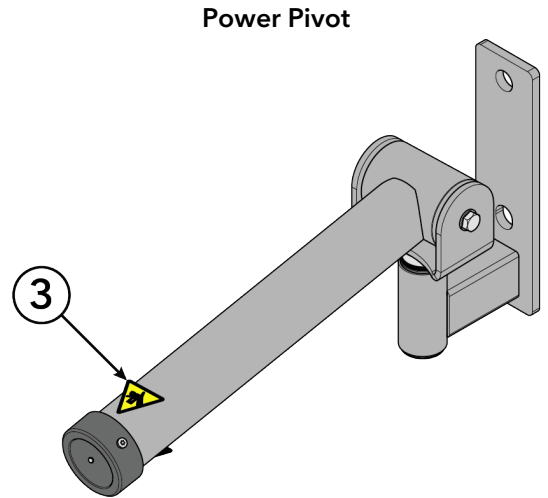
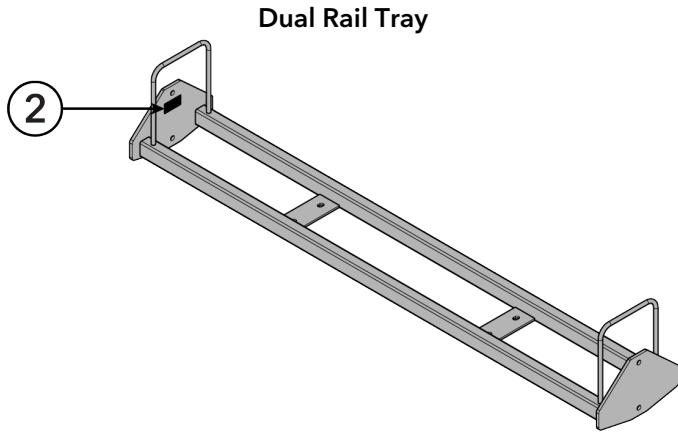
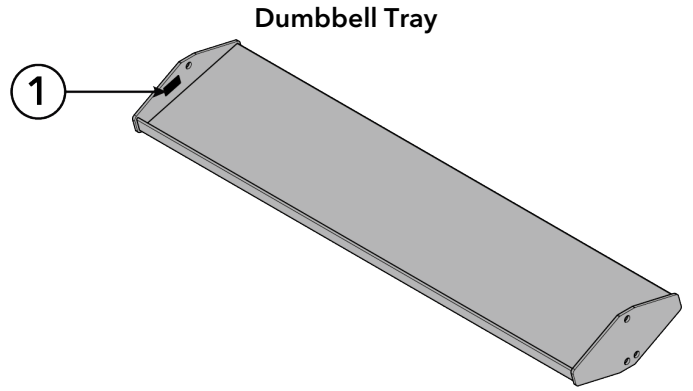
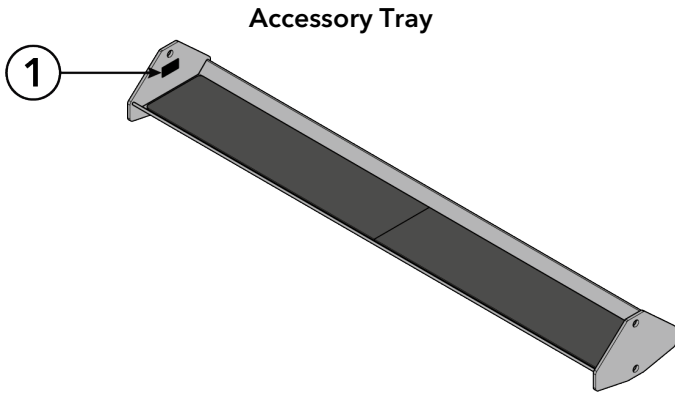

Item	Description	Qty.
1	Max Capacity, 680 LB	2
2	Max Capacity, 1485 LB	1
3	Pinch Hazard	1

Standard HR Bar Catch

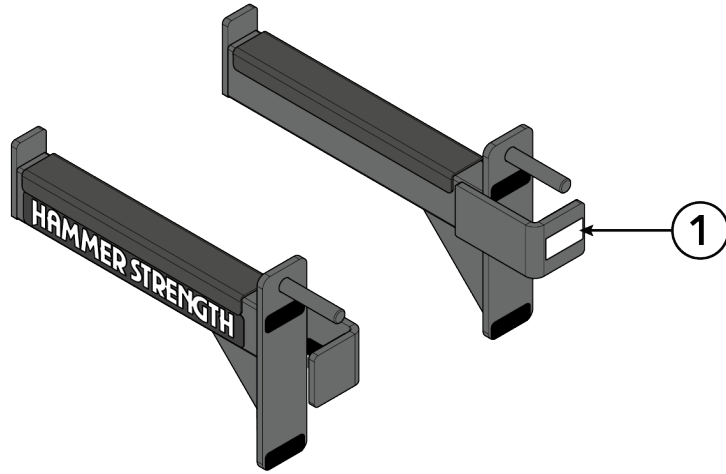

Premium HR Bar Catch

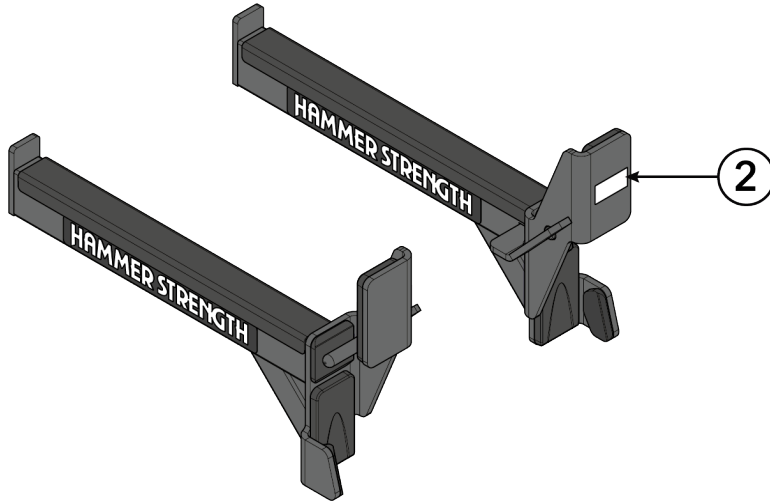

Item	Description	Qty.
1	Max Training, 405 LB	1
2	Max Training, 495 LB	1

Lightning Arms

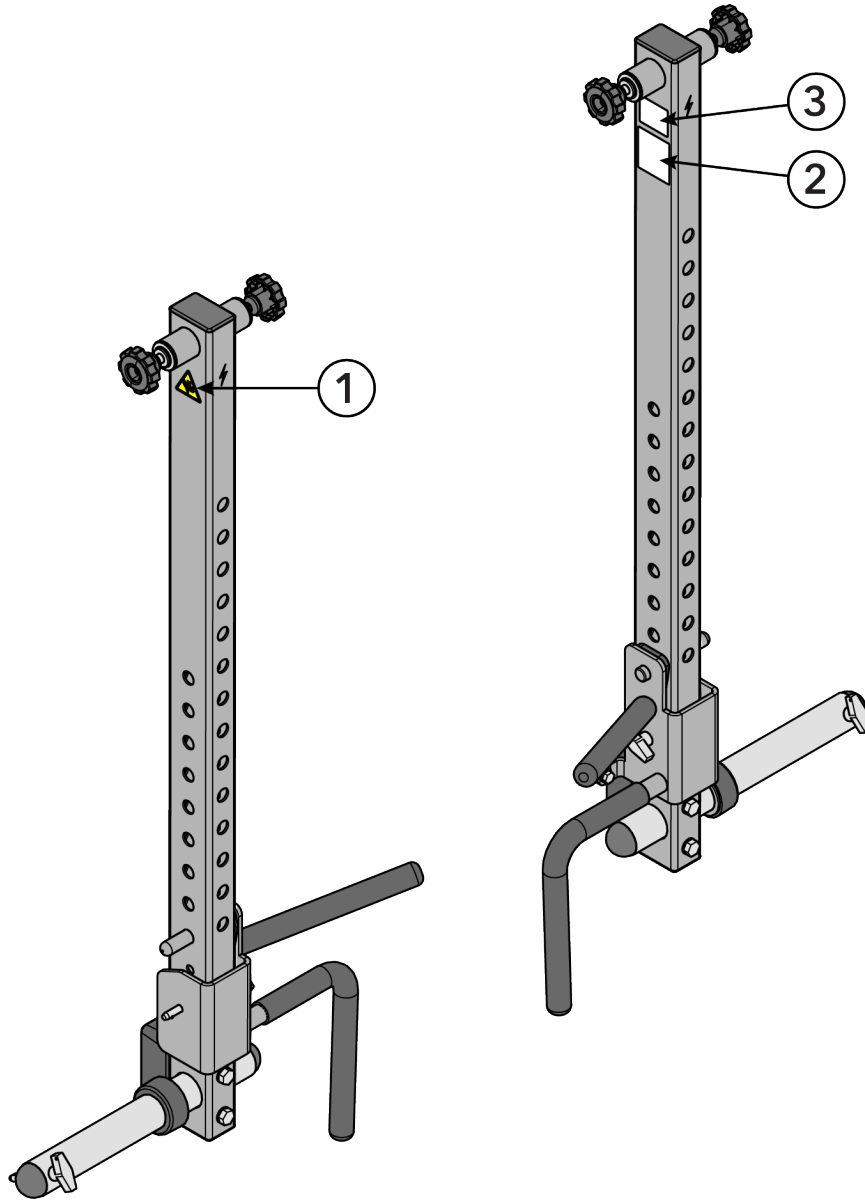

Item	Description	Qty.
1	Pinch Hazard	2
2	Lightning Arm Assembly	2
3	Serial Number	1

Utility Pad

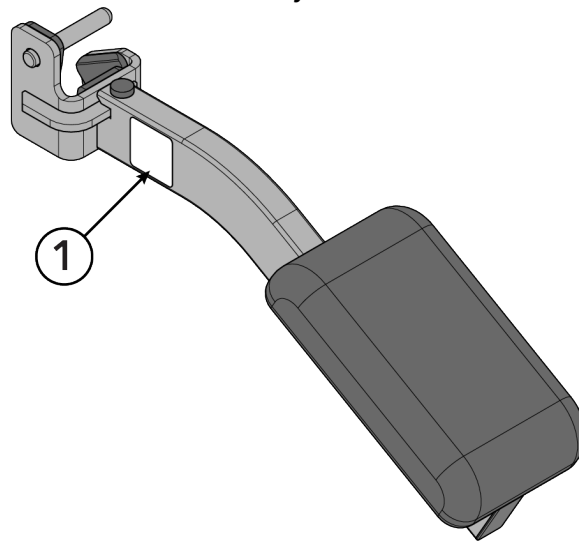

Dip Handle

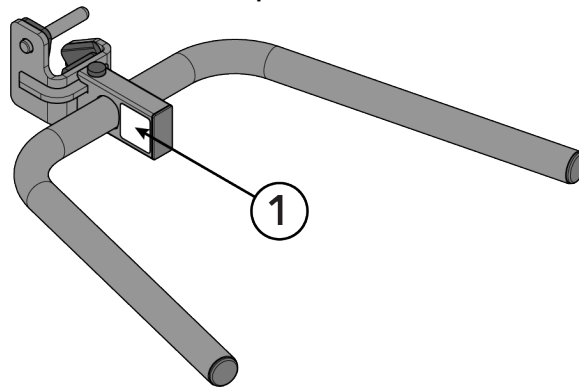

Item	Description	Qty.
1	Stability Rack Attachment	2

2. Assembly

Component and Hardware List

Bar Catches and Supports

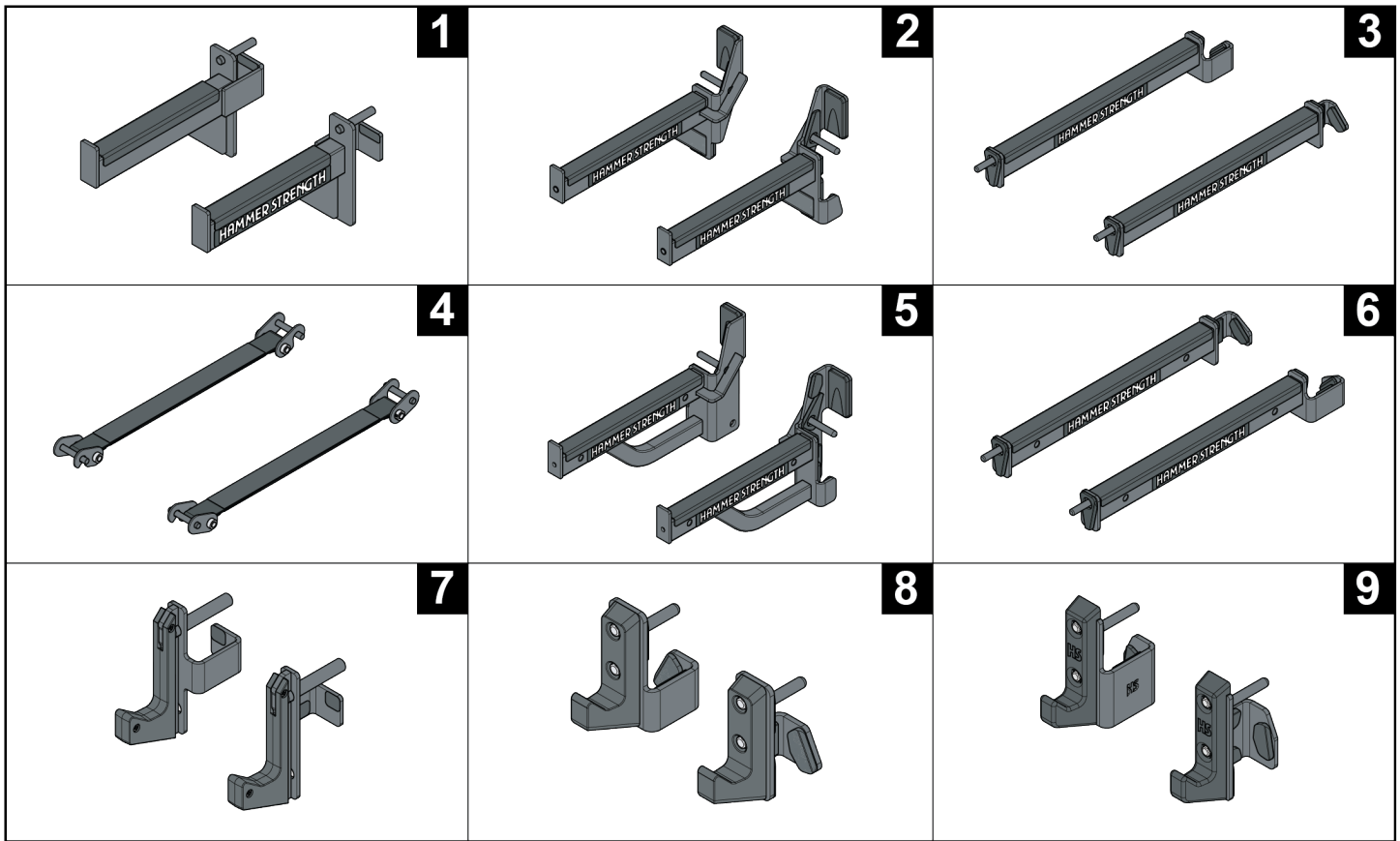

NOTE:

- Bar catches and supports are sold in pairs.
- All bar catches should always be used at or above 28" (71 cm) when performing squat exercises.
- If using HR Bar Catches on the outside of Power Rack training uprights, rack is required to be bolted to floor unless it has stability feet.

Item	Description	NX	iD
1	Standard HR Bar Catch	X	
2	Premium HR Bar Catch	X	
3	Premium PR Bar Catch	X	
4	Flexible PR Bar Catch	X	X
5	HR Bar Catch		X
6	PR Bar Catch		X
7	Standard Bar Support	X	
8	Premium Bar Support	X	
9	4x3 Bar Support		X

Item	Description	NX	iD
13	Spotter Platforms (pair)		X
14	Lightning Arms	X	X
15	Utility Pad	X	X
16	Wall Ball Target	X	X
17	Heavy Bag Hanger	X	X
18	Dip Handle	X	X
19	Ballistic Wing		X
20	Utility Storage (pair)	X	X
21	2-Bar Hanging Storage	X	X
22	Lock Knob	X	X
23	Dual Rail Bumper Plate Divider	X	X
24	Thick Bar Storage	X	X
25	Top Ball Storage	X	X

Weight Horns

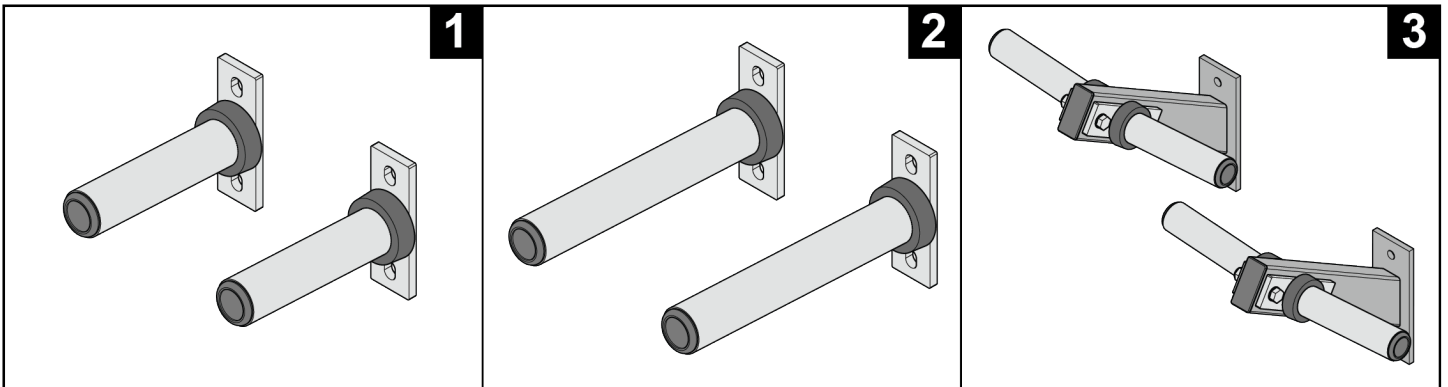

NOTE: Weight horns and bull horns are sold in pairs.

Item	Description	NX	iD
1	7" Weight Horn	X	X
2	11" Weight Horn	X	X
3	Bull Horn		X

42" / 72" Connectors

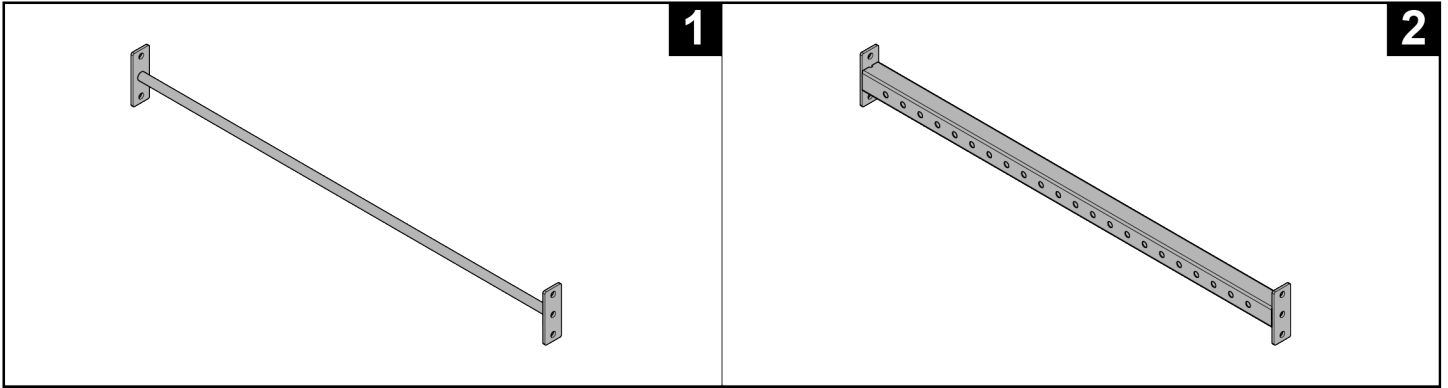

Item	Description	NX	iD
1	Monkey Bar	X	X
2	Square	X	X

42" / 72" Storages

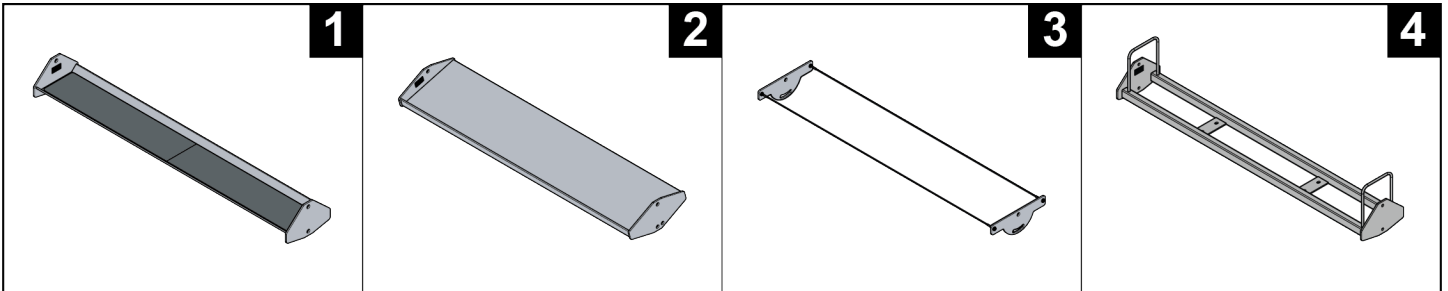

Item	Description	NX	iD
1	Accessory Tray	X	X
2	Dumbbell Tray	X	X
3	Stability Ball	X	X
4	Dual Rail Tray	X	X

Hardware Kit 1

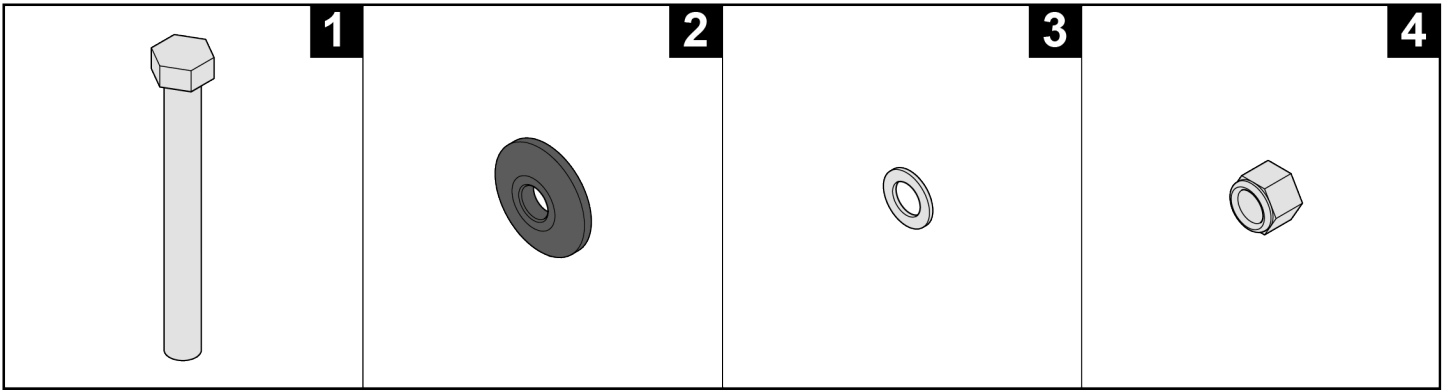

Item	Description	Qty.
1	Bolt, 1/2" x 4 1/2"	4
2	Backing Washer, 1/2"	4
3	Lock Washer, 1/2"	4
4	Lock Nut, 1/2"	4

Hardware Kit 2

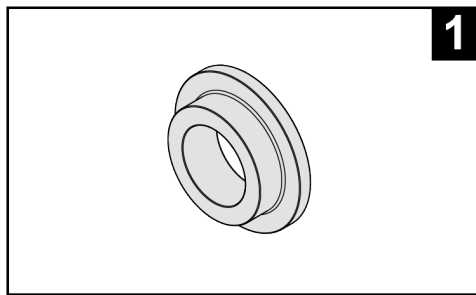

Item	Description	Qty.
1	Step Washer, 1/2"	4

Blister Pack 1

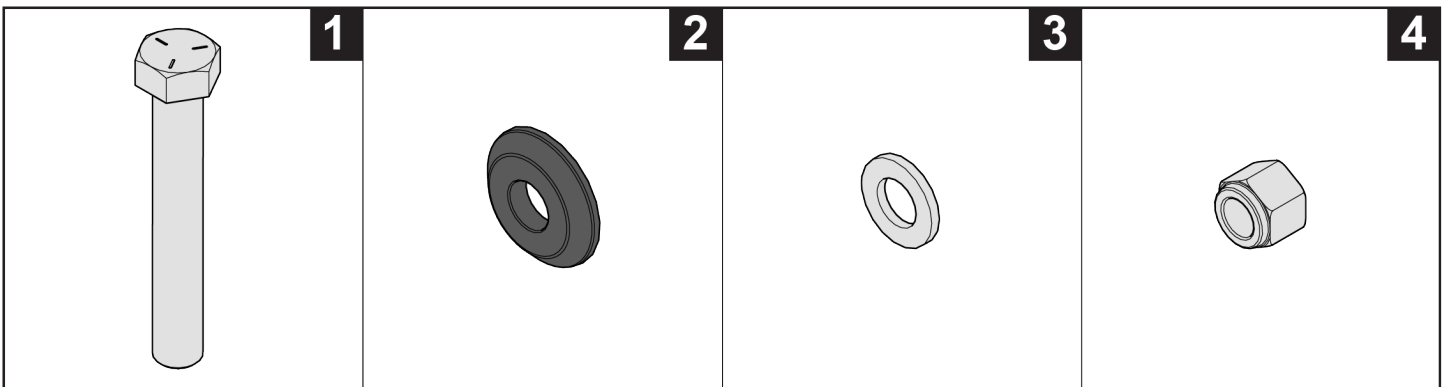

Item	Description	Qty.
1	Bolt, 3/4" x 5"	4
2	Backing Washer, 3/4"	4
3	Lock Washer, 3/4"	8
4	Lock Nut, 3/4"	4

Hardware Kit Configurations

NOTE: Add-Ons not listed below have unique hardware and do not use Hardware Kits or Blister Pack.

Item	Hardware Kit 1	Hardware Kit 2	Blister Pack 1
Weight Horns	X		
Add-Ons			
Hanging Bar Storage	X		
Low Bar Storage	X		
Power Pivot	X	X	
Super Duty Crossmember	X		
3" Ball Grips			X
Arc Bar			X
Neutral Grip Handles			X
42" / 72" Connectors			
Monkey Bar	X	X	
Square	X	X	
42" / 72" Storages			
Accessory Tray	X	X	
Dumbbell Tray	X	X	
Stability Ball	X	X	
Dual Rail Tray	X		

Tools Required

- 3/4" wrench (x2)
- 1-1/16" wrench
- 1-1/8" wrench
- Torque wrench
- 7 mm Allen wrench
- 17 mm wrench

Assembly Procedure

Install Add-Ons

Lock Knob

Lock knobs come with certain add-ons but are also available individually.

1. Lock knobs have magnets inside and can be stuck to rack components.

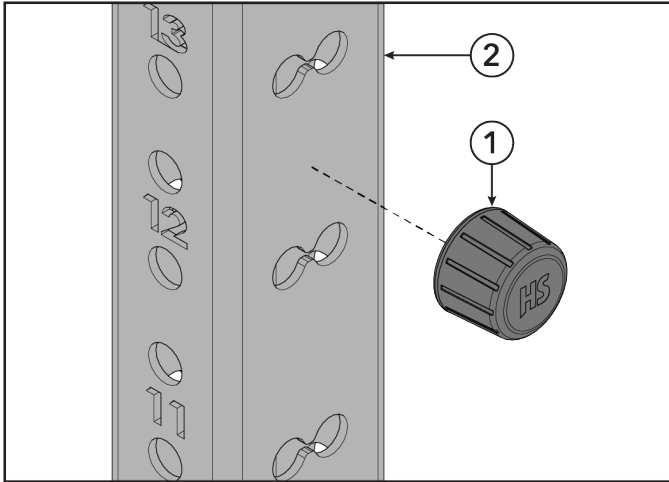

Item	Description	Qty.
1	Lock Knob	1
2	Upright	1

2. Lock knobs have threaded posts inside them that can be screwed into thread holes in certain add-ons.

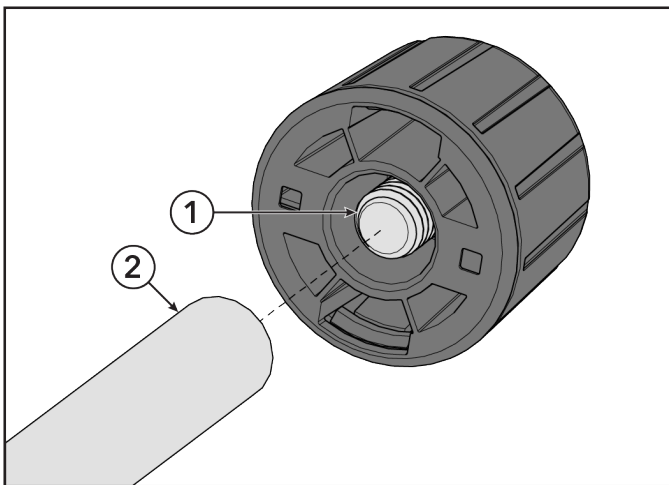

Item	Description	Qty.
1	Threaded Post	1
2	Add-On	1



Hand tighten hardware.

Utility Band Pegs

NOTE: All racks are required to be bolted to floor if training with bands or using suspension training devices.

Install lock knob to threaded shaft to secure utility band peg to frame component.

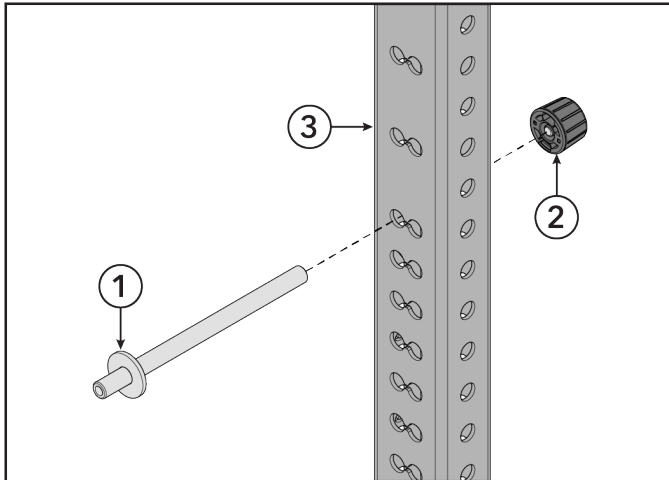

Item	Description	Qty.
1	Band Peg	2
2	Lock Knob	2
3	Upright	2



Hand tighten hardware.

Nordic Ham

Install lock knob to threaded shaft to secure Nordic Ham to upright.

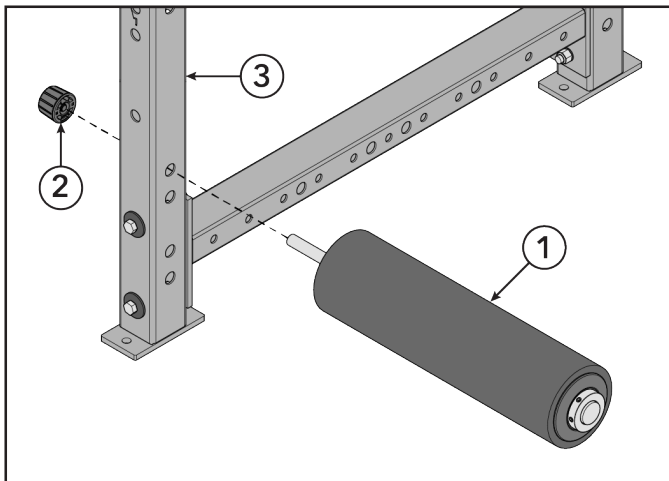

Item	Description	Qty.
1	Nordic Ham	1
2	Lock Knob	1
3	Upright	1



Hand tighten hardware.

Modular Power Pivot

Install lock knob to threaded shaft to secure modular power pivot to training upright.

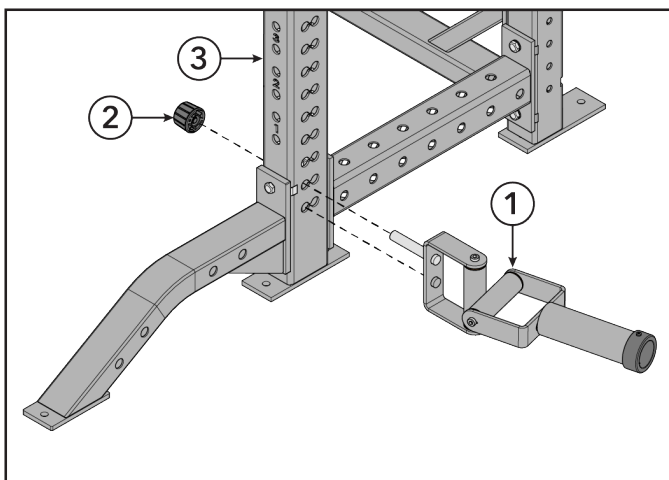

Item	Description	Qty.
1	Modular Power Pivot	1
2	Lock Knob	1
3	Training Upright	1



Hand tighten hardware.

Power Pivot

Install bolts, washers, backing washers, and lock nuts securing power pivot to training upright using two 3/4" wrenches.

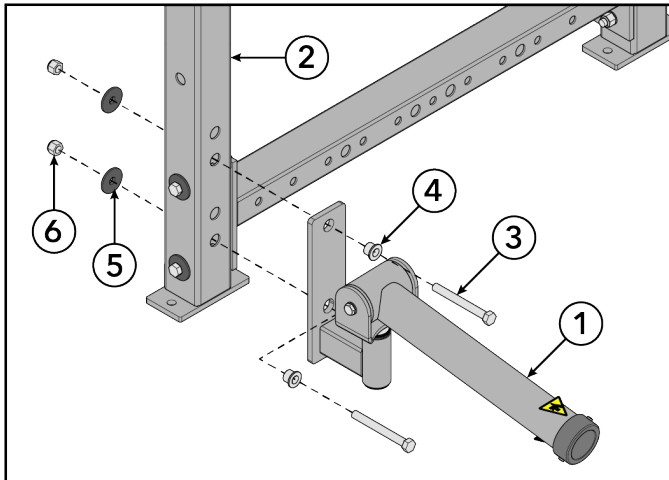

Item	Description	Qty.
1	Power Pivot	1
2	Training Upright	1
3	Bolt, 1/2" x 4 1/2"	2
4	Step Washer, 1/2"	2
5	Backing Washer, 1/2"	2
6	Lock Nut, 1/2"	2



Tighten hardware to 20-25 ft-lb (27-34 Nm).

Hanging Bar Storage

Install bolts, washers, backing washers, and lock nuts securing hanging bar storage to upper crossmember using two 3/4" wrenches.

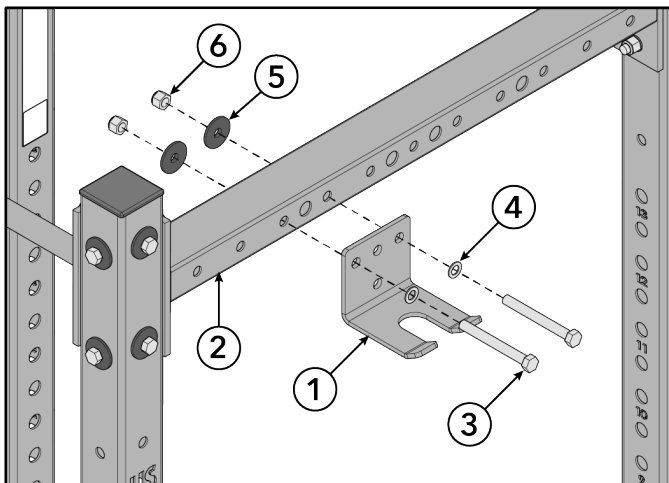

Item	Description	Qty.
1	Hanging Bar Storage	1
2	Upper Crossmember	1
3	Bolt, 1/2" x 4 1/2"	2
4	Lock Washer, 1/2"	2
5	Backing Washer, 1/2"	2
6	Lock Nut, 1/2"	2



Tighten hardware to 20-25 ft-lb (27-34 Nm).

2-Bar Hanging Storage

Install bolts, step washers, backing washers, and jam lock nuts securing 2-bar hanging storage to upper crossmember using two 3/4" wrenches.

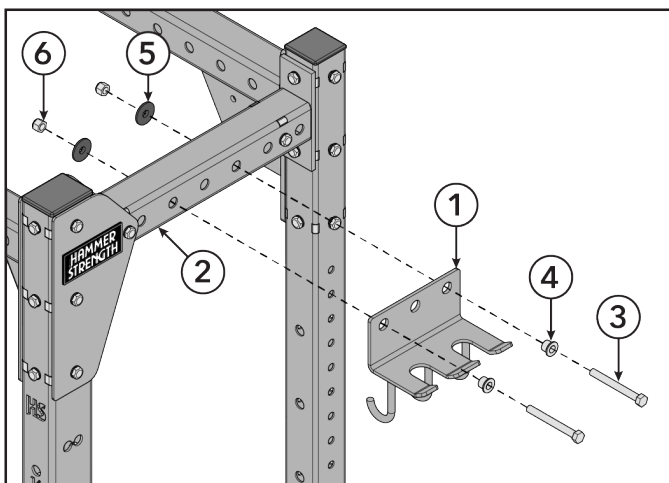

Item	Description	Qty.
1	2-Bar Hanging Storage	1
2	Upper Crossmember	1
3	Bolt, 1/2" x 4"	2
4	Step Washer, 1/2"	2
5	Backing Washer, 1/2"	2
6	Jam Lock Nut, 1/2"	2



Tighten hardware to 20-25 ft-lb (27-34 Nm).

Thick Bar Storage

Install bolts, step washers, backing washers, and lock nuts securing thick bar storage to upper crossmember using two 3/4" wrenches.

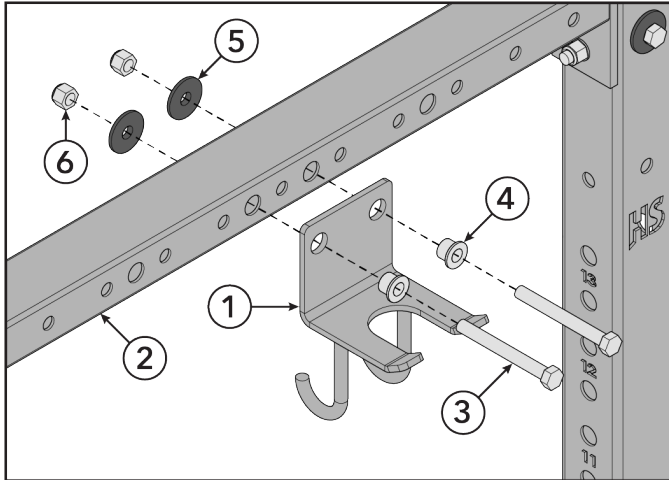

Item	Description	Qty.
1	Thick Bar Storage	1
2	Upper Crossmember	1
3	Bolt, 1/2" x 4 1/2"	2
4	For NX: Step Washer, 1/2" x .20" Deep For iD: Step Washer, 1/2" x .57" Deep	2
5	Backing Washer, 1/2"	2
6	Lock Nut, 1/2"	2



Tighten hardware to 20-25 ft-lb (27-34 Nm).

Top Ball Storage

Install bolts, step washers, backing washers, and lock nuts securing top ball storage to upper crossmember using two 3/4" wrenches.

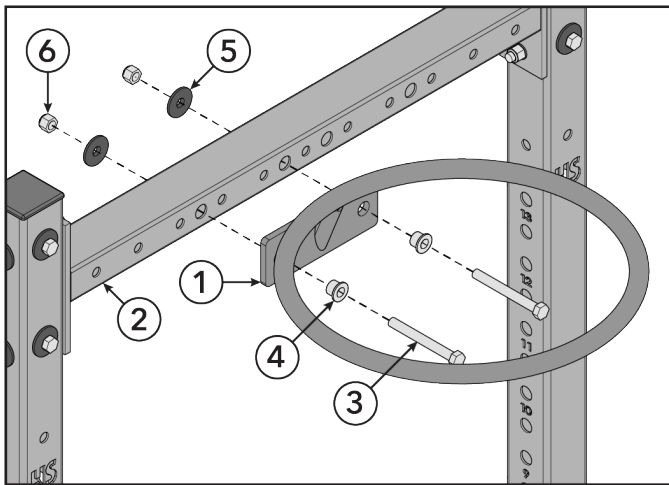

Item	Description	Qty.
1	Top Ball Storage	1
2	Upper Crossmember	1
3	Bolt, 1/2" x 4 1/2"	2
4	For NX: Step Washer, 1/2" x .20" Deep For iD: Step Washer, 1/2" x .57" Deep	2
5	Backing Washer, 1/2"	2
6	Lock Nut, 1/2"	2



Tighten hardware to 20-25 ft-lb (27-34 Nm).

Low Bar Storage

Install bolts, washers, backing washers, and lock nuts securing low bar storage to lower crossmember using two 3/4" wrenches.

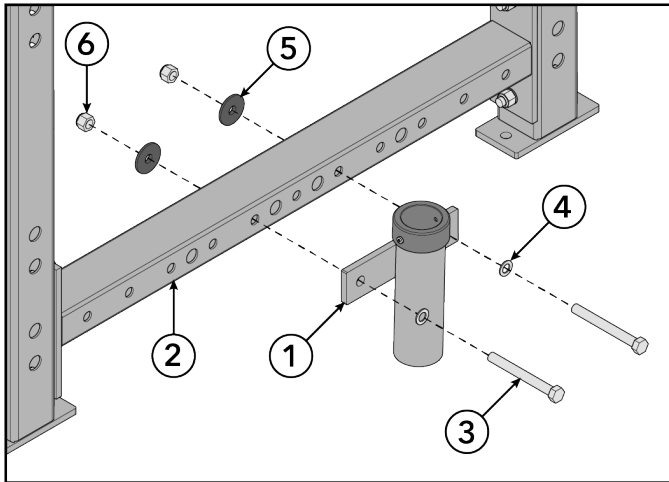

Item	Description	Qty.
1	Low Bar Storage	1
2	Lower Crossmember	1
3	Bolt, 1/2" x 4 1/2"	2
4	Lock Washer, 1/2"	2
5	Backing Washer, 1/2"	2
6	Lock Nut, 1/2"	2



Tighten hardware to 20-25 ft-lb (27-34 Nm).

Super Duty Crossmember

Install bolts, backing washers, washers, and lock nuts securing super duty crossmember to training uprights using two 3/4" wrenches.

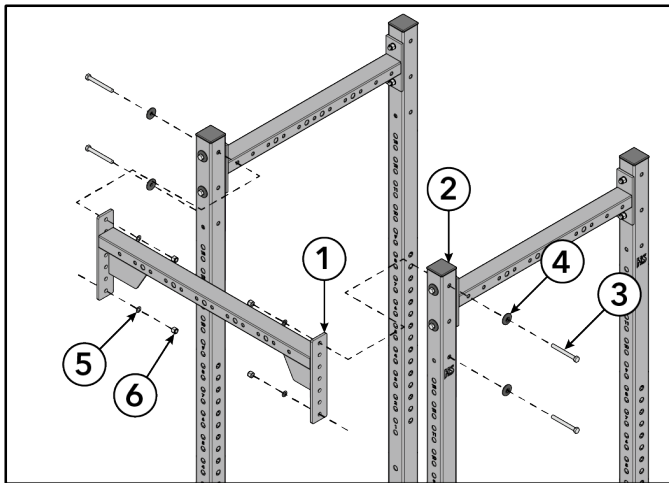

Item	Description	Qty.
1	Super Duty Crossmember	1
2	Training Upright	2
3	Bolt, 1/2" x 4 1/2"	4
4	Backing Washer, 1/2"	4
5	Lock Washer, 1/2"	4
6	Lock Nut, 1/2"	4



Tighten hardware to 20-25 ft-lb (27-34 Nm).

Custom Sign

NOTE: Super duty crossmember is required to install the custom sign.

Install screws, washers, and lock nuts securing optional custom sign and backer plate to super duty crossmember using a 7mm Allen wrench and 17mm wrench.

NOTE: Single custom sign can be installed on the front or rear of super duty crossmember.

Single Custom Sign

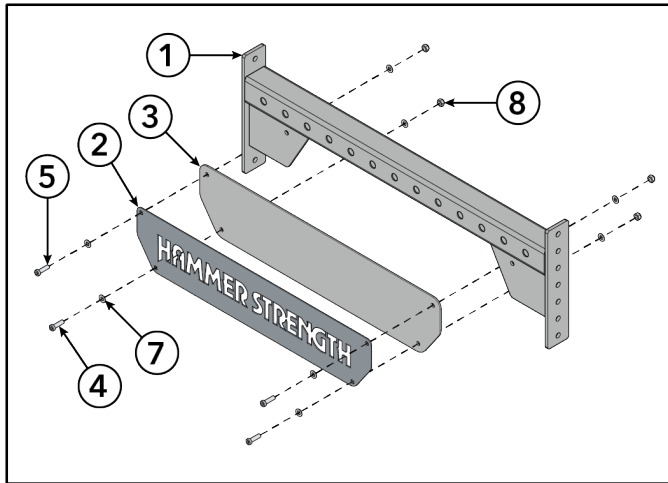

Double Custom Sign

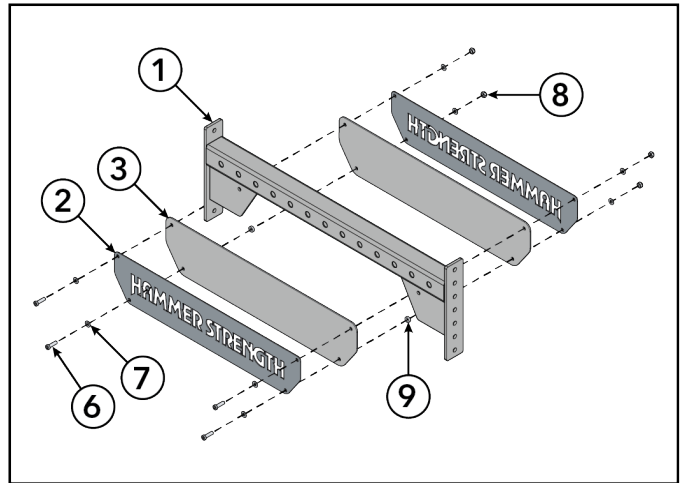

Item	Description	Qty.
1	Super Duty Crossmember	1
2	Custom Sign	1 or 2
3	Backer Plate	1 or 2
4	Screw, M10 x 1.5, 25mm	2
5	Screw, M10 x 1.5, 30mm	2
6	Screw, M10 x 1.5, 35mm	4
7	Flat Washer, 3/8"	8
8	Lock Nut, M10	4
9	Spacer	2



Tighten hardware to 40-50 in-lb (4.5-5.6 Nm).

3" Ball Grips

Install backing washers, washers, and lock nuts securing 3" ball grips to 3x3 crossmember using a 1-1/16" wrench.

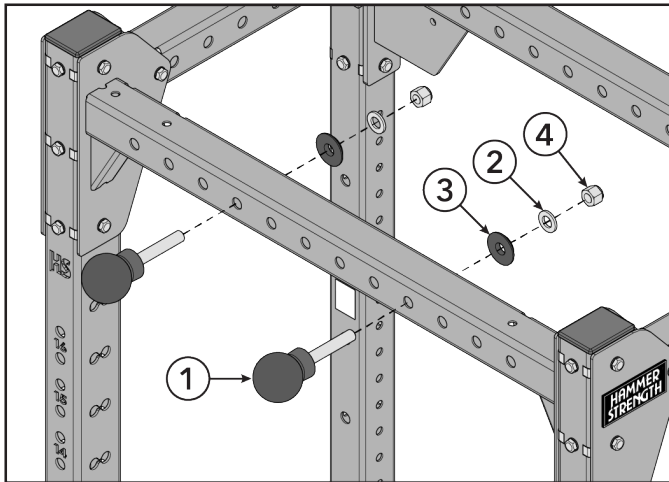

Item	Description	Qty.
1	3" Ball Grip	2
2	Lock Washer, 3/4"	2
3	Backing Washer, 3/4"	2
4	Lock Nut, 3/4"	2



Tighten hardware to 20-25 ft-lb (27-34 Nm).

Arc Bar

Install bolts, washers, backing washers, and lock nuts securing arc bar to 3x3 crossmember using a 1-1/16" and 1-1/8" wrench.

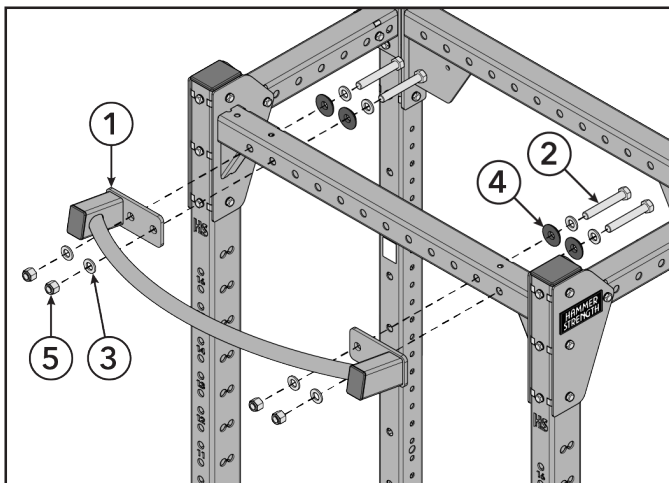

Item	Description	Qty.
1	Arc Bar	1
2	Bolt, 3/4" x 5"	4
3	Lock Washer, 3/4"	8
4	Backing Washer, 3/4"	4
5	Lock Nut, 3/4"	4



Tighten hardware to 20-25 ft-lb (27-34 Nm).

Neutral Grip Handles

Install bolts, washers, backing washers, and lock nuts securing neutral grip handles to 3x3 crossmember using a 1-1/16" and 1-1/8" wrench.

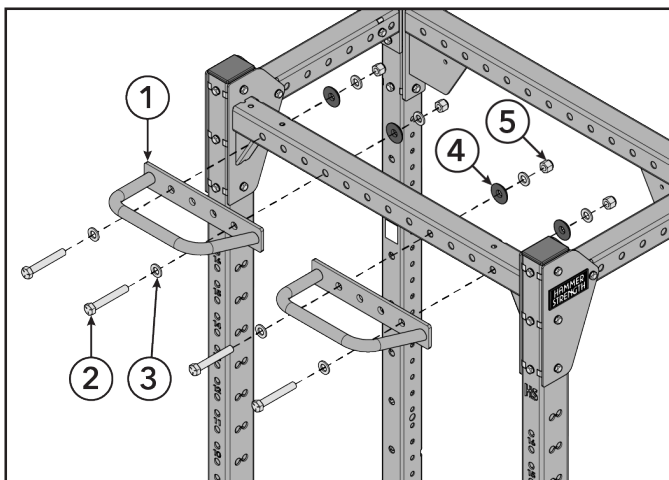

Item	Description	Qty.
1	Neutral Grip Handles	2
2	Bolt, 3/4" x 5"	4
3	Lock Washer, 3/4"	8
4	Backing Washer, 3/4"	4
5	Lock Nut, 3/4"	4



Tighten hardware to 20-25 ft-lb (27-34 Nm).

Dock 'n' Lock

NOTE: Spider gusset crossmember is required to install the Dock 'n' Lock add-on.

Install bolts, washers, backing washers, and lock nuts securing Dock 'n' Lock add-on to spider gusset crossmember using two 3/4" wrenches.

NOTE: Flip Dock 'n' Lock over when installing with a platform.

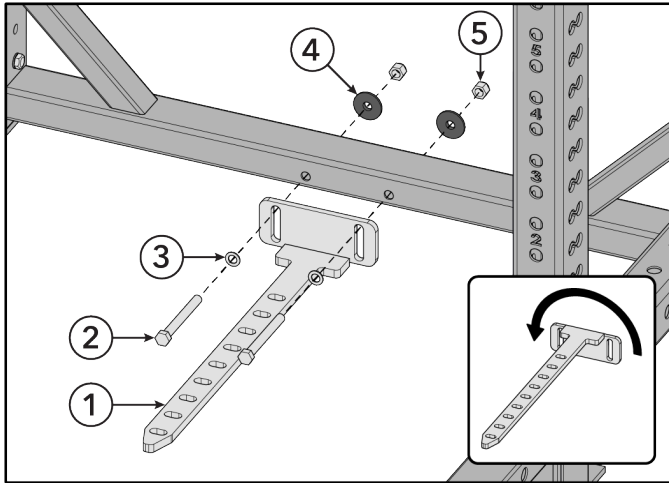

Item	Description	Qty.
1	Dock 'n' Lock	1
2	For HDL: Bolt, 1/2" x 3 1/2" For HDT: Bolt, 1/2" x 4 1/2"	2
3	Lock Washer, 1/2"	2
4	Backing Washer, 1/2"	2
5	Lock Nut, 1/2"	2



Tighten hardware to 20-25 ft-lb (27-34 Nm).

Battle Rope Attachment

Install bolts, backing washers, and step washers securing battle rope attachment to lower crossmember or training upright using a 3/4" wrench.

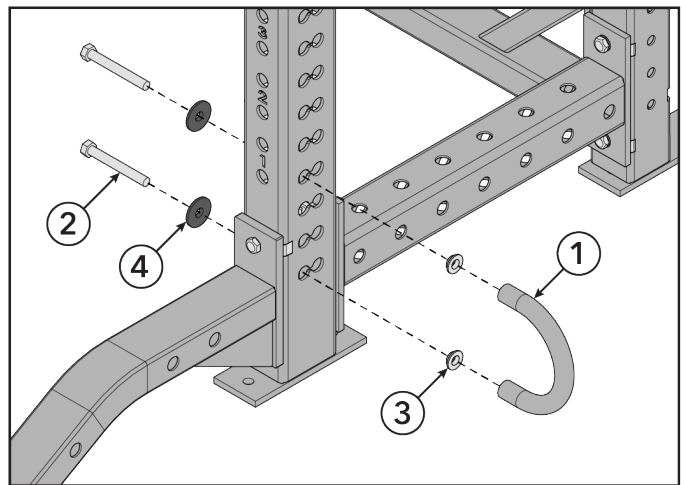
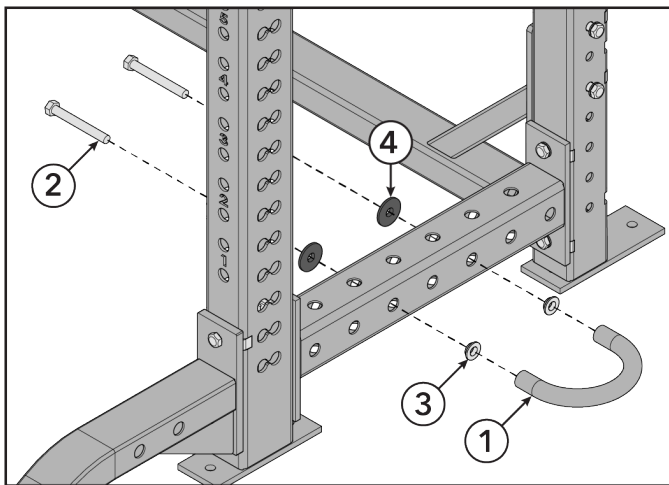

Item	Description	Qty.
1	Battle Rope Attachment	1
2	Bolt, 1/2" x 4"	2
3	Step Washer, 1/2"	2
4	Backing Washer, 1/2"	2



Tighten hardware to 20-25 ft-lb (27-34 Nm).

Lightning Arms

NOTE: Lightning Arms require different hardware when installing to Athletic or Elite Racks.

1. **NOTE:** The following step applies to Elite Racks (iD shown for reference).

Install bolts and washers securing upper bracket to training upright using a 3/4" wrench.

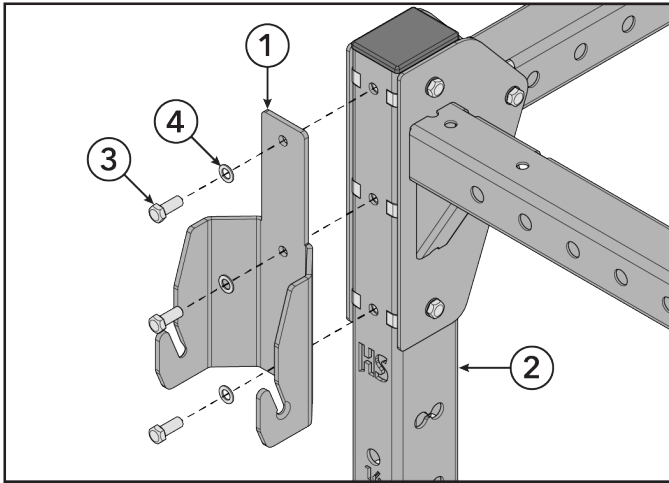

Item	Description	Qty.
1	Upper Bracket	1
2	Training Upright	1
3	Bolt, 1/2"-13 x 1.25"	3
4	Lock Washer, 1/2"	3



Tighten hardware to 45-50 ft-lb (61-67.8 Nm).

2. **NOTE:** The following step applies to Athletic Racks (HDT and NX).

Align R and L upper brackets in the orientation shown below.

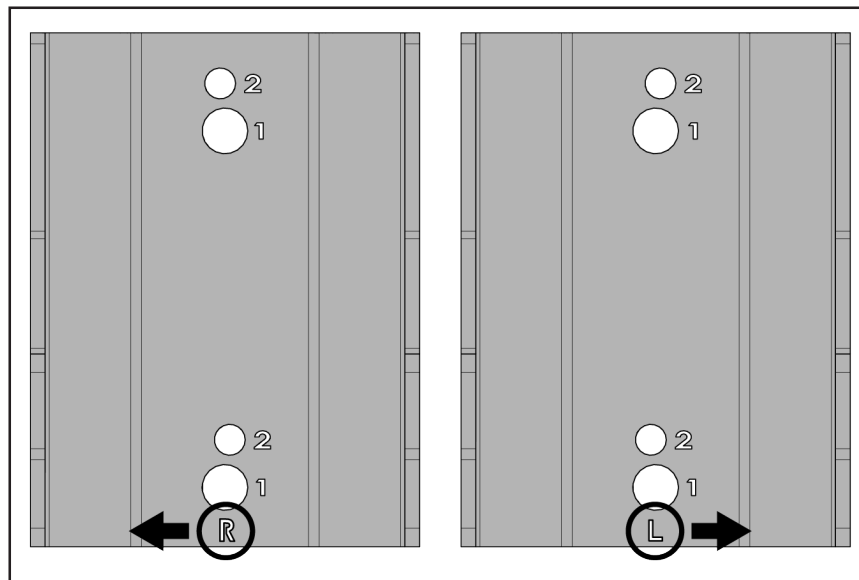

TIP: Bolts go through #1 holes on HDT and #2 on NX.

3. NOTE: The following step applies to HDT Racks.

Install bolts and washers securing upper bracket to training upright using a 1-1/8" wrench.

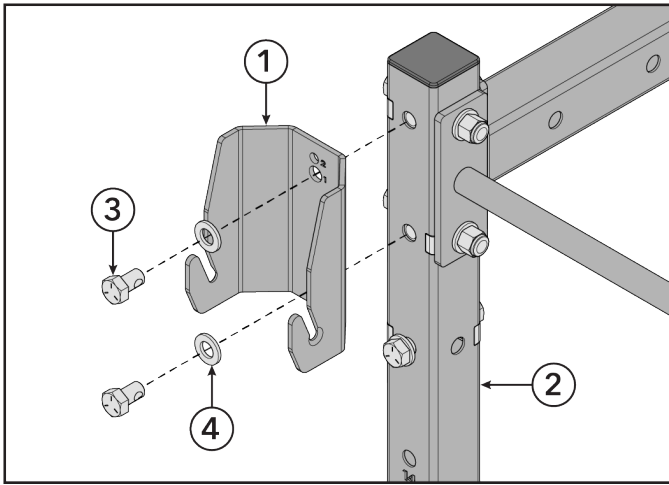

Item	Description	Qty.
1	Upper Bracket	1
2	Training Upright	1
3	Bolt, 3/4" x 1-1/4"	2
4	Lock Washer, 3/4"	2



Tighten hardware to 45-50 ft-lb (61-67.8 Nm).

4. NOTE: The following step applies to NX Racks.

Rotate bracket so #2 holes align with holes in training uprights.

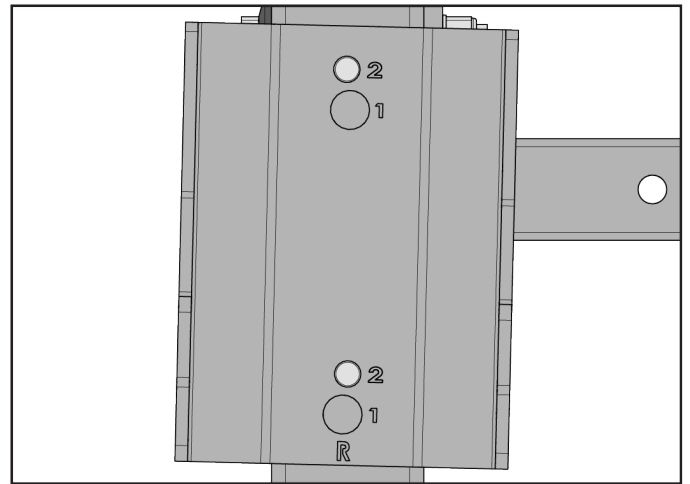
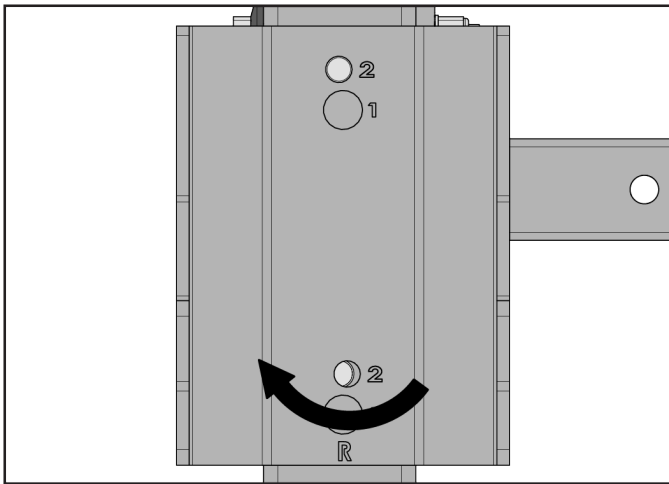

Install bolts, backing washers, washers, and lock nuts securing upper bracket to training upright using two 3/4" wrenches.

NOTE: Backing washers are used on backside of training upright where there is no upper crossmember plate.

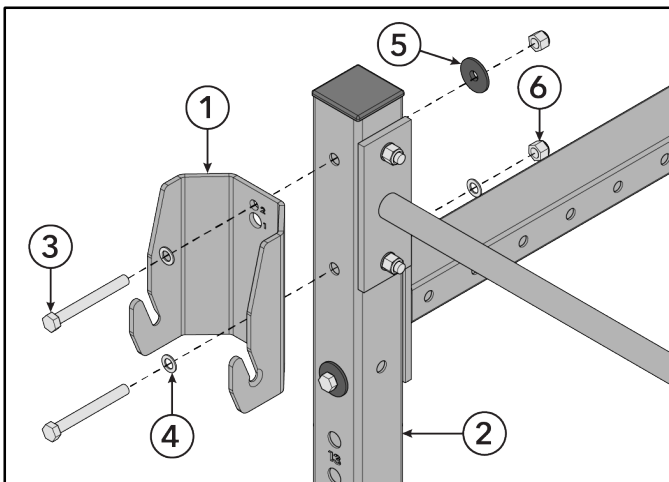

Item	Description	Qty.
1	Upper Bracket	1
2	Training Upright	1
3	Bolt, 1/2" x 4 1/2"	2
4	Lock Washer, 1/2"	2
5	Backing Washer, 1/2"	1
6	Lock Nut, 1/2"	2



Tighten hardware to 20-25 ft-lb (27-34 Nm).

NOTE: Bracket may not be in line with training upright after tightening bolts. After installing the lightning arms, the brackets can be adjusted.

5. NOTE: OPTIONAL

Install bolts, step washers, and lock nuts securing lower brackets to training upright using two 3/4" wrenches.

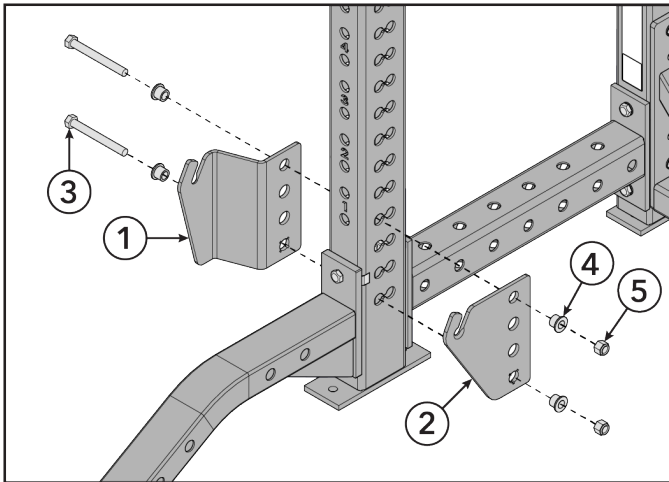

Item	Description	Qty.
1	Lower Bracket, Outside Right	1
2	Lower Bracket, Inside Right	1
3	Bolt, 1/2" x 4 1/2"	2
4	Step Washer, 1/2"	4
5	Lock Nut, 1/2"	2



Tighten hardware to 20-25 ft-lb (27-34 Nm).

NOTE: Countersinks on lower brackets will always be on outside when brackets are installed.

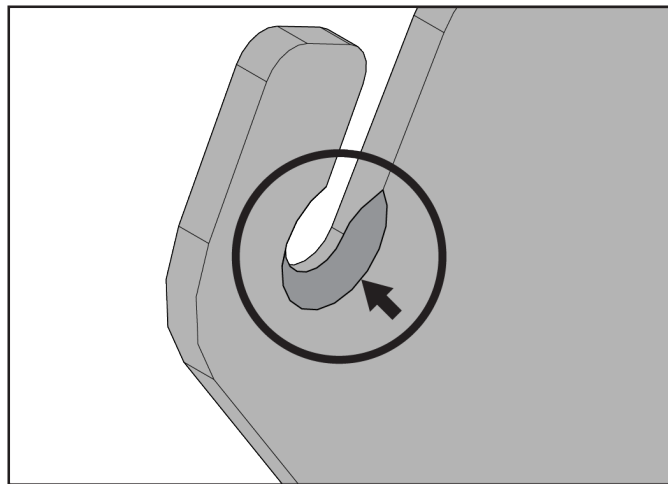

6. Set lightning arm in upper bracket or optional lower bracket channels (upper bracket shown for reference).

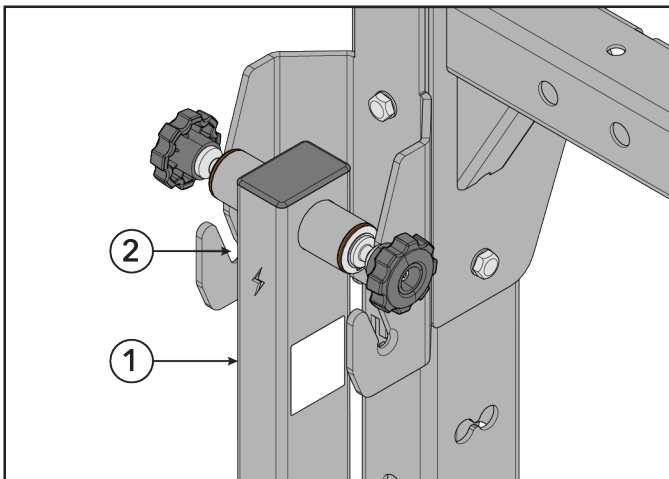

Item	Description	Qty.
1	Lightning Arm	1
2	Upper Bracket Channel	2

7. Turn knobs on lightning arms clockwise to secure in place.

NOTE: Tighten fully so that knobs pinch bracket onto lightning arm pivot shaft.

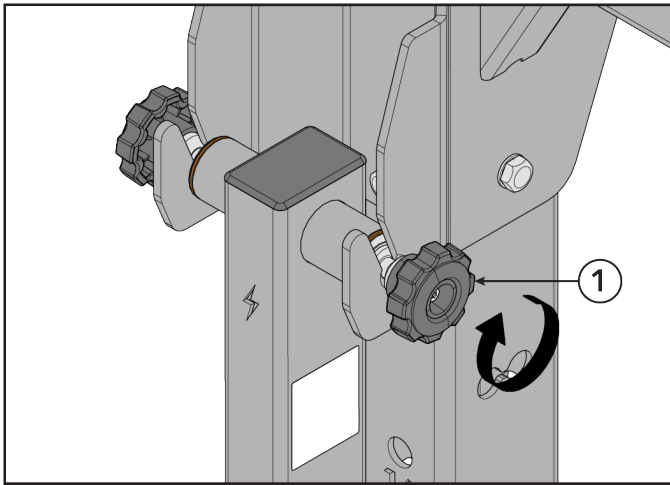

Item	Description	Qty.
1	Knob	2

8. **NOTE:** The following step applies to NX Racks.

Press lightning arm in towards center of rack to twist the upper bracket until it is straight with the training uprights.

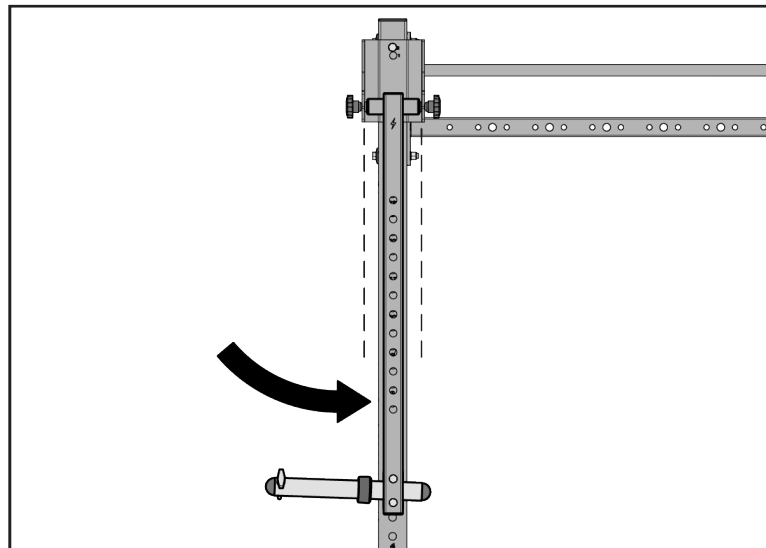

9. Tip handle assembly up and slide into lightning arm.

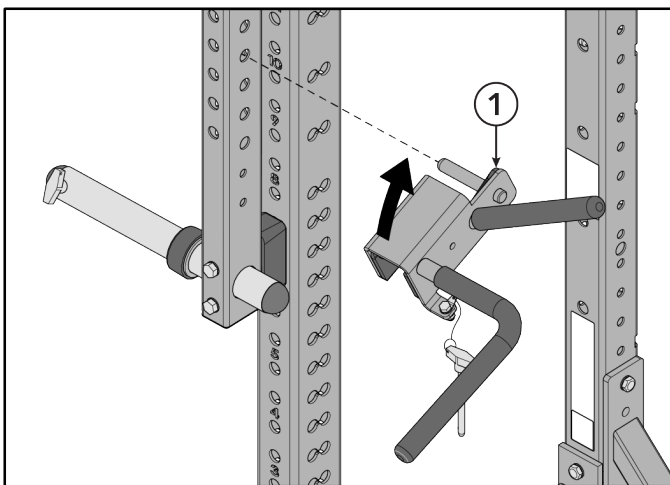

Item	Description	Qty.
1	Handle Assembly	1

10. Install pin securing handle assembly to lightning arm.

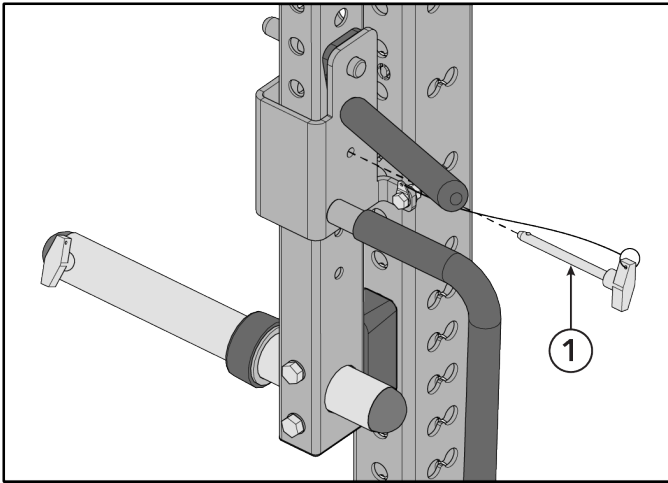

Item	Description	Qty.
1	Pin	1

11. Repeat Steps 1-10 to install opposite lightning arm.

12. Install bolts, step washers, backing washers, and lock nuts securing lightning arms storage bracket to inside of storage upright using two 3/4" wrenches.

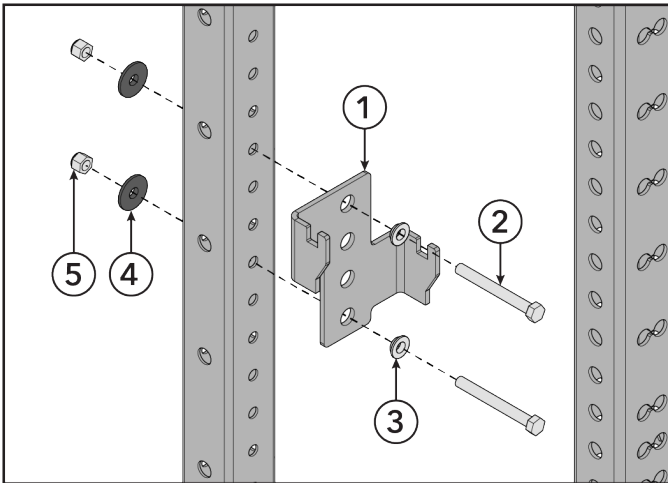

Item	Description	Qty.
1	Lightning Arms Storage Bracket	1
2	Bolt, 1/2" x 4 1/2"	2
3	Step Washer, 1/2"	2
4	Backing Washer, 1/2"	2
5	Lock Nut, 1/2"	2



Tighten hardware to 20-25 ft-lb (27-34 Nm).

NOTE: Storage bracket is used to hang lightning arms from storage uprights.

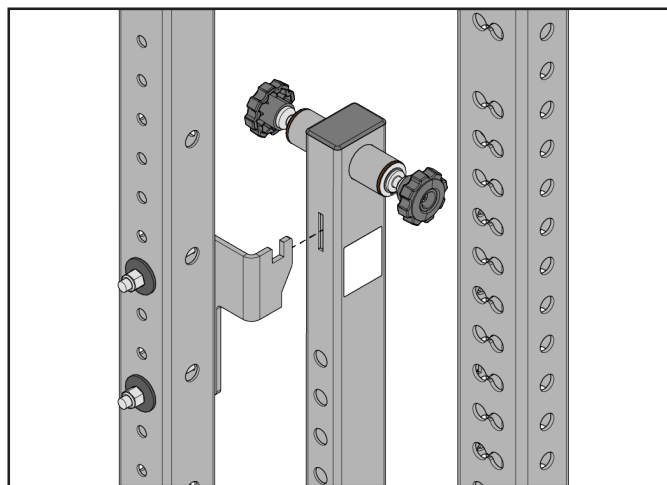

Spotter Platforms

1. Align spotter platforms on the inside of rack.
2. Tip spotter platform up and slide into training upright.

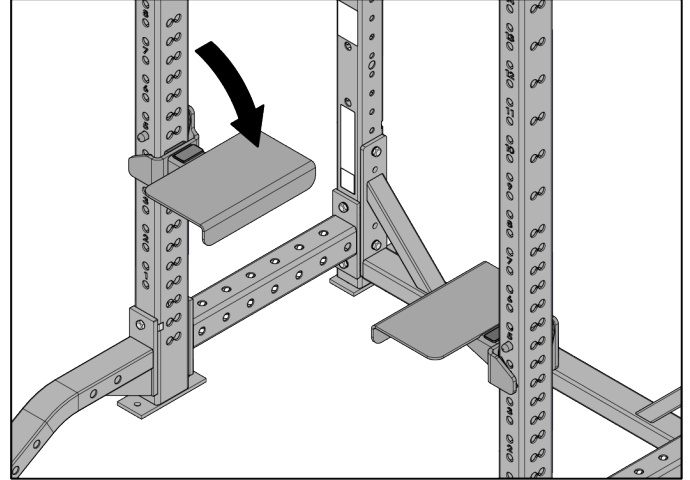
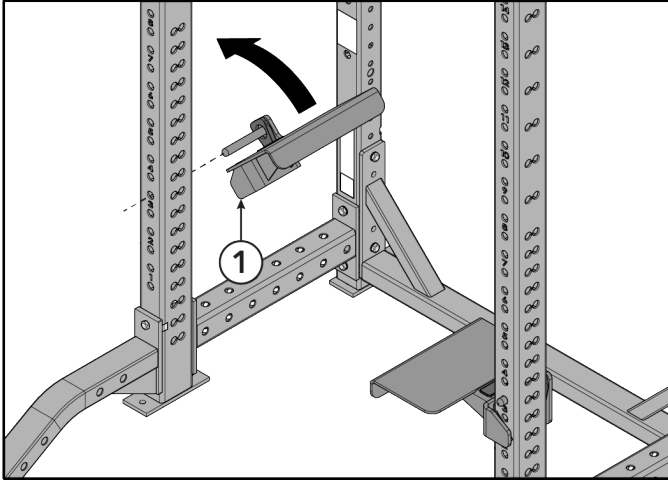

Item	Description	Qty.
1	Spotter Platform	2

3. Tip spotter platform down and into place.

Utility Storage

1. Align utility storage on the inside of rack.
2. Tip utility storage up and slide into upright.

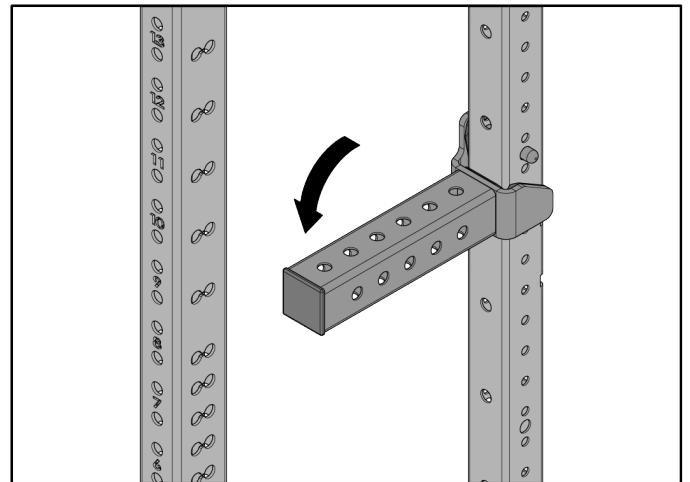
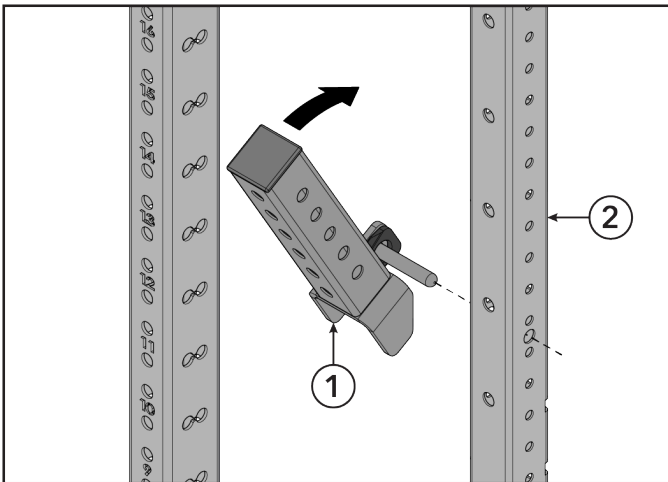

Item	Description	Qty.
1	Utility Storage	2
2	Upright	2

3. Tip utility storage down and into place.

Dip Handle

1. Tip dip handle up and slide into training upright.

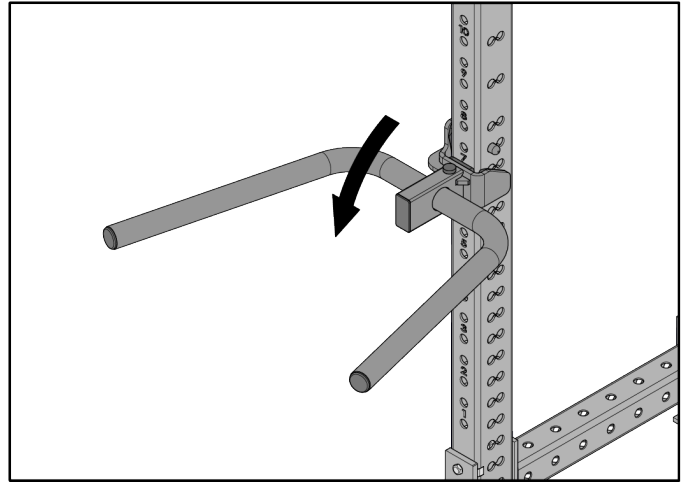
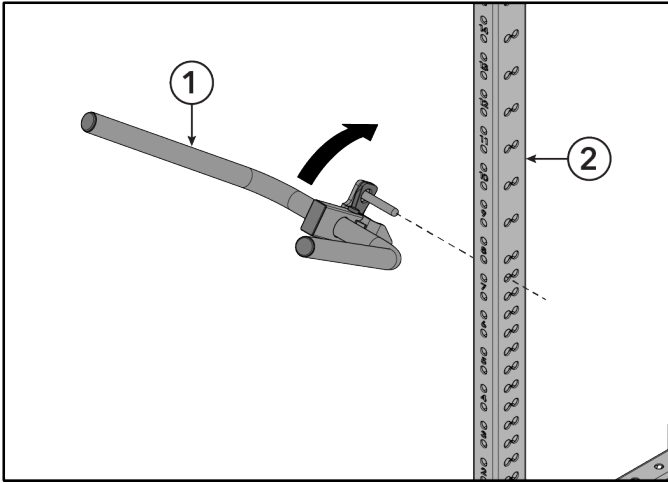

Item	Description	Qty.
1	Dip Handle	1
2	Training Upright	1

2. Tip dip handle down and into place.

Utility Pad

1. Tip utility pad up and slide into training upright.

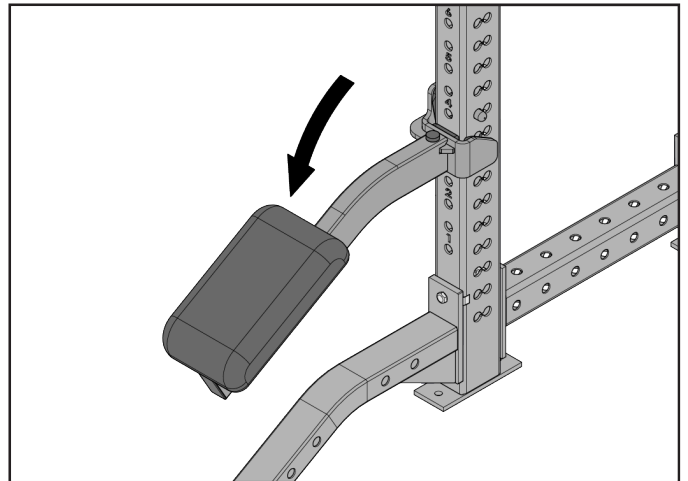
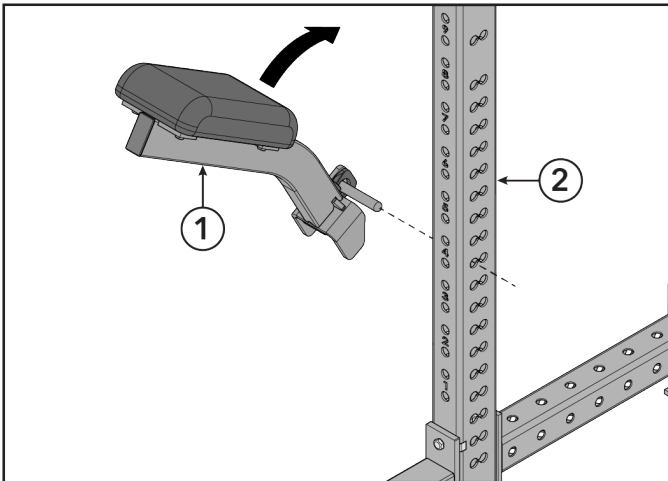

Item	Description	Qty.
1	Utility Pad	1
2	Training Upright	1

2. Tip utility pad down and into place.

Wall Ball Target

NOTE: Wall Ball Target requires different hardware when installing to Athletic or Elite Racks.

1. **NOTE:** The following step applies to Elite Racks (iD shown for reference).

Install bolts and step washers securing wall ball target to training upright using a 3/4" wrench.

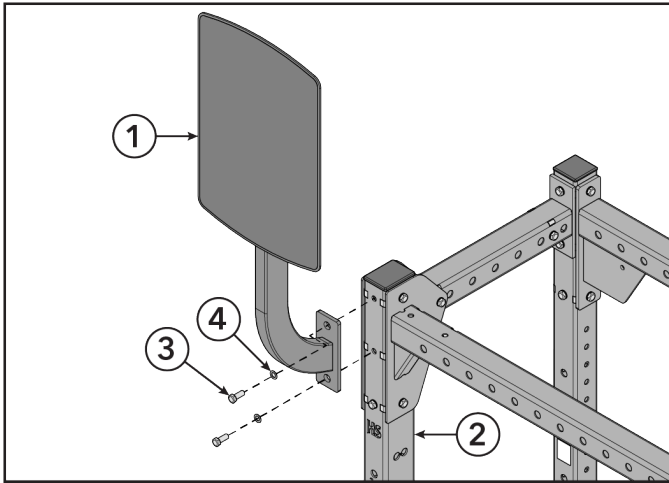

Item	Description	Qty.
1	Wall Ball Target	1
2	Training Upright	1
3	Bolt, 1/2"-13 x 1.25"	2
4	Step Washer, 1/2"	2



Tighten hardware to 45-50 ft-lb (61-67.8 Nm).

2. **NOTE:** The following step applies to NX Racks.

Install bolts, step washers, washers, backing washers, and lock nuts securing wall ball target to training upright using two 3/4" wrenches.

NOTE: Backing washers are used on backside of training upright where there is no upper crossmember plate.

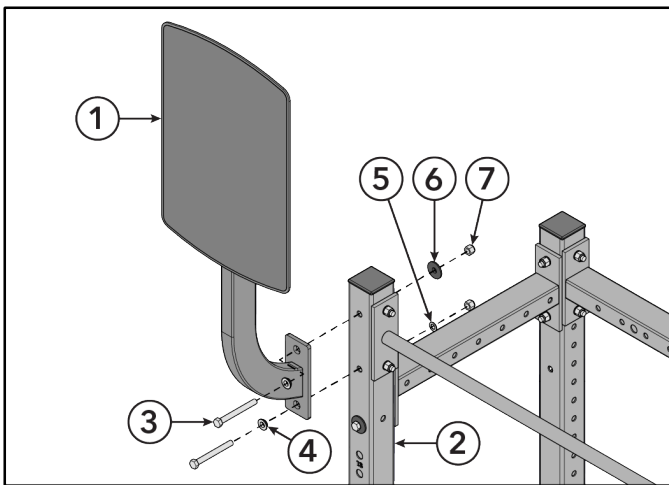

Item	Description	Qty.
1	Wall Ball Target	1
2	Training Upright	1
3	Bolt, 1/2" x 4 1/2"	2
4	Step Washer, 1/2"	2
5	Lock Washer, 1/2"	1
6	Backing Washer, 1/2"	1
7	Lock Nut, 1/2"	2



Tighten hardware to 20-25 ft-lb (27-34 Nm).

3. NOTE: The following step applies to HDT Racks

Install bolts and washers securing wall ball target to training upright using a 1-1/8" wrench.

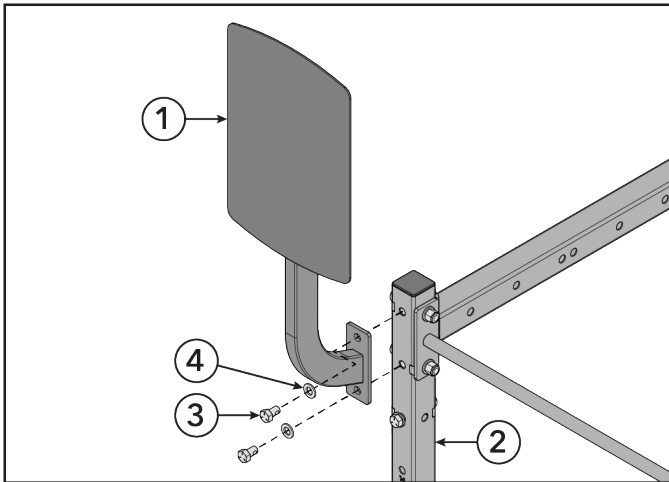

Item	Description	Qty.
1	Wall Ball Target	1
2	Training Upright	1
3	Bolt, 3/4" x 1-1/4"	2
4	Lock Washer, 3/4"	2



Tighten hardware to 45-50 ft-lb (61-67.8 Nm).

Heavy Bag Hanger

NOTE: Heavy Bag Hanger requires different hardware when installing to Athletic or Elite Racks.

1. NOTE: The following step applies to Elite Racks (iD shown for reference).

Install bolts and step washers securing heavy bag hanger to training upright using a 3/4" wrench.

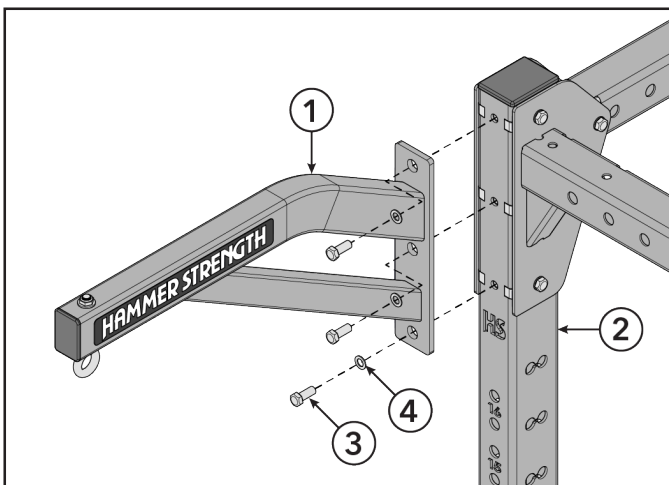

Item	Description	Qty.
1	Heavy Bag Hanger	1
2	Training Upright	1
3	Bolt, 1/2"-13 x 1.25"	3
4	Step Washer, 1/2"	3



Tighten hardware to 45-50 ft-lb (61-67.8 Nm).

2. **NOTE:** The following step applies to NX Racks.

Install bolts, step washers, washers, backing washers, and lock nuts securing heavy bag hanger to training upright using two 3/4" wrenches.

NOTE: Backing washers are used on backside of training upright where there is no upper crossmember plate.

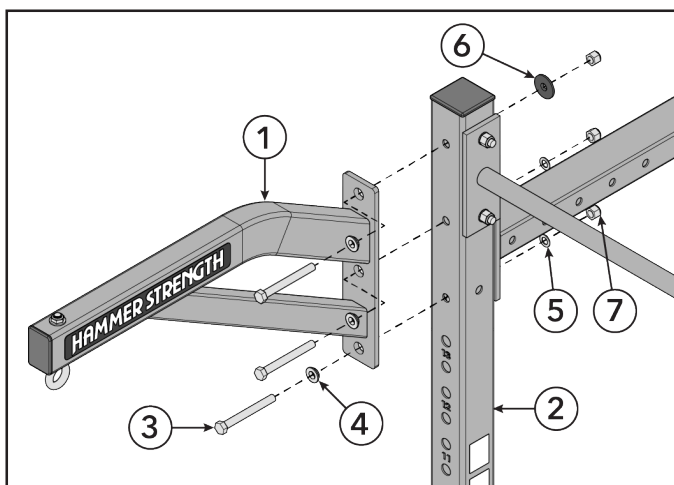

Item	Description	Qty.
1	Heavy Bag Hanger	1
2	Training Upright	1
3	Bolt, 1/2" x 4 1/2"	3
4	Step Washer, 1/2"	3
5	Lock Washer, 1/2"	2
6	Backing Washer, 1/2"	1
7	Lock Nut, 1/2"	3



Tighten hardware to 20-25 ft-lb (27-34 Nm).

3. **NOTE:** The following step applies to HDT Racks

Install bolts and washers securing heavy bag hanger to training upright using a 1-1/8" wrench.

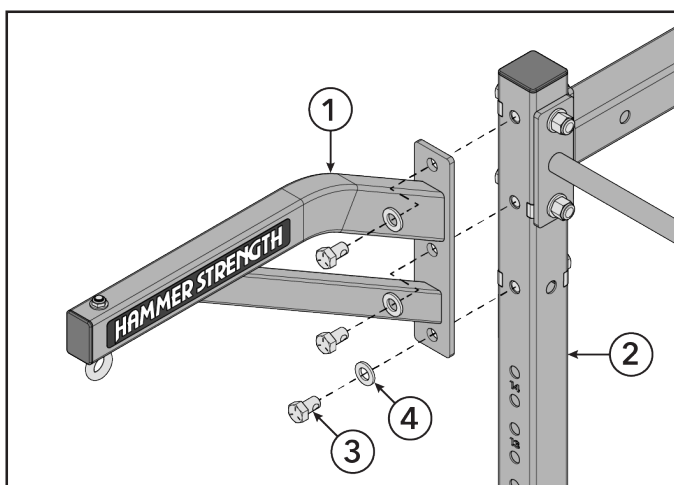

Item	Description	Qty.
1	Heavy Bag Hanger	1
2	Training Upright	1
3	Bolt, 3/4" x 1-1/4"	3
4	Lock Washer, 3/4"	3



Tighten hardware to 45-50 ft-lb (61-67.8 Nm).

Ballistic Wing

1. Install bolts, washers, step washers, lock nuts, and rectangle tubing nuts securing ballistic wing to 3x3 crossmember and upper side crossmembers using two 3/4" wrenches.

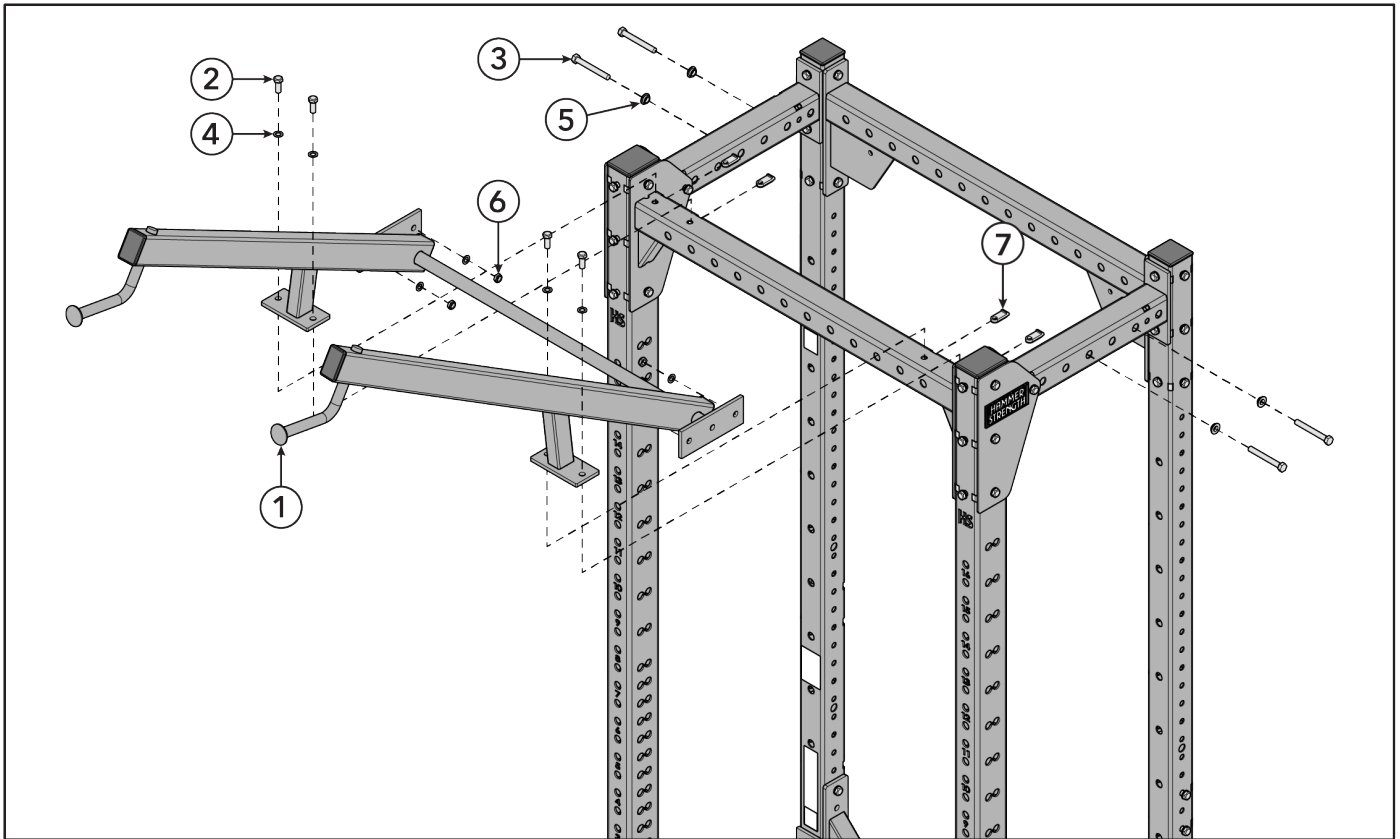

Item	Description	Qty.
1	Ballistic Wing	1
2	Bolt, 1/2"-13 x 1.25"	4
3	Bolt, 1/2" x 4"	4
4	Lock Washer, 1/2"	8
5	Step Washer, 1/2"	4
6	Lock Nut, 1/2" Thin	4
7	Rectangle Tubing Nut, 11GA, 3"	4

2. Tighten 4" bolts to 20-25 ft-lb (27-34 Nm).
3. Tighten 1.25" bolts to 45-50 ft-lb (61-67.8 Nm).

Flexible Bar Catches

NOTE: Flexible bar catches can be installed to Power Racks, Power / Half Combo Racks, and Power / Power Combo Racks.

Install flexible bar catches to training uprights by lifting the latch and sliding the pivot shaft into training upright hole.

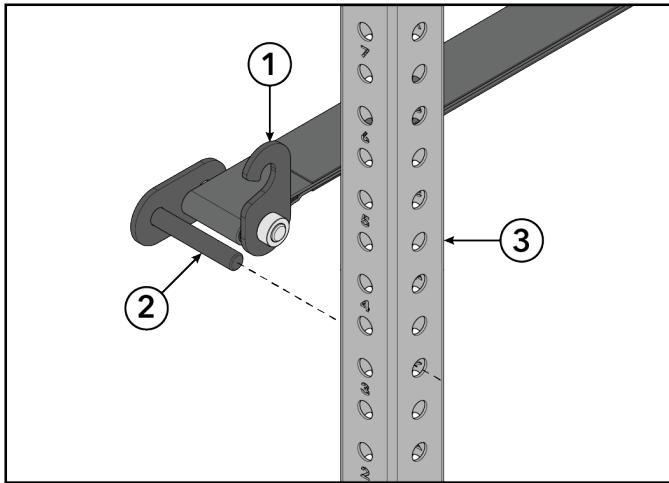

Item	Description	Qty.
1	Latch	4
2	Pivot Shaft	4
3	Training Upright	4

NOTE: Latches are designed to go over the top of pivot shafts.

Correct Latch Direction

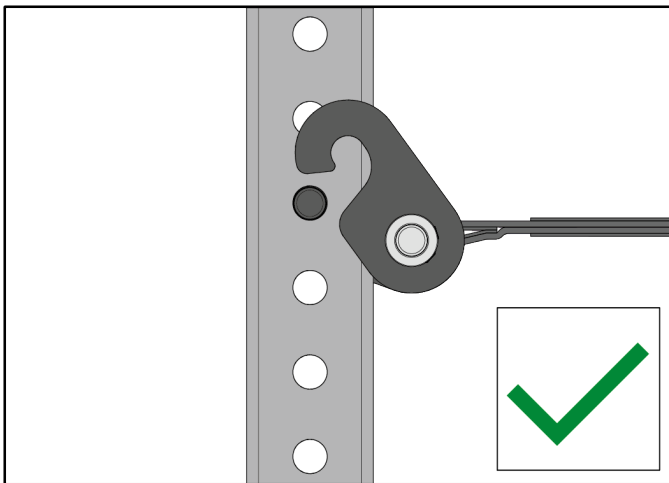

Incorrect Latch Direction

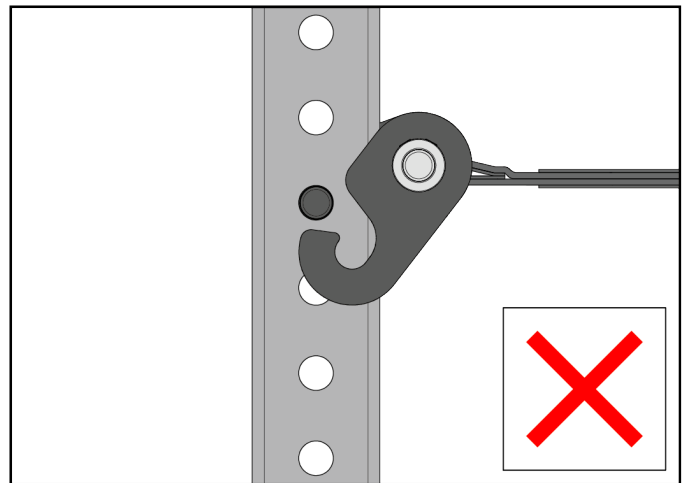

NOTE: Do NOT offset flexible bar catches more than three hole positions.

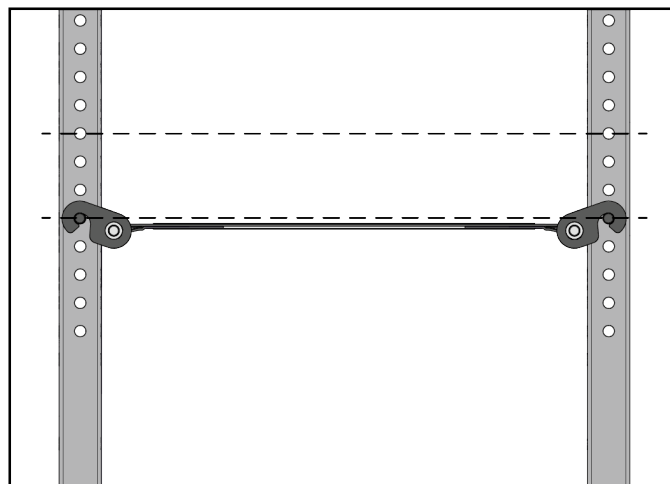

Weight Horns

Install bolts, washers, backing washers, and lock nuts securing weight horns to storage uprights using two 3/4" wrenches.

IMPORTANT: Confirm weight horns are angled upwards when installing.

NOTE: The bottom two weight horns are installed using rectangle tubing nuts on iD Racks.

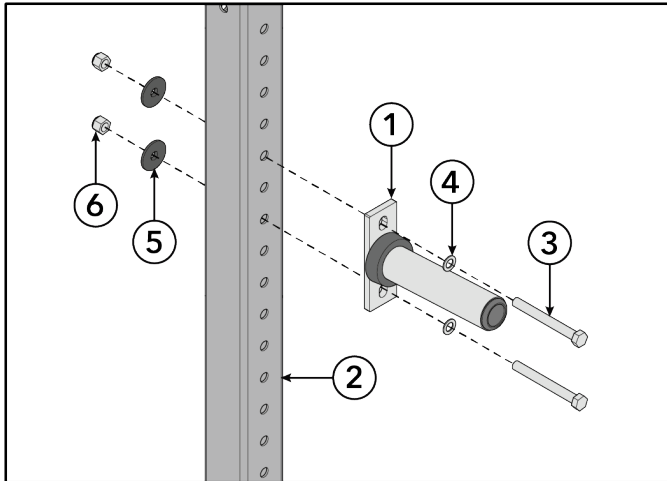

Item	Description	Qty.
1	Weight Horn	8
2	Storage Upright	2
3	Bolt, HHB .5 x 4.5	16
4	Lock Washer, 1/2"	16
5	Backing Washer, 1/2"	16
6	Lock Nut, 1/2"	16



Tighten hardware to 20-25 ft-lb (27-34 Nm).

Weight Horn Configurations

NOTE: Weight horns can be installed in different configurations depending on type of weight plates being used.

4 Weight Horn

Bumper Plate Configuration

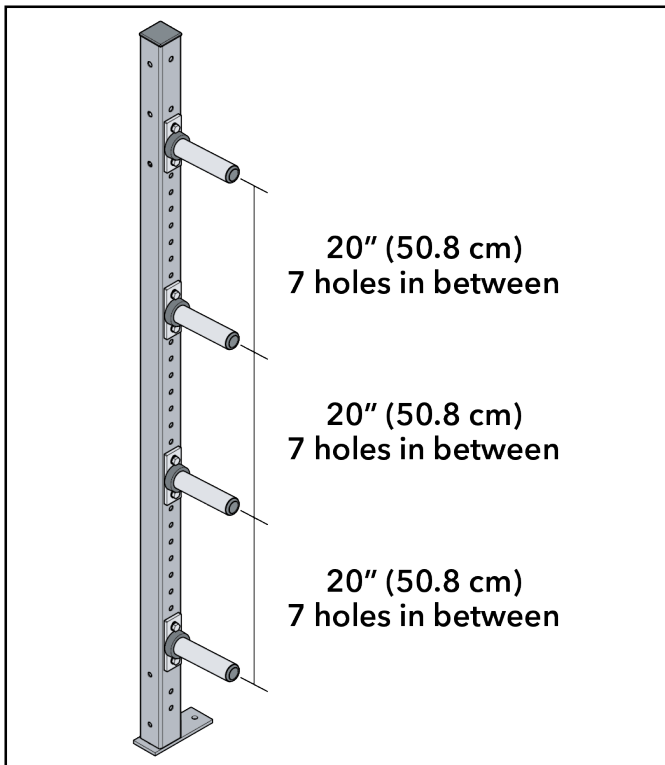

4 Weight Horn

Olympic Plate Configuration

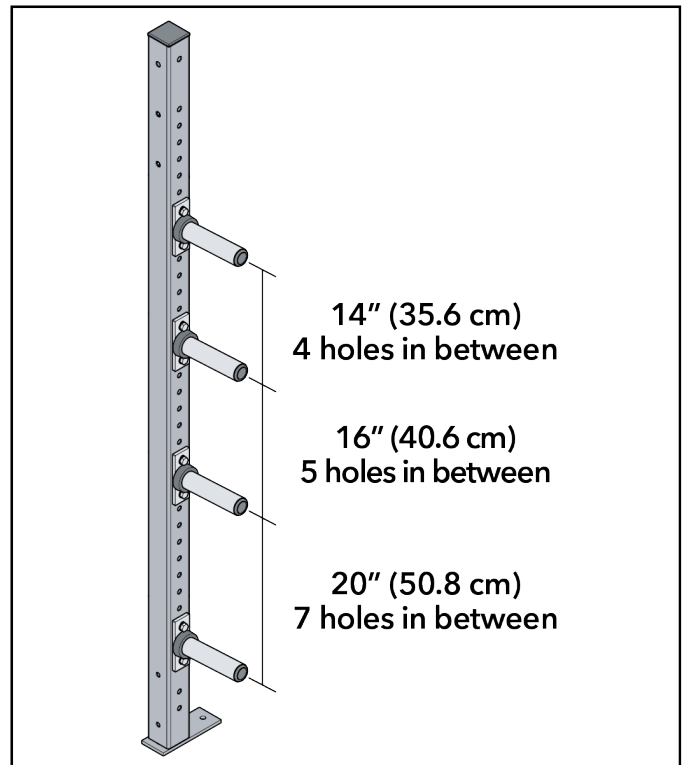

**5 Weight Horn
Olympic Plate Configuration**

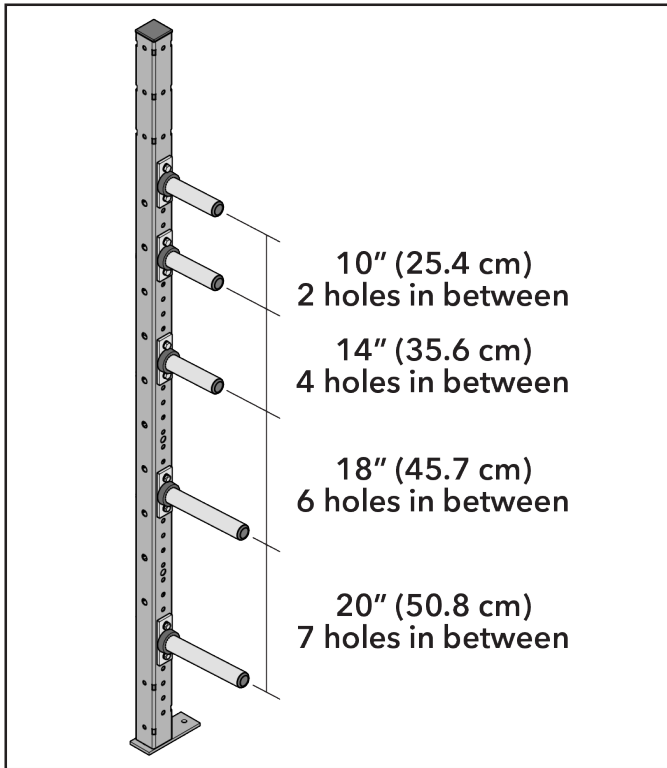

**5 Bull Horn
Olympic Plate Configuration**

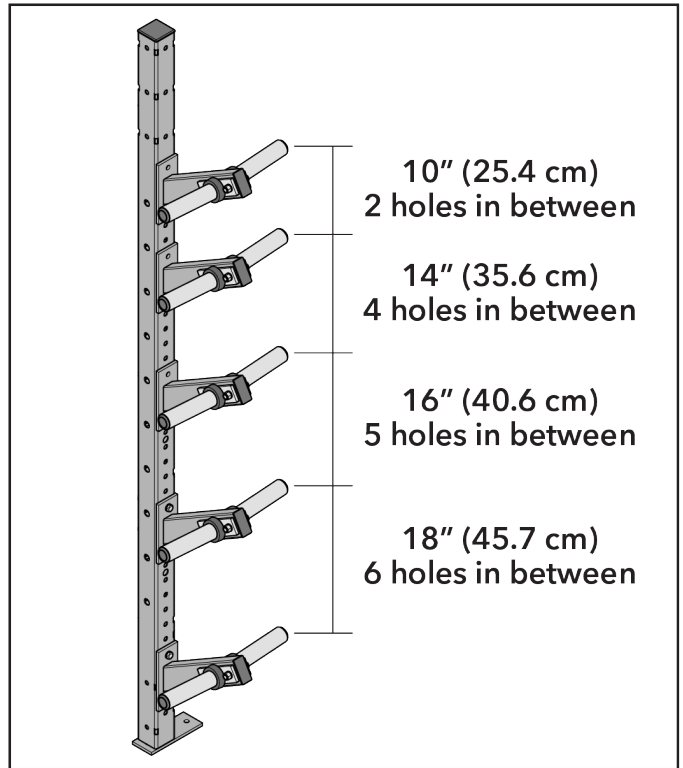

Weight Plate Storage

When adding and removing weight plates from weight horns, always evenly load and unload (left/right side) weight plates to avoid tipping.

Below is the recommended bumper plate storage configuration:

- (2) 10 lb plates
- (2) 25 lb plates
- (2) 45 lb plates
- (4) 45 lb plates

Below is the recommended Olympic plate storage configuration:

- (2) 2.5 lb or 5 lb plates
- (2) 10 lb plates
- (2) 25 lb plates
- (2) 45 lb plates
- (4) 45 lb plates

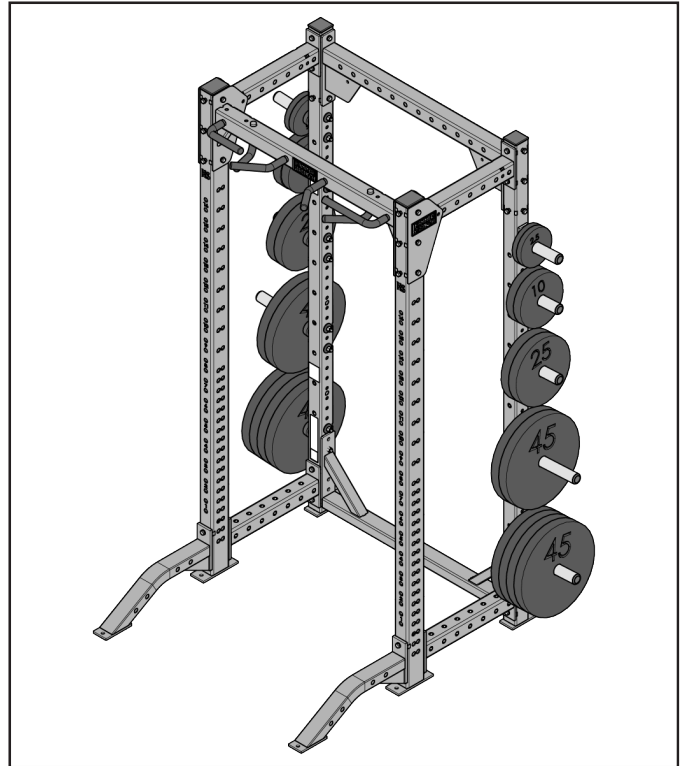
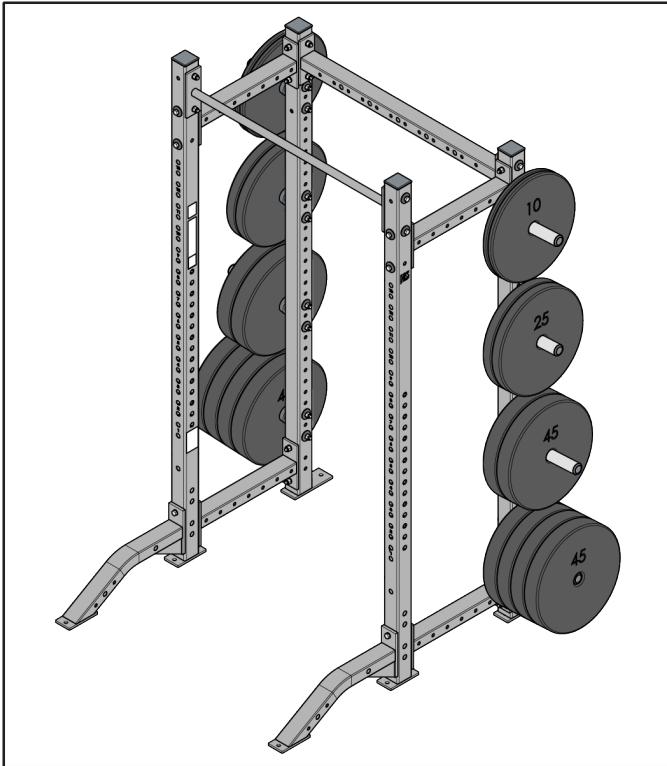

Install 42" / 72" Connectors

NOTE: 72" connectors shown for example.

Monkey Bar Connector

1. Remove lower bolt, backing washer, washer, and lock nut securing front crossmember to training upright on one rack using two 3/4" wrenches.

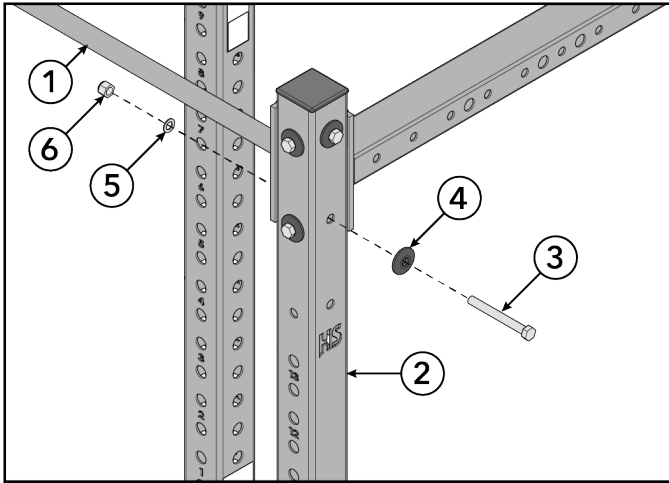

Item	Description	Qty.
1	Front Crossmember	1
2	Training Upright	1
3	Bolt, 1/2" x 4 1/2"	1
4	Backing Washer, 1/2"	1
5	Washer, 1/2"	1
6	Lock Nut, 1/2"	1

2. Repeat Step 1 to remove hardware from second rack.
3. Install bolts, washer, backing washer, step washers, and lock nuts securing monkey bar connector between training uprights of two racks using two 3/4" wrenches..

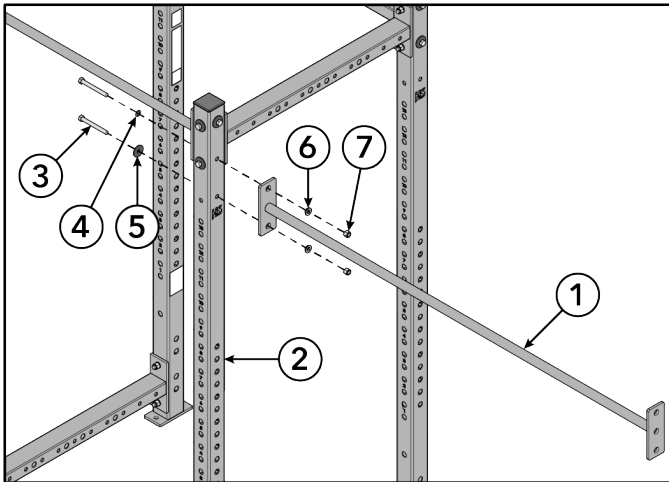

Item	Description	Qty.
1	Monkey Bar Connector	1
2	Training Upright	1
3	Bolt, 1/2" x 4 1/2"	2
4	Lock Washer, 1/2"	1
5	Backing Washer, 1/2"	1
6	Step Washer, 1/2"	2
7	Lock Nut, 1/2"	2



Tighten hardware to 20-25 ft-lb (27-34 Nm).

4. Repeat Step 3 to install monkey bar connector to second rack.

Square Connector

1. Remove lower bolt, backing washer, washer, and lock nut securing front crossmember to training upright on one rack using two 3/4" wrenches.

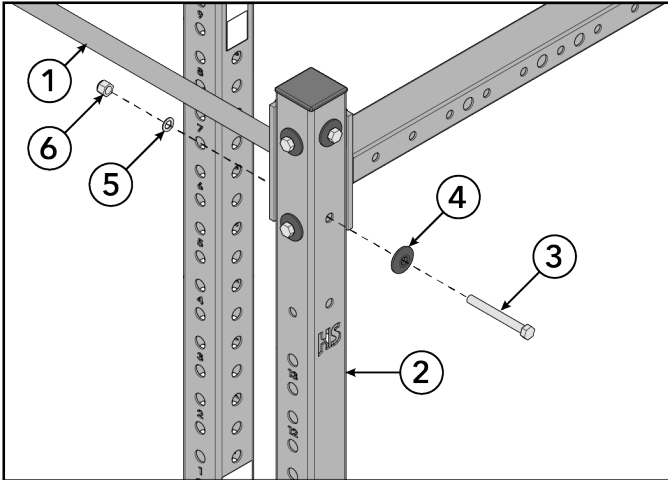

Item	Description	Qty.
1	Front Crossmember	1
2	Training Upright	1
3	Bolt, 1/2" x 4 1/2"	1
4	Backing Washer, 1/2"	1
5	Washer, 1/2"	1
6	Lock Nut, 1/2"	1

2. Repeat Step 1 to remove hardware from second rack.
3. Install bolts, washer, backing washer, step washers, and lock nuts securing square connector between training uprights of two racks using two 3/4" wrenches..

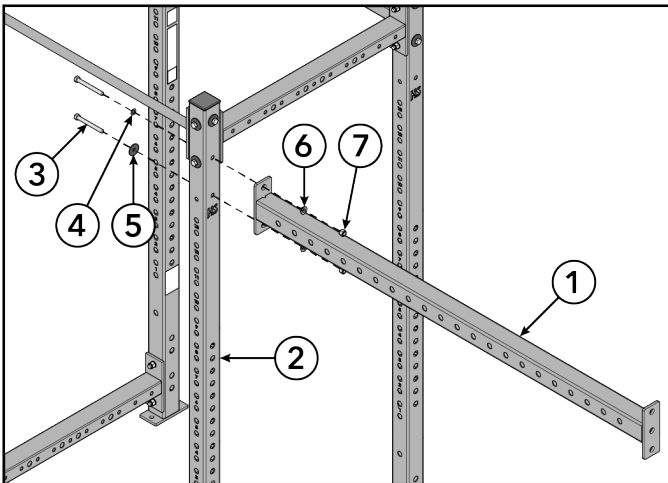

Item	Description	Qty.
1	Square Connector	1
2	Training Upright	1
3	Bolt, 1/2" x 4 1/2"	2
4	Lock Washer, 1/2"	1
5	Backing Washer, 1/2"	1
6	Step Washer, 1/2"	2
7	Lock Nut, 1/2"	2



Tighten hardware to 20-25 ft-lb (27-34 Nm).

4. Repeat Step 3 to install square connector to second rack.

Install 42" / 72" Storages

NOTE: 72" storages shown for example.

NOTE: When installing multiple storage options, leave a minimum of 10 open holes on storage uprights between storage options.

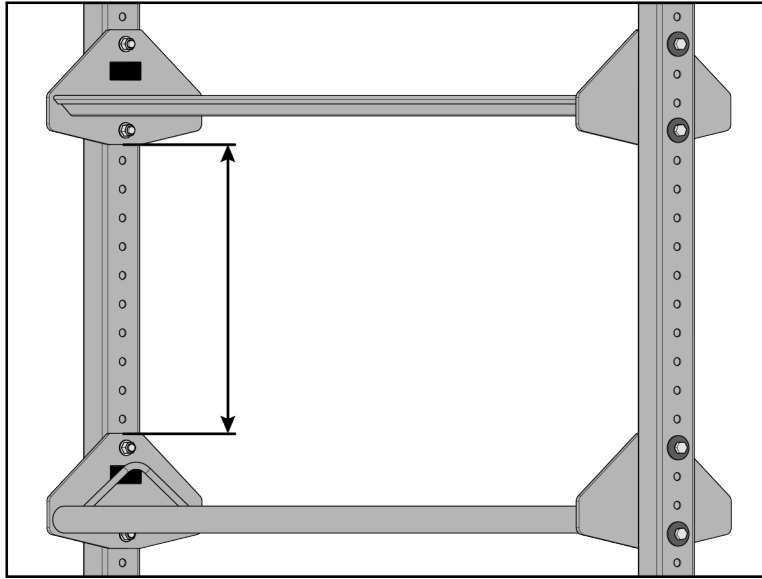

Accessory Tray Storage

Install bolts, backing washers, step washers, and lock nuts securing accessory tray storage between two storage uprights using two 3/4" wrenches.

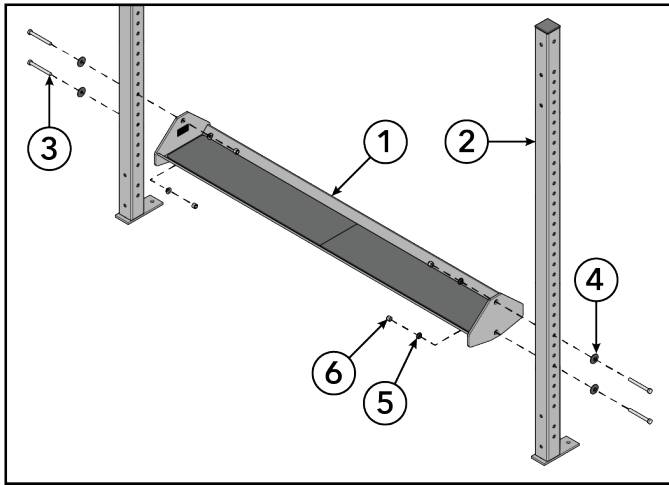

Item	Description	Qty.
1	Accessory Tray Storage	1
2	Storage Upright	2
3	Bolt, 1/2" x 4 1/2"	4
4	Backing Washer, 1/2"	4
5	Step Washer, 1/2"	4
6	Lock Nut, 1/2"	4



Tighten hardware to 20-25 ft-lb (27-34 Nm).

Dumbbell Tray Storage

Install bolts, backing washers, step washers, and lock nuts securing dumbbell tray storage between two storage uprights using two 3/4" wrenches.

NOTE: Dumbbell tray storage can be installed in two different positions.

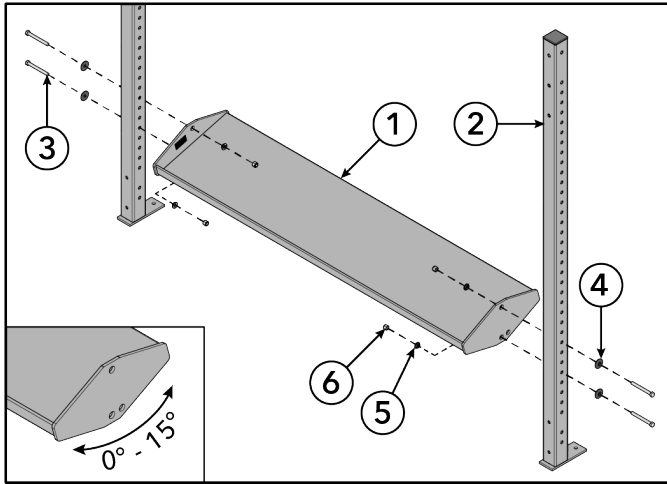

Item	Description	Qty.
1	Dumbbell Tray Storage	1
2	Storage Upright	2
3	Bolt, 1/2" x 4 1/2"	4
4	Backing Washer, 1/2"	4
5	Step Washer, 1/2"	4
6	Lock Nut, 1/2"	4



Tighten hardware to 20-25 ft-lb (27-34 Nm).

Stability Ball Storage

Install bolts, backing washers, step washers, and lock nuts securing stability ball storage between two storage uprights using two 3/4" wrenches.

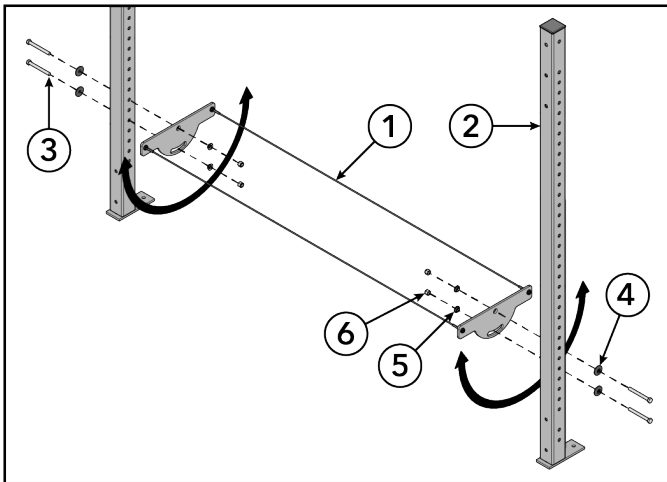

Item	Description	Qty.
1	Stability Ball Storage	1
2	Storage Upright	2
3	Bolt, 1/2" x 4 1/2"	4
4	Backing Washer, 1/2"	4
5	Step Washer, 1/2"	4
6	Lock Nut, 1/2"	4



Tighten hardware to 20-25 ft-lb (27-34 Nm).

Dual Rail Tray

Install bolts, backing washers, washers, and lock nuts securing dual rail tray between two storage uprights using two 3/4" wrenches.

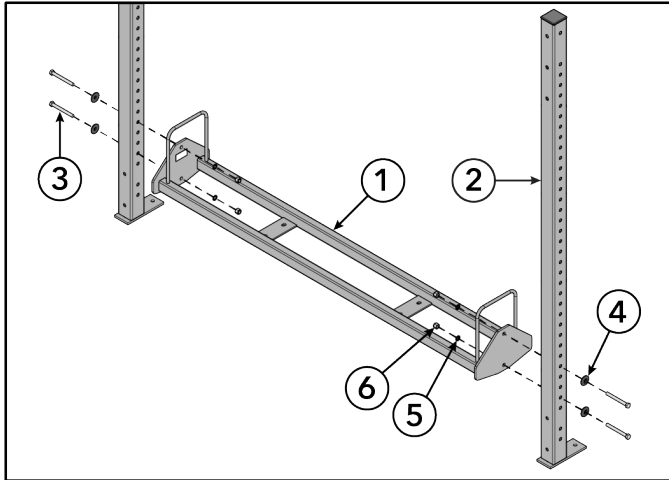

Item	Description	Qty.
1	Dual Rail Tray	1
2	Storage Upright	2
3	Bolt, 1/2" x 4 1/2"	4
4	Backing Washer, 1/2"	4
5	Lock Washer, 1/2"	4
6	Lock Nut, 1/2"	4



Tighten hardware to 20-25 ft-lb (27-34 Nm).

Dual Rail Bumper Plate Divider

NOTE: Dual rail plate dividers can only be installed on dual rail trays.

Install bolts, washers, and lock nuts securing dual rail bumper plate divider to dual rail tray using two 3/4" wrenches.

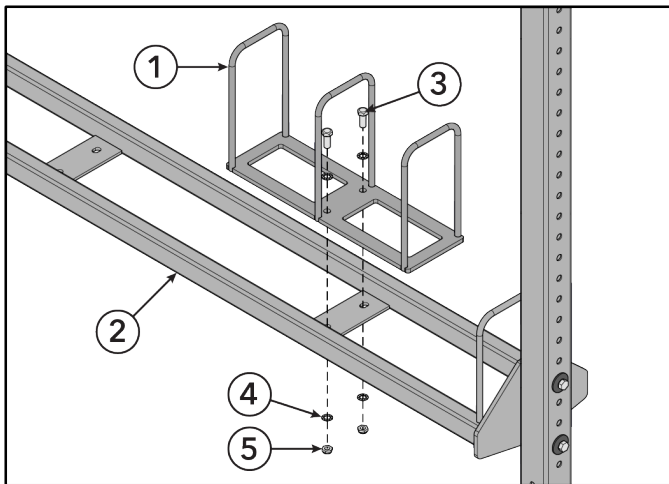

Item	Description	Qty.
1	Dual Rail Bumper Plate Divider	1
2	Dual Rail Tray	1
3	Bolt, 1/2" x 1 1/4"	2
4	Washer, 1/2"	4
5	Lock Nut, 1/2"	2



Tighten hardware to 20-25 ft-lb (27-34 Nm).

3. Maintenance Procedures

Maintenance Schedule

ACTION	DAILY	WEEKLY	MONTHLY	AS NEEDED
CLEAN				
Guide Rods			X	
Shrouds			X	
Hand Grips				X
WAX				
Frames				X
INSPECT				
Accessories		X		
Paint			X	
Cable	X			
Hardware		X		
Frame		X		
Shrouds	X			
LUBRICATE				
Guide Rods				X

Clean

- Guide rods with a cotton cloth.

Wax

- Frames with a standard, non-abrasive, wax finish.

Inspect

- Cables. Look for wear or damage and proper tension. Pay close attention at bends and attachment points.
- Hardware. Check for loosening. Tighten as required.
- Frames. Inspect for wear and damage.
- For paint chips. Fill in immediately with manufacturers touch-up paint.
- Jam nut at top of weight stack for tightness.

Lubricate

- Lubricate guide rods with Break-Free® brand lubricant (part number SK50-P0005-0000). Apply the lubricant to a cotton cloth, and then run the cotton cloth up and down the guide rods as needed.

NOTE: Only a few drops of lubricant are required for each guide rod.

Once a Day

- Wipe down upholstery with a mild soap and water or comparable all purpose cleaner.
- Visually inspect cables for wear at and around connections and along the entire length of the cable. Always replace at first sign of wear.

Once a Week

- Visually inspect all hardware for loosening, tampering or wear.
- Check jam nut at top of weight stack for tightness.
- Inspect all accessories, connecting links, and carabiner clips for wear.

- Check cables for stretch and adjust as necessary by loosening the large Jam Nut on top of the weight stack and by screwing in the Threaded Plug until cable is tight and the weight stack pin goes in all holes easily. Securely tighten the large Jam Nut when finished.
- Inspect shrouds for damage and clean as necessary.

Once a Month

- Clean guide rods with Break-Free® brand lubricant (part number SK50-P0005-0000). Clean tops of bearings at stack and inspect for heavy buildup on rods below the head plate. Lift half of stack and do a visual inspection, then clean as necessary.
- Inspect hardware on all machines and tighten any bolts or nuts that may have loosened over the life of the product.

Notes

- Use polishing compound (such as car wax) and remove shoe scuffs from powder coated surfaces as necessary.

Cleaning the Shrouds

- Adherence to regular and proper cleaning procedures is recommended to preserve the appearance.

NOTE: Spray the approved cleaner on a towel, and then wipe down the shrouds to avoid saturation of shroud inlays.

Minimize Scratches

- Wash the shrouds with an approved or compatible cleaner. Do not scrub brushes on the shrouds. Fresh paint splashes, grease and smeared glazing compounds can be removed easily before drying by rubbing lightly with isopropyl alcohol. Afterward, a warm final wash should be made.

Approved and Compatible Cleaners

Two preferred cleaners have been approved by reliability experts: PureGreen 24 and Gym Wipes. Both cleaners will safely and effectively remove dirt, grime and sweat from equipment. PureGreen 24 and the Antibacterial Force formula of Gym Wipes are both disinfectants that are effective against MRSA and H1N1.

PureGreen 24 is available in a spray which is convenient to use. Apply the spray to a microfiber cloth and wipe down the equipment. Use PureGreen 24 on the equipment for at least 2 minutes for general disinfection purposes and at least 10 minutes for fungus and viral control.

Gym Wipes are large, durable pre-moistened wipes to use on the equipment before and after workouts. Use Gym Wipes on the equipment for at least 2 minutes for general disinfection purposes.

Contact Customer Support Services to order these cleaners (1-800-351-3737 or email: customersupport@lifefitness.com).

Mild soap and water or a mild non-abrasive household cleaner can also be used to clean the display and all exterior surfaces. Use a soft microfiber cloth only. Apply the cleaner to the microfiber cloth before cleaning. DO NOT use ammonia or acid based cleaners. DO NOT use abrasive cleaners. DO NOT use paper towels. DO NOT apply cleaners directly to the equipment surfaces.

Removal of Paint, Marking Pens, or Labels

- Butyl cellosolve works well for removal of paints, marking pen inks, lipstick, etc.
- Labels, stickers, etc. may be removed using kerosene. When the solvent will not penetrate sticker material, apply heat (hair dryer) to soften the adhesive and promote removal. GASOLINE SHOULD NOT BE USED.

Important Hazards

- DO NOT use abrasive or highly alkaline cleaners on the shrouds.
- NEVER scrape shrouds with squeegees, razor blades or other sharp instruments.
- DO NOT clean shrouds in hot sun or at elevated temperatures.
- NEVER use benzene, gasoline, acetone or carbon tetrachloride on the shrouds.
- Manufacturer recommends that cables be inspected daily after installation and replaced annually.

4. Warranty

What is Covered

This Life Fitness commercial exercise equipment product is warranted to be free of all defects in material and workmanship.

Who is Covered

The original purchaser or any person receiving the product as a gift from the original purchaser.

Who Pays Transportation and Insurance For Service

If the Product or any covered part must be returned to a service facility for repairs, We, Life Fitness, will pay all transportation and insurance charges for the first year. You are responsible for transportation and insurance charge after the first year.

What We Will Do To Correct Covered Defects

We will ship to you any new or rebuilt replacement part or component, or at our option, replace the Product. Such replacement parts are warranted for the remaining portion of the original warranty period.

What is Not Covered

Any failures or damage caused by unauthorized service, misuse, accident, negligence, improper assembly or installation, debris resulting from any construction activities in the Product's environment, rust or corrosion as a result of the Product's location, alterations or modifications without our written authorization, or by failure on your part to use, operate and maintain the Product as set out in your Operation Manual.

All terms of this warranty are void if this product is moved beyond the continental borders of the United States of America (excluding Alaska, Hawaii and Canada) and are then subject to the terms provided by that country's local authorized Life Fitness representative.

Owner's Manual

It is VERY IMPORTANT THAT YOU READ THIS MANUAL before operating the Product. Remember to perform the periodic maintenance requirements specified in the Manual to assure proper operation and your continued satisfaction.

Exclusive Warranty

THIS LIMITED WARRANTY IS IN LIEU OF ALL OTHER WARRANTIES OF ANY KIND EITHER EXPRESSED OR IMPLIED, INCLUDING BUT NOT LIMITED TO THE IMPLIED WARRANTIES OF MERCHANTABILITY AND FITNESS FOR A PARTICULAR PURPOSE, AND ALL OTHER OBLIGATIONS OR LIABILITIES ON OUR PART. We neither assume nor authorize any person to assure for us any other obligation or liability concerning the sale of this Product. Under no circumstances shall we be liable under this warranty, or otherwise, of any damage to any person or property, including any lost profits or lost savings, for any special, indirect, secondary, incidental or consequential damages of any nature arising out of the use of or inability to use this Product. Some states do not allow the exclusion or limitation of implied warranties or of liability for incidental or consequential damages, so the above limitations or exclusions may not apply to you. Warranty coverages and terms may differ outside the United States. Please contact the Life Fitness office servicing your country (contact information found at the front of this manual) or visit the applicable local Life Fitness website to receive the specific warranty information for your country.

Changes in Warranty Not Authorized

No one is authorized to change, modify or extend the terms of this limited warranty.

Effects of State Laws

This warranty gives you specific legal rights, and you may have other rights which vary from state to state and country by country.

Warranty Coverage

NOTE: There is no warranty coverage for labor on Strength Products.

Item	5 Years	3 Years	1 Year	90 Days
Frame	X			
Hardware / Mechanical				X
Items Not Specified				X

How to Obtain Product Service

For CUSTOMER Service within the United States and Canada: 1-800-351-3737 or customersupport@lifefitness.com

Please call Monday through Friday from 7:00 a.m. to 6:00 p.m. Central Standard Time, and tell them your name, address, and serial number of your Product. They will tell you how to get a replacement part, or if necessary, arrange for service where your Product is located or advise you on how and where to ship the Product for service. Before shipping:

1. **Obtain** a Return Authorization Number (**RA#**) from Customer Support Services
2. Securely **pack** your Product (use the original shipping carton, if possible)
3. **Write** the RA# on the outside of the carton
4. **Insure** the Product
5. **Include** a letter explaining the defect or problem and a copy of your proof of purchase if you believe the service is covered by warranty.

Return address:

Life Fitness World Headquarters

Attn: CSS Help Desk

10601 W Belmont Ave

Franklin Park, IL 60131

For Product Service Internationally see contact information listed on page two of this manual.

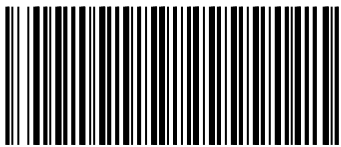

1020648-0001