

HAMMER[®]STRENGTH

HAMMER STRENGTH[®]

Heavy Duty Athletic NX Racks Owner's Manual

HDW-HR, HDW-HR-STRD, HDW-HR8-STRD, HDW-HHCR, HDW-PR,
HDW-PR-STRD, HDW-PR8-STRD, HDW-PHCR, HDW-PPCR, HDW-SQST



Corporate Headquarters

Columbia Centre III, 9525 Bryn Mawr Avenue, Rosemont, IL 60018 • U.S.A.
847.288.3300 • FAX: 847.288.3703
Service phone number: 800.351.3737 (toll-free within U.S.A., Canada)
Global Website: www.lifefitness.com

International Offices

AMERICAS

North America

Life Fitness, LLC

Columbia Centre III
9525 Bryn Mawr Avenue
Rosemont, IL 60018 U.S.A.
Telephone: (847) 288 3300
Service Email:
customersupport@lifefitness.com
Sales/Marketing Email:
commercialsales@lifefitness.com

Brazil

Life Fitness Brasil

Av. Rebouças, 2315
Pinheiros
São Paulo, SP 05401-300
BRAZIL
SAC: 0800 773 8282 option 2
Telephone: +55 (11) 3095 5200 option 2
Service Email: suportebr@lifefitness.com
Sales/Marketing Email:
vendasbr@lifefitness.com

Latin America and Caribbean*

Life Fitness, LLC

Columbia Centre III
9525 Bryn Mawr Avenue
Rosemont, IL 60018 U.S.A.
Telephone: (847) 288 3300
Service Email:
customersupport@lifefitness.com
Sales/Marketing Email:
commercialsales@lifefitness.com

EUROPE, MIDDLE EAST, and AFRICA (EMEA)

Belgium, Netherlands, and Luxemburg

Life Fitness (Atlantic) B.V.

Fascinatio Boulevard 230, 4th Fl - Bldg B
3065WB, Rotterdam
The Netherlands
+31 88 646 6666
Service Email:
service.belux@lifefitness.com
Sales/Marketing Email:
marketing.belux@lifefitness.com

United Kingdom

Life Fitness UK LTD

Unit 109^a
Lancaster Way Business Park
Ely, Cambs, CB6 3NX
Telephone: General Office (+44)
1353.666017
Customer Support (+44) 1353.665507
Service Email: uk.support@lifefitness.com
Sales/Marketing Email: life@lifefitness.com

Germany, Austria, and Switzerland

Life Fitness Europe GMBH

Neuhofweg 9
85716 Unterschleißheim
GERMANY
Telephone:
+49 (0) 89 / 31775166 Germany
+43 (0) 1 / 6157198 Austria
+41 (0) 848 / 000901 Switzerland
Service Email:
kundendienst@lifefitness.com
Sales/Marketing Email:
vertrieb@lifefitness.com

Spain

Life Fitness IBERIA

C/Frederic Mompou 5,1^o^a
08960 Sant Just Desvern Barcelona
SPAIN
Telephone: (+34) 93.672.4660
Service Email:
servicio.tecnico@lifefitness.com
Sales/Marketing Email:
info.iberia@lifefitness.com

All Other EMEA Countries and Distributor Business EMEA*

Life Fitness (Atlantic) B.V.

Fascinatio Boulevard 230, 4th Fl - Bldg B
3065WB, Rotterdam
The Netherlands
+31 88 646 6666
Service Email:
emeaservicesupport@lifefitness.com

ASIA PACIFIC (AP)

Japan

Life Fitness Japan, Ltd

4-17-33 Minami Aoyama 1F/B1F
Minato-ku - Tokyo 107-0062
Japan
Telephone: (+81) 0120.114.482
Fax: (+81) 03-5770-5059
Service Email: service.lfj@lifefitness.com
Sales/Marketing Email:
sales@lifefitnessjapan.com

Hong Kong

Life Fitness Asia Pacific LTD

26/F, Global Trade Square
21 Wong Chuk Hang Road
Wong Chuk Hang
Hong Kong
Telephone: (+852) 25756262
Fax: (+852) 25756894
Service Email: service.hk@lifefitness.com
Sales/Marketing Email:
marketing.hk.asia@lifefitness.com

All Other Asia Pacific countries and distributor business Asia Pacific*

Life Fitness Asia Pacific LTD

26/F, Global Trade Square
21 Wong Chuk Hang Road
Wong Chuk Hang
Hong Kong
Telephone: (+852) 25756262
Fax: (+852) 25756894
Service Email: service.ap@lifefitness.com
Sales/Marketing Email:
marketing.hk.asia@lifefitness.com

*Also check www.lifefitness.com for local representation or distributor/dealer

User and Service Documents Link

<https://fn.fit/KnowledgeBase>

<https://fn.fit/PartStore>

Additional information is available online using the links above.

تتوفر معلومات إضافية على الإنترنت باستخدام الرابط أعلاه.

点击上面的链接可在线获取更多信息。

Flere oplysninger er tilgængelige online gennem linket ovenfor.

Bijkomende informatie is online beschikbaar via bovenstaande link.

Vous trouverez plus d'informations en ligne à l'aide du lien ci-dessus.

Zusätzliche Informationen finden Sie online über den oben angegebenen Link.

Ulteriori informazioni sono disponibili online utilizzando il link sopra riportato.

追加情報は上記リンクを使用してオンラインで利用可能です。

상기 링크를 통해 온라인에서 추가 정보를 볼 수 있습니다.

Informações adicionais estão disponíveis on-line, através do link acima.

Дополнительная информация доступна в интернете по ссылке, указанной выше.

Mediante el enlace anterior podrá acceder a información adicional en línea.

Ytterligare information finns online genom att använda länken ovan.

İnternet üzerinden daha fazla bilgi edinmek için yukarıdaki bağlantıyı kullanabilirsiniz.

هناك معلومات إضافية متاحة على الإنترنت باستخدام الرابط أعلاه.

Informazio osagarria eskuragarri dago goiko estekaren bidez.

Допълнителна информация можете да намерите онлайн, като използвате връзката по-горе.

Mitjançant l'enllaç anterior podreu accedir a informació addicional en línia.

使用上面的連結線上提供額外資訊。

Dodatne informacije možete pronaći na internetu sljedeći vezu iznad.

ከላይ የተመጠውን አገናኝ(ሊንክ) በመጠቀም መረጃዎች አንላይን ያገኛሉ።

Lisätietoja on saatavissa verkosta käyttämällä yllä olevaa linkkiä.

Wubetumi anya nsem afoforo aka ho wa websait so denam asem a ewo atifi ho a wubemia so so.

Πρόσθετες πληροφορίες είναι διαθέσιμες ονλάιν χρησιμοποιώντας το σύνδεσμο παραπάνω.

מידע נוסף אפשר לקבל באתר האינטרנט באמצעות הקישור לעיל.

További információ elérhető online, a fenti hivatkozás segítségével.

Viðbótarupplýsingar eru fáanlegar á netinu með því að smella á tengilinn hér fyrir ofan.

Plus indicium per superum situm potes invenire.

മുകളിലുള്ള ലിങ്ക് ഉപയോഗിച്ച് ഓൺലൈനിൽ കൂടുതൽ വിവരങ്ങൾ ലഭ്യമാണ്.

Ytterligere informasjon er tilgjengelig på nettet via linken ovenfor.

Dodatkowe informacje są dostępne online pod powyższym odnośnikiem.

Informações adicionais estão disponíveis online a usar o link acima.

Informații suplimentare sunt disponibile online, utilizând link-ul de mai sus.

Dodatne informacije dostupne su na mreži putem gornjeg linka.

Ďalšie informácie sú dostupné online na vyššie uvedenom odkaze.

Table of Contents

Safety

Safety Information.....	7
Product Labels.....	9
Label Locations.....	10

Assembly

Introduction.....	15
Component and Hardware List.....	15
Tools Required.....	19
Assembly Procedure.....	20
Squat Stand (HDW-SQST).....	20
Assemble Squat Stand.....	20
Component List.....	23
Half Rack (HDW-HR).....	24
Assemble Half Rack.....	24
Component List.....	27
Power Rack (HDW-PR).....	29
Assemble Power Rack.....	29
Install Additional Storage Uprights.....	32
Component List.....	35
Combo Rack (HDW-HHCR, HDW-PHCR, HDW-PPCR).....	37
Assemble Combo Rack.....	38
Component List.....	45
Optional Components.....	46
Weight Plate Storage.....	46
Install Weight Horns.....	47
Install Flexible Bar Catches.....	48
Install Custom Sign.....	49

Product Information

Squat Stand (HDW-SQST).....	50
Half Rack (HDW-HR, HDW-HR-STRD and HDW-HR8-STRD).....	51
Power Rack (HDW-PR, HDW-PR-STRD and HDW-PR-STRD).....	52
Combo Rack (HDW-HHCR, HDW-PHCR, HDW-PPCR).....	53

Exercise

General Exercise Information.....	58
-----------------------------------	----

Maintenance Procedures

Maintenance Schedule.....	59
---------------------------	----

Warranty

What is Covered.....	61
Who is Covered.....	61
Who Pays Transportation and Insurance For Service.....	61
What We Will Do To Correct Covered Defects.....	61
What is Not Covered.....	61
Owner's Manual.....	61
Exclusive Warranty.....	61
Changes in Warranty Not Authorized.....	61
Effects of State Laws.....	61

Life Fitness® is a registered trademark.

Gym Wipes® is a registered trademark of the 2XL Corporation. PureGreen 24 is a trademark of Pure Green.

© Copyright 2025, Life Fitness, LLC. All Rights Reserved. Life Fitness, Hammer Strength, Cybex, ICG and SCIFIT are registered trademarks of Life Fitness, LLC and its affiliated companies and subsidiaries. Disclaimer: Images and specifications are current as of the date of publication and are subject to change.

Columbia Center III - 9525 Bryn Mawr Ave., Rosemont, IL 60018 • 847-288-3300 • www.lifefitness.com • 1020647-0001 AE • 2025

Terms of Warranty Coverage..... 61

Cable Handling Guide

Cable Connections, Seating, and Installation..... 63
Cabling Procedure..... 63
Tensioning Cable..... 65
Strength Cable Wear Guide..... 65
Insert Inspection..... 66

Bolt to Floor Guide

Introduction..... 68
Delivery and Installation Tips..... 68
Anchor Type - Static..... 69
Anchor Type - Dynamic..... 69
Anchor Specifications..... 69
Pullout Force..... 70
Tools Required..... 70
Anchor Procedure..... 71
Foot Dimensions..... 73

Life Fitness® is a registered trademark.

Gym Wipes® is a registered trademark of the 2XL Corporation. PureGreen 24 is a trademark of Pure Green.

© Copyright 2025, Life Fitness, LLC. All Rights Reserved. Life Fitness, Hammer Strength, Cybex, ICG and SCIFIT are registered trademarks of Life Fitness, LLC and its affiliated companies and subsidiaries. Disclaimer: Images and specifications are current as of the date of publication and are subject to change.

Columbia Center III - 9525 Bryn Mawr Ave., Rosemont, IL 60018 • 847-288-3300 • www.lifefitness.com • 1020647-0001 AE • 2025

1. Safety

Safety Information

It is the sole responsibility of the purchaser of Life Fitness products to read the owner's manual and warning labels and instruct all individuals, whether they are the end user or supervising personnel, on proper usage of the equipment.

UNDERSTANDING EACH AND EVERY WARNING TO THE FULLEST IS IMPORTANT. IF ANY OF THESE WARNINGS ARE UNCLEAR, CONTACT Life Fitness CUSTOMER SERVICE IMMEDIATELY AT 1-800-351-3737.

This equipment is categorized as class S per EN ISO 20957-1. As such this equipment is only intended for commercial, institutional and/or studio facilities. It is not intended for home use. Contact Life Fitness with any questions regarding this classification.

It is recommended that all users of Life Fitness exercise equipment be informed of the following information prior to use.

Operating Warnings

⚠ WARNING: This product can expose you to chemicals including 1,3 Butadiene, which is known to the State of California to cause cancer and birth defects or other reproductive harm. For more information go to <http://www.P65Warnings.ca.gov>

- Life Fitness does not warrant nor guarantee that component parts used in the manufacture of products offered under the Life Fitness brand are latex-free. Users of these products must take all necessary precautions to prevent accidental contact that could lead to an adverse latex reaction.
- It is the purchaser's sole responsibility to properly instruct its end users and supervising personnel as to the proper operating procedures of all equipment.
- This equipment is not intended for use by children. Keep children under the age of 14 away from the machine.
- Do not allow users to wear loose fitting clothing or jewelry while using equipment. It is also recommended to have users secure long hair back and up to avoid contact with moving parts.
- All bystanders must stay clear of all users, moving parts and attached accessories and components while machine is in operation.

Access Control

- Life Fitness recommends that all commercial fitness equipment be used in a supervised area. It is recommended that the equipment be located in an access controlled area. Control is the responsibility of the facility owner.

Installation

- Life Fitness requires that all equipment be secured to a solid, level surface to stabilize it and eliminate rocking or tipping over. This must be performed by a licensed contractor. See [Bolt to Floor Guide](#) for installation procedure.
- Life Fitness requires that all Athletic Racks be secured to the floor when used with body weight strap training devices to stabilize and eliminate rocking or tripping over. If necessary, please contact [Customer Support Services](#) for any questions.

Proper Usage

- Do not use any equipment in any way other than as designed or intended by the manufacturer. It is imperative that Life Fitness equipment is used properly to avoid injury.
- Injuries may result if exercising improperly or excessively. It is recommended that all individuals consult a physician prior to commencing an exercise program. If at any time during exercise you feel faint, dizzy or experience pain, STOP EXERCISING and consult your physician.
- Keep body parts (hands, feet, hair, etc.), clothing and jewelry away from moving parts to avoid injury.

Inspection

- Before use, examine all accessories approved for use with the Life Fitness equipment for damage or wear.
- DO NOT attempt to use or repair any accessory approved for use with the equipment which appears to be damaged or worn.
- DO NOT use or permit use of any equipment that is damaged and/or has worn or broken parts. For all Life Fitness equipment, use only replacement parts supplied by Life Fitness.
- Maintain labels, name plates and instructional placards. Do not remove labels or instructional placards for any reason. They contain important information. Contact Customer Support to replace any worn, damaged, or unreadable labels or instructional placards and to ensure that you are always using the latest version of labels and instructional placards.

- Equipment Maintenance - Preventative maintenance is the key to smooth operating equipment as well as to keep your liability to a minimum. Equipment needs to be inspected at regular intervals.
- Ensure that any person(s) making adjustments or performing maintenance or repair of any kind is qualified to do so. Life Fitness will provide service and maintenance training at our corporate facility upon request or in the field if proper arrangements are made.

Plate Loaded, Free Weight, and Body Weight Systems

- If the unit is equipped with weight rods, use only Olympic style weight plates (2.0" bore) for training weight. Do not use dumbbells or any means other than those stated to increase weight resistance - See machine specific section for more information.
- Always utilize weight plate retention devices such as straps, clamps or pins.
- Only add weight plates up to the load limits of the unit. Make sure all weight plates are completely placed on the weight rod.
- Never exceed the load rating for any plate loaded station, body weight station, bench or other free weight device; including specific weight rod and band peg limits. See machine specifications for load limit information.
- Contact a Life Fitness representative with any questions regarding proper weights and loading.

Warnings and Cautions

- Warning labels indicate a potentially hazardous situation that could result in serious injury or death if the precautions are not observed.
- Caution labels indicate a potentially hazardous situation that could result in serious injury or damage to machine if the precautions are not observed.
- Contact [Customer Support Services](#) to replace any worn, damaged, or unreadable labels and to ensure that you are always using the latest version of labels.

Product Labels

Installers to verify that all labels are accounted for. Replace any labels that are missing or damaged.

General Warning

! **WARNING**

SERIOUS INJURY CAN OCCUR ON THIS EQUIPMENT. YOU MUST FOLLOW THESE PRECAUTIONS TO AVOID INJURY!

- Before using, read all the warnings and obtain instructions on the use of this machine. Use only for intended exercise. **DO NOT** modify the machine.
- Obtain a medical exam before beginning any exercise program.
- Keep body, hair, and clothing free of all moving objects.
- Inspect machine and attachments before use. **DO NOT** use if the machine or attachments appear damaged. **DO NOT** attempt to fix broken or jammed machine or damaged attachments. Notify staff immediately.
- Children must not be allowed near this machine. Supervise teenagers.
- DO NOT** exceed the load rating. Seek Assistance.
- Manufacturer recommends that all equipment be secured to the floor to stabilize and eliminate rocking or tipping over. Use a licensed contractor.
- REQUIRED** Bolt to floor if training with bands or using suspension training devices.
- ALWAYS** use bar catches or have a spotter when performing lifts.
- DO NOT** offset flexible bar catches more than three hole positions.
- DO NOT REMOVE THIS LABEL. REPLACE IF DAMAGED.**

1020225-0001

Serial Number

HAMMER STRENGTH

9525 Bryn Mawr Ave Rosemont, IL 60018 USA 1-847-288-3300 www.lifefitness.com	Bijdorplan 25-31 2992 LB Barendrecht The Netherlands +31 0 180 646 666	CAGE: OCMY5 Class: S
---	---	----------------------------

Model:
XXX

Max User Wt:	XXXlbs	XXXkgs
Max Training Wt:	XXXlbs	XXXkgs
Max Storage Wt:	XXXlbs	XXXkgs

SN: XXXXXXXXXXXXX

Manufactured in the USA with US and Foreign parts

Max Training, 405 LB

MAX
405 lbs.
(184 kg.)

Max Training, 495 LB

MAX
495 lbs.
(224 kg.)

QR Code

i

Bar Catch Height

! **WARNING**

28in+ (71cm+)

Label Locations
Bar Catches

Standard HR Bar Catch

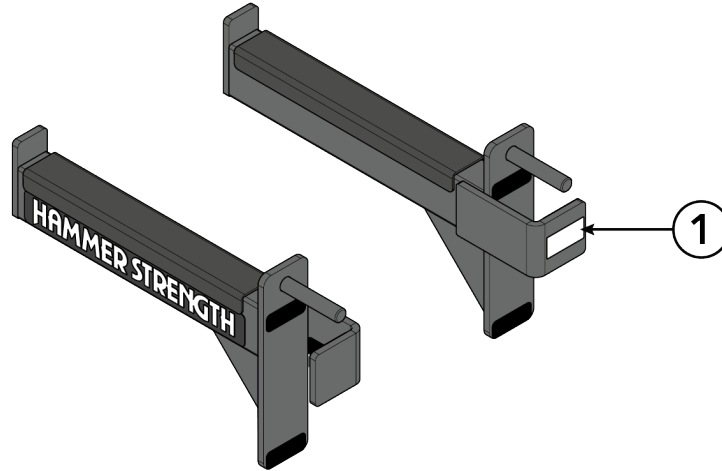

Premium HR Bar Catch

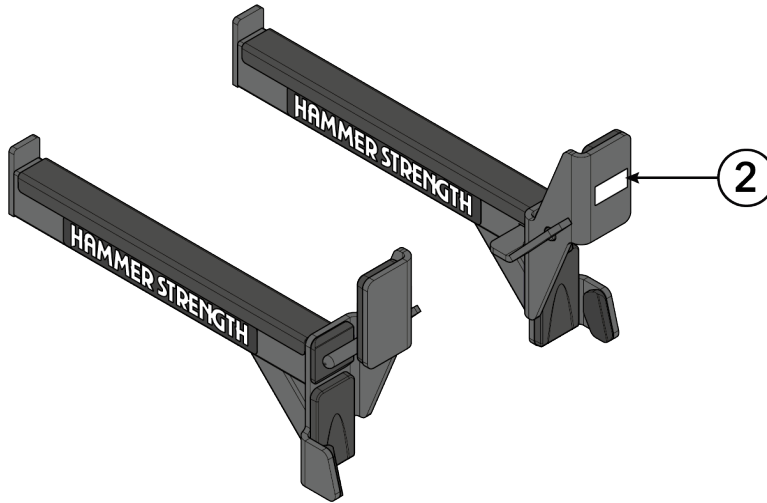

Item	Description	Qty.
1	Max Training, 405 LB	1
2	Max Training, 495 LB	1

Combo Rack (HDW-HHCR, HDW-PHCR, HDW-PPCR)

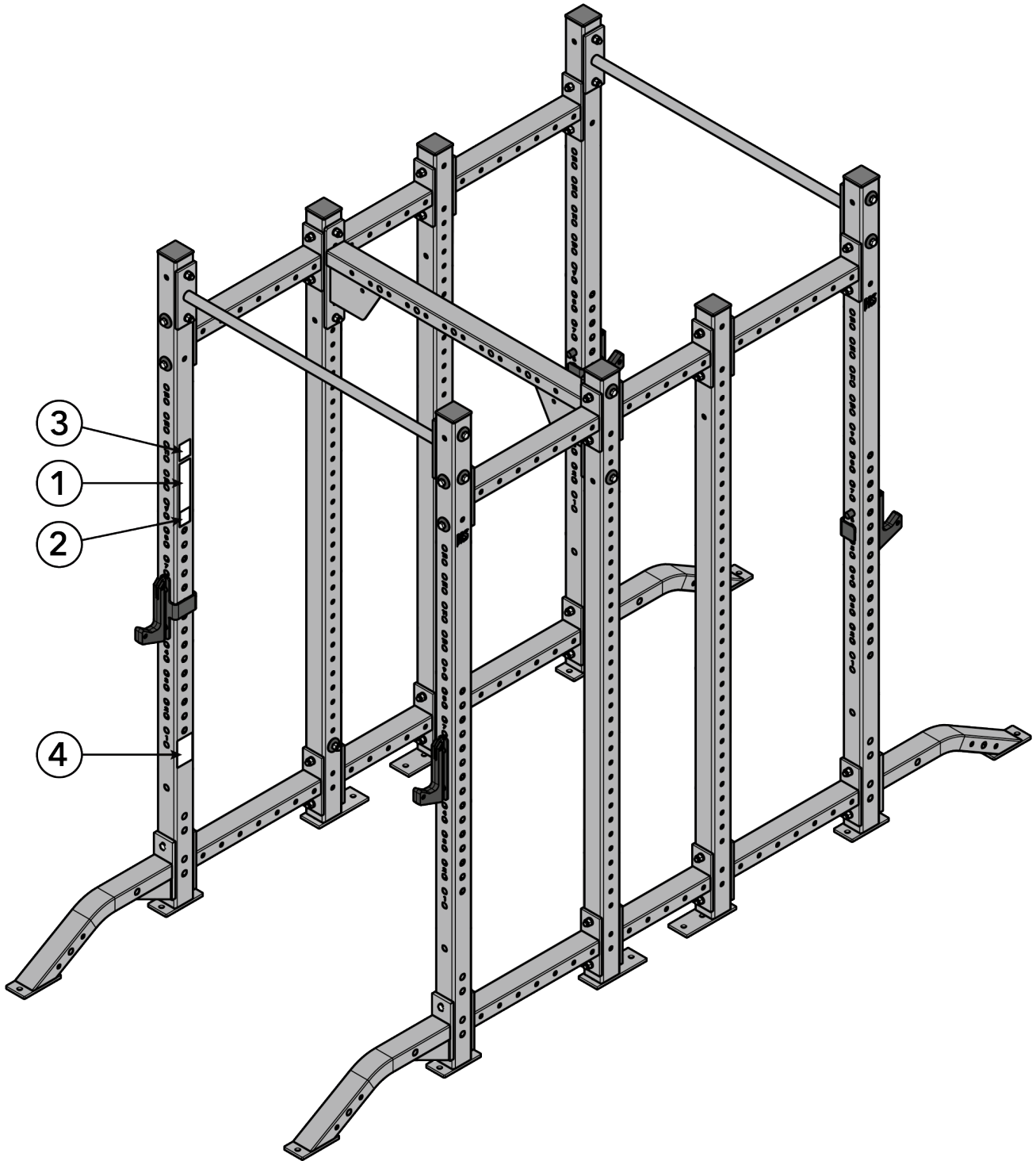

Item	Description	Qty.
1	General Warning	2
2	Serial Number	2
3	QR Code	2
4	Bar Catch Height	2

Half Rack (HDW-HR, HDW-HR-STRD and HDW-HR8-STRD)

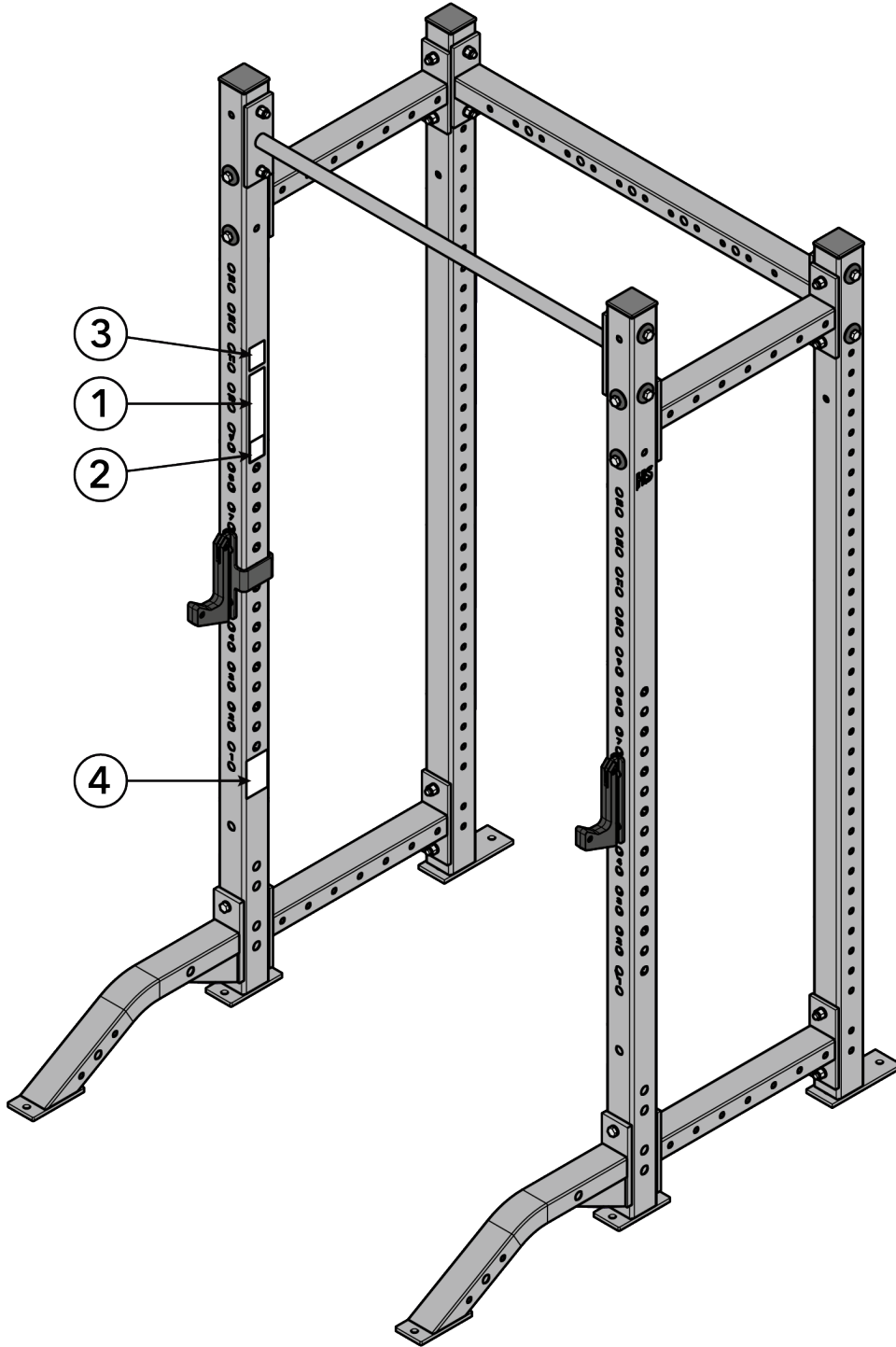

Item	Description	Qty.
1	General Warning	1
2	Serial Number	1
3	QR Code	1
4	Bar Catch Height	1

Power Rack (HDW-PR, HDW-PR-STRD and HDW-PR8-STRD)

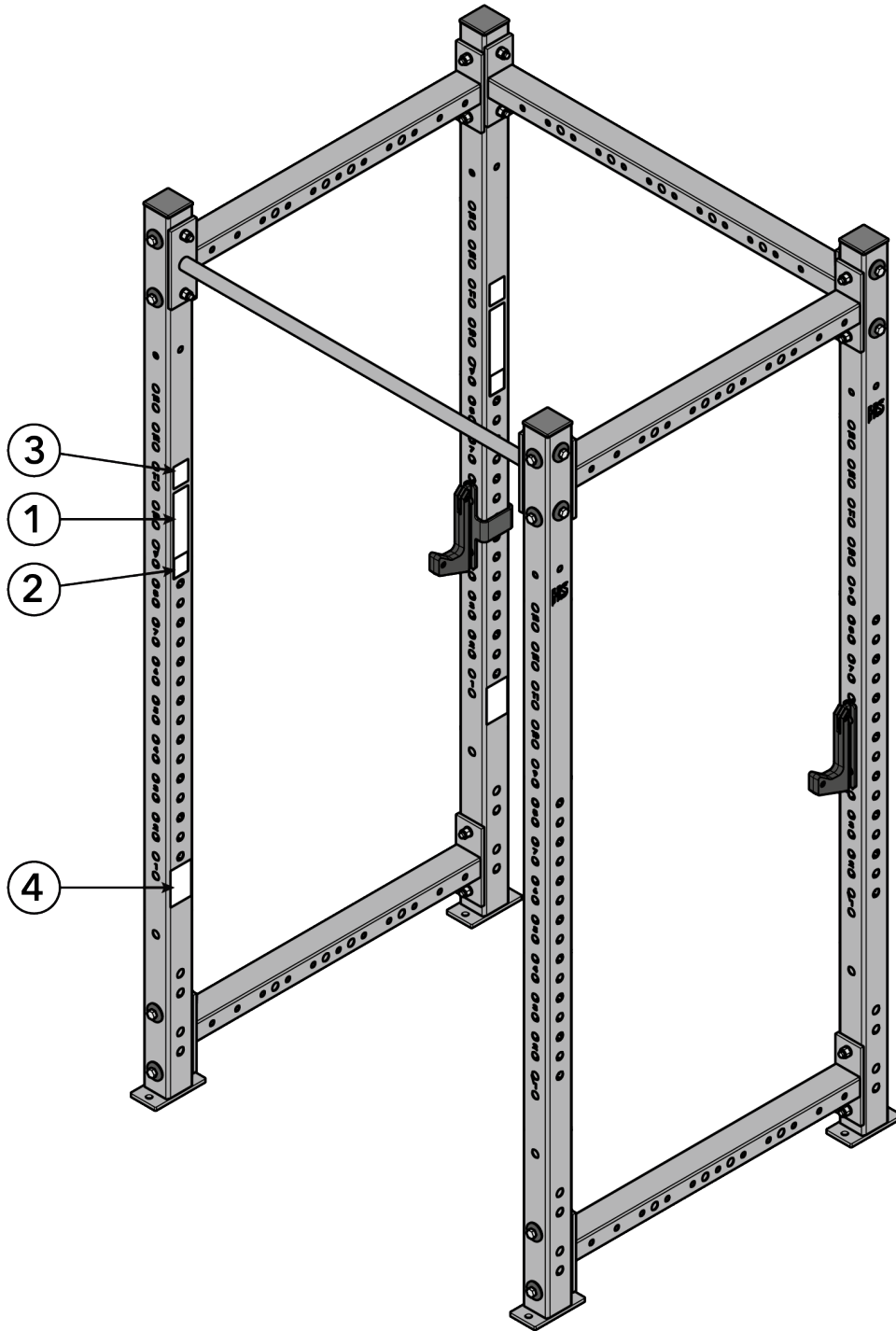

Item	Description	Qty.
1	General Warning	2
2	Serial Number	2
3	QR Code	2
4	Bar Catch Height	2

Squat Stand (HDW-SQST)

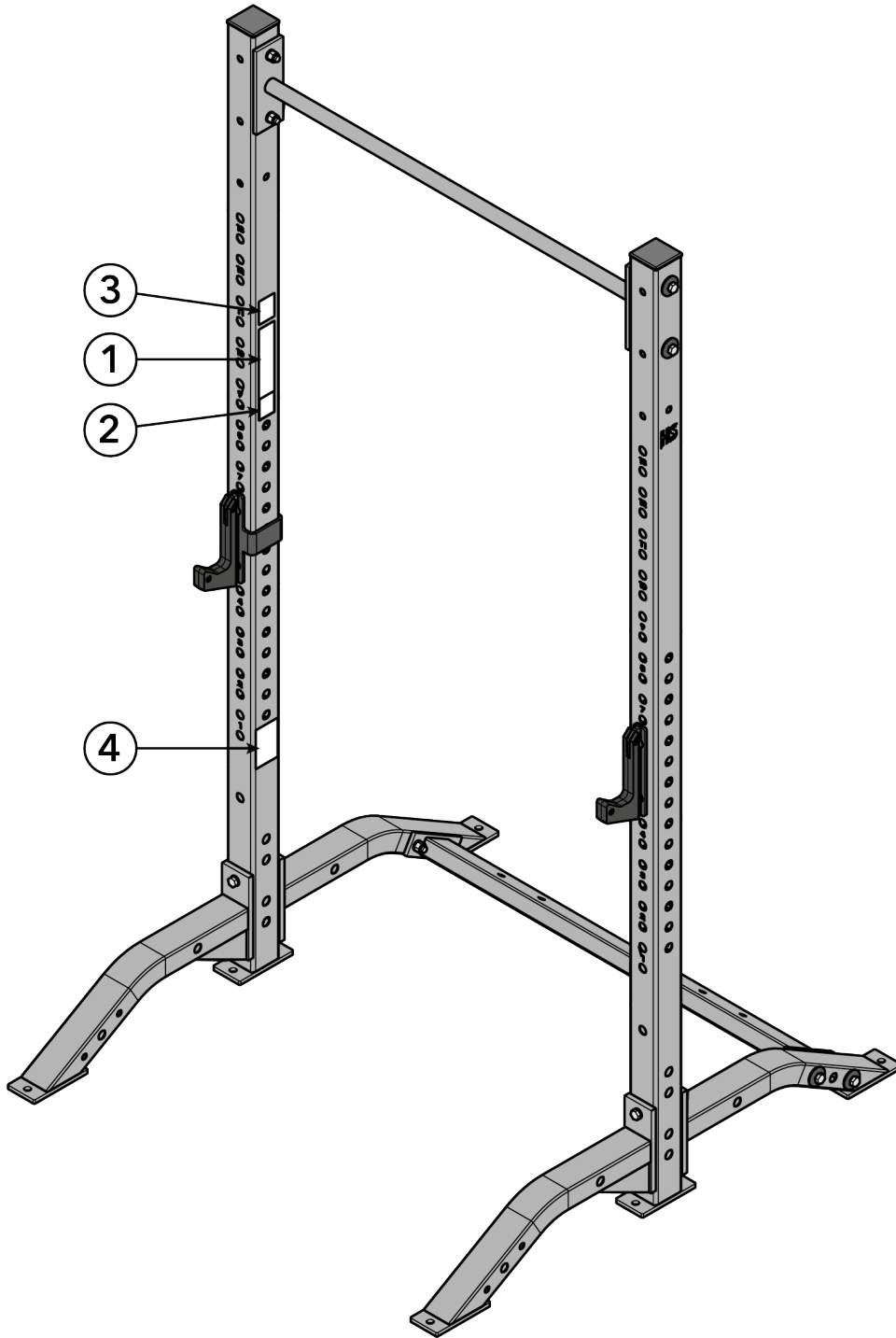

Item	Description	Qty.
1	General Warning	1
2	Serial Number	1
3	QR Code	1
4	Bar Catch Height	1

2. Assembly

Introduction

The Installer must consult the Facility Owner prior to assembly for determining the following:

1. Required Facility layout and live area
2. Which way exercisers will be entering the product (ex. power lifting or free weight bench) for proper label placement
3. Weight horn placement based on available weight plates. See [Install Weight Horns](#) and [Weight Plate Storage](#) topics for more details.

Component and Hardware List

Bar Catches and Supports

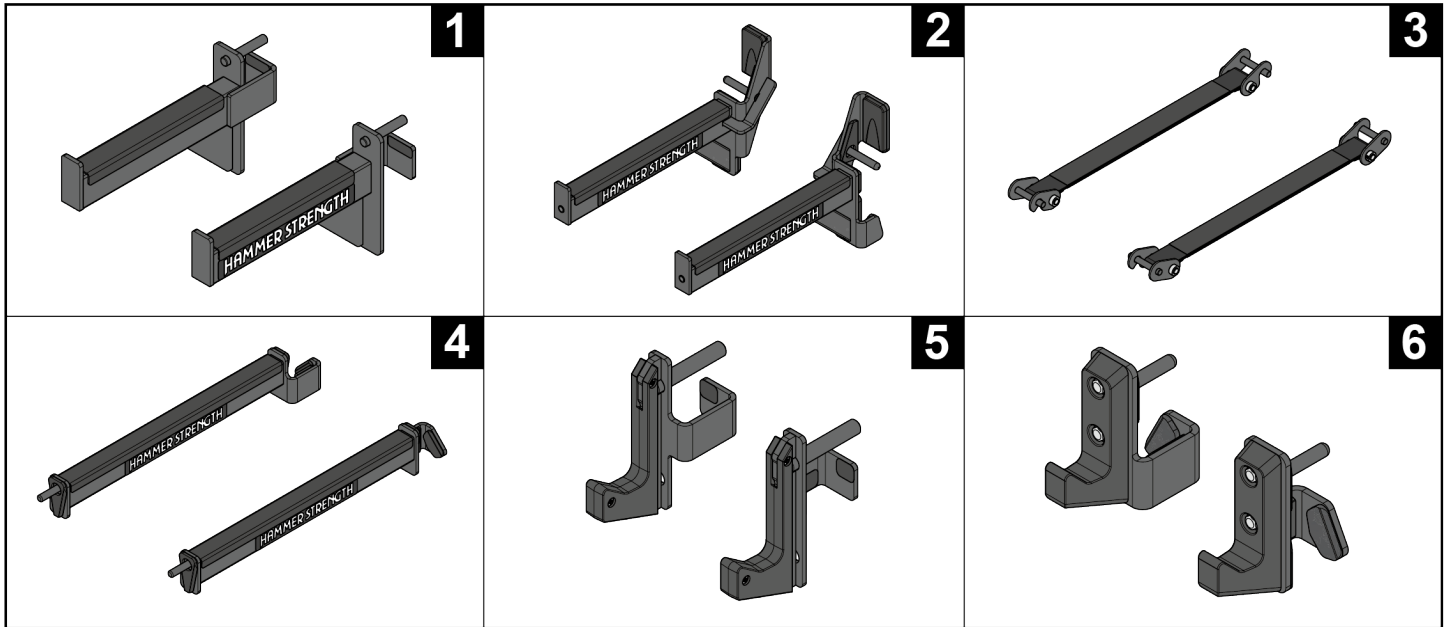

NOTE:

- Bar catches and supports are sold in pairs.
- All bar catches should always be used at or above 28" (71 cm) when performing squat exercises.
- If using HR Bar Catches on the outside of 6-Post Power Rack uprights, rack is required to be bolted to floor unless it has stability feet.

Item	Description
1	Standard HR Bar Catch
2	Premium HR Bar Catch
3	Flexible PR Bar Catch
4	Premium PR Bar Catch
5	Standard Bar Support
6	Premium Bar Support

Crossmembers

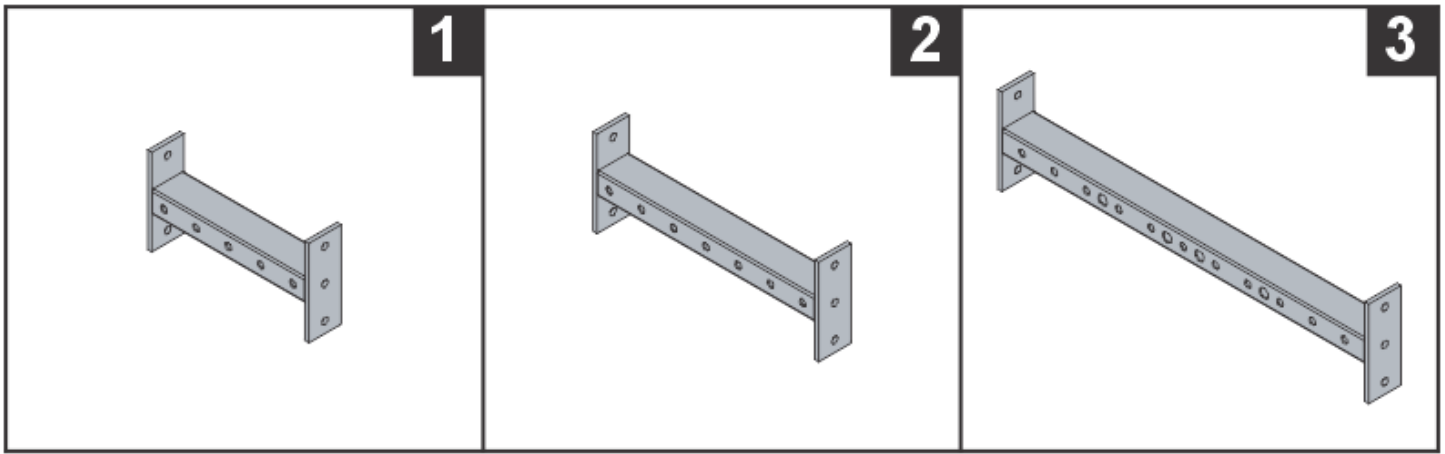

Item	Description	Usage
1	15inch/38cm	HDW-HR, HDW-PR, HDW-HHCR, HDW- PHCR, HDW-PPCR
2	21inch/53cm	
3	Power Rack	HDW-PR, HDW-PHCR, HDW-PPCR

Front Crossmembers

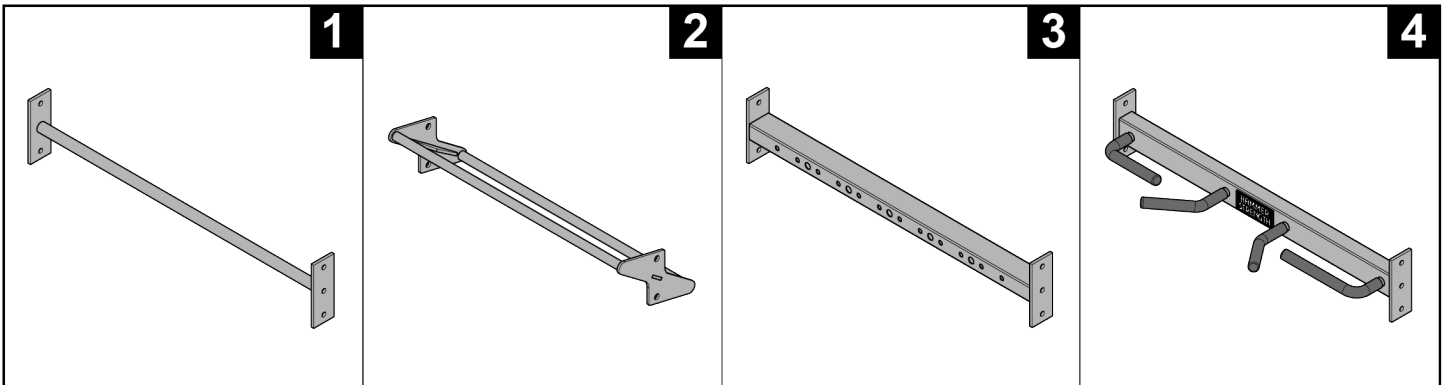

Item	Description
1	Monkey Bar
2	Off-Set Bar
3	2x3 Crossmember
4	2-Handle Bar

Rear Crossmembers

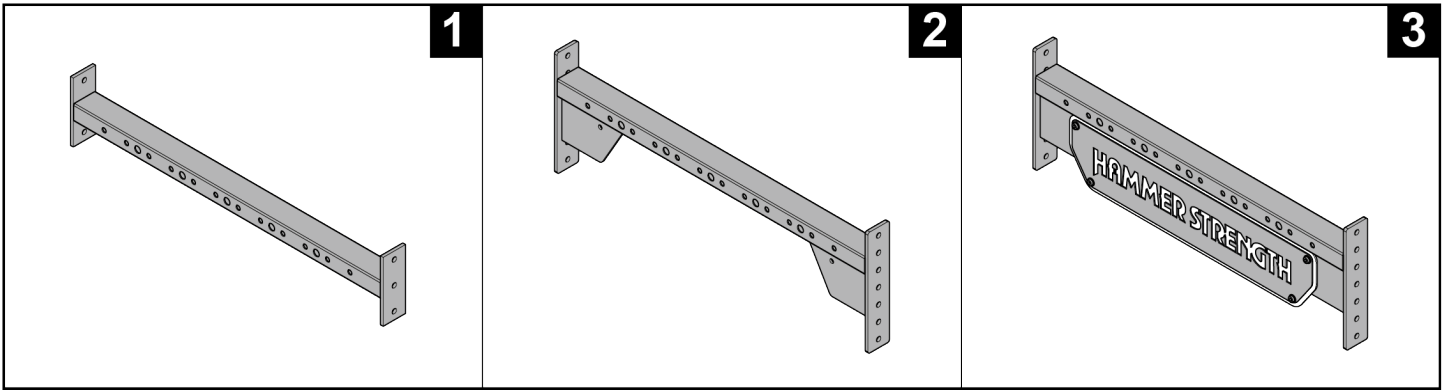

Item	Description
1	2x3 Crossmember
2	Super Duty
3	Hammer Strength Custom Sign

Weight Horns

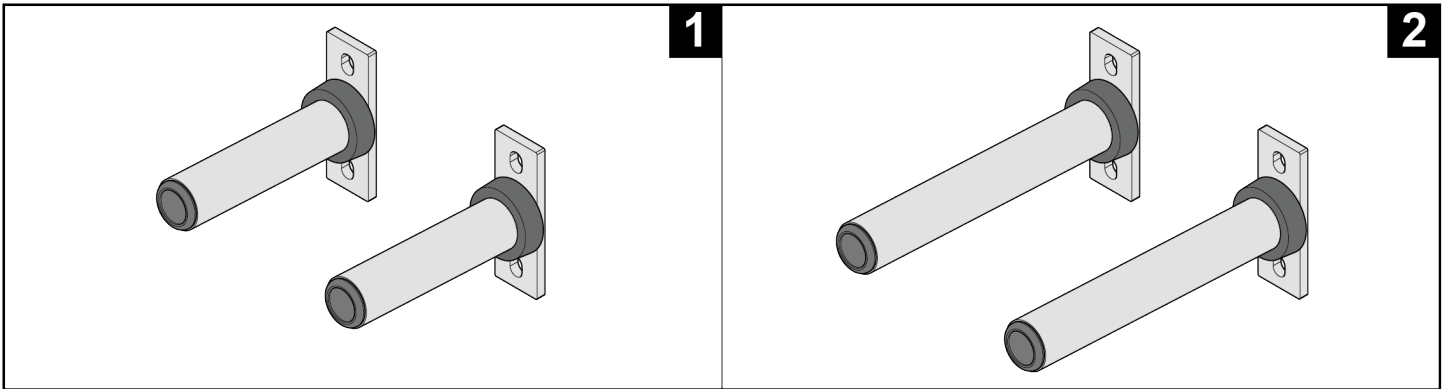

NOTE: Weight horns are sold in pairs.

Item	Description
1	7" Weight Horn
2	11" Weight Horn

Hardware Kit 1

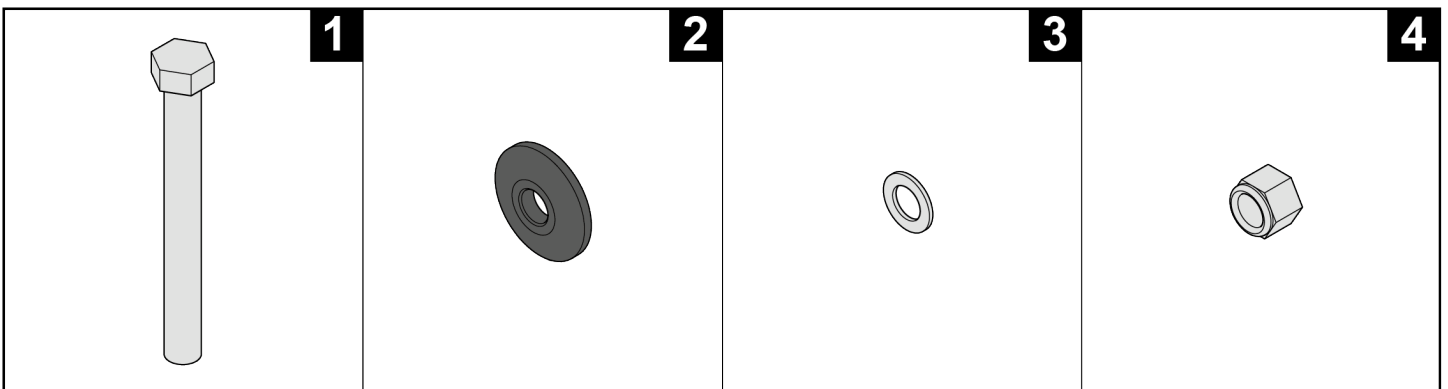

Item	Description	Qty.
1	Bolt, HHB .5 x 4.5	4

Item	Description	Qty.
2	Backing Washer	4
3	Lock Washer, 1/2"	4
4	Lock Nut, 1/2"	4

Hardware Kit 2

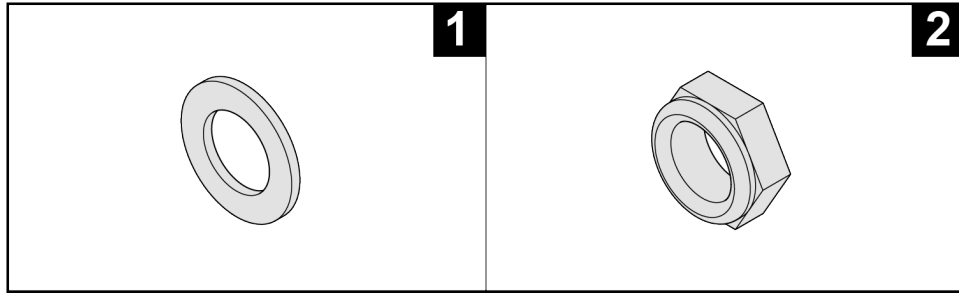

Item	Description	Qty.
1	Lock Washer, 1/2"	4
2	Lock Nut, 1/2" Thin	4

Hardware Kit 3

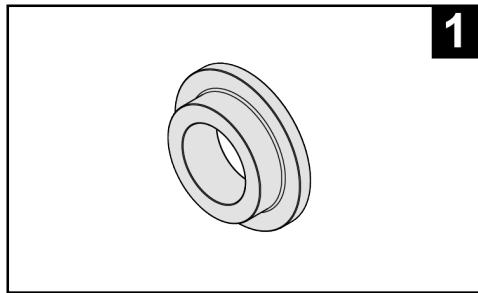

Item	Description	Qty.
1	Step Washer, 1/2"	4

Hardware Kit Configurations

Item	Hardware Kit 1	Hardware Kit 2	Hardware Kit 3
Front and Rear Crossmembers			
Monkey Bar	•		
Off-Set Bar	•		•
2x3 Crossmember	•		
2-Handle Bar	•		
Super Duty	•		
Hammer Strength Custom Sign	•		
Squat Stand			
Lower Crossmember	• Bolt, HHB .5 x 3 (x4) used with weight horns		
Stability Feet		•	
Weight Horns	•		
Half Rack			
Side Crossmember 15" (38 cm) or 21" (53 cm)	•		
Stability Feet		•	
Weight Horns	•		
Power Rack			
Side Crossmember 34.5" (88 cm)	•		
Side Crossmember 15" (38 cm) or 21" (53 cm)	•		
Stability Feet		•	
Weight Horns	•		
Combo Rack			
<i>Combo Racks consist of components from the Half Rack or Power Rack.</i>			

Tools Required

- 3/4" wrench (x2)
- 7 mm Allen wrench
- 17 mm wrench
- Torque wrench

Assembly Procedure

Two people will be required for this procedure.

TIP: Read and understand all instructions thoroughly before assembling this unit. Check all items carefully. If there is damage, see the Customer Service section of this manual for proper procedure to return, replace, or reorder parts.

Squat Stand (HDW-SQST)

Squat Stand not required to be bolted to floor due to Stability Feet.

Assemble Squat Stand

1. Lay components out on the ground.

NOTE: The Hammer Strength HS cut-out on the training uprights face out when the rack is assembled.

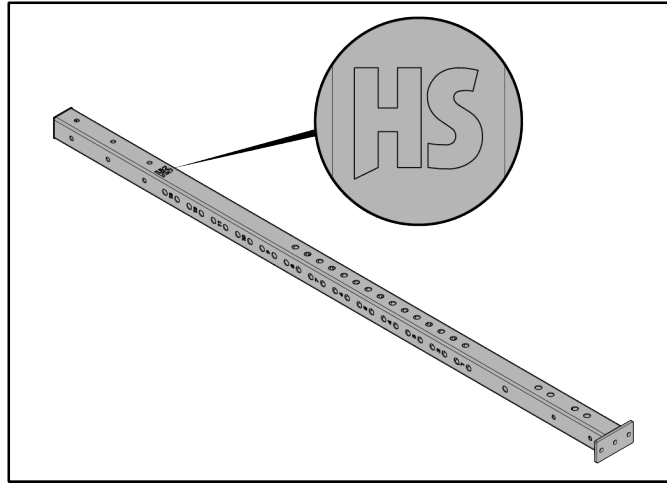

- Install bolts, washers, and thin lock nuts securing stability feet to training uprights using two 3/4" wrenches.

NOTE: The Hammer Strength HS cut-out on the training uprights face out when the rack is assembled.

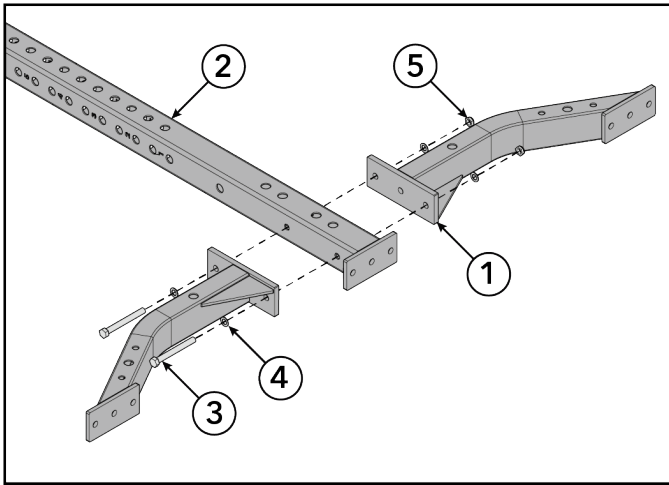

Item	Description	Qty.
1	Stability Feet	4
2	Training Upright	2
3	Bolt, HHB .5 x 4.5	4
4	Lock Washer, 1/2"	8
5	Lock Nut, 1/2" Thin	4



Hand tighten hardware.

NOTE: Stability feet are designed to lift the training uprights slightly off the floor. This is done to ensure solid contact to the floor at the furthest outside points.

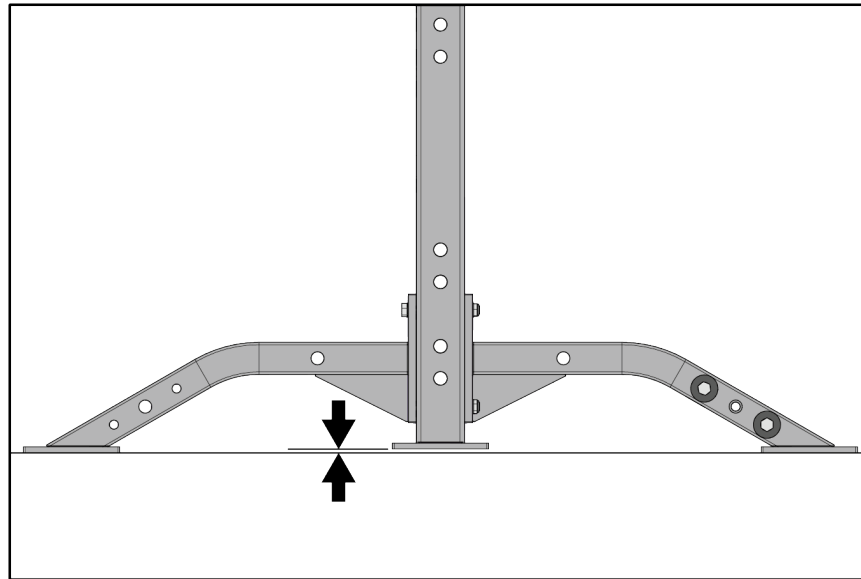

- Stand assembled components upright.
- Install bolts, backing washers, washers, and lock nuts securing lower crossmember to stability feet using two 3/4" wrenches.

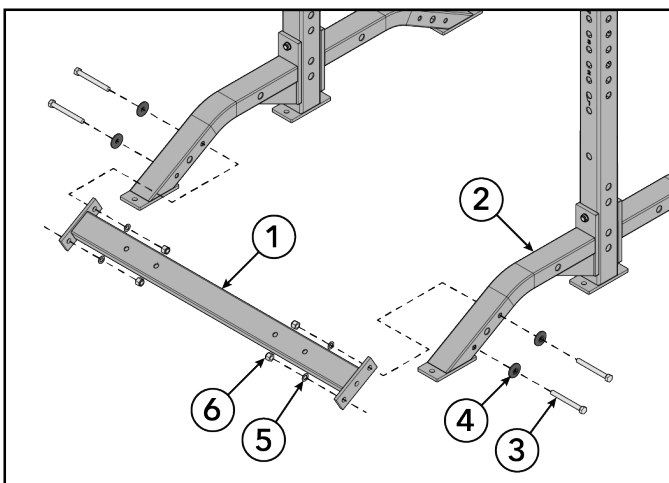

Item	Description	Qty.
1	Lower Crossmember	1
2	Stability Feet	2
3	Bolt, HHB .5 x 4.5	4
4	Backing Washer	4
5	Lock Washer, 1/2"	4
6	Lock Nut, 1/2"	4



Hand tighten hardware.

5. Install bolts, backing washers, washers, and lock nuts securing upper crossmember to training uprights using two 3/4" wrenches.

NOTE: Monkey bar upper crossmember shown for example.

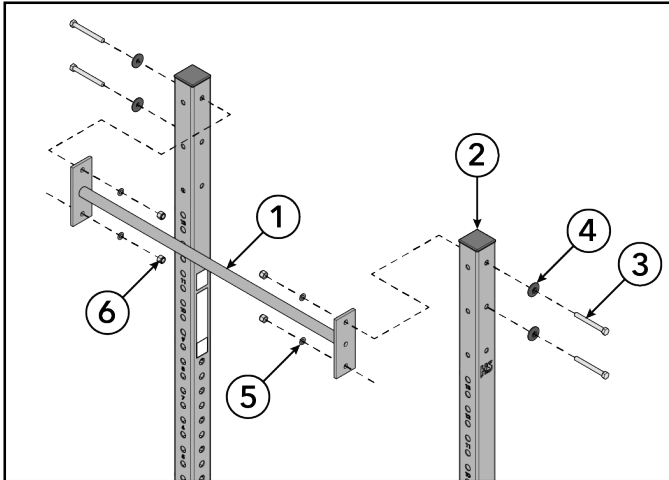

Item	Description	Qty.
1	Upper Crossmember	1
2	Training Upright	2
3	Bolt, HHB .5 x 4.5	4
4	Backing Washer	4
5	Lock Washer, 1/2"	4
6	Lock Nut, 1/2"	4



Hand tighten hardware.

6. NOTE: OPTIONAL

Install bolts, washers, backing washers, and lock nuts securing weight horns to lower crossmember using two 3/4" wrenches.

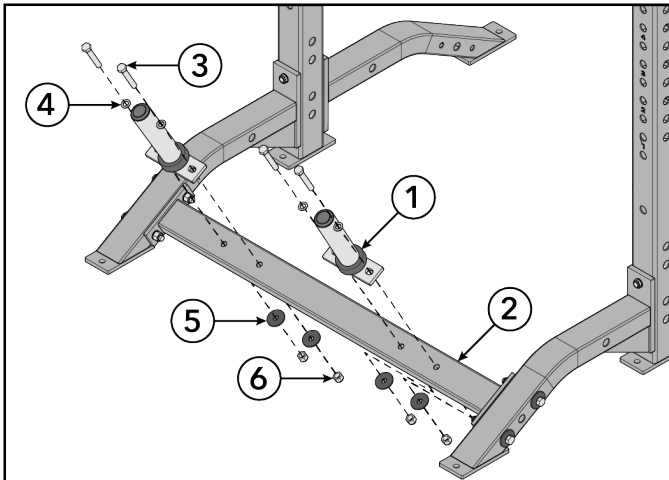

Item	Description	Qty.
1	Weight Horn	2
2	Lower Crossmember	1
3	Bolt, HHB .5 x 3	4
4	Lock Washer, 1/2"	4
5	Backing Washer	4
6	Lock Nut, 1/2"	4



Tighten hardware to 20-25 ft-lb (27-34 Nm).

7. Tighten all loose hardware to 20-25 ft-lb (27-34 Nm) in the following order.

- a. Lower stability feet bolts to training uprights.
- b. Upper stability feet bolts to training uprights.
- c. Lower crossmember to stability feet.
- d. Upper crossmember to training uprights.

Component List

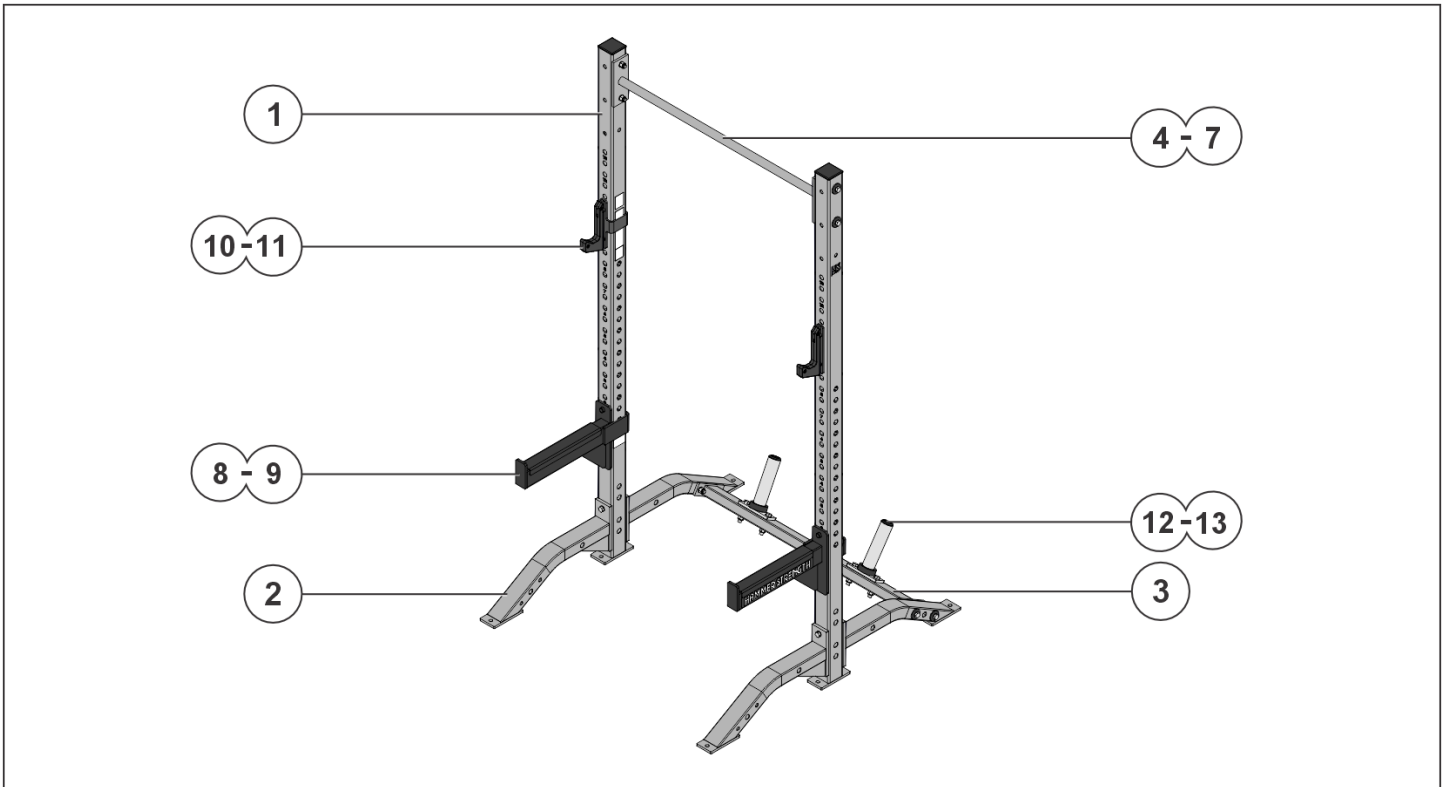

Item	Description	Qty.
1	Training Upright 86" (218 cm), 91" (231 cm) or 96" (244 cm)	2
2	Stability Feet	4
3	Lower Crossmember	1
Front Crossmembers		
4	Monkey Bar	1
5	Off-Set Bar	
6	2x3 Crossmember	
7	2-Handle Bar	
Bar Catches and Supports		
8	Standard HR Bar Catch	2
9	Premium HR Bar Catch	
10	Standard Bar Support	2
11	Premium Bar Support	
Optional: Weight Horns		
12	7" Weight Horn	1 pair
13	11" Weight Horn	

Half Rack (HDW-HR)

Half Rack not required to be bolted to floor due to Stability Feet.

Assemble Half Rack

1. Lay components out on the ground.
 - The Hammer Strength HS cut-out on the training uprights face out when the rack is assembled.
 - Review the Label Locations topic to make sure that the serial number and warning labels etc. are in the appropriate location for each upright when assembling.

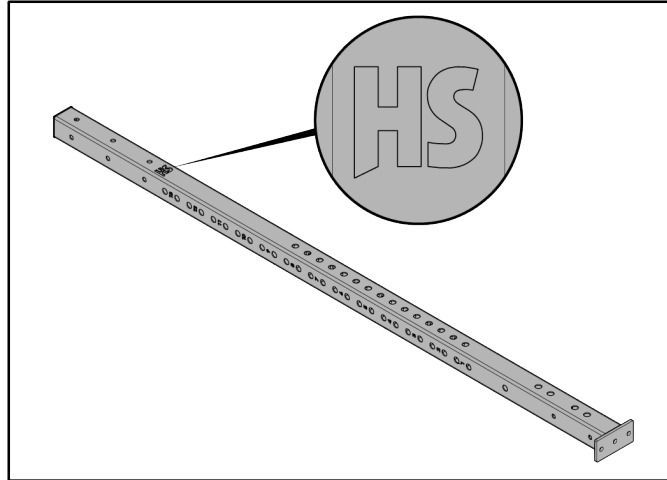

2. Install bolts, backing washers, washers, and lock nuts securing side crossmembers to tops of training uprights and storage uprights using two 3/4" wrenches.

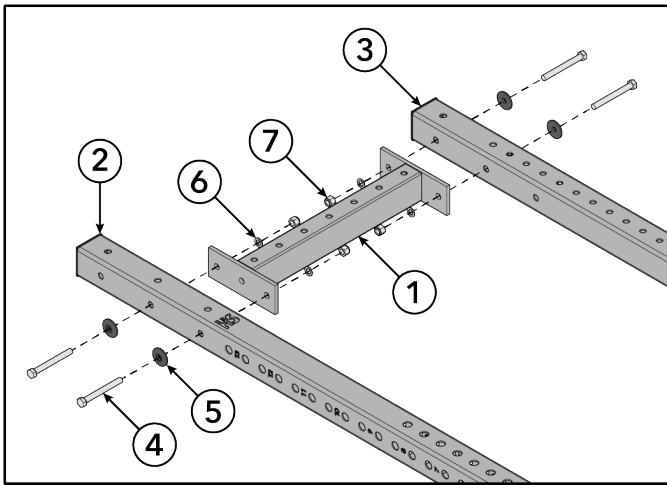

Item	Description	Qty.
1	Side Crossmember	2
2	Training Upright	2
3	Storage Upright	2
4	Bolt, HHB .5 x 4.5	8
5	Backing Washer	8
6	Lock Washer, 1/2"	8
7	Lock Nut, 1/2"	8



Hand tighten hardware.

3. Install bolts, backing washers, washers, and lock nuts securing side crossmembers to bottoms of storage uprights using two 3/4" wrenches.

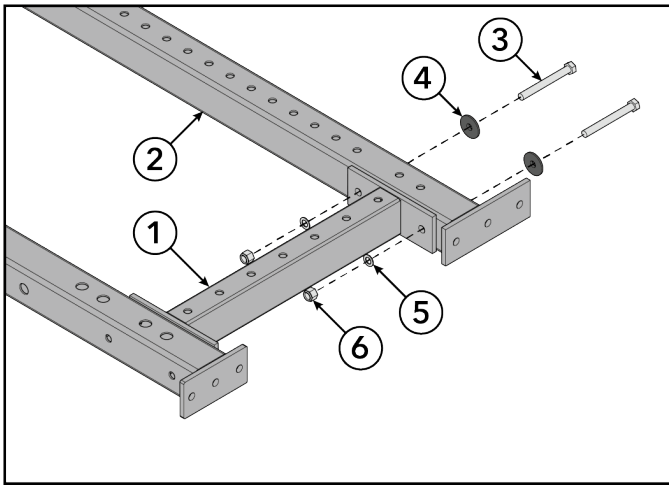

Item	Description	Qty.
1	Side Crossmember	2
2	Storage Upright	2
3	Bolt, HHB .5 x 4.5	4
4	Backing Washer	4
5	Lock Washer, 1/2"	4
6	Lock Nut, 1/2"	4



Hand tighten hardware.

4. Install bolts, washers, and thin lock nuts securing stability feet to training uprights using two 3/4" wrenches.

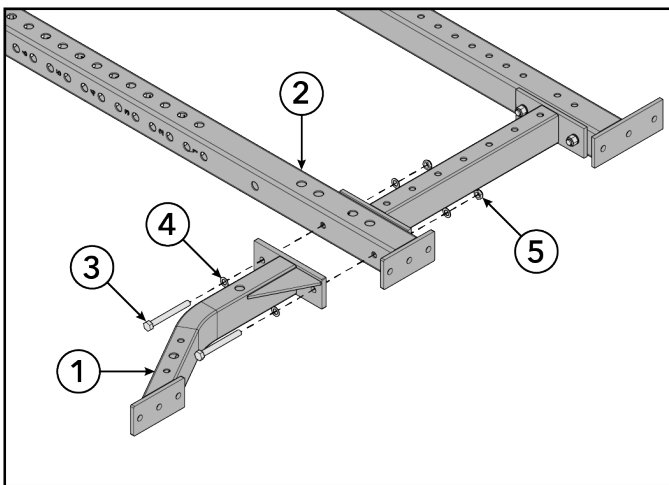

Item	Description	Qty.
1	Stability Feet	2
2	Training Upright	2
3	Bolt, HHB .5 x 4.5	4
4	Lock Washer, 1/2"	8
5	Lock Nut, 1/2" Thin	4



Hand tighten hardware.

NOTE: Stability feet are designed to lift the training uprights slightly off the floor. This is done to ensure solid contact to the floor at the furthest outside points.

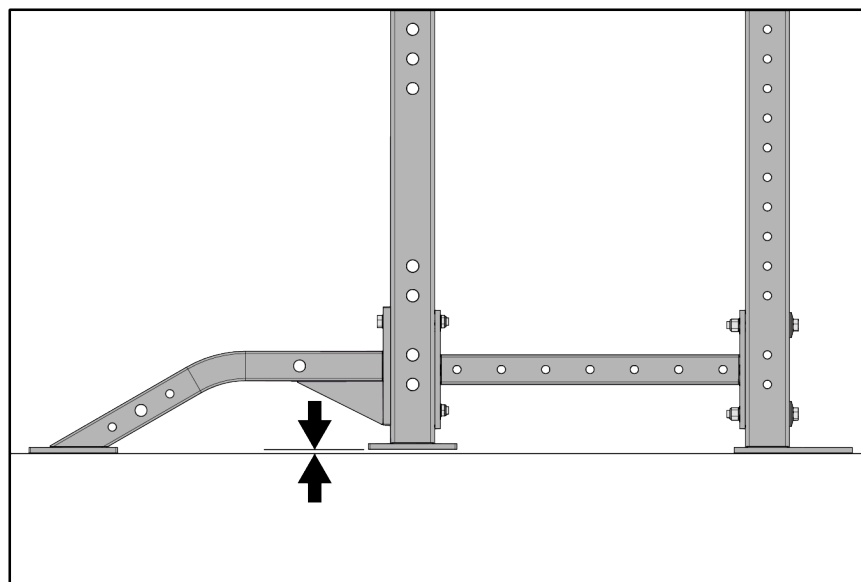

5. Stand assembled components upright.

6. Install bolts, backing washers, washers, and lock nuts securing rear crossmember to storage uprights using two 3/4" wrenches.

NOTE: 2x3 crossmember shown for example.

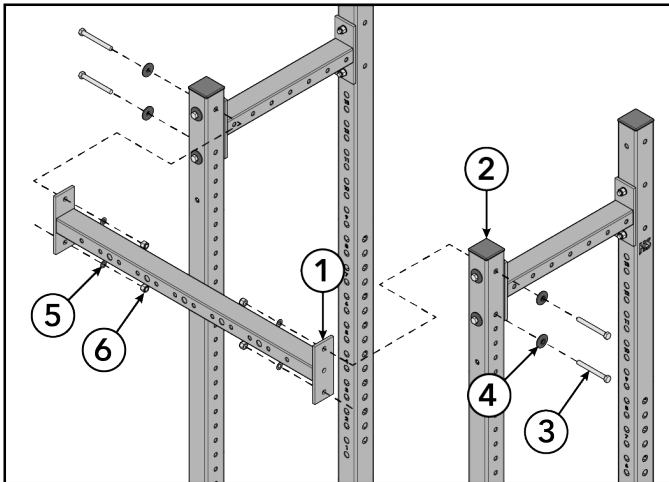

Item	Description	Qty.
1	Rear Crossmember	1
2	Storage Upright	2
3	Bolt, HHB .5 x 4.5	4
4	Backing Washer	4
5	Lock Washer, 1/2"	4
6	Lock Nut, 1/2"	4



Hand tighten hardware.

7. Install bolts, backing washers, washers, and lock nuts securing front crossmember to training uprights using two 3/4" wrenches.

NOTE: Monkey bar front crossmember shown for example.

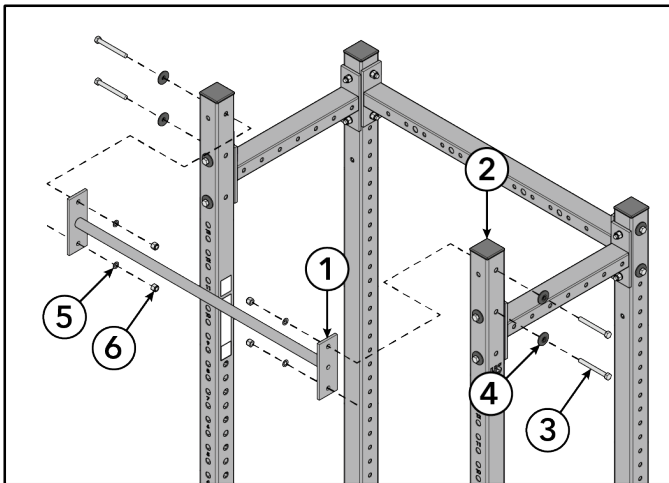

Item	Description	Qty.
1	Front Crossmember	1
2	Training Upright	2
3	Bolt, HHB .5 x 4.5	4
4	Backing Washer	4
5	Lock Washer, 1/2"	4
6	Lock Nut, 1/2"	4

8. Tighten all loose hardware to 20-25 ft-lb (27-34 Nm) in the following order.

- a. Lower stability feet bolts to training uprights.
- b. Upper stability feet bolts to training uprights.
- c. Lower crossmembers to storage uprights.
- d. Upper crossmembers to training and storage uprights.
- e. Rear crossmember to storage uprights.
- f. Front crossmember to training uprights.

Component List

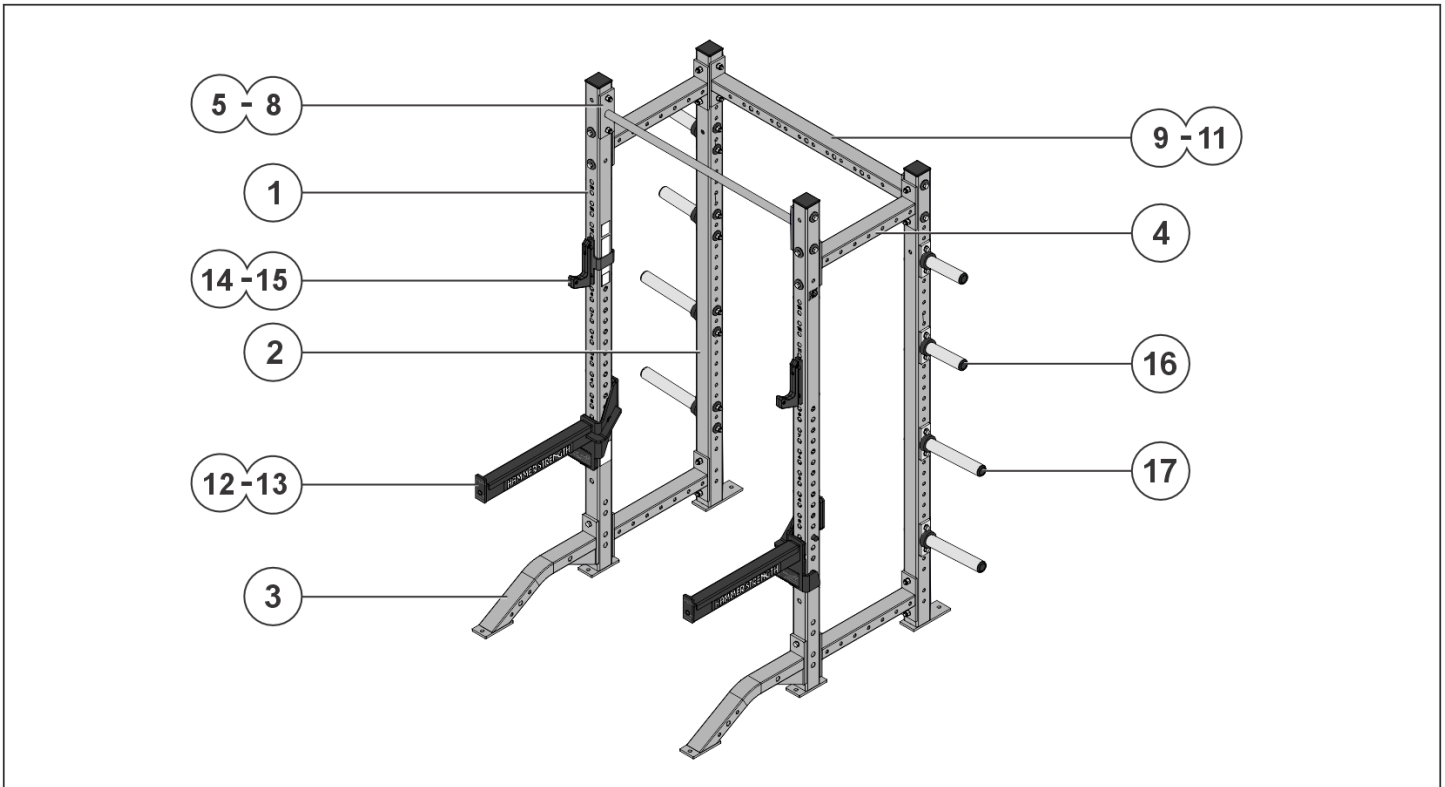

Item	Description	Qty.
1	Training Upright 86" (218 cm), 91" (231 cm) or 96" (244 cm)	2
2	Storage Upright 86" (218 cm) or 91" (231 cm)	2
3	Stability Feet	2
4	Storage Depth 15" (38 cm) or 21" (53 cm)	4
Front Crossmembers		
5	Monkey Bar	1
6	Off-Set Bar	
7	2x3 Crossmember	
8	2-Handle Bar	
Rear Crossmembers		
9	2x3 Crossmember	1
10	Super Duty	
11	Hammer Strength Custom Sign	
Bar Catches		
12	Standard HR Bar Catch	1
13	Premium HR Bar Catch	
Bar Supports		

Item	Description	Qty.
14	Standard Bar Support	1
15	Premium Bar Support	
Weight Horns		
16	7" Weight Horn	5 pair
17	11" Weight Horn	

Power Rack (HDW-PR)

Power Rack required to be bolted to floor unless ordered with Weight Plate Storage Uprights option.

NOTE: If using HR Bar Catches on the outside of 6-Post Power Rack uprights, rack is required to be bolted to floor unless it has stability feet.

4-Post Power Rack

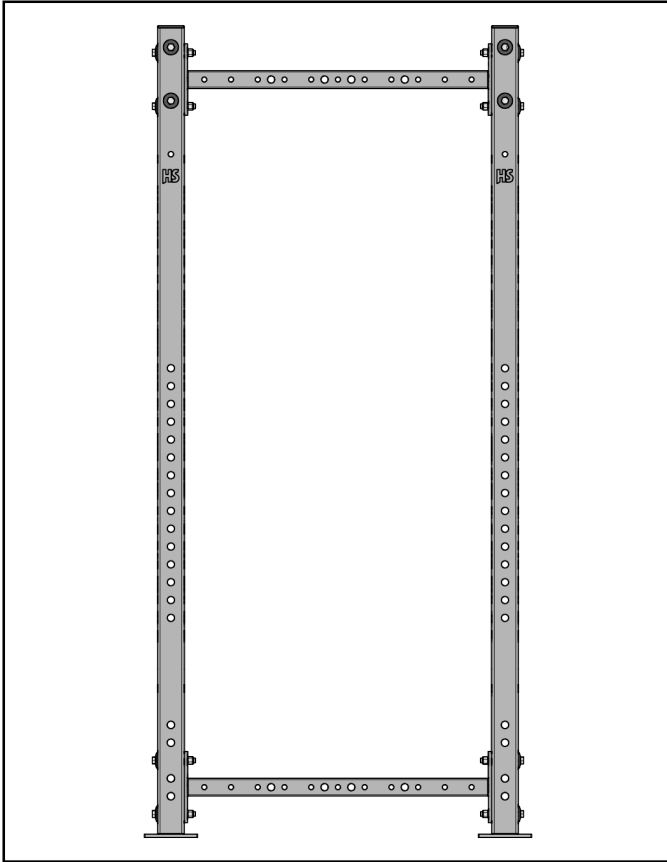

6-Post Power Rack

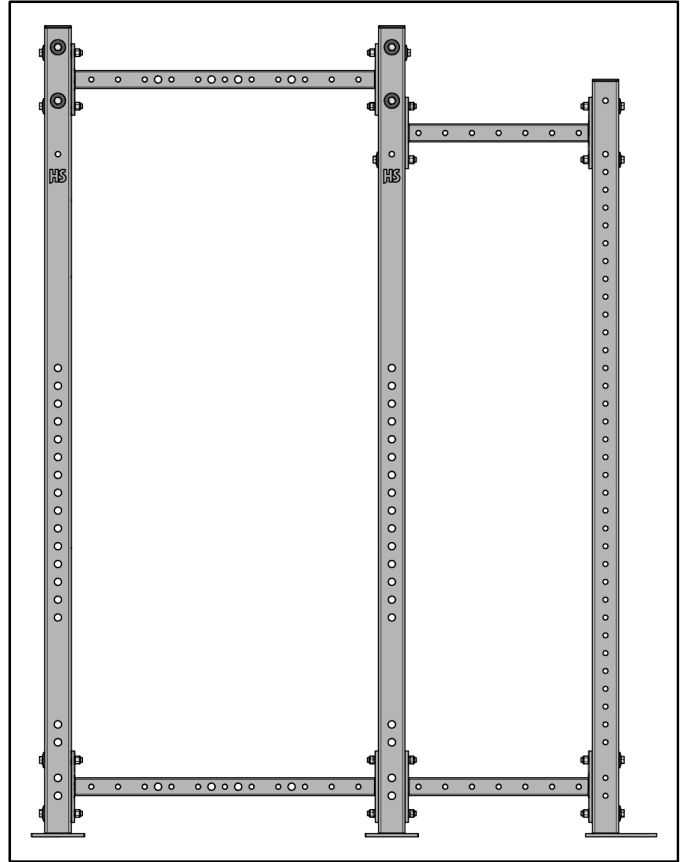

Assemble Power Rack

1. Lay components out on the ground.

- The Hammer Strength HS cut-out on the training uprights face out when the rack is assembled.
- Review the Label Locations topic to make sure that the serial number and warning labels etc. are in the appropriate location for each upright when assembling.

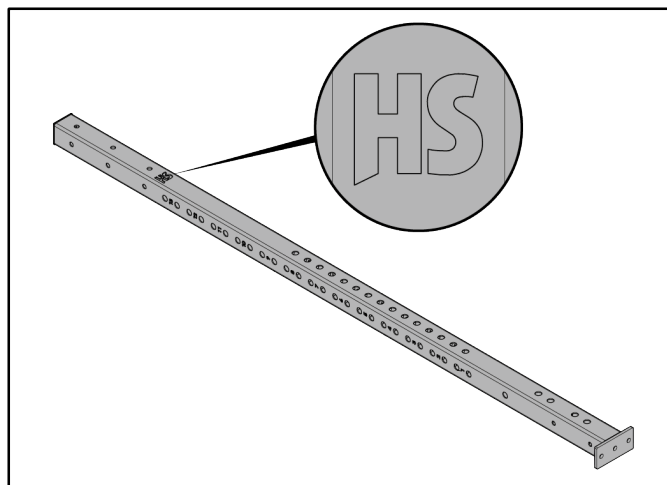

- Install bolts, backing washers, washers, and lock nuts securing side crossmembers to tops of training uprights using two 3/4" wrenches.

NOTE: The Hammer Strength HS cut-out on the training uprights face out when the rack is assembled.

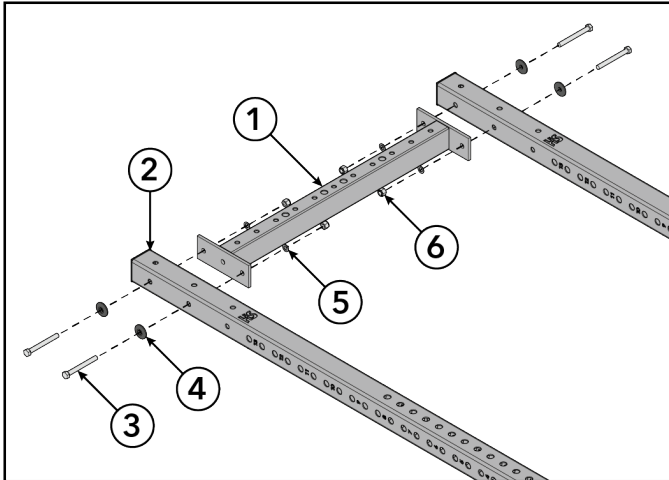

Item	Description	Qty.
1	Side Crossmember	2
2	Training Upright	4
3	Bolt, HHB .5 x 4.5	8
4	Backing Washer	8
5	Lock Washer, 1/2"	8
6	Lock Nut, 1/2"	8



Hand tighten hardware.

- Install bolts, backing washers, washers, and lock nuts securing side crossmembers to bottoms of training uprights using two 3/4" wrenches.

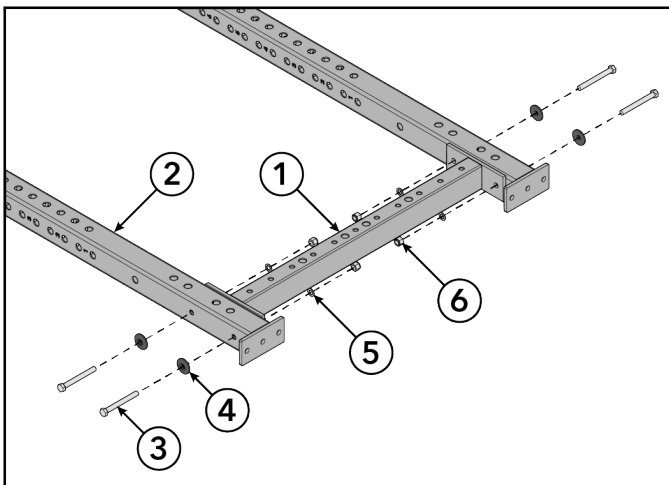

Item	Description	Qty.
1	Side Crossmember	2
2	Storage Upright	4
3	Bolt, HHB .5 x 4.5	8
4	Backing Washer	8
5	Lock Washer, 1/2"	8
6	Lock Nut, 1/2"	8



Hand tighten hardware.

4. NOTE: OPTIONAL

Install bolts, washers, and thin lock nuts securing stability feet to training uprights using two 3/4" wrenches.

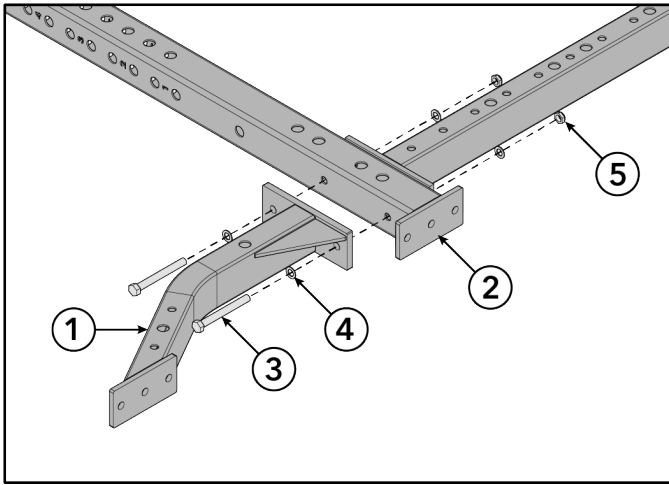

Item	Description	Qty.
1	Stability Feet	2
2	Training Upright	2
3	Bolt, HHB .5 x 4.5	4
4	Lock Washer, 1/2"	8
5	Lock Nut, 1/2" Thin	4



Hand tighten hardware.

NOTE: Stability feet are designed to lift the training uprights slightly off the floor. This is done to ensure solid contact to the floor at the furthest outside points.

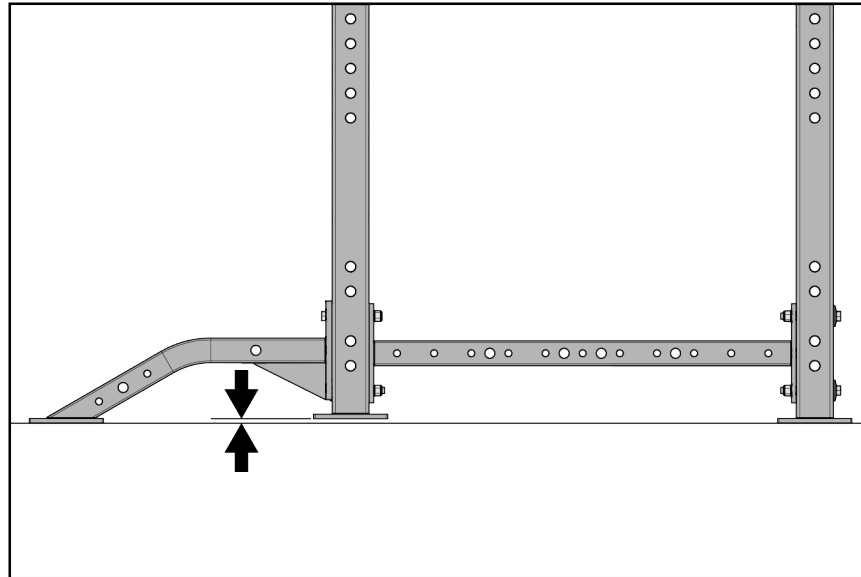

- Stand assembled components upright.
- Install bolts, backing washers, washers, and lock nuts securing rear crossmember to training uprights using two 3/4" wrenches.

NOTE: 2x3 crossmember shown for example.

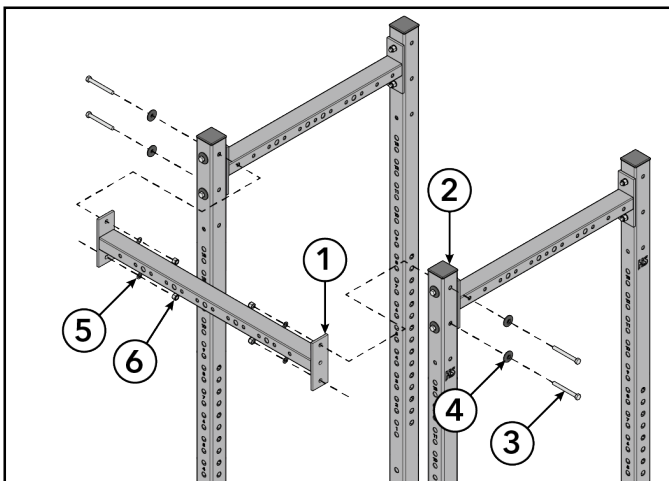

Item	Description	Qty.
1	Rear Crossmember	1
2	Training Upright	2
3	Bolt, HHB .5 x 4.5	4
4	Backing Washer	4
5	Lock Washer, 1/2"	4
6	Lock Nut, 1/2"	4



Hand tighten hardware.

7. Install bolts, backing washers, washers, and lock nuts securing front crossmember to training uprights using two 3/4" wrenches.

NOTE: Monkey bar front crossmember shown for example.

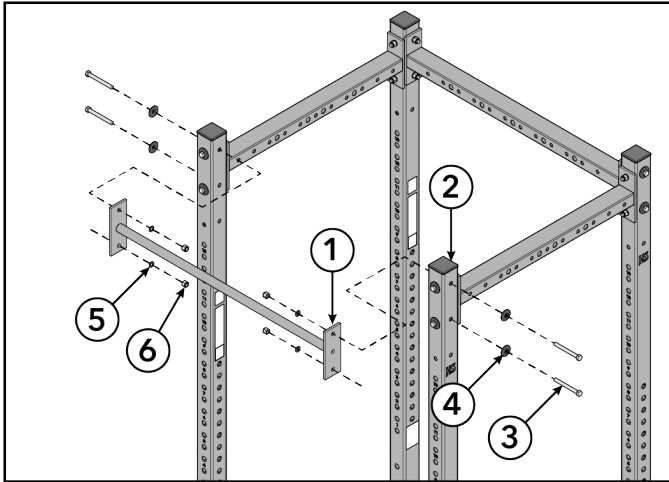

Item	Description	Qty.
1	Front Crossmember	1
2	Training Upright	2
3	Bolt, HHB .5 x 4.5	4
4	Backing Washer	4
5	Lock Washer, 1/2"	4
6	Lock Nut, 1/2"	4



Hand tighten hardware.

8. Tighten all loose hardware to 20-25 ft-lb (27-34 Nm) in the following order.
 - a. **Optional:** Lower stability feet bolts to training uprights.
 - b. **Optional:** Upper stability feet bolts to training uprights.
 - c. Lower side crossmembers to training uprights.
 - d. Upper side crossmembers to training uprights.
 - e. Rear crossmember to training uprights.
 - f. Front crossmember to training uprights.

Install Additional Storage Uprights

The following procedure shows how to install the additional storage uprights for the 6-Post Power Rack.

1. Remove bolts, backing washers, washers, and lock nuts securing side crossmembers to bottoms of storage uprights using two 3/4" wrenches.

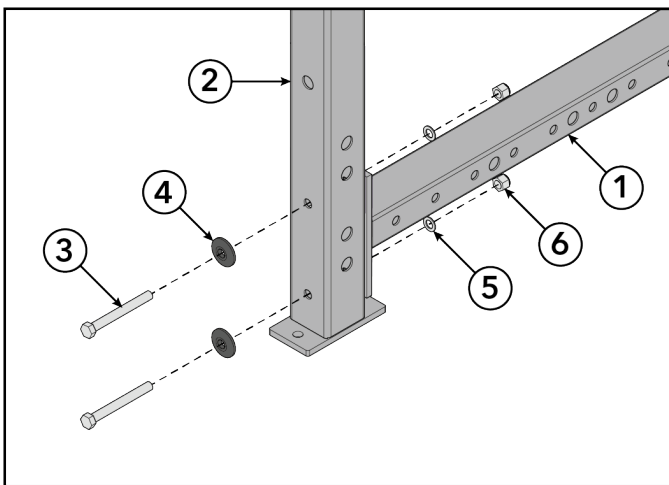

Item	Description	Qty.
1	Side Crossmember	2
2	Storage Upright	2
3	Bolt, HHB .5 x 4.5	4
4	Backing Washer	4
5	Lock Washer, 1/2"	4
6	Lock Nut, 1/2"	4

- Remove lower bolts, backing washers, washers, and lock nuts securing side crossmembers to tops of storage uprights using two 3/4" wrenches.

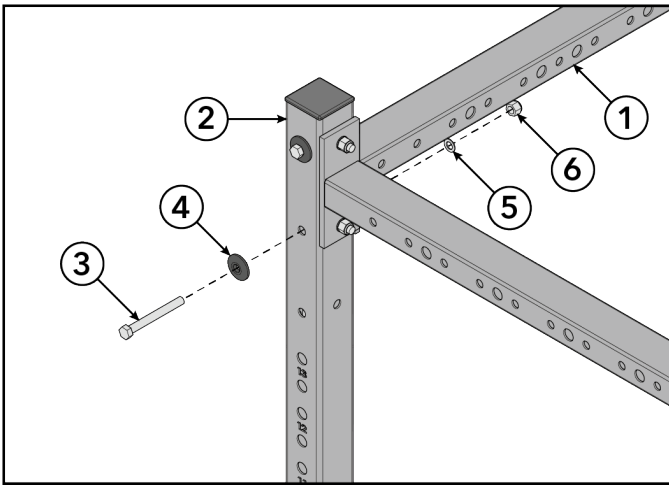

Item	Description	Qty.
1	Side Crossmember	2
2	Storage Upright	2
3	Bolt, HHB .5 x 4.5	2
4	Backing Washer	2
5	Lock Washer, 1/2"	2
6	Lock Nut, 1/2"	2

- Lay additional components for 6-Post Power Rack out on the ground.
- Install bolts, backing washers, washers, and lock nuts securing side crossmembers to tops of storage uprights using two 3/4" wrenches.

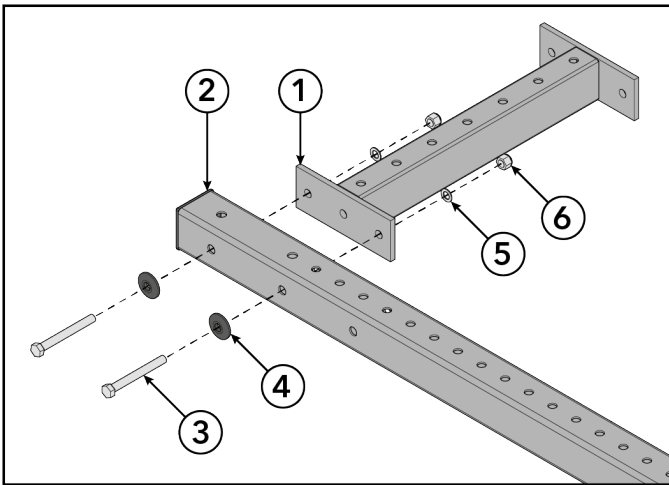

Item	Description	Qty.
1	Side Crossmember 15" (38 cm) or 21" (53 cm)	2
2	Storage Upright	2
3	Bolt, HHB .5 x 4.5	4
4	Backing Washer	4
5	Lock Washer, 1/2"	4
6	Lock Nut, 1/2"	4



Hand tighten hardware.

- Install bolts, backing washers, washers, and lock nuts securing side crossmembers to bottoms of storage uprights using two 3/4" wrenches.

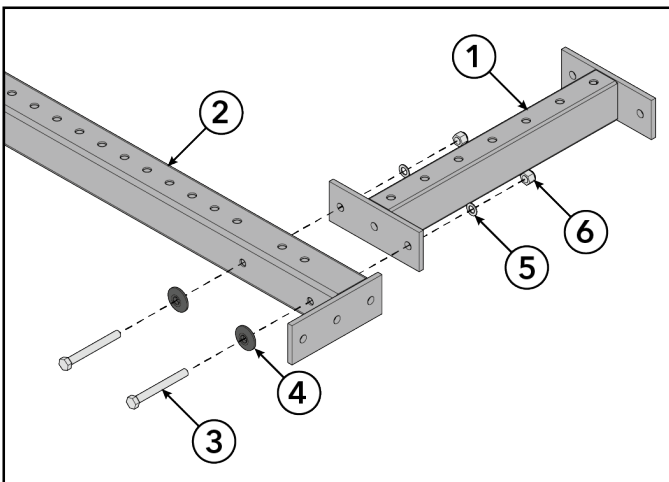

Item	Description	Qty.
1	Side Crossmember	2
2	Storage Upright	2
3	Bolt, HHB .5 x 4.5	4
4	Backing Washer	4
5	Lock Washer, 1/2"	4
6	Lock Nut, 1/2"	4



Hand tighten hardware.

- Stand assembled components upright.

7. Install bolts, washers, and lock nuts securing side crossmembers to bottoms of 4-Post Power Rack storage uprights using two 3/4" wrenches.

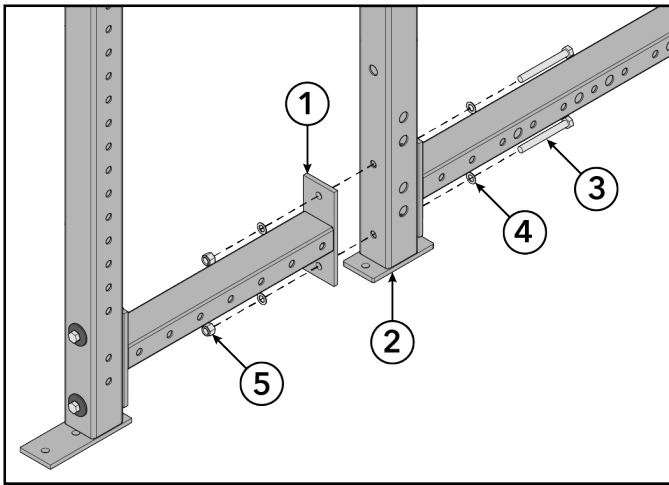

Item	Description	Qty.
1	Side Crossmember	2
2	Storage Upright	2
3	Bolt, HHB .5 x 4.5	4
4	Lock Washer, 1/2"	8
5	Lock Nut, 1/2"	4



Hand tighten hardware.

8. Install bolts, backing washers, washers, and lock nuts securing side crossmembers to bottoms of 4-Post Power Rack storage uprights using two 3/4" wrenches.

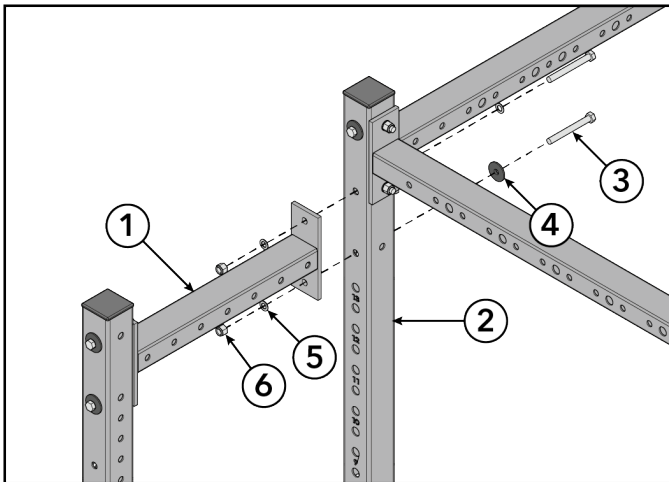

Item	Description	Qty.
1	Side Crossmember	2
2	Storage Upright	2
3	Bolt, HHB .5 x 4.5	4
4	Backing Washer	2
5	Lock Washer, 1/2"	6
6	Lock Nut, 1/2"	4



Hand tighten hardware.

9. Tighten all loose hardware to 20-25 ft-lb (27-34 Nm).

Component List

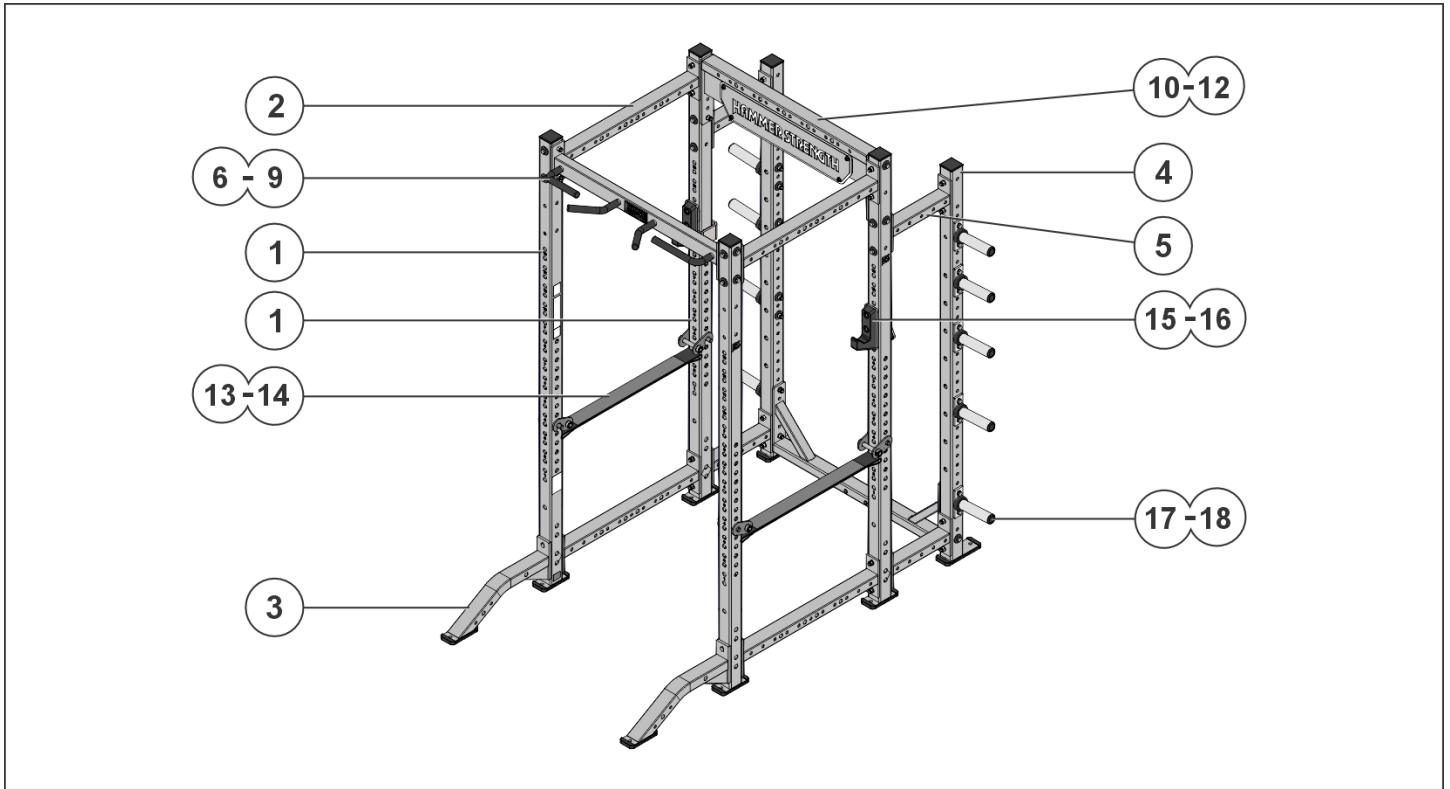

Item	Description	Qty.
4-Post Power Rack		
1	Training Upright 86" (218 cm), 91" (231 cm) or 96" (244 cm)	2
2	Side Crossmember 34.5" (88 cm)	4
3	Optional: Stability Feet	2
6-Post Power Rack		
1	Training Upright 86" (218 cm), 91" (231 cm) or 96" (244 cm)	4
2	Training Depth 34.5" (88 cm)	4
3	Optional: Stability Feet	2
4	Storage Upright 86" (218 cm) or 91" (231 cm)	2
5	Storage Depth 15" (38 cm) or 21" (53 cm)	4
Front Crossmembers		

Item	Description	Qty.
6	Monkey Bar	1
7	Off-Set Bar	
8	2x3 Crossmember	
9	2-Handle Bar	
Rear Crossmembers		
10	2x3 Crossmember	1
11	Super Duty	
12	Hammer Strength Custom Sign	
Bar Catches		
13	Standard HR Bar Catch	1
14	Premium HR Bar Catch	
Bar Supports		
15	Standard Bar Support	1
16	Premium Bar Support	
Weight Horns		
17	7" Weight Horn	5 pair
18	11" Weight Horn	

Combo Rack (HDW-HHCR, HDW-PHCR, HDW-PPCR)

Half / Half Combo Rack required to be bolted to floor unless ordered with Stability Feet option.

Half / Half Combo Rack (HDW-HHCR)

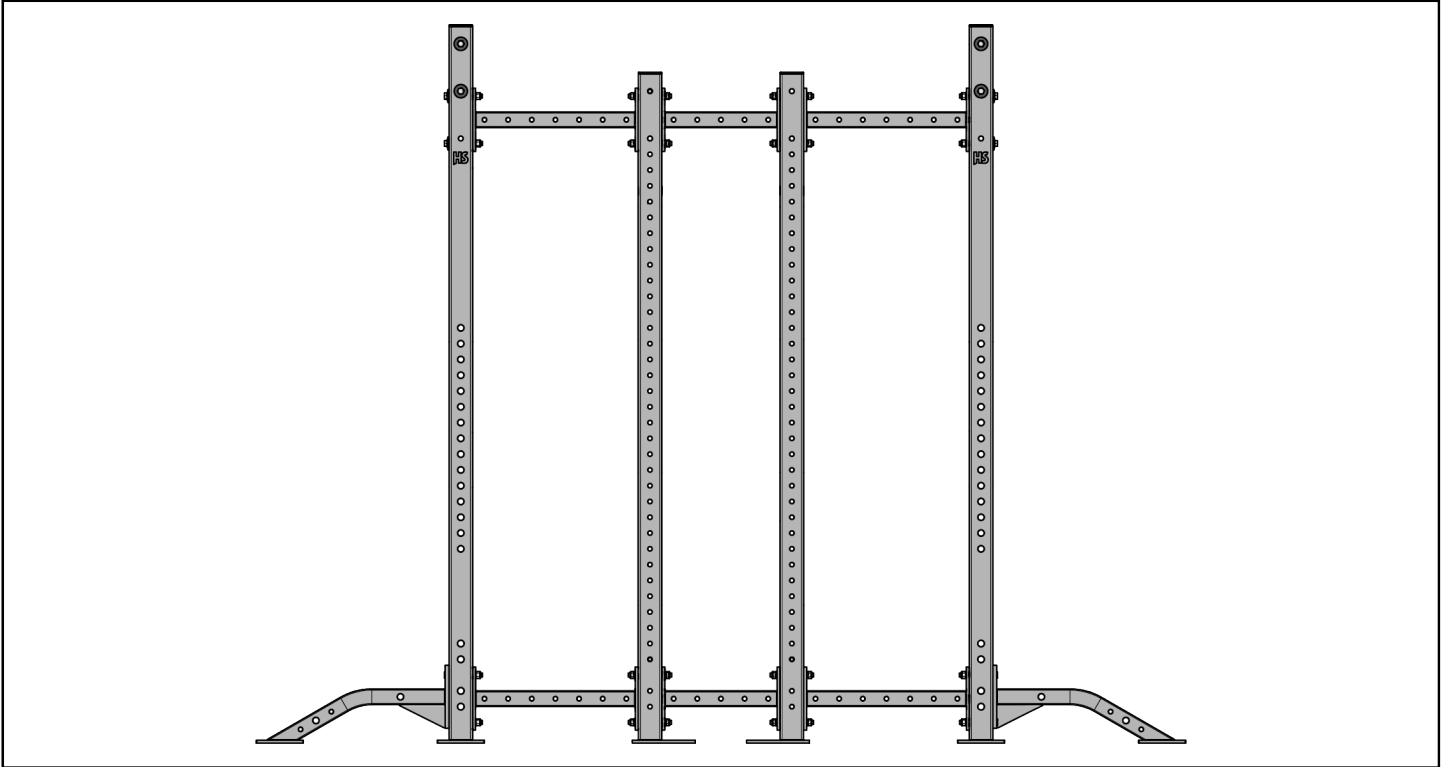

Power / Half Combo Rack required to be bolted to floor unless ordered with Stability Feet option.

Power / Half Combo Rack (HDW-PHCR)

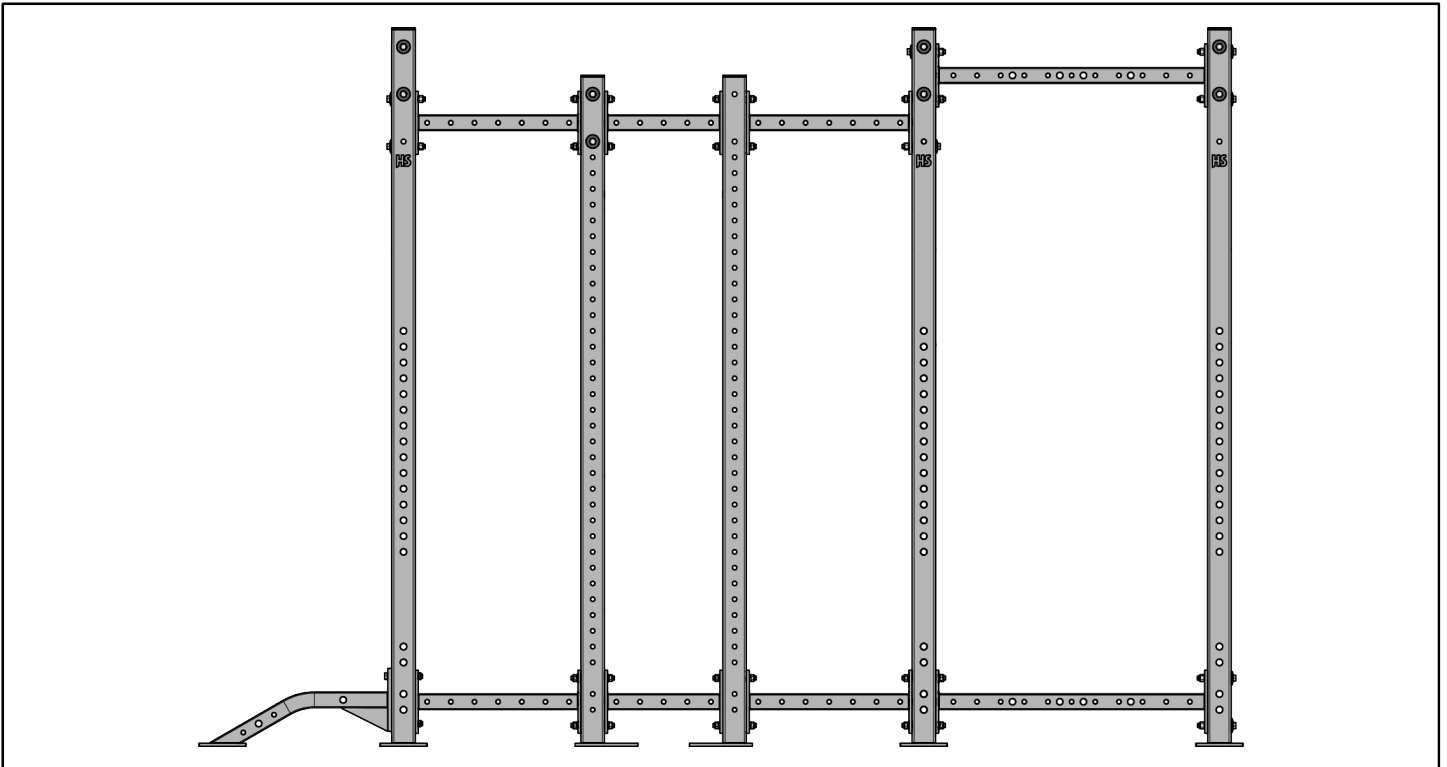

Power / Power Combo Rack is not required to be bolted to floor.

Power / Power Combo Rack (HDW-PPCR)

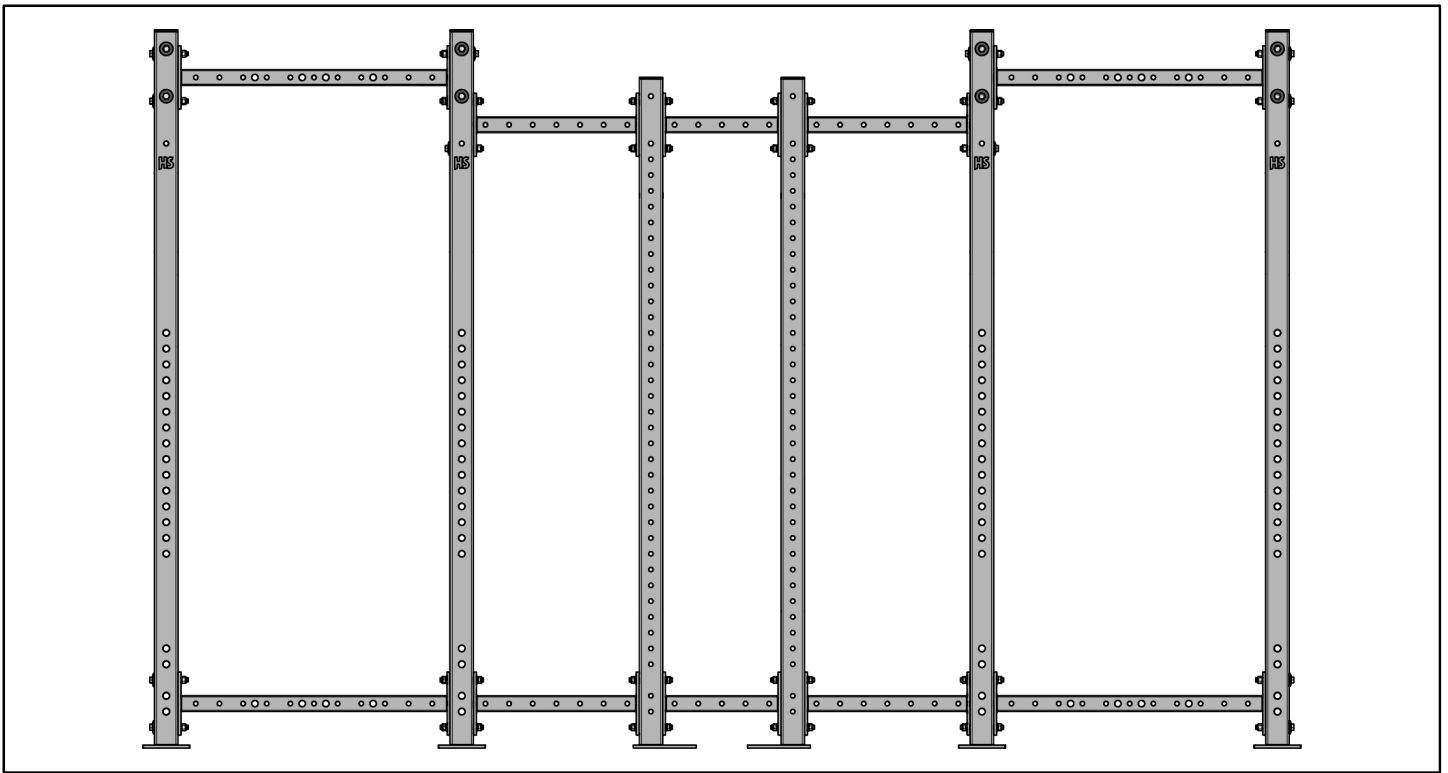

Assemble Combo Rack

This procedure shows how to assemble the Combo Racks. The Half / Half Combo Rack with Long Double Storage is shown for example, some steps may not apply to units with Single Storage. Other Combo Racks can be assembled using the same procedure.

1. Lay components out on the ground.

- The Hammer Strength HS cut-out on the training uprights face out when the rack is assembled.
- Review the Label Locations topic to make sure that the serial number and warning labels etc. are in the appropriate location for each upright when assembling.

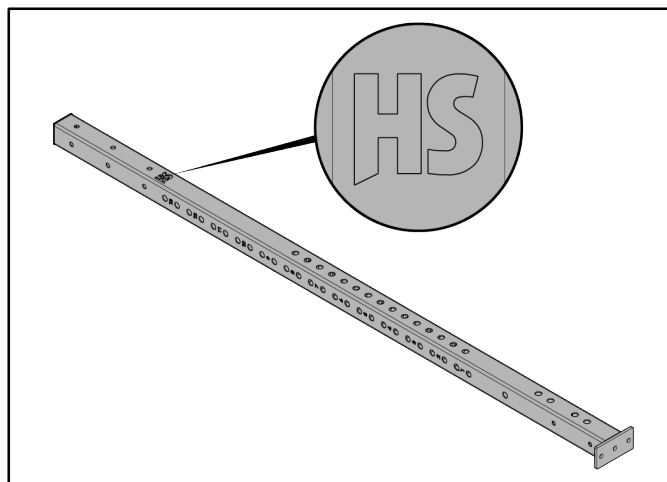

2. Install bolts, backing washers, washers, and lock nuts securing side crossmembers to tops of training uprights and storage uprights using two 3/4" wrenches.

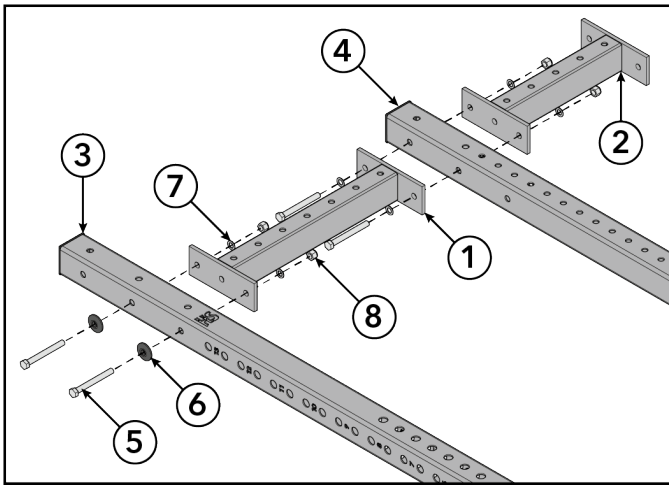

Item	Description	Qty.
1	Side Crossmember 21" (53 cm)	2
2	Side Crossmember 15" (38 cm)	2
3	Training Upright	2
4	Storage Upright	2
5	Bolt, HHB .5 x 4.5	8
6	Backing Washer	8
7	Lock Washer, 1/2"	8
8	Lock Nut, 1/2"	8



Hand tighten hardware.

3. Install bolts, washers, and lock nuts securing side crossmembers to bottoms of storage uprights using two 3/4" wrenches.

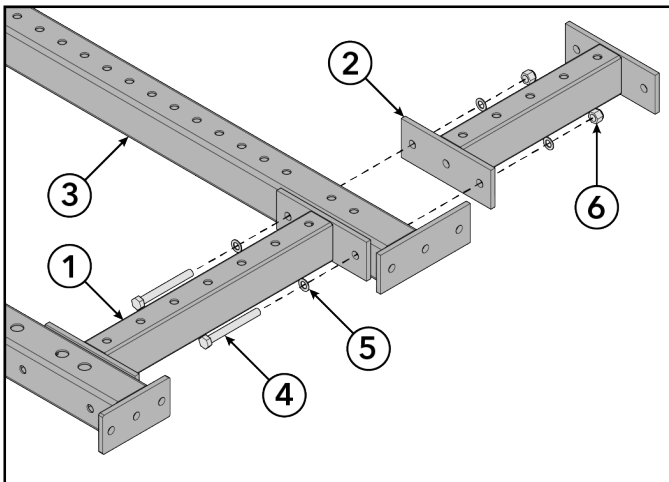

Item	Description	Qty.
1	Side Crossmember 21" (53 cm)	2
2	Side Crossmember 15" (38 cm)	2
3	Storage Upright	2
4	Bolt, HHB .5 x 4.5	4
5	Lock Washer, 1/2"	8
6	Lock Nut, 1/2"	4



Hand tighten hardware.

4. Install bolts, washers, and thin lock nuts securing stability feet to training uprights using two 3/4" wrenches.

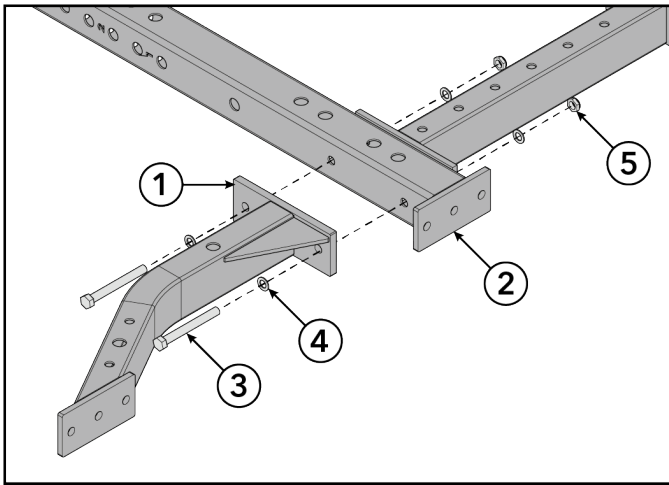

Item	Description	Qty.
1	Stability Feet	2
2	Training Upright	2
3	Bolt, HHB .5 x 4.5	4
4	Lock Washer, 1/2"	8
5	Lock Nut, 1/2" Thin	4



Hand tighten hardware.

NOTE: Stability feet are designed to lift the training uprights slightly off the floor. This is done to ensure solid contact to the floor at the furthest outside points.

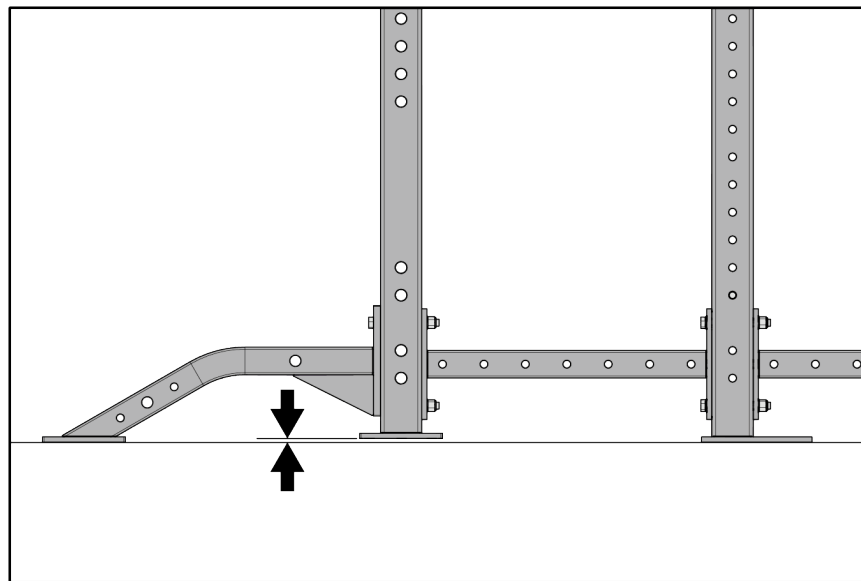

5. Stand assembled components upright.
6. Install bolts, backing washers, washers, and lock nuts securing super duty crossmember to storage uprights using two 3/4" wrenches.

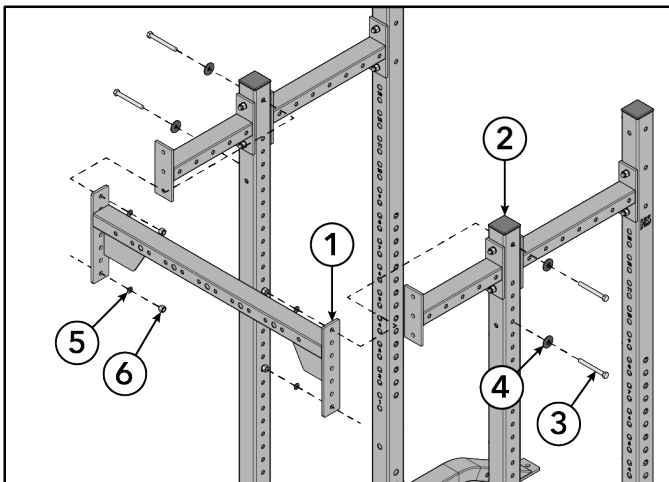

Item	Description	Qty.
1	Super Duty Crossmember	1
2	Storage Upright	2
3	Bolt, HHB .5 x 4.5	4
4	Backing Washer	4
5	Lock Washer, 1/2"	4
6	Lock Nut, 1/2"	4



Hand tighten hardware.

- Install bolts, backing washers, washers, and lock nuts securing front crossmember to training uprights using two 3/4" wrenches.

NOTE: Monkey bar front crossmember shown for example.

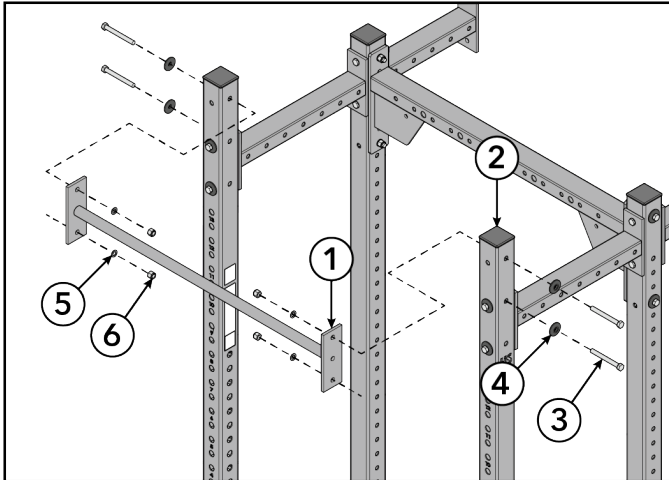

Item	Description	Qty.
1	Front Crossmember	1
2	Training Upright	2
3	Bolt, HHB .5 x 4.5	4
4	Backing Washer	4
5	Lock Washer, 1/2"	4
6	Lock Nut, 1/2"	4



Hand tighten hardware.

Assembled Half Rack #1

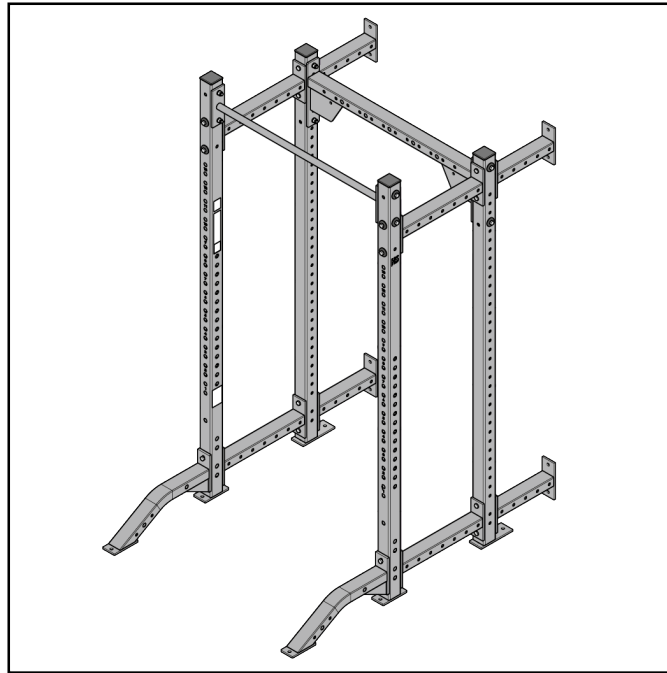

8. **NOTE: OPTIONAL:** The side crossmember and storage upright shown in this step are used on units with Double Storage options.

Install bolts, backing washers, washers, and lock nuts securing side crossmembers to tops of training uprights and storage uprights using two 3/4" wrenches.

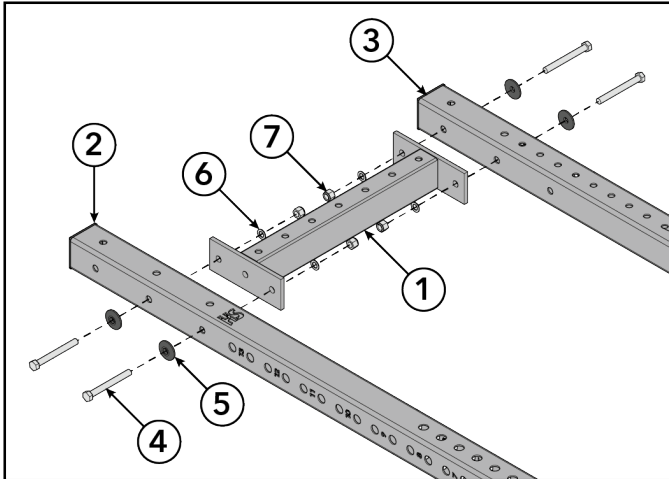

Item	Description	Qty.
1	Side Crossmember 21" (53 cm)	2
2	Training Upright	2
3	Storage Upright	2
4	Bolt, HHB .5 x 4.5	8
5	Backing Washer	8
6	Lock Washer, 1/2"	8
7	Lock Nut, 1/2"	8



Hand tighten hardware.

9. **NOTE: OPTIONAL:** The side crossmember and storage upright shown in this step are used on units with Double Storage options.

Install bolts, backing washers, washers, lock nuts, and thin lock nuts securing stability feet and side crossmembers to training uprights and storage uprights using two 3/4" wrenches.

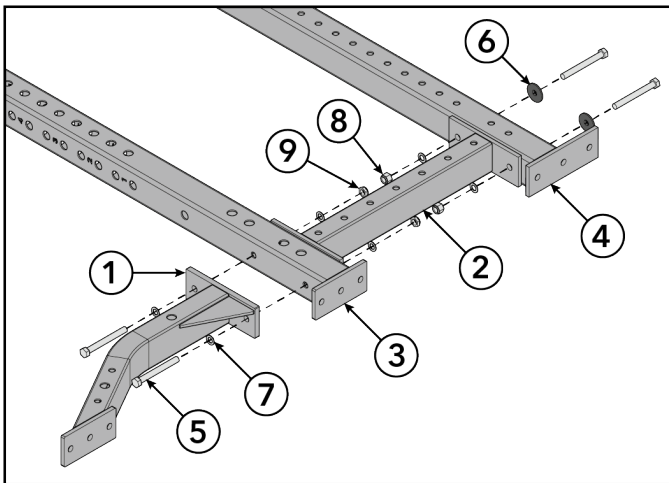

Item	Description	Qty.
1	Stability Feet	2
2	Side Crossmember	2
3	Training Upright	2
4	Storage Upright	2
5	Bolt, HHB .5 x 4.5	8
6	Backing Washer	4
7	Lock Washer, 1/2"	12
8	Lock Nut, 1/2"	4
9	Lock Nut, 1/2" Thin	4



Hand tighten hardware.

10. Stand assembled components upright.

11. Install bolts, backing washers, washers, and lock nuts securing front crossmember to training uprights using two 3/4" wrenches.

NOTE: Monkey bar front crossmember shown for example.

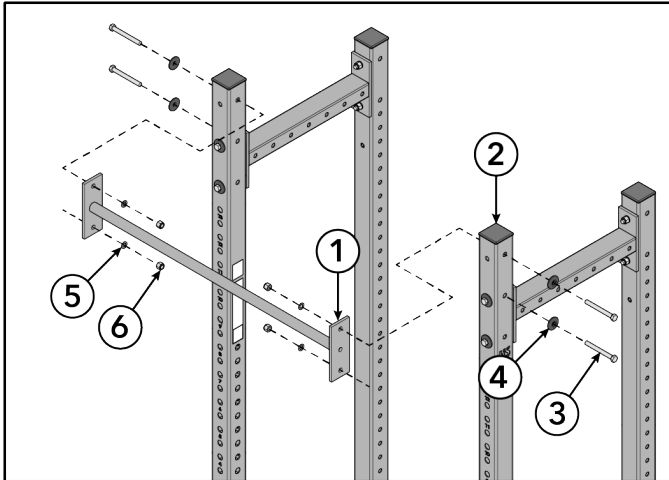

Item	Description	Qty.
1	Front Crossmember	1
2	Training Upright	2
3	Bolt, HHB .5 x 4.5	4
4	Backing Washer	4
5	Lock Washer, 1/2"	4
6	Lock Nut, 1/2"	4



Hand tighten hardware.

Assembled Half Rack #2

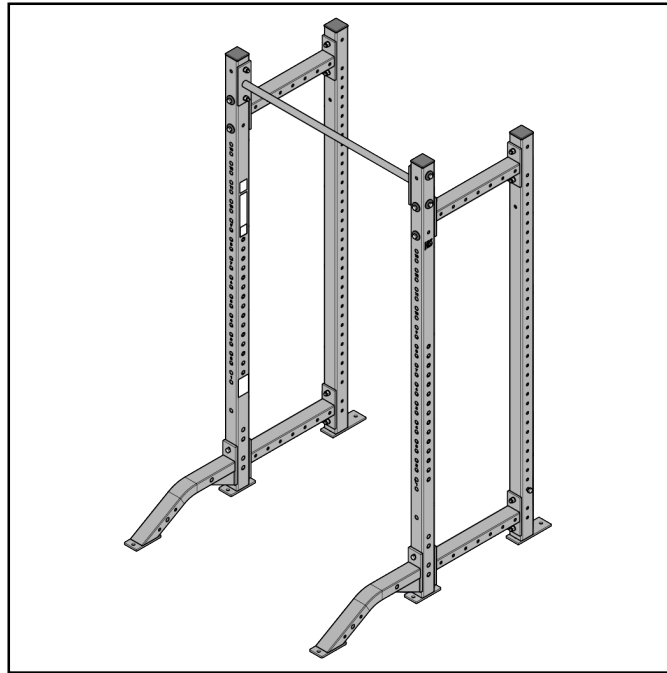

12. Align two assembled Half Racks.

Half Rack / Half Rack with Single Storage

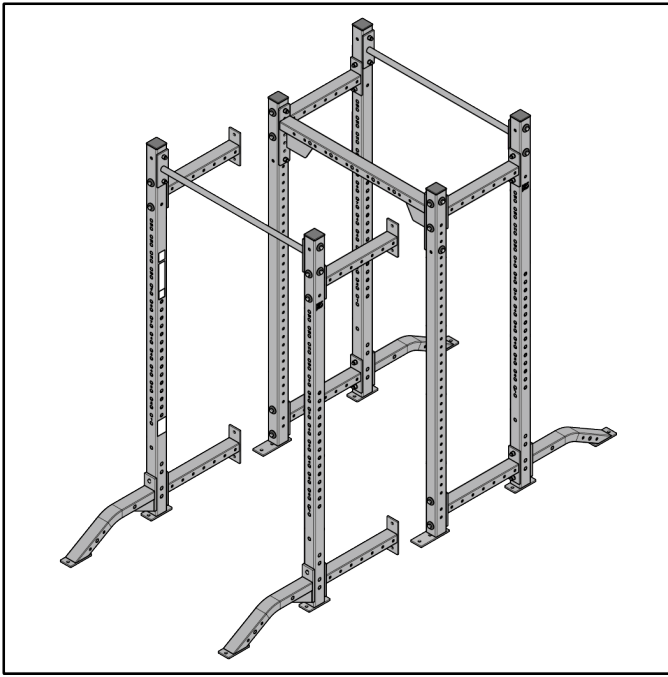

Half Rack / Half Rack with Double Storage

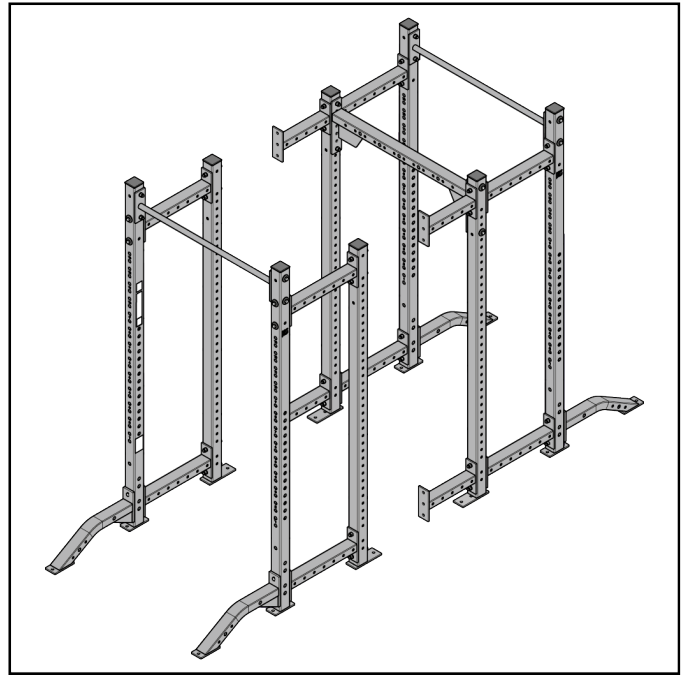

NOTE: On units with Double Storage options, the feet on the storage uprights face each other when assembled.

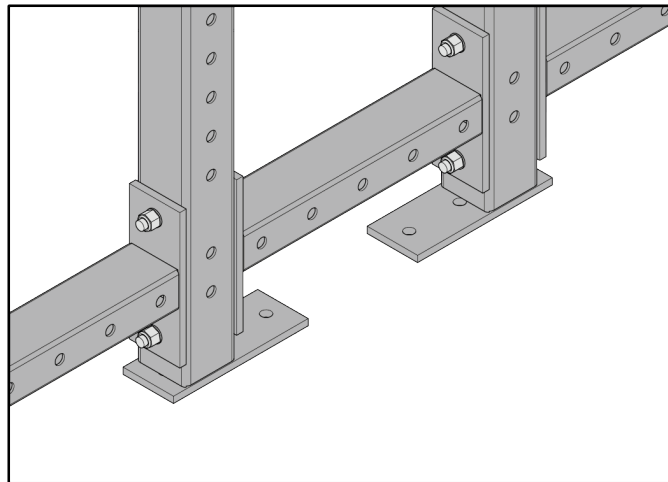

13. NOTE: OPTIONAL: The side crossmember and storage upright shown in this step are used on units with Double Storage options.

Remove bolts, backing washers, washers, and lock nuts securing side crossmembers to storage uprights using two 3/4" wrenches.

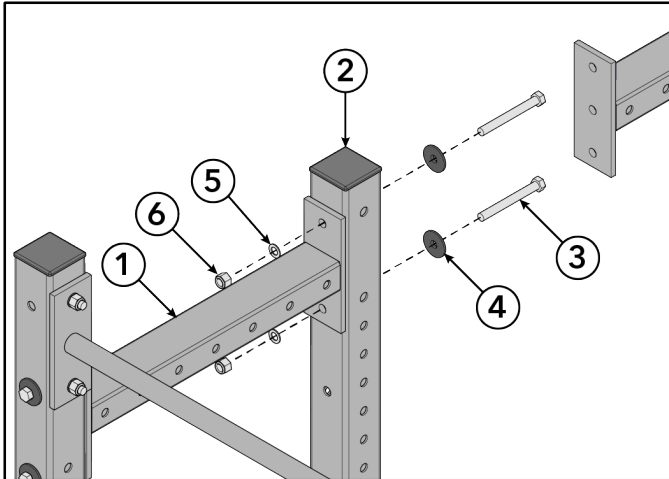

Item	Description	Qty.
1	Side Crossmember	4
2	Storage Upright	2
3	Bolt, HHB .5 x 4.5	8
4	Backing Washer	8
5	Lock Washer, 1/2"	8
6	Lock Nut, 1/2"	8

14. Align uprights from Assembled Half Rack #1 to side crossmembers on Assembled Half Rack #2.

15. Install bolts, washers, and lock nuts securing side crossmembers to storage uprights using two 3/4" wrenches.

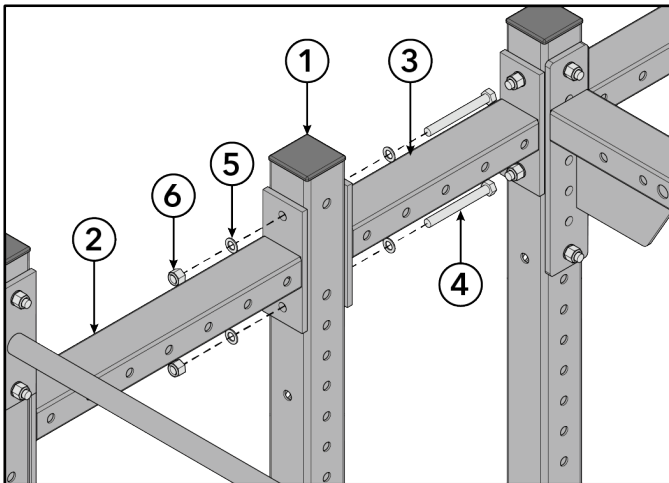

Item	Description	Qty.
1	Storage Upright	2
2	Side Crossmember 21" (53 cm)	4
3	Side Crossmember 15" (38 cm)	4
4	Bolt, HHB .5 x 4.5	8
5	Lock Washer, 1/2"	16
6	Lock Nut, 1/2"	8



Hand tighten hardware.

16. Tighten all loose hardware to 20-25 ft-lb (27-34 Nm) in the following order.

- a. Lower stability feet bolts to training uprights.
- b. Upper stability feet bolts to training uprights.
- c. Lower crossmembers to storage uprights.
- d. Upper crossmembers to training and storage uprights.
- e. Super duty crossmember to storage uprights.
- f. Front crossmember to training uprights.

Component List

Item	Description	Qty.
<i>Combo Racks consist of components from the Half Rack or Power Rack .</i>		

Optional Components

Weight Plate Storage

When adding and removing weight plates from weight horns, always evenly load and unload (left/right side) weight plates to avoid tipping.

Below is the recommended bumper plate storage configuration:

- (2) 10 lb plates
- (2) 25 lb plates
- (2) 45 lb plates
- (4) 45 lb plates

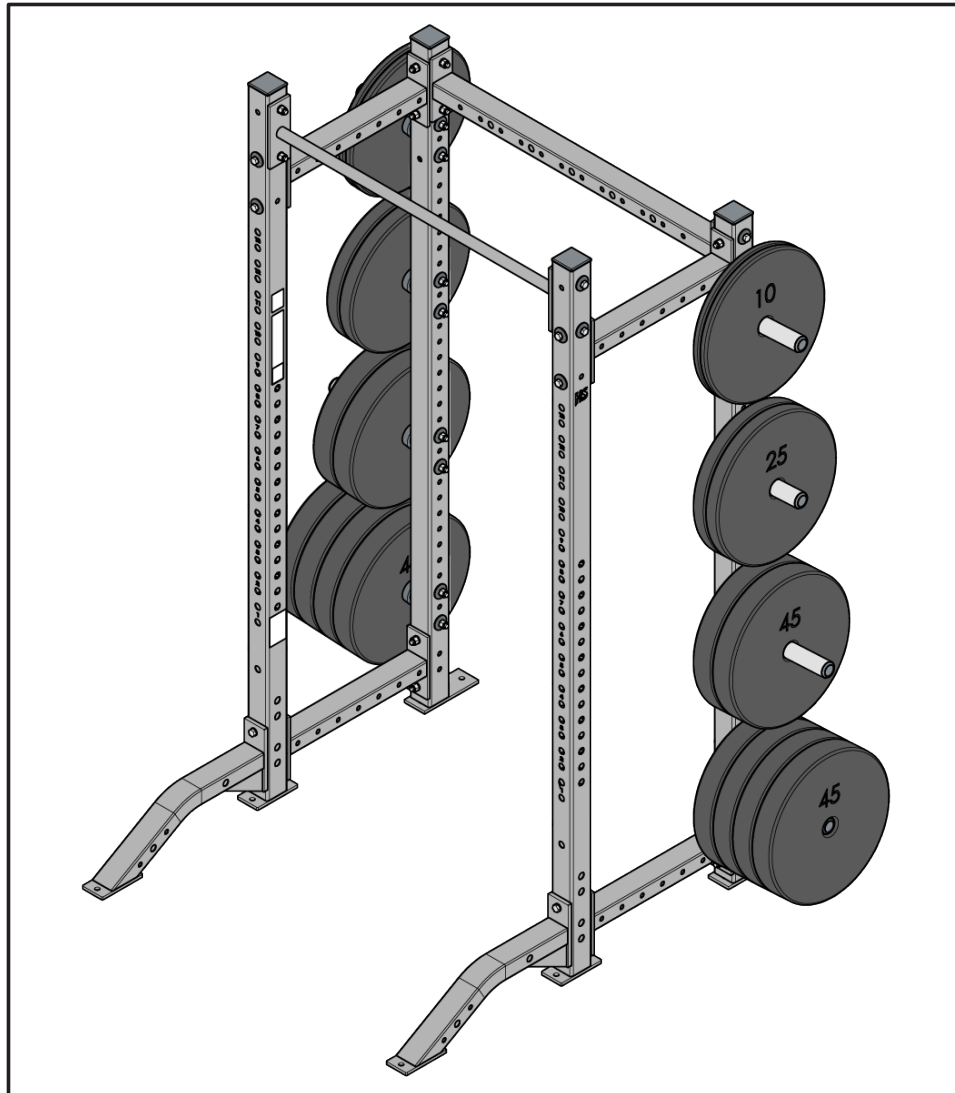

Install Weight Horns

Install bolts, washers, backing washers, and lock nuts securing weight horns to storage uprights using two 3/4" wrenches.

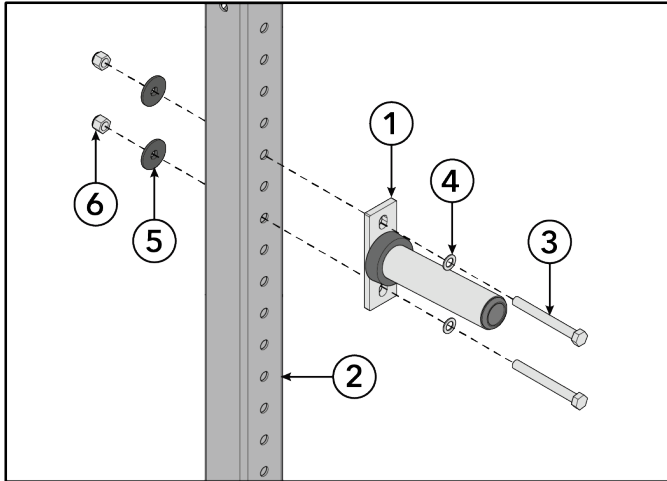

Item	Description	Qty.
1	Weight Horn	8
2	Storage Upright	2
3	Bolt, HHB .5 x 4.5	16
4	Lock Washer, 1/2"	16
5	Backing Washer	16
6	Lock Nut, 1/2"	16



Tighten hardware to 20-25 ft-lb (27-34 Nm).

NOTE: Weight horns can be installed in two configurations depending on the type of weight plates being used.

Bumper Plate Configuration

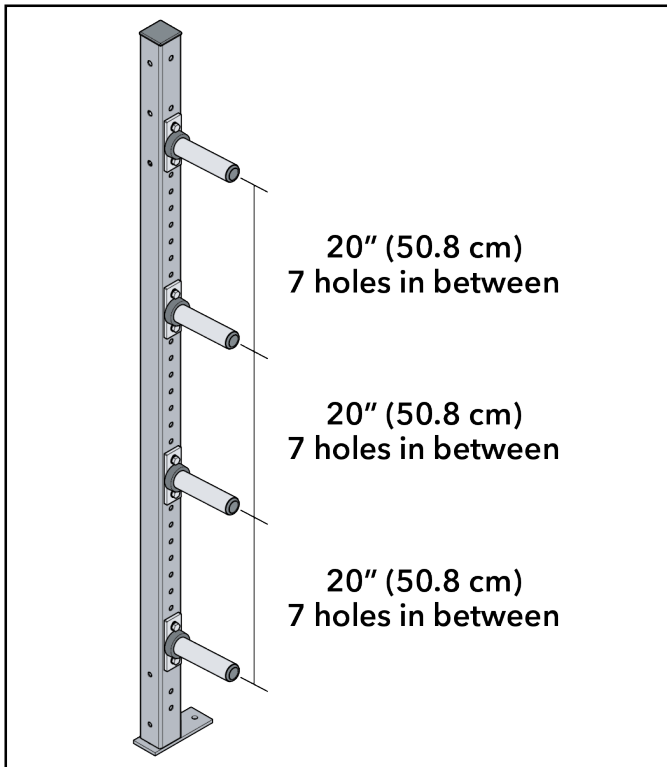

Standard Plate Configuration

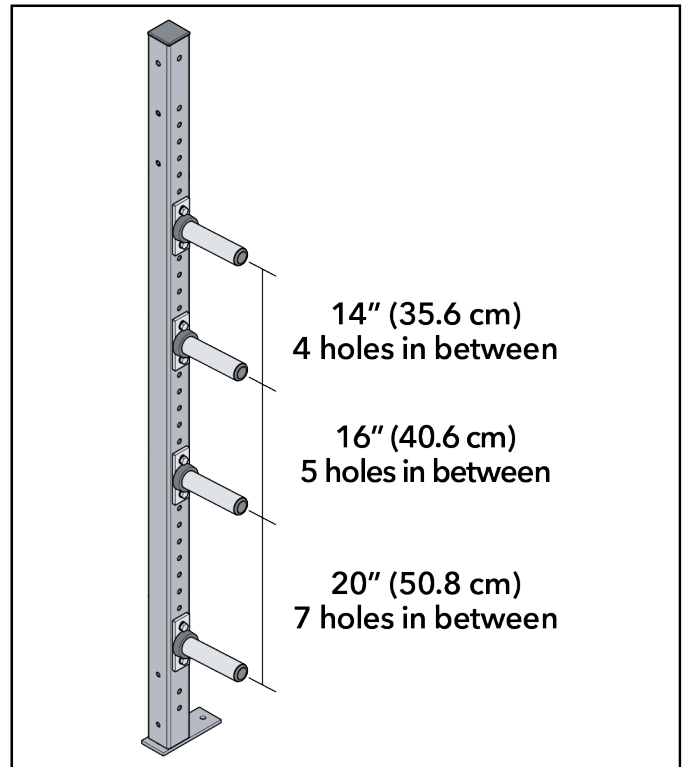

Install Flexible Bar Catches

Flexible bar catches can be installed to Power Racks, Power / Half Combo Racks, and Power / Power Combo Racks.

Install flexible bar catches to training uprights by lifting the latch and sliding the pivot shaft into training upright hole.

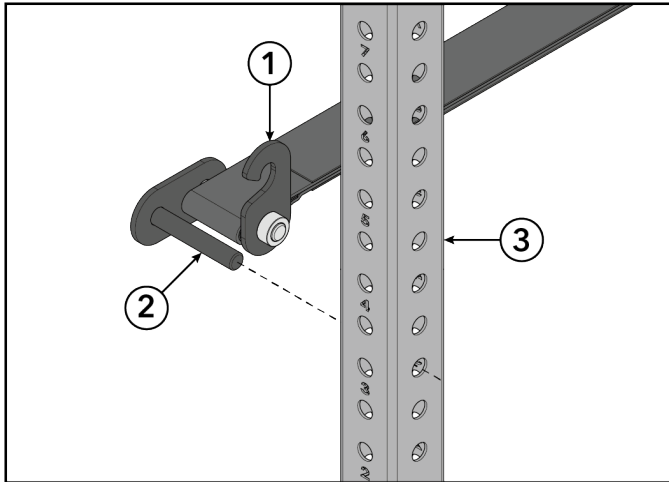

Item	Description	Qty.
1	Latch	4
2	Pivot Shaft	4
3	Training Upright	4

NOTE: Latches are designed to go over the top of pivot shafts.

Correct Latch Direction

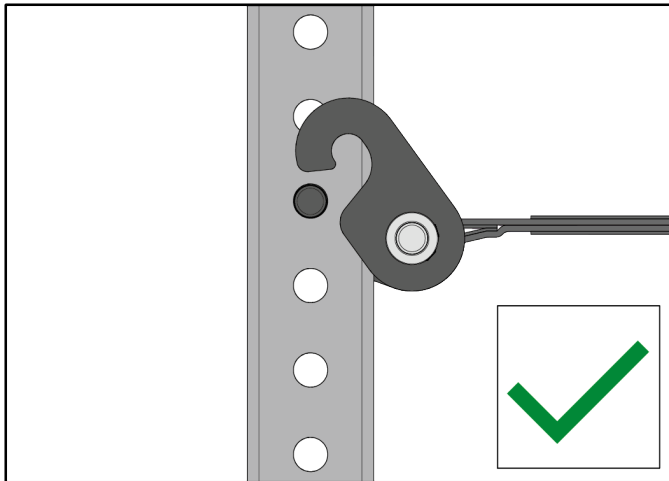

Incorrect Latch Direction

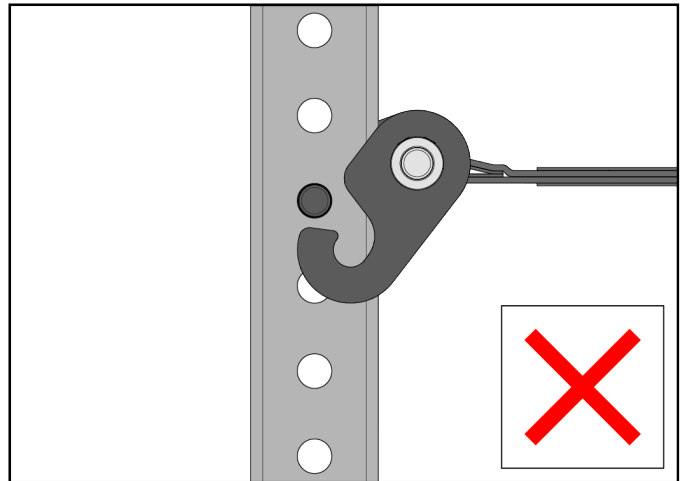

NOTE: Do NOT offset flexible bar catches more than three hole positions.

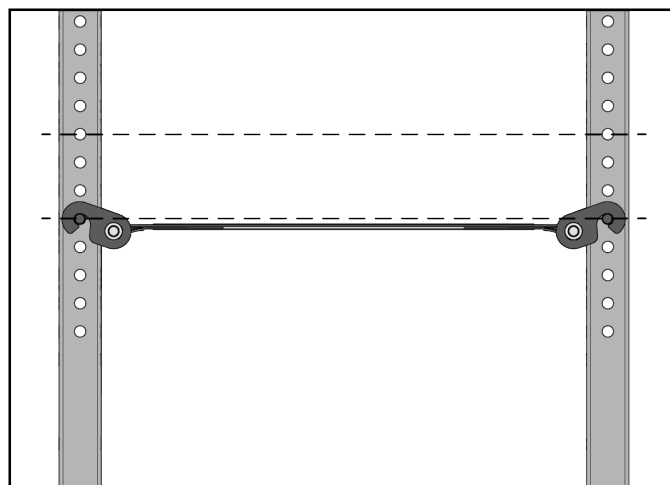

Install Custom Sign

The super duty crossmember is required to install the custom sign.

Install screws, washers, spacers, and lock nuts securing optional custom sign and backer plate to super duty crossmember using a 7mm Allen wrench and 17mm wrench.

NOTE: Single custom sign can be installed on the front or rear of super duty crossmember.

Single Custom Sign

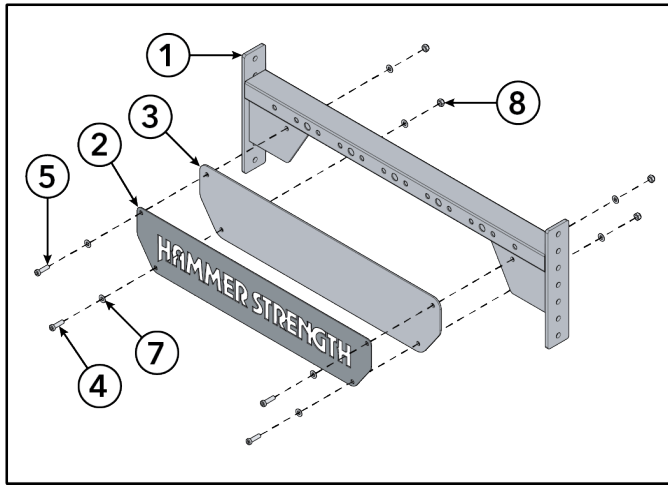

Double Custom Sign

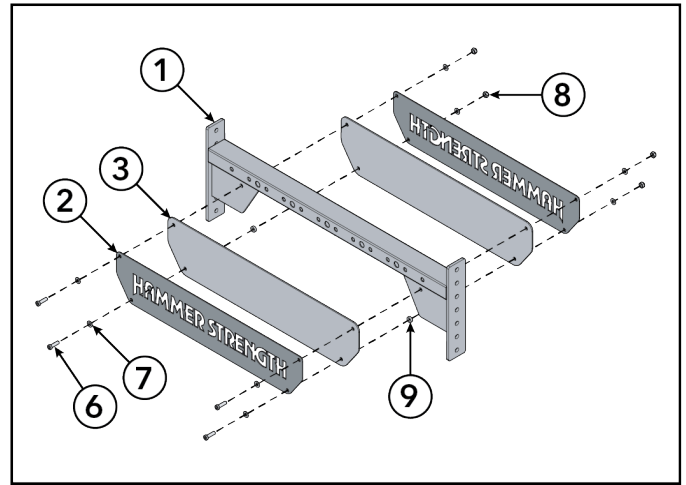

Item	Description	Qty.
1	Super Duty Crossmember	1
2	Custom Sign	1 or 2
3	Backer Plate	1 or 2
4	Screw, M10 x 1.5, 25mm	2
5	Screw, M10 x 1.5, 30mm	2
6	Screw, M10 x 1.5, 35mm	4
7	Flat Washer, 3/8"	8
8	Lock Nut, M10	4
9	Spacer	2



Tighten hardware to 40-50 in-lb (4.5-5.6 Nm).

3. Product Information

Squat Stand (HDW-SQST)

Product Specs

Size (L x W x H*):	in = 53 x 48 x 96	cm = 135 x 122 x 244
Live Area (L x W):	in = 84 x 120	cm = 213 x 305
Rack Weight:	153 lbs	69 kg
Max User Weight:	350 lbs	159 kg
*Max Training Weight:	675 lbs	306 kg
Training Upright Heights:	in = 86, 91 or 96	cm = 218, 231 or 244

NOTE:

- Height (H) varies depending on Training Upright size.
- Max Training Weight varies depending on bar catch selection.

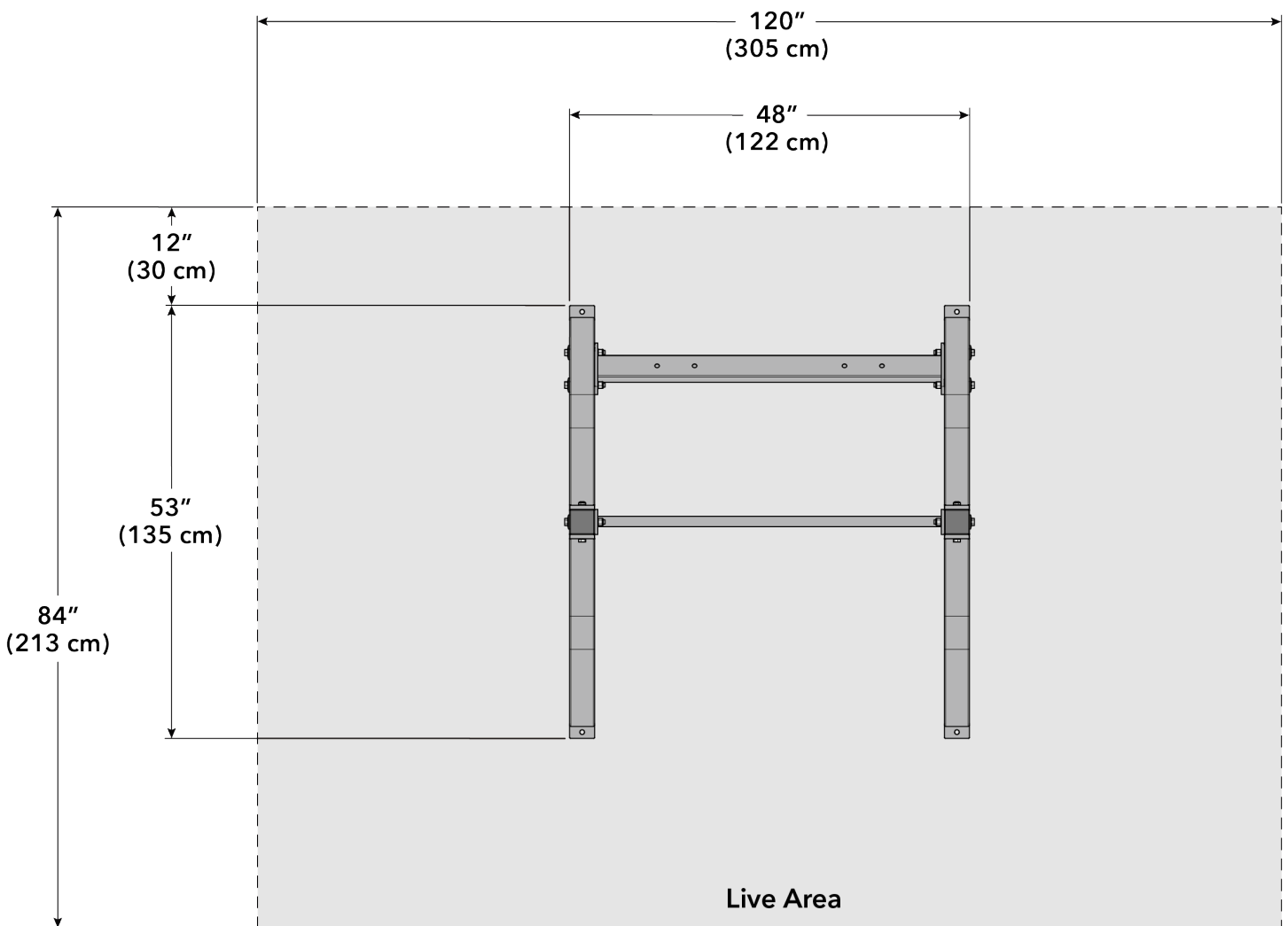

Half Rack (HDW-HR, HDW-HR-STRD and HDW-HR8-STRD)

Product Specs

*Size (L x W x H):	in = 50 x 48 x 96	cm = 127 x 122 x 244
Live Area (L x W):	in = 84 x 120	cm = 213 x 305
Rack Weight:	211 lbs	96 kg
Max User Weight:	350 lbs	159 kg
*Max Training Weight:	675 lbs	306 kg
Training Upright Heights:	in = 86, 91 or 96	cm = 218, 231 or 244
Storage Upright Height:	in = 86	cm = 218

NOTE:

- Length (L) varies depending on Depth Connector size and bolt-to-floor option.
- Width (W) does not include attached weight horns.
- Height (H) varies depending on Training Upright size.
- Max Training Weight varies depending on bar catch selection.

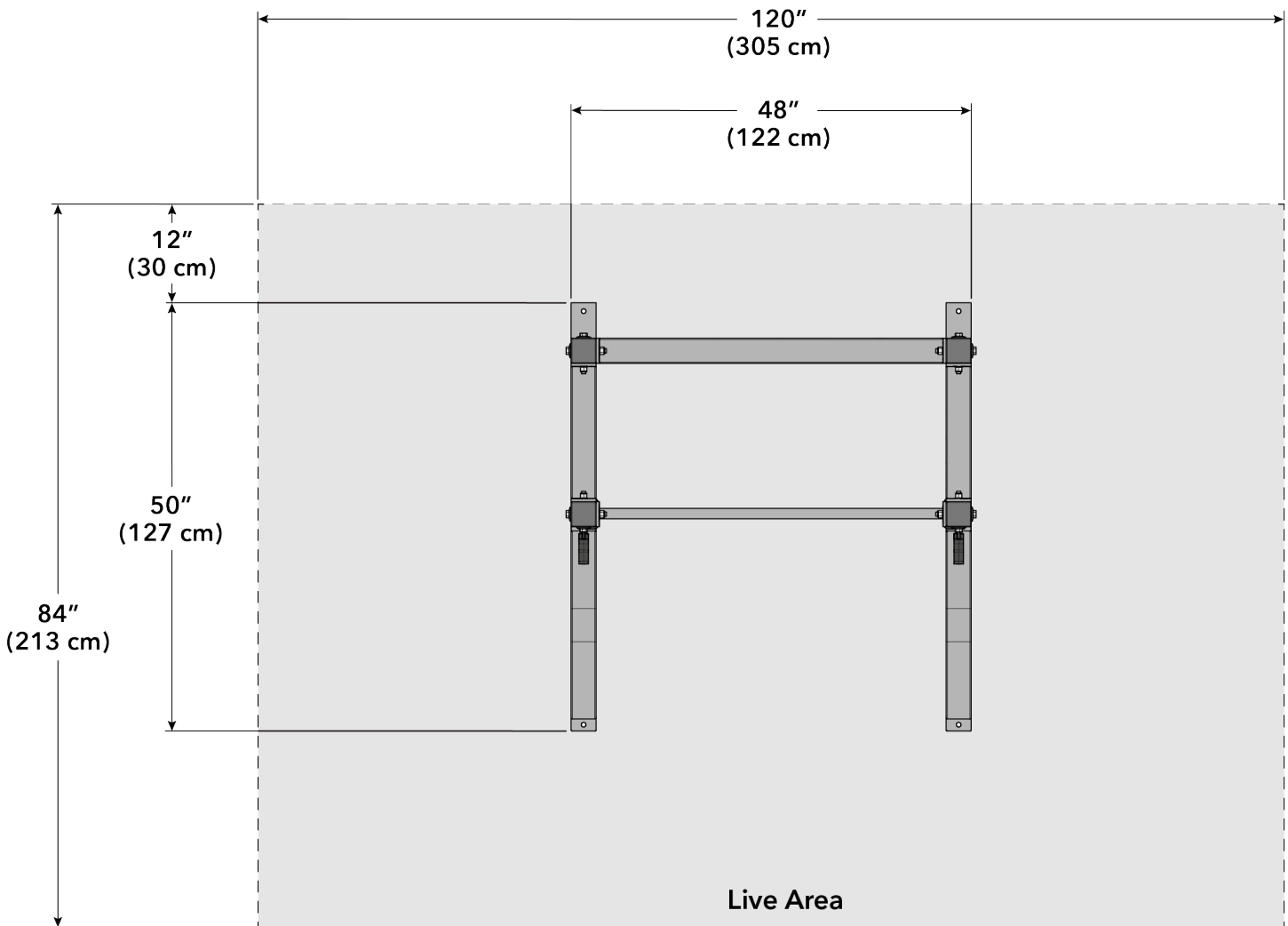

Power Rack (HDW-PR, HDW-PR-STRD and HDW-PR-STRD)

Product Specs

*Size (L x W x H):	in = 44 x 48 x 96	cm = 112 x 122 x 244
Live Area (L x W):	in = 120 x 120	cm = 305 x 305
Rack Weight:	224 lbs	102 kg
Max User Weight:	350 lbs	159 kg
*Max Training Weight:	675 lbs	306 kg
Training Upright Heights:	in = 86, 91 or 96	cm = 218, 231 or 244
Storage Upright Height:	in = 86	cm = 218

NOTE:

- Length (L) varies depending on 4-Post or 6-Post and bolt-to-floor option.
- Width (W) does not include attached weight horns.
- Height (H) varies depending on Training Upright size.
- Max Training Weight varies depending on bar catch selection.

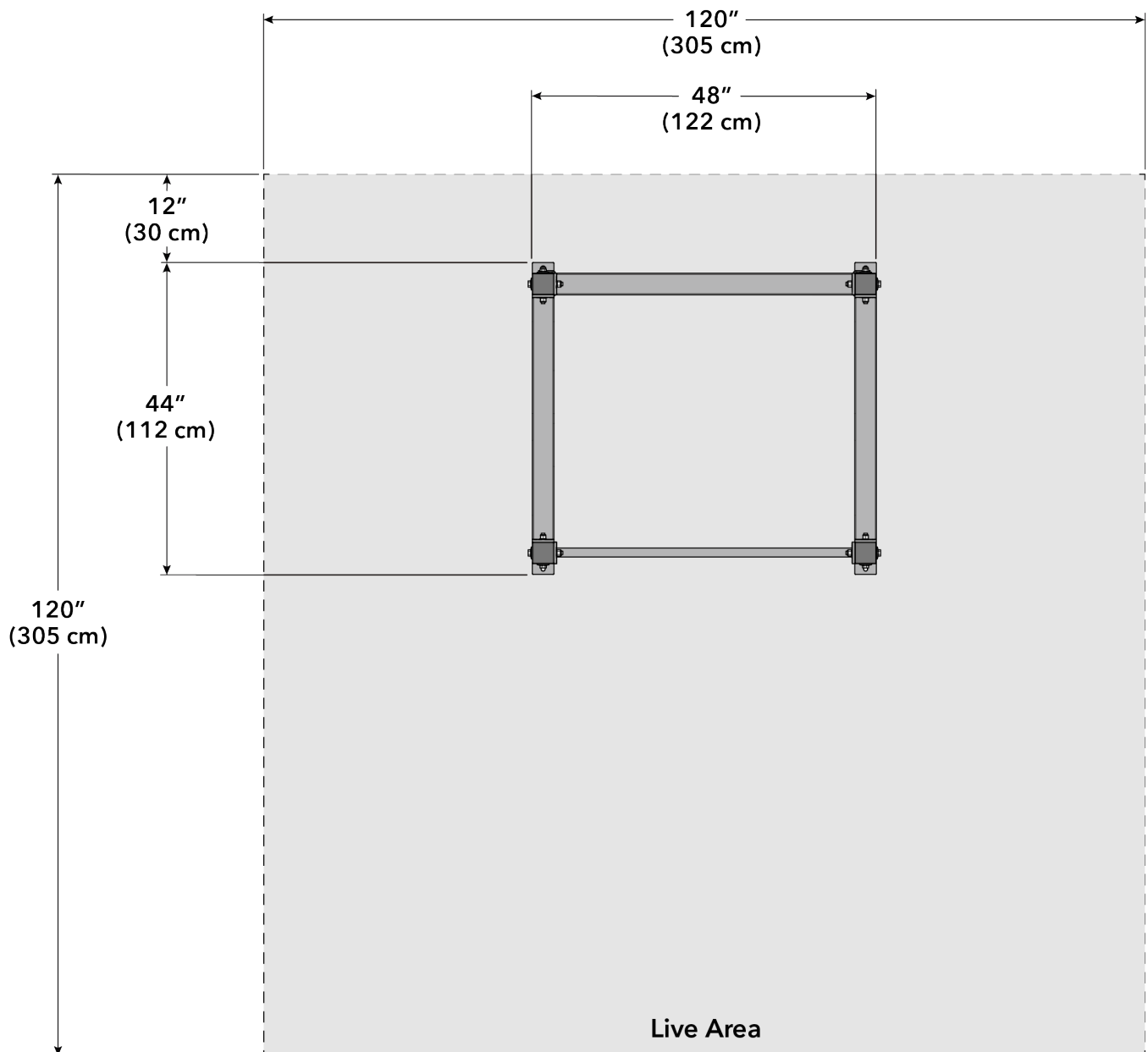

Combo Rack (HDW-HHCR, HDW-PHCR, HDW-PPCR)

Half / Half Combo Rack (HDW-HHCR)

	Short Single Storage 15" Depths + 1 Upright	Long Single Storage 21" Depths + 1 Upright	Short Double Storage 15" Depths + 2 Uprights	Long Double Storage 21" Depths + 2 Uprights
Size (L x W):	in = 89 x 48 cm = 226 x 122	in = 101 x 48 cm = 257 x 122	in = 107 x 48 cm = 272 x 122	in = 119 x 48 cm = 302 x 122
Live Area (L x W):	in = 185 x 120 cm = 470 x 305	in = 197 x 120 cm = 500 x 305	in = 203 x 120 cm = 516 x 305	in = 215 x 120 cm = 546 x 305
Rack Weight:	356 lbs 161 kg	372 lbs 169 kg	458 lbs 208 kg	474 lbs 215 kg

Power / Half Combo Rack (HDW-PHCR)

	Short Single Storage 15" Depths + 1 Upright	Long Single Storage 21" Depths + 1 Upright	Short Double Storage 15" Depths + 2 Uprights	Long Double Storage 21" Depths + 2 Uprights
Size (L x W):	in = 101.5 x 48 cm = 258 x 122	in = 113.5 x 48 cm = 288 x 122	in = 119.5 x 48 cm = 304 x 122	in = 131.5 x 48 cm = 334 x 122
Live Area (L x W):	in = 197.5 x 120 cm = 502 x 305	in = 209.5 x 120 cm = 532 x 305	in = 215.5 x 120 cm = 547 x 305	in = 227.5 x 120 cm = 578 x 305
Rack Weight:	471 lbs 214 kg	487 lbs 221 kg	573 lbs 260 kg	589 lbs 267 kg

Power / Power Combo Rack (HDW-PPCR)

	Short Single Storage 15" Depths + 1 Upright	Long Single Storage 21" Depths + 1 Upright	Short Double Storage 15" Depths + 2 Uprights	Long Double Storage 21" Depths + 2 Uprights
Size (L x W):	in = 114 x 48 cm = 290 x 122	in = 126 x 48 cm = 320 x 122	in = 132 x 48 cm = 335 x 122	in = 144 x 48 cm = 366 x 122
Live Area (L x W):	in = 210 x 120 cm = 533 x 305	in = 222 x 120 cm = 564 x 305	in = 228 x 120 cm = 579 x 305	in = 240 x 120 cm = 610 x 305
Rack Weight:	586 lbs 266 kg	602 lbs 273 kg	638 lbs 289 kg	646 lbs 293 kg

General Product Specs

Max User Weight:	350 lbs	159 kg
*Max Training Weight:	675 lbs	306 kg
Training Upright Heights:	in = 86, 91 or 96	cm = 218, 231 or 244
Storage Upright Height:	in = 86	cm = 218

NOTE:

- All Half / Half Combo Rack depths have 2 pairs of stability feet, increasing the depth by 50" (127 cm).
- All Power / Half Combo Rack depths have 1 pair of stability feet, increasing the depth by 25" (64 cm).
- Bolting the Combo Racks to the floor allows all stability feet to be removed.
- Width and Weight do not include weight horns.
- Max Training Weight varies depending on bar catch selection.

Half / Half Combo Rack (HDW-HHCR) with Long Double Storage

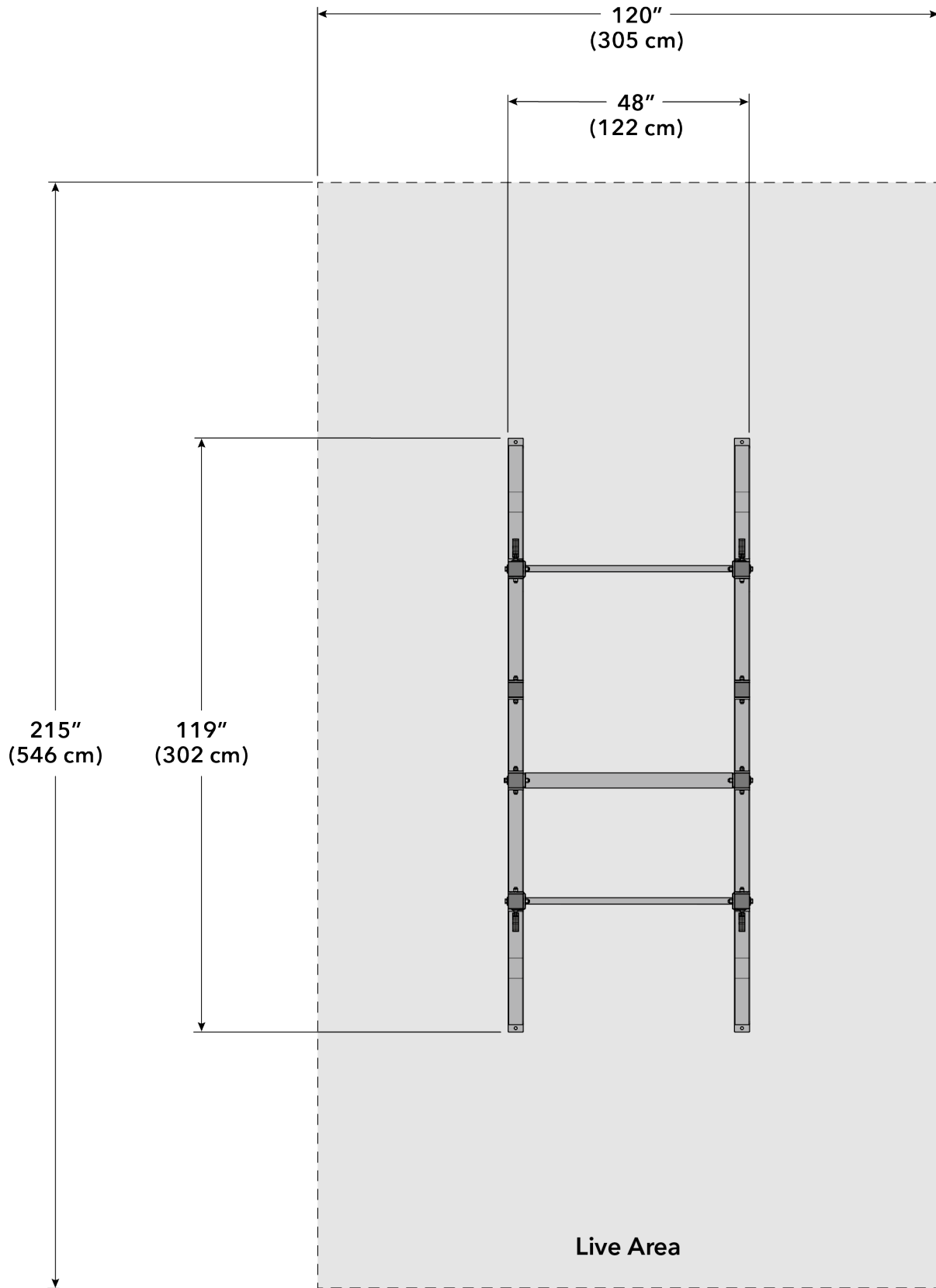

Power / Half Combo Rack (HDW-PHCR) with Long Double Storage

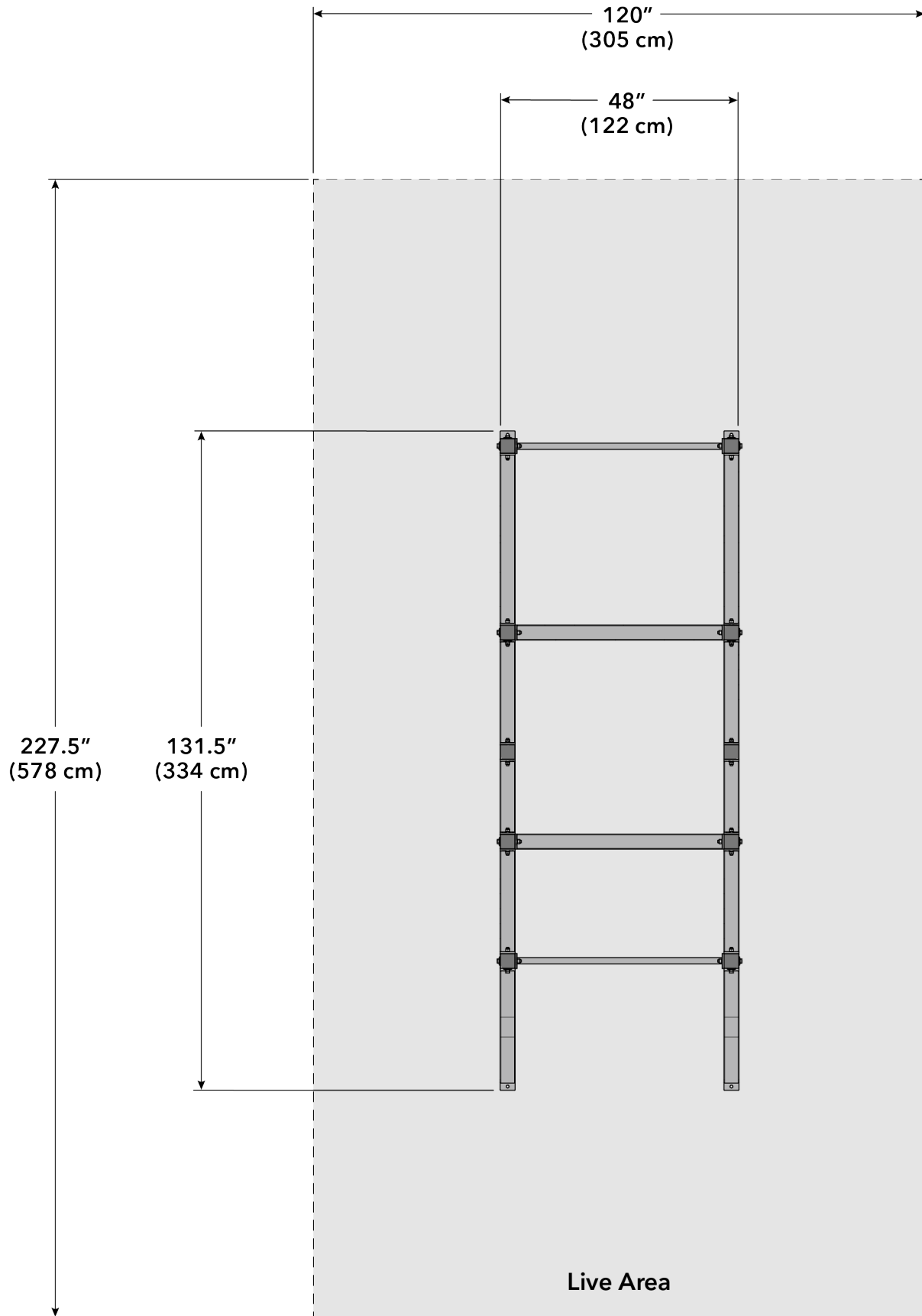

Power / Power Combo Rack (HDW-PPCR) with Long Double Storage

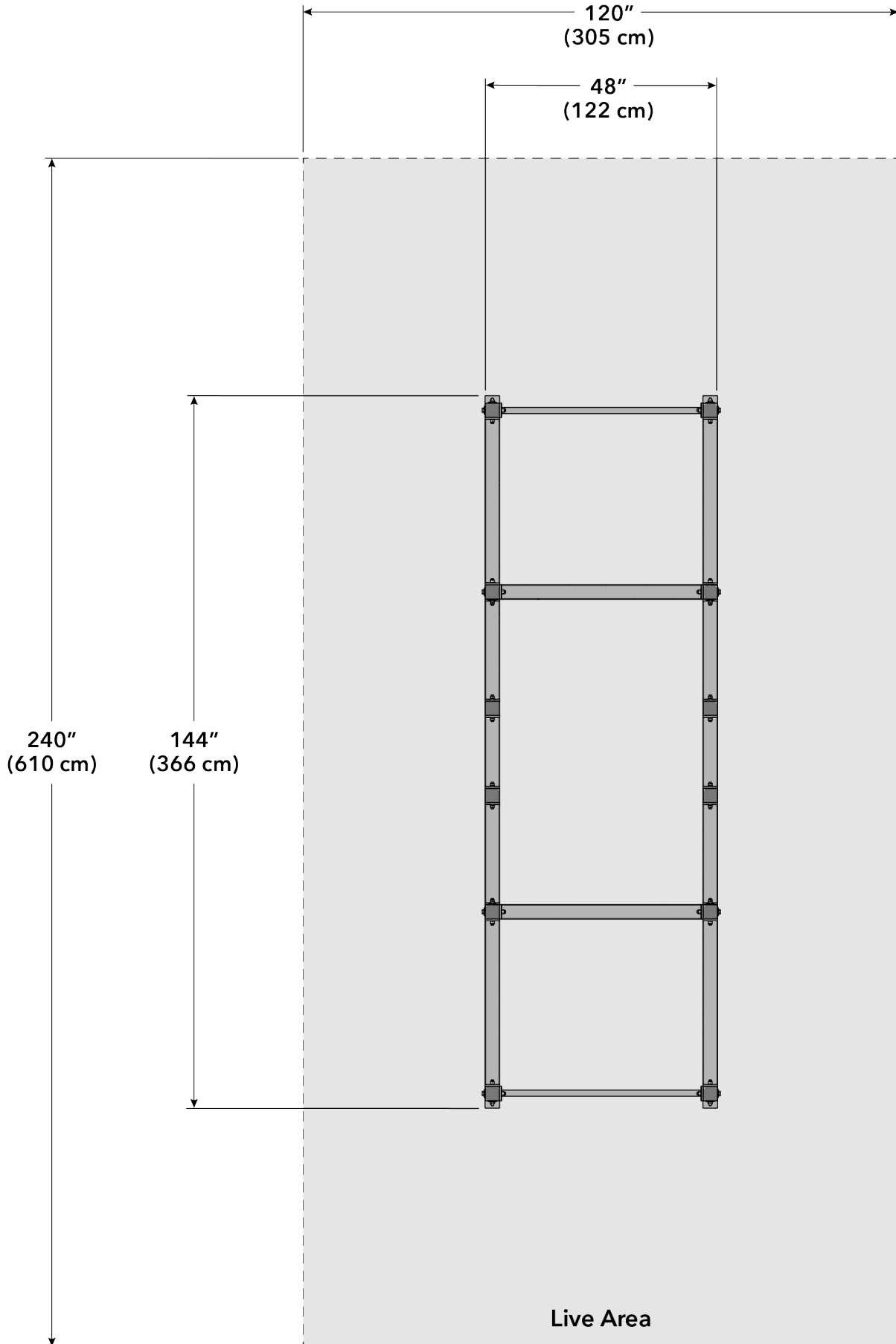

4. Exercise

General Exercise Information

Intended Use

The intended commercial use of this machine is to aid exercise and improve general physical fitness. Multiple exercises can be performed using this product. It is the responsibility of the owner to ensure exercisers understand general use and only perform recommended exercises that do not compromise the stability of the product or put the user at risk.

Prior to Exercise

Prior to starting a training program, get a complete physical exam to make sure your physician agrees that you are ready. Always warm-up your muscles before a workout. A cardio warm-up followed by stretching is typically recommended.

Start Your Program Conservatively

Choose weights you can easily lift in the first several weeks. Typically, a full range of motion is recommended, but consult a qualified professional if you have questions about whether a full range of motion is appropriate for you due to existing limitations, injury or discomfort. Injuries to health may result from incorrect or excessive training.

A "repetition" (rep) is defined as one complete movement through an exercise, returning to the start position. A "set" is a continuous series of reps, usually between 6-15. During your workout the number of reps you perform in a set depends on your goal. To build muscle and strength, often fewer reps (6 - 8) with heavier weight is recommended in each set. To build endurance, more reps (12-15) with lighter weight is typically recommended.

At the end of your workout, cool down in a similar way to your warm-up.

5. Maintenance Procedures

Maintenance Schedule

ACTION	DAILY	WEEKLY	MONTHLY	AS NEEDED
WAX				
Frames				•
INSPECT				
Accessories		•		
Paint			•	
Hardware		•		
Frame		•		

Clean

- Frame with a mild soap and water.

Wax

- Frames with a standard, non-abrasive, wax finish.

Inspect

- Hardware. Check for loosening. Tighten as required.
- Frames. Inspect for wear and damage.
- For paint chips. Fill in immediately with manufacturers touch-up paint.
- Straps for Power Rack Flexible Bar Catches to be inspected for cuts, frays, or other damage. Any strap showing sign of damage should be replaced immediately.

Once a Week

- Visually inspect all hardware for loosening, tampering or wear.
- Inspect all accessories, connecting links, and carabiner clips for wear.

Once a Month

- Inspect hardware on all machines and tighten any bolts or nuts that may have loosened over the life of the product.

Notes

- Use polishing compound (such as car wax) and remove shoe scuffs from powder coated surfaces as necessary.

Approved and Compatible Cleaners

Two preferred cleaners have been approved by reliability experts: PureGreen 24 and Gym Wipes. Both cleaners will safely and effectively remove dirt, grime and sweat from equipment. PureGreen 24 and the Antibacterial Force formula of Gym Wipes are both disinfectants that are effective against MRSA and H1N1.

PureGreen 24 is available in a spray which is convenient to use. Apply the spray to a microfiber cloth and wipe down the equipment. Use PureGreen 24 on the equipment for at least 2 minutes for general disinfection purposes and at least 10 minutes for fungus and viral control.

Gym Wipes are large, durable pre-moistened wipes to use on the equipment before and after workouts. Use Gym Wipes on the equipment for at least 2 minutes for general disinfection purposes.

Contact Customer Support Services to order these cleaners (1-800-351-3737 or email: customersupport@lifefitness.com).

Mild soap and water or a mild non-abrasive household cleaner can also be used to clean the display and all exterior surfaces. Use a soft microfiber cloth only. Apply the cleaner to the microfiber cloth before cleaning. DO NOT use ammonia or acid based cleaners. DO NOT use abrasive cleaners. DO NOT use paper towels. DO NOT apply cleaners directly to the equipment surfaces.

Removal of Paint, Marking Pens, or Labels

- Butyl cellosolve works well for removal of paints, marking pen inks, lipstick, etc.
- Labels, stickers, etc. may be removed using kerosene. When the solvent will not penetrate sticker material, apply heat (hair dryer) to soften the adhesive and promote removal. GASOLINE SHOULD NOT BE USED.

6. Warranty

What is Covered

This Life Fitness commercial exercise equipment product is warranted to be free of all defects in material and workmanship.

Who is Covered

The original purchaser or any person receiving the product as a gift from the original purchaser.

Who Pays Transportation and Insurance For Service

If the Product or any covered part must be returned to a service facility for repairs, We, Life Fitness, will pay all transportation and insurance charges for the first year. You are responsible for transportation and insurance charge after the first year.

What We Will Do To Correct Covered Defects

We will ship to you any new or rebuilt replacement part or component, or at our option, replace the Product. Such replacement parts are warranted for the remaining portion of the original warranty period.

What is Not Covered

Any failures or damage caused by unauthorized service, misuse, accident, negligence, improper assembly or installation, debris resulting from any construction activities in the Product's environment, rust or corrosion as a result of the Product's location, alterations or modifications without our written authorization, or by failure on your part to use, operate and maintain the Product as set out in your Operation Manual.

All terms of this warranty are void if this product is moved beyond the continental borders of the United States of America (excluding Alaska, Hawaii and Canada) and are then subject to the terms provided by that country's local authorized Life Fitness representative.

Owner's Manual

It is VERY IMPORTANT THAT YOU READ THIS MANUAL before operating the Product. Remember to perform the periodic maintenance requirements specified in the Manual to assure proper operation and your continued satisfaction.

Exclusive Warranty

THIS LIMITED WARRANTY IS IN LIEU OF ALL OTHER WARRANTIES OF ANY KIND EITHER EXPRESSED OR IMPLIED, INCLUDING BUT NOT LIMITED TO THE IMPLIED WARRANTIES OF MERCHANTABILITY AND FITNESS FOR A PARTICULAR PURPOSE, AND ALL OTHER OBLIGATIONS OR LIABILITIES ON OUR PART. We neither assume nor authorize any person to assure for us any other obligation or liability concerning the sale of this Product. Under no circumstances shall we be liable under this warranty, or otherwise, of any damage to any person or property, including any lost profits or lost savings, for any special, indirect, secondary, incidental or consequential damages of any nature arising out of the use of or inability to use this Product. Some states do not allow the exclusion or limitation of implied warranties or of liability for incidental or consequential damages, so the above limitations or exclusions may not apply to you. Warranty coverages and terms may differ outside the United States. Please contact the Life Fitness office servicing your country (contact information found at the front of this manual) or visit the applicable local Life Fitness website to receive the specific warranty information for your country.

Changes in Warranty Not Authorized

No one is authorized to change, modify or extend the terms of this limited warranty.

Effects of State Laws

This warranty gives you specific legal rights, and you may have other rights which vary from state to state and country by country.

Terms of Warranty Coverage

Please use the link below to access component warranty terms:



7. Cable Handling Guide

Cable Connections, Seating, and Installation

Cable connections with threaded cable ends are required to be installed and maintained following the specifications identified below. Failure to follow these specifications can lead to the dislocation of the threaded cable during use and can cause serious injury. Along with securing the threaded cable end and jam nut, it is important to check the entire unit and ensure that all hardware is securely fastened and not left loose upon completion of cable installation.

⚠ WARNING: Use of non certified “techs” note: Service warranties may be void if a non-Life Fitness-certified technician performs service work. Replacement of any strength cables should be performed by a Life Fitness certified technician.

CABLE COMPONENTS

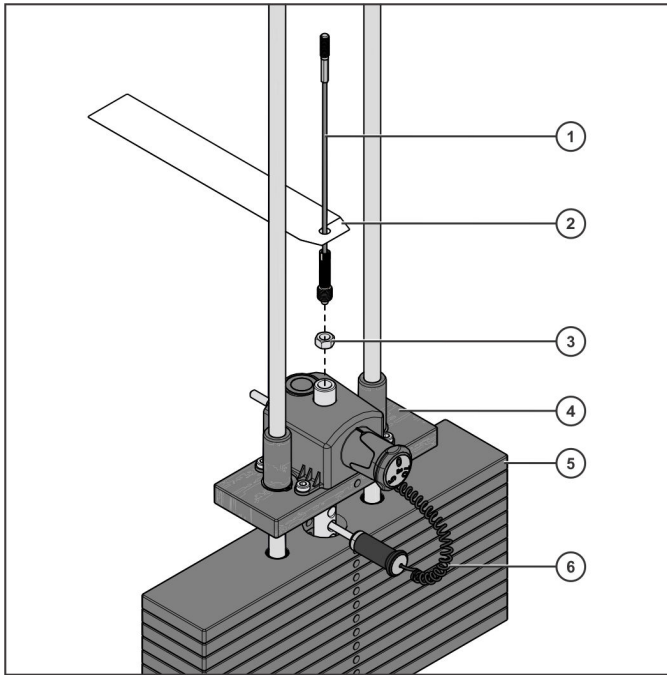

Item	Description	Qty.
1	Cable Assembly	1
2	Cable Hangtag	1
3	Jam Nut	1
4	Head Plate Assembly	1
5	Weight Plates	12
6	Weight Selector Pin Assembly	1

- Jam nuts must be tightened toward the head plate assembly and frame anchor. Torque the jam nuts to 20-25 ft-lbs. (27.2 - 24.0 Nm).
- Cable Hangtags to be removed by customer only.

Cabling Procedure

Direct Terminal

Direct terminal is when the cable is terminated directly at the head plate assembly.

1. Thread cable into the head plate assembly at least to the jam nut. This will ensure the proper minimum thread engagement depth of 1/2 inch (12.7mm).

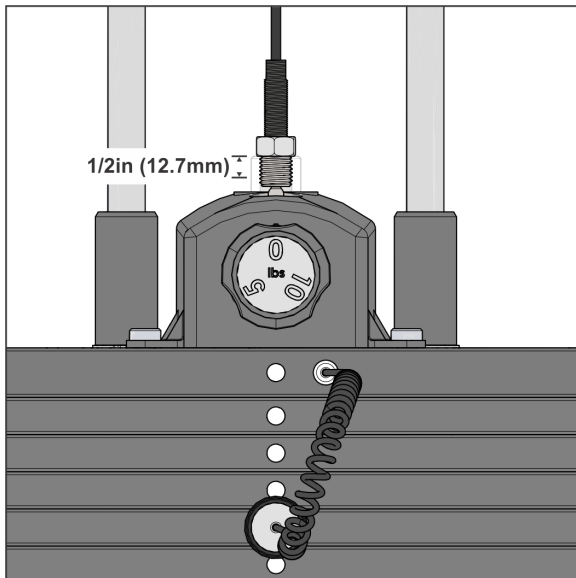

2. Cycle the machine to ensure that it is in proper working order.
3. Check the cable to ensure there is proper tension.
4. Tighten jam nut to 20-25 ft-lbs. (27.2 - 34.0 Nm).

Remote Terminal

Remote terminal is when the cable is terminated away from the head plate assembly; either at the frame, workarm, etc.

1. Measure the threaded end of the pulley assembly and cable.
2. Screw the jam nuts onto the end of the thread on the pulley assembly and cable.
3. Thread the pulley assembly into the head plate assembly at least 1/2 inch (12.7mm).
4. Thread the cable into the remote terminal.
5. Measure the exposed threads to verify that the proper thread engagement, minimum 1/2 inch (12.7mm), is screwed into the terminations.

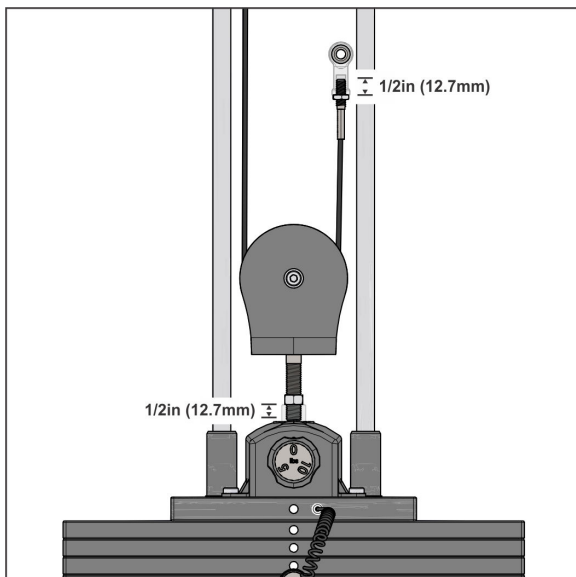

6. Cycle the machine to ensure that it is in proper working order.
7. Check the cable to ensure there is proper tension.
8. Torque the jam nuts to 20-25 ft-lbs. (27.2 - 34.0 Nm).

Tensioning Cable

Cable should have enough tension so it stays seated into the pulley but not so tight that it raises the head plate off the weight plate below it.

1. If the head plate has lifted, loosen the jam nuts at the terminations and loosen the threaded plugs a half turn until the head plate comes to rest on the weight plate below. Check that the threaded plugs are engaged at least 1/2" (12.7mm) at each termination.

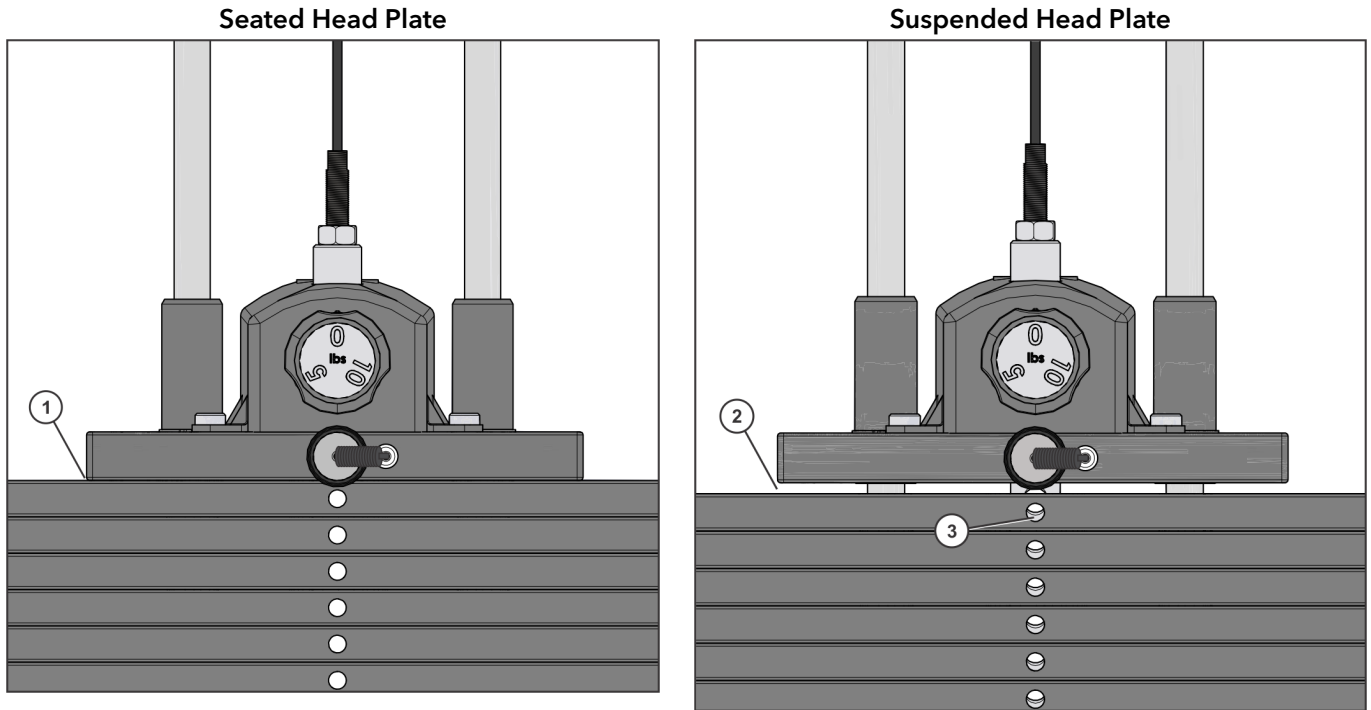

Item	Description
1	No Gap - Head plate is at rest
2	Gap - Head plate is lifted
3	Holes obstructed

2. Ensure that the weight stack selector pin can pin into each weight plate.
3. Tighten jam nuts to 20-25 ft-lbs.

Strength Cable Wear Guide

Replace cable at first sign of any of the following:

FRACTURES:

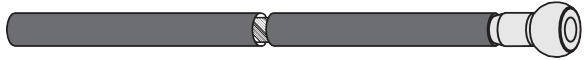
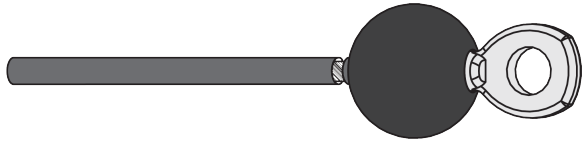
Casing can crack or fracture under strains during use. Any crack in the casing merits cable replacement even if no wire rope is exposed.	
Be especially observant for fractures near the components on the cable assembly - IE. Nylon Ball, Nico Loop, Threaded Plug, etc.	

TWISTING/BINDING:

Inspect casing to ensure wire rope is not twisting within its casing. Any sign of the cable twisting should be replaced immediately.	
--	--

BULGING:

Internal wire rope strands can break within and coil causing a bulge to appear. Cable should retain same outside diameter throughout.	
---	--

FRAYED/EXPOSED WIRE ROPE:

Any exposed wire rope protruding through the casing or at either end.	
---	--

FLATTENED:

Section of cable is compressed and will not retain its shape (outside diameter).	
--	--

PERMANENTLY BENT:

Cable has 'kink' and prohibits cable from laying straight. Wire rope may be unraveling beneath casing and is compromised warranting replacement.	
--	--

ENDS SEPARATING:

Watch for component end of cable to pull away from cable assembly - look for exposed wire rope.	
---	--

Insert Inspection

Inspect insert within the strain-relief cable end assembly and replace if any sign of damage.

1. Check around plastic insert and the plastic housing for any excessive wear or damage.

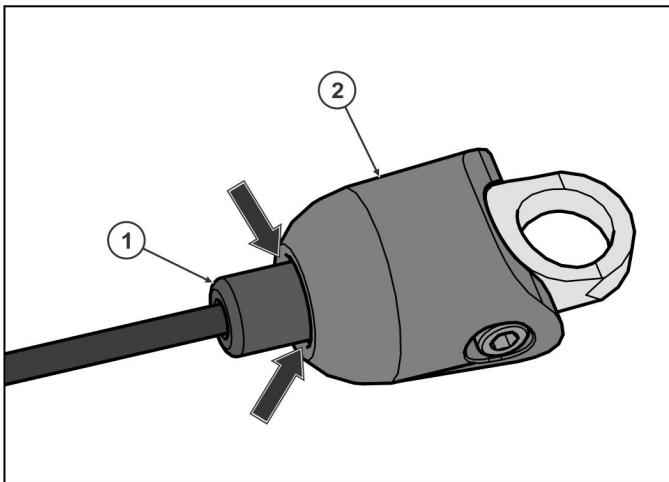

Item	Description	Qty.
1	Plastic Insert	1
2	Plastic Housing	1

2. Replace plastic insert if cracked, torn, separated, overly worn or damaged in any way.

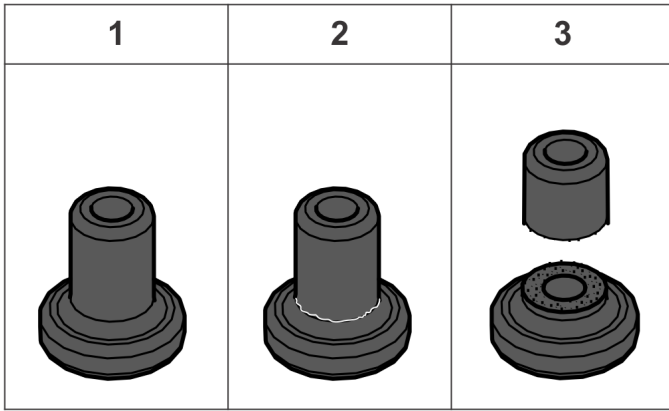

Item	Description	Status
1	Insert - No damage	Use
2	Insert - Cracked	Replace
3	Insert - Separated	Replace

3. Using a 4mm hex wrench, remove screws from the housing/link and the damaged insert from cable assembly. Replace damaged insert, reassemble components and **tighten to 8-10 in-lbs (0.9-1.1 Nm)**.

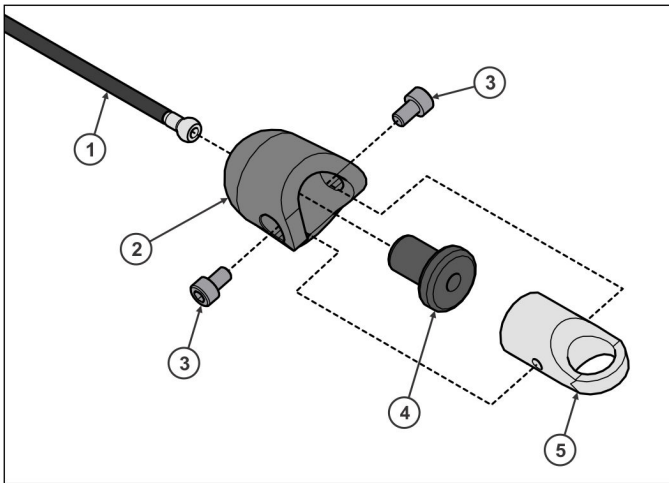

Item	Description	Qty.
1	Cable Assembly	1
2	Housing	1
3	Screw; M5 X 0.8 HXS SOC	2
4	Insert	1
5	Link	1

8. Bolt to Floor Guide

Introduction

Life Fitness designs its products to be stable when used as designed. Because strength training is dynamic, we cannot predict how users will ultimately use the products in all circumstances. Therefore, Life Fitness requires that strength training equipment be secured to a solid, level surface to stabilize and eliminate rocking or tipping over.

Each new unit shipped comes with a multi-language hangtag stating the importance of bolting the unit down as a safety precaution.

It is the facility's responsibility to adhere to local and regional building codes.

Bolt to Floor Qualifications

Unit	Recommended Bolt to Floor	Required Bolt to Floor
HDW-SQST Squat Stand	•	
HDW-HR Half Rack	•	
HDW-HR-STRD Half Rack	•	
HDW-PR Power Rack		•
HDW-PR-STRD Power Rack		•
HDW-PR Power Rack (with weight plate storage uprights)	•	
HDW-HHCR Half/Half Combo Rack		•
HDW-HHCR Half/Half Combo Rack (with stability feet)	•	
HDW-PHCR Power/Half Combo Rack		•
HDW-PHCR Power/Half Combo Rack (with stability feet)	•	
HDW-PPCR Power/Power Combo Rack	•	

IMPORTANT: If the rack is required to be bolted to the floor, the four outside points get the anchors. If there are stability feet, the feet get the anchors.

Delivery and Installation Tips

All Anchors

- Fasteners must have minimum embedment in concrete floor, not including screed, regardless of wood/tile/rubber over sub-floor. (See *Anchor Types* for maximum sub-floor thickness between unit and concrete to equipment foot must be made of flooring or other material (i.e. no air gaps)).
- DO NOT reuse fasteners. Static and Dynamic anchors are designed for one-time use only.
- Factor in equipment's feet height when selecting fastener length.
- Factor in flooring thickness when selecting fastener length.
- It is also recommended to drill an additional 1/2" (12.7 mm) of depth beyond the length of the fastener being used to ensure that debris does not block the entry of the anchor.
- Minimum concrete compressive strength: 3000 psi (20 N/mm²).

Anchoring

- All anchors must have a minimum embedment into concrete, regardless of wood/tile/rubber/screed over sub-floor.
- Dynamic anchors must have a minimum embedment depth in concrete to ensure maximum security and pull out force. See *Anchor Types* for embedment depth minimums.

Building Codes

It is the facility's responsibility to adhere to local and regional building codes. Please verify with the customer to ensure that they are aware of this.

Carpeting

If bolted down to carpet flooring, be sure to use a box cutter knife to cut the carpet threads around each foot. This will help avoid the carpet threads from being wrapped around and pulled by the drill bit.

Competitor Product

The bolt down guidelines and procedures for Life Fitness products were determined by the company's Engineering and Installation Development groups. These guidelines include which anchors to use and positioning of the anchors are required for Life Fitness product.

- Life Fitness does not have that level of specification or engineering input for competitive product.
- Life Fitness installation teams are not permitted to anchor competitor equipment.

Drilling

It is also recommended to drill an additional 1/2" (12.7 mm) of depth beyond the length of the fastener being used to ensure that debris does not block the entry of the anchor.

- This can be done by marking your drill bit with a piece of tape.
- While it is recommended that a vacuum be used to clean up debris, this will not account for all the debris that will settle at the bottom of the drilled hole.

Anchor Type - Static

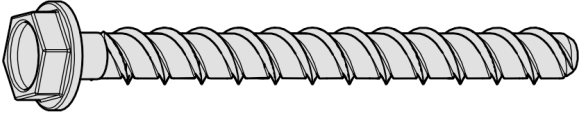
Static Anchor	Standard Sizes	Drill Bit Size
	Imperial: KH-EZ 3/8" x 5"	3/8in
	Metric: HUS-H 10mm x 130mm	10mm

Anchor Type - Dynamic

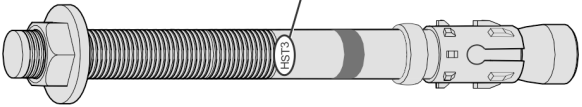
Dynamic Anchor	Standard Sizes	Drill Bit Size
	Imperial: KB-TZ2 3/8" x 5"	3/8in
	Metric: HST3 10mm x 130mm	10mm

Anchor Specifications

1	2	3	4	5	6
Dynamic Anchor	Minimum Concrete Thickness	Minimum Anchor Embedment into Concrete	Minimum Drill Depth in Concrete Beyond Anchor	Minimum Distance from Anchor to Concrete Edge or Seam:	Maximum Flooring (wood/tile/rubber/screed) Thickness Between Base Plate and Concrete
KB-TZ2 3/8" x 5"	4"	2-1/2"	1/2"	1-3/4"	0" - 0.92"
HST3 10mm x 130mm	100mm	68mm	12mm	44mm	0mm - 26mm

1	2	3	4	5	6
Static Anchor	Minimum Concrete Thickness	Minimum Anchor Embedment into Concrete	Minimum Drill Depth in Concrete Beyond Anchor	Minimum Distance from Anchor to Concrete Edge or Seam:	Maximum Flooring (wood/tile/rubber/screed) Thickness Between Base Plate and Concrete
KB-EZ 1/4"	4-1/8"	2-1/2"	1/2"	1-3/4"	0" - 0.92"
HUS-H 6mm	100mm	55mm	10mm	44mm	0mm - 26mm

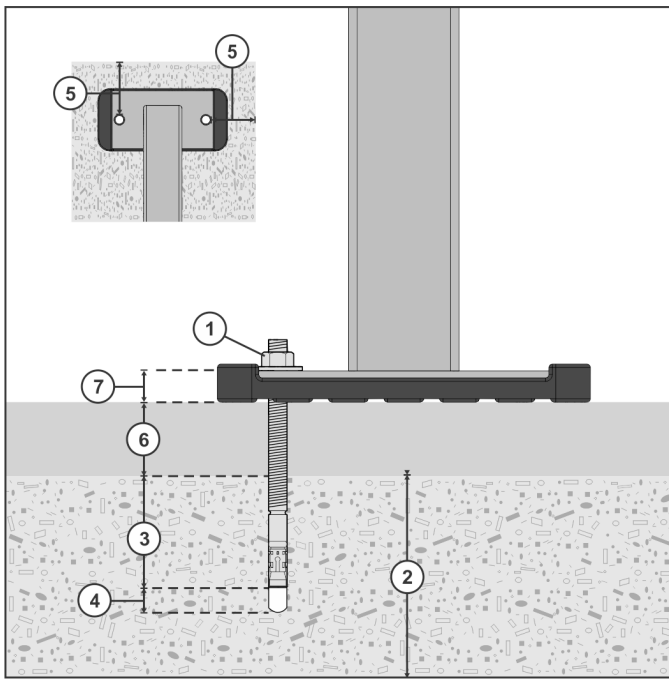

Item	Description
1	Anchor
2	Concrete Thickness
3	Anchor Embedment into Concrete Thickness
4	Drill Depth Beyond Anchor Thickness
5	Distance of Anchor to Concrete Edge
6	Flooring (wood/tile/rubber/screed) Thickness
7	Base Plate Thickness (See Foot Dimensions)

Pullout Force

Life Fitness specifies Hilti™ static and dynamic anchors. According to the anchor manufacturer, the recommended design pullout force (in tension) for the specified anchors, when properly installed in cracked concrete, is provided in the side table. This table should be used for reference only; for additional and up-to-date information on the anchor capabilities or the design pullout force in other substrates, please consult Hilti directly at <https://www.us.hilti.com>.

Dynamic Anchors	Design Resistance in Tension *
KB-TZ2 3/8" x 5" and HST3 10mm x 130mm	Greater than 2,000 lb (2.7kN)
Static Anchors	Design Resistance in Tension *
KH-EZ 1/4"	830 lb (3.6 kN)
HUS-H 6mm	3.3 kN (741lb)

* Design strength extracted from the Hilti™ Anchor Fastening Technology Manual.

Tools Required

⚠ WARNING: Adhere to manufacturer's equipment warnings and guidelines. Follow manufacturer's instructions for proper usage.

- 1" L-shape SDS rotary hammer
- (Imperial anchors) 3/8" diameter carbide drill bit
- (Metric anchors) 10mm diameter carbide drill bit
- Extension cord
- Floor scanner / rebar detector (optional)
- Hammer (Dynamic anchors only)
- Rotary tool
- Safety glasses
- Tape measure
- Torque wrench
- Vacuum (for debris)

Anchor Procedure

1. Place unit into position to be mounted and cycle unit to set its stance.
2. Wearing protective glasses, drill down into flooring perpendicularly to the required depth, ensuring that the foot thickness of the unit is being accounted for; refer to *Anchor Specifications* and *Foot Dimensions*.

NOTE: Use 3/8" size bit for Imperial anchors and 10mm for Metric anchors.

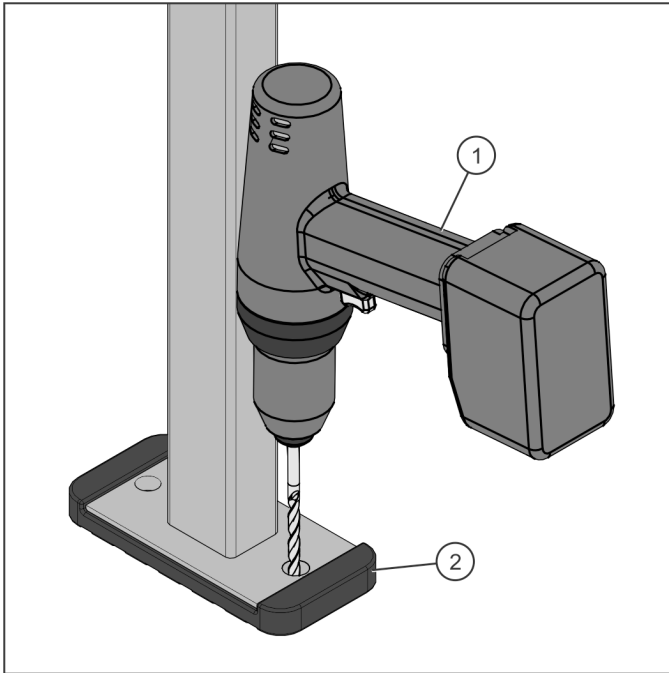

Item	Description	Qty.
1	Drill with Concrete Bit	1
2	Upright	1

3. Clear out debris from hole.
4. **NOTE:** This step only applies to dynamic anchors. Do not hammer static anchors.

Insert anchor assembly and hammer until flush against upright's base plate.

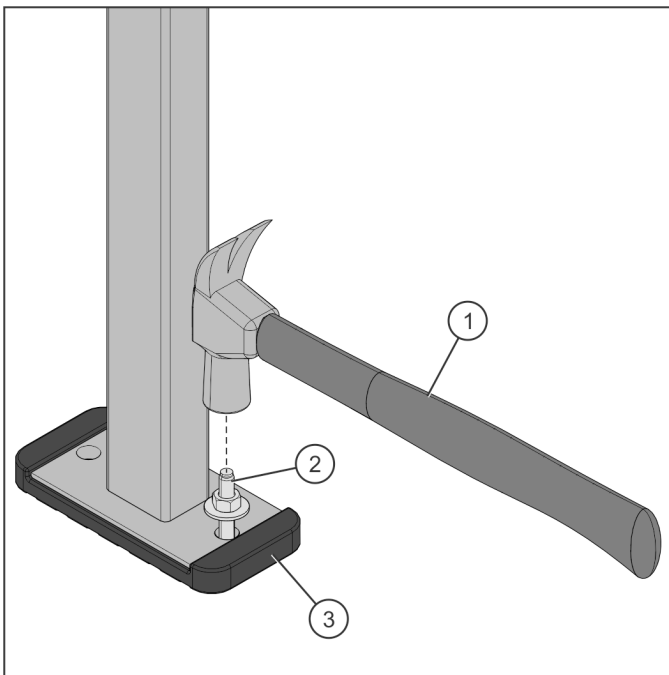

Item	Description	Qty.
1	Hammer	1
2	Anchor Assembly	1
3	Base Plate	1

5. Tighten to 30 foot-pounds for Imperial (45Nm for Metric), assuring there are at least 3 threads left exposed.

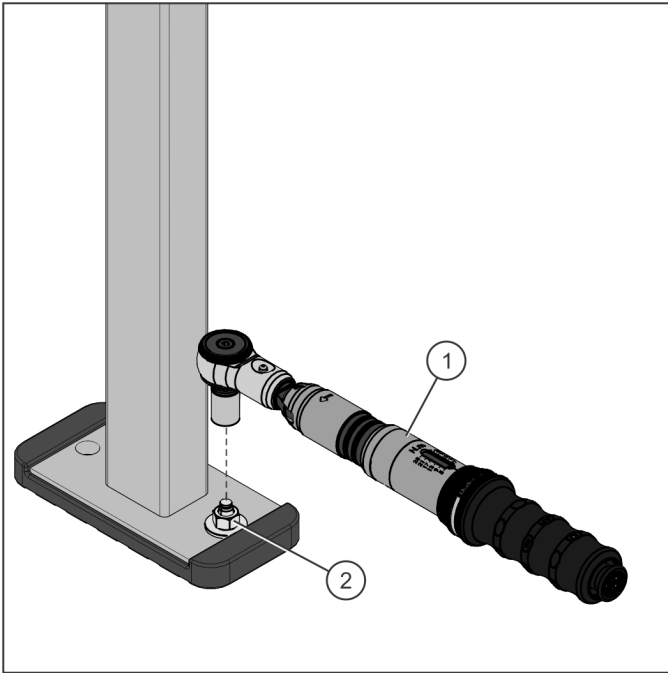

Item	Description	Qty.
1	Torque Wrench	1
2	Anchor Assembly	1

6. If necessary, cut extra length from top of anchor with a rotary tool leaving proper concrete engagement, torque requirements and at least 3 exposed threads.

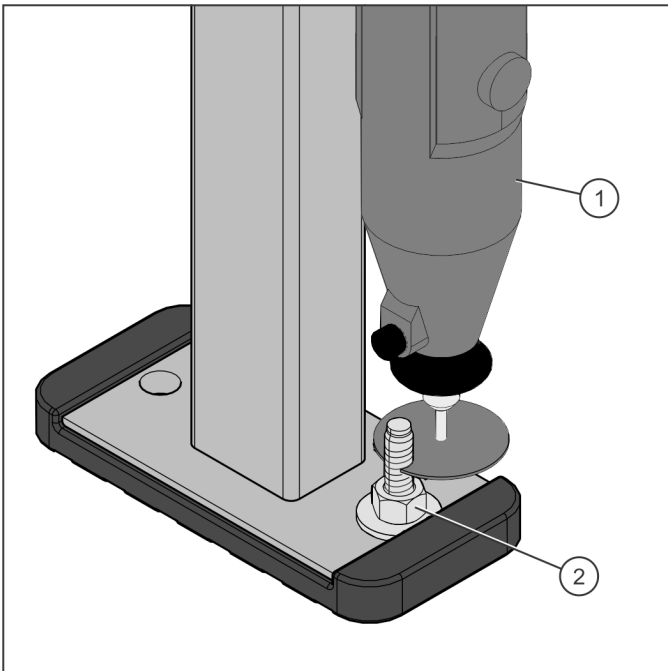

Item	Description	Qty.
1	Rotary Tool	1
2	Anchor Assembly	1

7. Check anchors weekly and re-tighten to 30 Foot-Pounds for Imperial (45Nm for Metric) if needed. Failure to do so may jeopardize anchor effectiveness.

Foot Dimensions

Use below image to determine foot height thickness.

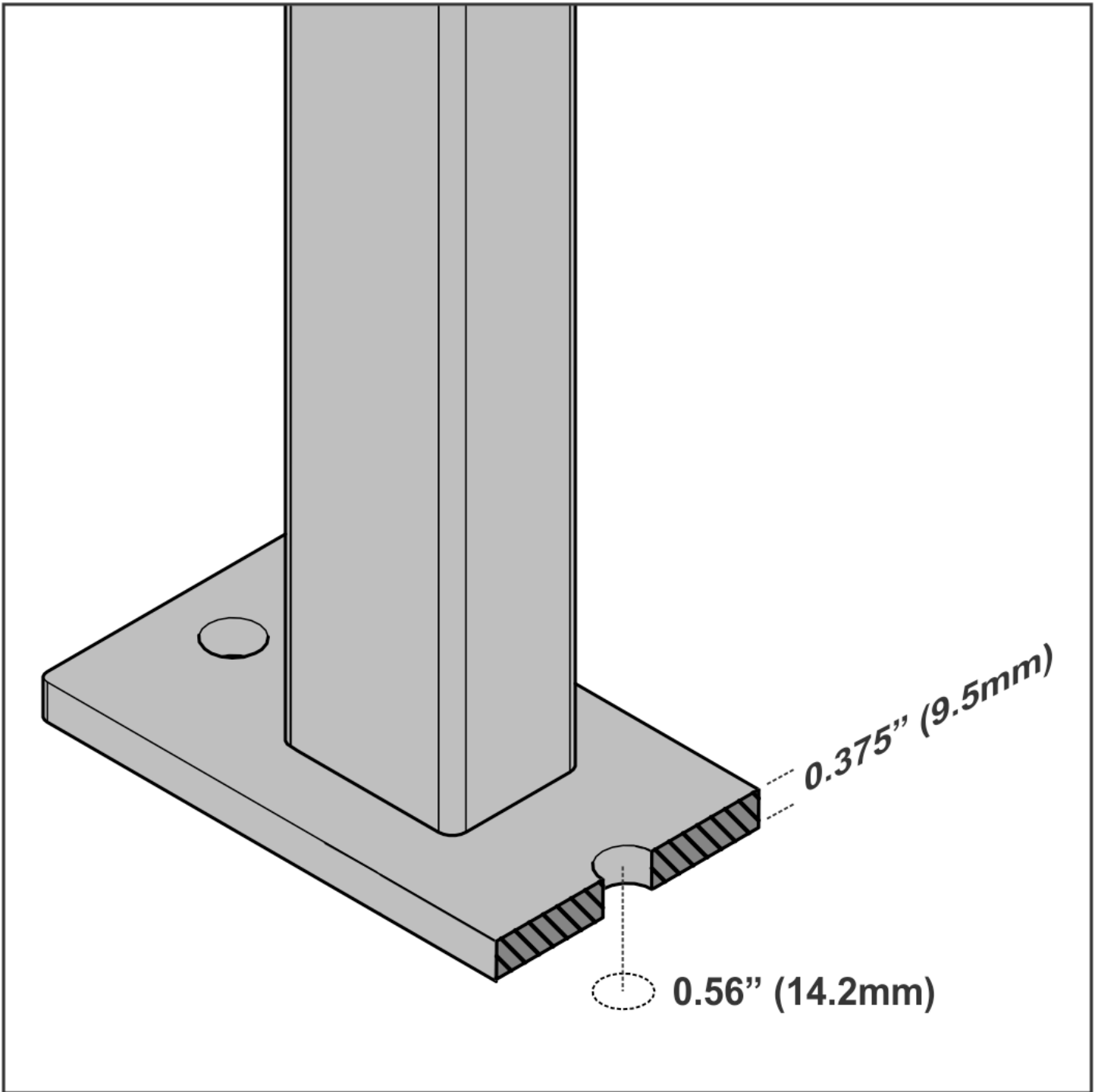

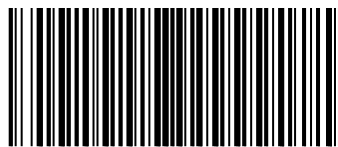

1020647-0001