

Optima Step

Owner's Manual

OSSTP

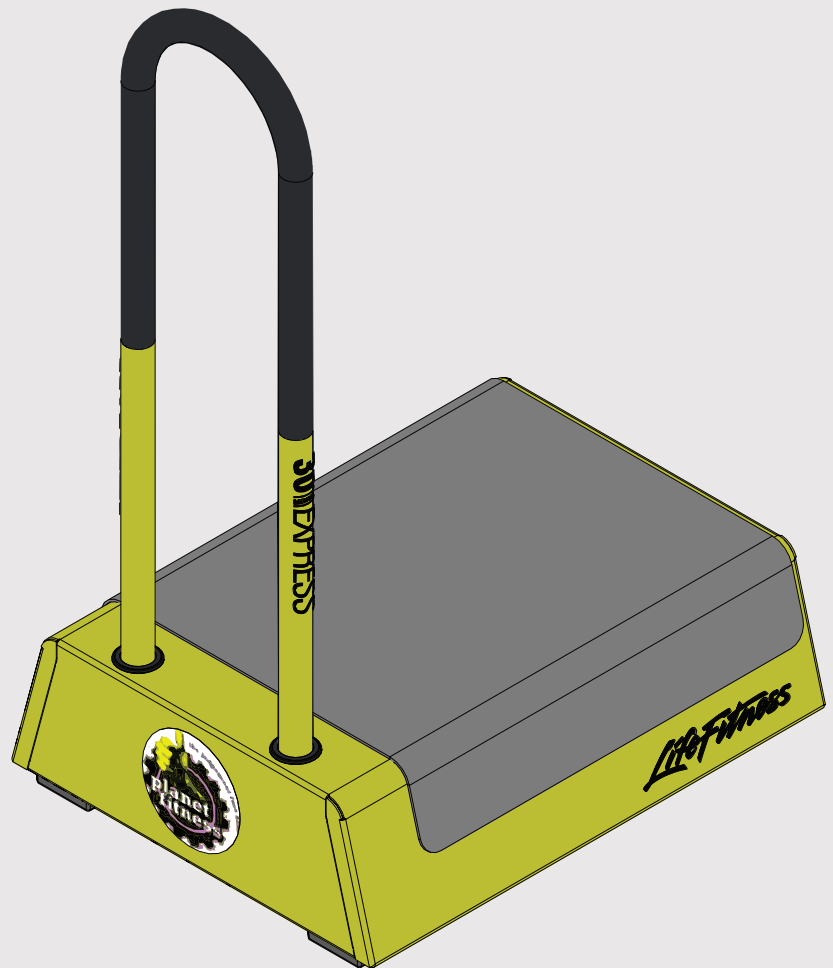

Life Fitness

M051-00K20-0426

Operation Manuals and other Product Information available at <https://www.lftechsupport.com/web/document-library/documents>

عقودملا ىلع عحاتم زاهجلا ن ع ىرخأ تامول عمو لي غشتلا ةلدأ <https://www.lftechsupport.com/web/document-library/documents>

操作マニュアルおよびその他の製品情報については、<https://www.lftechsupport.com/web/document-library/documents> をご覧ください。

如需操作手册和其他产品信息，请登录：<https://www.lftechsupport.com/web/document-library/documents>

操作手册和其他產品資訊請見 <https://www.lftechsupport.com/web/document-library/documents>

작동 설명서 및 기타 제품 정보는 <https://www.lftechsupport.com/web/document-library/documents> 에서 찾을 수 있습니다.

Trobareu el manual de funcionament i altra informació de producte a <https://www.lftechsupport.com/web/document-library/documents>

Mae Llwyfrau Gweithredu a Gwybodaeth Arall am Beiriannau ar gael yn <https://www.lftechsupport.com/web/document-library/documents>

Die Betriebsanleitung und andere Produktinformationen erhalten Sie unter <https://www.lftechsupport.com/web/document-library/documents>

Encontrará el manual de funcionamiento y otra información de producto en <https://www.lftechsupport.com/web/document-library/documents>

Erabiltzailearen Eskuliburua eta Beste Produktuei buruzko Informazioa eskuratu <https://www.lftechsupport.com/web/document-library/documents> gunean

Käyttöoppaat ja muut tuotetiedot ovat saatavana osoitteessa <https://www.lftechsupport.com/web/document-library/documents>

Les manuels d'utilisation, ainsi que d'autres informations sur les Produits, sont disponibles sur <https://www.lftechsupport.com/web/document-library/documents>

Felhasználói kézikönyvek és más termékinformációk: <https://www.lftechsupport.com/web/document-library/documents>

Manuali di funzionamento e altre informazioni sui prodotti disponibili su <https://www.lftechsupport.com/web/document-library/documents>

Manuali di funzionamento e altre informazioni sui prodotti disponibili su <https://www.lftechsupport.com/web/document-library/documents>

Instrukcje obsługi i inne informacje o produktach dostępne na stronie <https://www.lftechsupport.com/web/document-library/documents>

Manuais de Operação e Informações sobre outros produtos disponíveis em <https://www.lftechsupport.com/web/document-library/documents>

Руководства по эксплуатации и другую касающуюся нашей продукции информацию можно найти, перейдя по ссылке <https://www.lftechsupport.com/web/document-library/documents>

Kullanım Kılavuzları ve Diğer Ürün Bilgileri <https://www.lftechsupport.com/web/document-library/documents>'da bulunmaktadır

CORPORATE HEADQUARTERS

Columbia Centre III, 9525 West Bryn Mawr Avenue, Rosemont, Illinois 60018 • U.S.A.

847.288.3300 • FAX: 847.288.3703

Service phone number: 800.351.3737 (toll-free within U.S.A., Canada)

Global Website: www.lifefitness.com

INTERNATIONAL OFFICES

AMERICAS

North America Life Fitness, Inc.

Columbia Centre III
9525 West Bryn Mawr Avenue
Rosemont, IL 60018 U.S.A
Telephone: (847) 288 3300
Fax: (847) 288 3703
Service Email:
customersupport@lifefitness.com
Service Website: www.lifefitness.com/parts
Sales/Marketing Email:
commercialsales@lifefitness.com
Operating Hours: 7:00 am-6:00 pm (CST)

Brazil Life Fitness Brasil

Av Reboucas 2315
São Paulo, SP 05401-300
BRAZIL
SAC: 0800 773 8282
Telephone: +55 (11) 3095 5200
Fax: +55 (11) 3095 5201
Service Email: suporte@lifefitness.com.br
Sales/Marketing Email:
lifefitness@lifefitness.com.br
Service Operating Hours:
9:00 - 17:00 (BRT) (Monday-Friday)
Store Operating Hours:
9:00 -20:00 (BRT) (Monday-Friday)
10:00 - 16:00 (BRT) (Saturday)

Latin America & Caribbean* Life Fitness Inc.

Columbia Centre III
9525 West Bryn Mawr Avenue
Rosemont, IL 60018 U.S.A
Telephone: (847) 288 3300
Fax: (847) 288 3703
Service Email:
customersupport@lifefitness.com
Sales/Marketing Email:
commercialsales@lifefitness.com
Operating Hours: 7:00am-6:00pm (CST)

EUROPE, MIDDLE EAST, & AFRICA (EMEA)

Netherlands & Luxemburg Life Fitness Atlantic BV

Bijdorpplein 25-31
2992 LB Barendrecht
THE NETHERLANDS
Telephone: (+31) 180 646 666
Fax: (+31) 180 646 699
Service Email:
service.benelux@lifefitness.com
Sales/Marketing Email:
marketing.benelux@lifefitness.com
Operating Hours: 9.00h-17.00h (CET)

United Kingdom & Ireland Life Fitness UK LTD

Queen Adelaide
Ely, Cambs, CB7 4UB
Telephone: General Office (+44)
1353.666017
Customer Support (+44) 1353.665507
Fax: (+44) 1353.666018
Service Email: uk.support@lifefitness.com
Sales/Marketing Email: life@lifefitness.com
Operating Hours:
General Office: 9.00am - 5.00pm (GMT)
Customer Support: 8.30am - 5.00pm
(GMT)

Germany & Switzerland Life Fitness Europe GMBH

Siemensstraße 3
85716 Unterschleißheim
GERMANY
Telephone: (+49) 89.31 77 51.0 (Germany)
(+41) 0848 000 901 (Switzerland)
Fax: (+49) 89.31 77 51.99 (Germany)
(+41) 043 818 07 20 (Switzerland)
Service Email:
kundendienst@lifefitness.com
Sales/Marketing Email:
kundenberatung@lifefitness.com
Operating Hours: 08.30 -16.30h (CET)

Austria Life Fitness Austria

Vertriebs G.m.b.H.
Dückerstraße 7-9/3/36
1220 Vienna
AUSTRIA
Telephone: (+43) 1.61.57.198
Fax: (+43) 1.61.57.198.20
Service Email: kundendienst@lifefitness.com
Marketing/Sales Email:
kundenberatung@lifefitness.com
Operating Hours: 08:30-16.30.h (MEZ)

Spain Life Fitness IBERIA

C/Frederic Mompou 5,1^a
08960 Sant Just Desvern Barcelona
SPAIN
Telephone: (+34) 93.672.4660
Fax: (+34) 93.672.4670
Service Email: servicio.tecnico@lifefitness.com
Sales/Marketing Email:
info.iberia@lifefitness.com
Operating Hours:
9.00h-18.00h (Monday-Thursday)
8.30h-15.00h (Friday)

Belgium Life Fitness Benelux NV

Parc Industriel de Petit-Rechain
4800 Verviers
BELGIUM
Telephone: (+32) 87 300 942
Fax: (+32) 87 300 943
Service Email:
service.benelux@lifefitness.com
Sales/Marketing Email:
marketing.benelux@lifefitness.com
Operating Hours: 9.00h -17.00h (CET)

All Other EMEA Countries & Distributor Business C-EMEA*

Bijdorpplein 25-31
2992 LB Barendrecht
THE NETHERLANDS
Telephone: (+31) 180 646 644
Fax: (+31) 180 646 699
Service Email:
service.db.cemea@lifefitness.com
Sales/Marketing Email:
marketing.db.cemea@lifefitness.com
Operating Hours: 9.00h-17.00h (CET)

ASIA PACIFIC (AP)

Japan Life Fitness Japan

Japan Nippon Brunswick Bldg., #8F
5-27-7 Sendagaya
Shibuya-Ku, Tokyo
Japan 151-0051
Telephone: (+81) 3.3359.4309
Fax: (+81) 3.3359.4307
Service Email: service@lifefitnessjapan.com
Sales/Marketing Email:
sales@lifefitnessjapan.com
Operating Hours: 9.00h-17.00h (JAPAN)

Hong Kong Life Fitness Asia Pacific LTD

32/F, Global Trade Square
21 Wong Chuk Hang Road
HONG KONG
Telephone: (+852) 2575.6262
Fax: (+852) 2575.6894
Service Email:
HongKongEnquiry@lifefitness.com
Sales/Marketing Email:
Marketing.HK.Asia@lifefitness.com
Operating Hours: 9.00h-17.00h
Service Operating Hours: 9.00h-18.00h

All Other Asia Pacific countries & distributor business Asia Pacific* Life Fitness Asia Pacific LTD

32/F, Global Trade Square
21 Wong Chuk Hang Road
HONG KONG
Telephone: (+852) 2575.6262
Fax: (+852) 2575.6894
Service Email:
HongKongEnquiry@lifefitness.com
Sales/Marketing Email:
Marketing.HK.Asia@lifefitness.com
Operating Hours: 9.00h-17.00h
Service Operating Hours: 9.00h-18.00h

* Also check www.lifefitness.com for local representation or distributor/dealer

TABLE OF CONTENTS

Section	Description	Page
1.	Safety Information	3
2.	Warranty	5
3.	Contact Information	6
4.	Product Labels	7
5.	Assembly Instructions	8
6.	Bolt to Floor Guidelines	9

1 SAFETY INFORMATION

It is the sole responsibility of the purchaser of LIFE FITNESS products to read the owner's manual and warning labels and instruct all individuals, whether they are the end user or supervising personnel, on proper usage of the equipment.

UNDERSTANDING EACH AND EVERY WARNING TO THE FULLEST IS IMPORTANT. IF ANY OF THESE WARNINGS ARE UNCLEAR, CONTACT LIFE FITNESS CUSTOMER SERVICE IMMEDIATELY AT 1-800-735-3867.

This equipment is categorized as class S per EN 957-1. As such this equipment is only intended for commercial, institutional and/or studio facilities. It is not intended for home use. Contact LIFE FITNESS with any questions regarding this classification.

It is recommended that all users of LIFE FITNESS exercise equipment be informed of the following information prior to use.

ACCESS CONTROL

LIFE FITNESS recommends that all commercial fitness equipment be used in a supervised area. It is recommended that the equipment be located in an access controlled area. Control is the responsibility of the facility owner.

INSTALLATION/SECURING EQUIPMENT

LIFE FITNESS recommends that all equipment be secured to a solid, level surface to stabilize it and eliminate rocking or tipping over. This must be performed by a licensed contractor. Refer to the Bolt to Floor Guidelines within this manual for more information.

PROPER USAGE

1. Do not use any equipment in any way other than designed or intended by the manufacturer. It is imperative that LIFE FITNESS equipment is used properly to avoid injury.
2. Injuries may result if exercising improperly or excessively. It is recommended that all individuals consult a physician prior to commencing an exercise program. If at any time during exercise you feel faint, dizzy or experience pain, STOP EXERCISING and consult your physician.
3. Keep body parts (hands, feet, hair, etc.), clothing and jewelry away from moving parts to avoid injury.
4. When adjusting any seat, knee hold down pad, range of motion limiter, foothold pad, pulley or any other type of adjuster, make certain that the adjusting pin is fully engaged in the hole to avoid injury.
5. Health and environmental regulations warning - this product may contain chemicals known to the state of California to cause cancer, birth defects, or other reproductive harm. For more information related to the European Commission regulation (ec) no. 1907/2006 (Reach) and the California safe drinking water and toxic Enforcement act of 1986 (proposition 65), please visit <https://www.Lftechsupport.Com/web/guest/environmentalregulations-Information>.

INSPECTION

1. DO NOT use or permit use of any equipment that is damaged and/or has worn or broken parts. For all LIFE FITNESS equipment use only replacement parts supplied by LIFE FITNESS.
2. Cables and belts pose an extreme liability if used when frayed. Always replace any cable at first sign of wear (consult LIFE FITNESS if uncertain).
3. Routinely inspect all accessory clips that join attachments to the cables and replace them at the first sign of wear.
4. MAINTAIN LABELS AND NAME PLATES - Do not remove labels for any reason. They contain important information. If unreadable or missing, contact LIFE FITNESS for a replacement.

INSPECTION (CONTINUED)

5. EQUIPMENT MAINTENANCE - Preventative maintenance is the key to smooth operating equipment as well as to keep your liability to a minimum. Equipment needs to be inspected at regular intervals.
6. Ensure that any person(s) making adjustments or performing maintenance or repair of any kind is qualified to do so. LIFE FITNESS will provide service and maintenance training at our corporate facility upon request or in the field if proper arrangements are made.
7. Before any use, examine all accessories approved for use with the LIFE FITNESS equipment for damage or wear.
8. DO NOT ATTEMPT TO USE OR REPAIR ANY ACCESSORY APPROVED FOR USE WITH THE LIFE FITNESS EQUIPMENT WHICH APPEARS TO BE DAMAGED OR WORN.

OPERATING WARNINGS

1. It is the purchaser's sole responsibility to properly instruct its end users and supervising personnel as to the proper operating procedures of all LIFE FITNESS equipment.
2. Keep children away from strength equipment. Parents or others supervising children must provide close supervision of children if the equipment is used in the presence of children.
3. Do not allow users to wear loose fitting clothing or jewelry while using equipment. It is also recommended to have users secure long hair back and up to avoid contact with moving parts.
4. All bystanders must stay clear of all users, moving parts and attached accessories and components while machine is in operation.

PLATE LOADED, FREE WEIGHT AND BODY WEIGHT SYSTEMS

1. If the unit is equipped with weight rods, use only Olympic style weight plates (2.0" bore) for training weight. Do not use dumbbells or any means other than those stated to increase weight resistance - See machine specific section for more information.
2. Always utilize weight plate retention devices such as clamps or pins.
3. Only add weight plates up to the load limits of the unit. Make sure all weight plates are completely placed on the weight rod.
4. Never exceed the load rating for any plate loaded station, body weight station, bench or other free weight device; including specific weight rod and band peg limits. See machine specific section for load limit information.
5. Contact a Life Fitness representative with any questions regarding proper weights and loading.

SELECTORIZED WEIGHT STACK SYSTEMS

1. Use only weight selector pins supplied by LIFE FITNESS on weight stacks. Substitutes are forbidden.
2. Fully insert weight selector pins. Partial insertion can cause weights to fall unexpectedly.
3. Never pin the weight stack in an elevated position.
4. Never remove selector pin if any weights are suspended.
5. Never attempt to release jammed weights or parts.
6. Never use dumbbells or other means to incrementally increase the weight resistance. Use only those means provided by LIFE FITNESS.

2 WARRANTY

WHAT IS COVERED

This Life Fitness commercial exercise equipment (.Product.) is warranted to be free of all defects in material and workmanship.

WHO IS COVERED

The original purchaser or any person receiving the product as a gift from the original purchaser.

WHO PAYS TRANSPORTATION & INSURANCE FOR SERVICE

If the Product or any covered part must be returned to a service facility for repairs, We, Life Fitness, will pay all transportation and insurance charges for the first year. You are responsible for transportation and insurance charge after the first year.

WHAT WE WILL DO TO CORRECT COVERED DEFECTS

We will ship to you any new or rebuilt replacement part or component, or at our option, replace the Product. Such replacement parts are warranted for the remaining portion of the original warranty period.

WHAT IS NOT COVERED

Any failures or damage caused by unauthorized service, misuse, accident, negligence, improper assembly or installation, debris resulting from any construction activities in the Product's environment, rust or corrosion as a result of the Product's location, alterations or modifications without our written authorization, or by failure on your part to use, operate and maintain the Product as set out in you Operation Manual (.Manual.).

All terms of this warranty are void if this product is moved beyond the continental borders of the United States of America (excluding Alaska, Hawaii and Canada) and are then subject to the terms provided by that country's local authorized Life Fitness representative.

OPERATION MANUAL

It is VERY IMPORTANT THAT YOU READ THIS MANUAL before operating the Product. Remember to perform the periodic maintenance requirements specified in the Manual to assure proper operation and your continued satisfaction.

EXCLUSIVE WARRANTY

THIS LIMITED WARRANTY IS IN LIEU OF ALL OTHER WARRANTIES OF ANY KIND EITHER EXPRESSED OR IMPLIED, INCLUDING BUT NOT LIMITED TO THE IMPLIED WARRANTIES OF MERCHANTABILITY AND FITNESS FOR A PARTICULAR PURPOSE, AND ALL OTHER OBLIGATIONS OR LIABILITIES ON OUR PART. We neither assume nor authorize any person to assure for us any other obligation or liability concerning the sale of this Product. Under no circumstances shall we be liable under this warranty, or otherwise, of any damage to any person or property, including any lost profits or lost savings, for any special, indirect, secondary, incidental or consequential damages of any nature arising out of the use of or inability to use this Product. Some states do not allow the exclusion or limitation of implied warranties or of liability for incidental or consequential damages, so the above limitations or exclusions may not apply to you.

CHANGES IN WARRANTY NOT AUTHORIZED

No one is authorized to change, modify or extend the terms of this limited warranty.

EFFECTS OF STATE LAWS

This warranty gives you specific legal rights, and you may have other rights which vary from state to state and country by country.

OUR PLEDGE TO YOU

We want you to be completely satisfied with our Products and will do everything possible under the terms of this warranty to keep you secure in knowing you have bought the best!

HOW TO OBTAIN PARTS & SERVICE

1. Verify the symptom and review the operating instructions. The problem may be unfamiliarity with the product and its features and workouts.
2. Locate and write down the serial number of the unit.
3. Contact the nearest Life Fitness Customer Support Services Group.

WARRANTY COVERAGE

* *There is no warranty coverage for labor on Strength Products.*

Frame	Grips	Hardware / Mechanical
1 Year	90 Days	90 Days

3 CONTACT INFORMATION

For Product Service within the United States and Canada:

Toll-free: 800-735-3867

Please call Monday through Friday from 7:00 a.m. to 6:00 p.m. Central Standard Time, and tell them your name, address, and serial number of your Product. They will tell you how to get a replacement part, or if necessary, arrange for service where your Product is located or advise you on how and where to ship the Product for service. Before shipping:

1. Obtain a Return Authorization Number (RA#) from Customer Support Services.
2. Securely pack your Product (use the original shipping carton, if possible).
3. Write the RA# on the outside of the carton.
4. Insure the Product.
5. Include a letter explaining the defect or problem and a copy of your proof of purchase if you believe the service is covered by warranty.

Return address:

Life Fitness World Headquarters
Attn: CSS Help Desk
Columbia Centre III
9525 West Bryn Mawr Ave.
Rosemont, IL 60018

For Product Service Internationally see contact information listed on page one of this manual.

4 PRODUCT LABELS

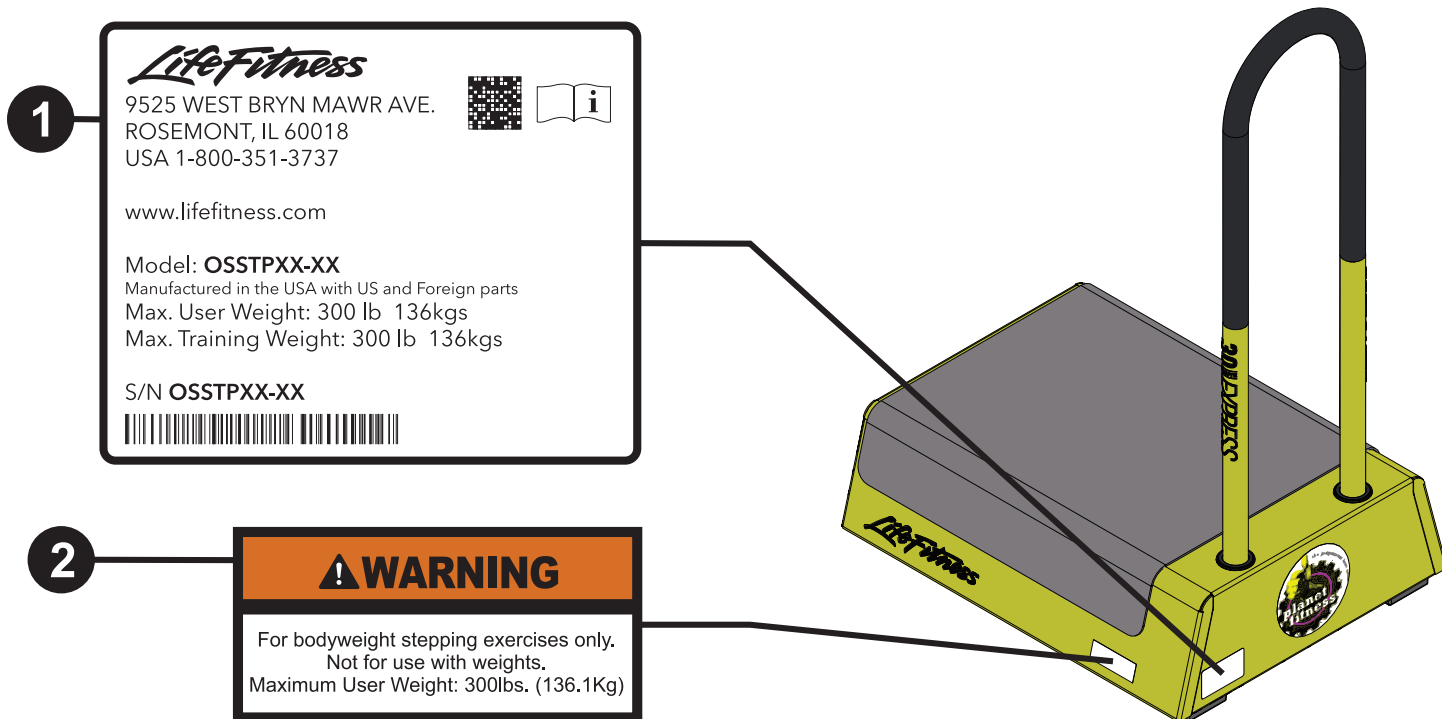



ITEM NO.	DESCRIPTION	QTY.
1	Serial Number	1
2	Step Warning	1

5 ASSEMBLY INSTRUCTIONS

TOOLS REQUIRED:

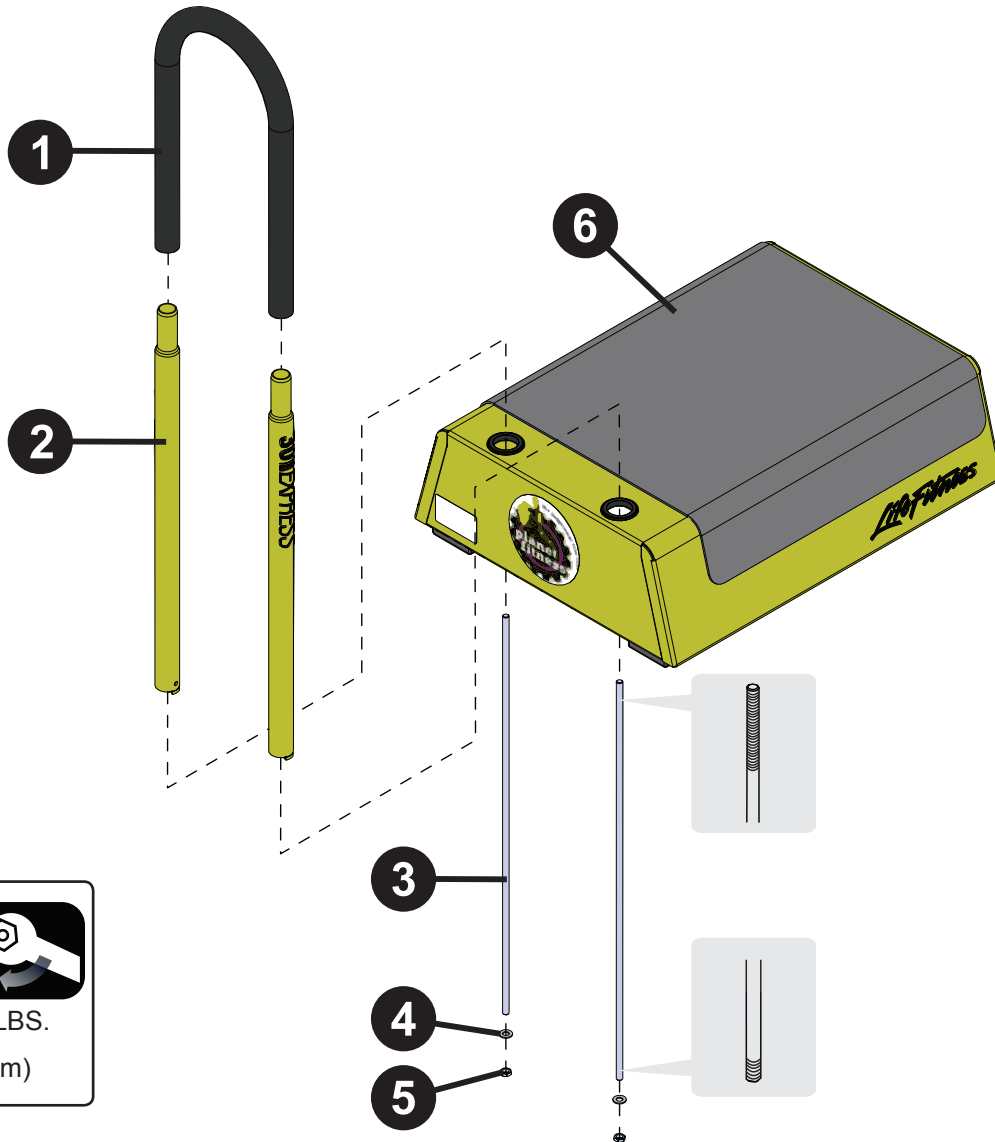
- 17mm Box End Wrench



100% 

20-25 FT-LBS.
(27-33 Nm)

ITEM NO.	DESCRIPTION	QTY.
1	Handle	2
2	Tube Handle	2
3	Threaded Rod	2
4	Washer	2
5	Nut	2
6	Base	1

6 BOLT TO FLOOR GUIDELINES

Introduction

LIFE FITNESS designs its products to be stable when used as designed. Because strength training is dynamic, we cannot predict how users will ultimately use the products in all circumstances. Therefore, LIFE FITNESS **recommends** that the strength training equipment listed below be secured to a solid, level surface to stabilize and eliminate rocking or tipping over.

- Optima Step (OSSTP)

It is the facility's responsibility to adhere to local and regional building codes.

ALL ANCHORS:

- Fasteners must have minimum embedment in concrete floor, not including screed, regardless of wood/tile/rubber over subfloor. (See Anchor Types for maximum subfloor thickness between unit and concrete to equipment foot must be made of flooring or other material (i.e. no air gaps)).
- DO NOT reuse fasteners. Static and Dynamic anchors are designed for one-time use only.
- Factor in equipment's feet height when selecting fastener length.
- Factor in flooring thickness when selecting fastener length.
- It is also recommended to drill an additional 1/2" (12.7mm) of depth beyond the length of the fastener being used to ensure that debris does not block the entry of the anchor.
- Minimum concrete compressive strength: 3000psi (20 N/mm²).

Anchoring

- All anchors must have a minimum embedment into concrete, regardless of wood/tile/rubber/screed over sub-floor.
- Dynamic anchors must have a minimum embedment depth in concrete to ensure maximum security and pull out force. See Anchor Specification for embedment depth minimums.

Building Codes

- It is the facility's responsibility to adhere to local and regional building codes. Please verify with the customer to ensure that they are aware of this.

Carpeting

- If bolted down to carpet flooring, be sure to use a box cutter knife to cut the carpet threads around each foot. This will help avoid the carpet threads from being wrapped around and pulled by the drill bit.

Competitor Product

- The bolt down guidelines and procedures for LIFE FITNESS products were determined by the company's Engineering and Installation Development groups. These guidelines include which anchors to use and positioning of the anchors are required for Life Fitness product.
 1. LIFE FITNESS does not have that level of specification or engineering input for competitive product.
 2. LIFE FITNESS installation teams are not permitted to anchor competitor equipment.

Drilling

- It is also recommended to drill an additional 1/2" (12.7mm) of depth beyond the length of the fastener being used to ensure that debris does not block the entry of the anchor.
 1. This can be done by marking your drill bit with a piece of tape.
 2. While it is recommended that a vacuum be used to clean up debris, this will not account for all the debris that will settle at the bottom of the drilled hole.

Anchor Types

PRODUCT	ANCHOR		Subfloor between unit and concrete 0" to 1/2" (12.7mm) thick	Subfloor between unit and concrete over 1/2" (12.7mm) thick
Optima Step (OSSTP)	Dynamic	Imperial	HST M 12 x 115/20 to 295/200 (length depends on subfloor thickness)	
		Metric		

Anchor Specifications

DYNAMIC ANCHOR	Minimum Concrete Thickness	Minimum Drill Depth in Concrete	Minimum Concrete Embedment	Minimum concrete compressive strength
HST M 12	140mm (5-1/2")	10mm beyond anchor length	70mm (2.8")	20 N/mm ²

Pullout Force

LIFE FITNESS specifies Hilti™ static and dynamic anchors. According to the anchor manufacturer, the recommended design pullout force (in tension) for the specified anchors, when properly installed in cracked concrete, is provided in the side table. This table should be used for reference only; for additional and up-to-date information on the anchor capabilities or the design pullout force in other substrates, please consult Hilti directly at <https://www.us.hilti.com>.

SELECTED ANCHOR	DESIGN RESISTANCE IN TENSION
HST M12 x 115/20	8 kN
HST M12 x 195/200	8 kN
* Design strength extracted from the Hilti Anchor Fastening Technology Manual issued September 2014.	

Tools Required

Adhere to manufacturer's equipment warnings and guidelines. Follow manufacturer's instructions for proper usage.

Floor scanner/rebar detector (optional)	Safety glasses
1" L-shape SDS rotary hammer	Extension cord
Dead blow hammer	Impact wrench
1/2" x 12" (12mm x 305mm) carbide drill bit (for 1/2" (12mm) anchors)	Vacuum (for debris)

Dynamic Anchor Procedure: HST M12

If it is possible that the length of your bolt will not provide the minimum requirement of 2.5" (63.5mm) of engagement, a longer anchor should be used.

1. Place unit into position to be mounted. Mark two points 25.16" (639mm) apart at the desired position.
2. Remove existing hex nut from anchor and replace with provided clamping nut.
3. If necessary, cut HST Safety Stud Anchor to length before installation, leaving enough length to ensure proper concrete embedment (See Minimum Concrete Thickness).
4. Wearing protective glasses, drill down into the flooring to the required depth as perpendicular as possible, ensuring that the foot thickness is being accounted for; refer to Anchor Selection and Foot Dimensions.
5. Clear debris from hole and area.
6. Insert fastener and tighten to 44 Foot-Pounds (60Nm).
7. If necessary, cut extra length from top of the anchor with a rotary tool leaving proper concrete engagement and torque requirements.
8. Place Optima Step keyholes over anchors and slide forward to smaller section of keyhole.
9. Retighten anchor to 44 Foot-Pounds (60Nm).

