

Life Fitness Benches and Racks

LBR-AB, LBR-AC, LBR-AD, LBR-AR, LBR-BB, LBR-BC, LBR-BE, LBR-BR, LBR-D2, LBR-DB, LBR-DF, LBR-DL, LBR-DS, LBR-DV, LBR-DX, LBR-FB, LBR-FS, LBR-LC, LBR-LD, LBR-LR, LBR-MA, LBR-MB, LBR-OD, LBR-OF, LBR-OI, LBR-OM, LBR-OS, LBR-OT, LBR-OW, LBR-UB

Owner's Manual



Corporate Headquarters

Columbia Centre III, 9525 Bryn Mawr Avenue, Rosemont, IL 60018 • U.S.A.
847.288.3300 • FAX: 847.288.3703
Service phone number: 800.351.3737 (toll-free within U.S.A., Canada)
Global Website: www.lifefitness.com

International Offices

AMERICAS

North America

Life Fitness, LLC

Columbia Centre III
9525 Bryn Mawr Avenue
Rosemont, IL 60018 U.S.A.
Telephone: (847) 288 3300
Service Email:
customersupport@lifefitness.com
Sales/Marketing Email:
commercialsales@lifefitness.com

Brazil

Life Fitness Brasil

Av. Rebouças, 2315
Pinheiros
São Paulo, SP 05401-300
BRAZIL
SAC: 0800 773 8282 option 2
Telephone: +55 (11) 3095 5200 option 2
Service Email: suportebr@lifefitness.com
Sales/Marketing Email:
vendasbr@lifefitness.com

Latin America and Caribbean*

Life Fitness, LLC

Columbia Centre III
9525 Bryn Mawr Avenue
Rosemont, IL 60018 U.S.A.
Telephone: (847) 288 3300
Service Email:
customersupport@lifefitness.com
Sales/Marketing Email:
commercialsales@lifefitness.com

EUROPE, MIDDLE EAST, and AFRICA (EMEA)

Belgium, Netherlands, and Luxemburg

Life Fitness (Atlantic) B.V.

Fascinatio Boulevard 230, 4th Fl - Bldg B
3065WB, Rotterdam
The Netherlands
+31 88 646 6666
Service Email:
service.benelux@lifefitness.com
Sales/Marketing Email:
marketing.benelux@lifefitness.com

United Kingdom

Life Fitness UK LTD

Unit 109^a
Lancaster Way Business Park
Ely, Cambs, CB6 3NX
Telephone: General Office (+44)
1353.666017
Customer Support (+44) 1353.665507
Service Email: uk.support@lifefitness.com
Sales/Marketing Email: life@lifefitness.com

Germany, Austria, and Switzerland

Life Fitness Europe GMBH

Neuhofweg 9
85716 Unterschleißheim
GERMANY
Telephone:
+49 (0) 89 / 31775166 Germany
+43 (0) 1 / 6157198 Austria
+41 (0) 848 / 000901 Switzerland
Service Email:
kundendienst@lifefitness.com
Sales/Marketing Email:
vertrieb@lifefitness.com

Spain

Life Fitness IBERIA

C/Frederic Mompou 5,1^o^a
08960 Sant Just Desvern Barcelona
SPAIN
Telephone: (+34) 93.672.4660
Service Email:
servicio.tecnico@lifefitness.com
Sales/Marketing Email:
info.iberia@lifefitness.com

All Other EMEA Countries and Distributor Business EMEA*

Life Fitness (Atlantic) B.V.

Fascinatio Boulevard 230, 4th Fl - Bldg B
3065WB, Rotterdam
The Netherlands
+31 88 646 6666
Service Email:
emeaservicesupport@lifefitness.com

ASIA PACIFIC (AP)

Japan

Life Fitness Japan, Ltd

4-17-33 Minami Aoyama 1F/B1F
Minato-ku - Tokyo 107-0062
Japan
Telephone: (+81) 0120.114.482
Fax: (+81) 03-5770-5059
Service Email: service.lfj@lifefitness.com
Sales/Marketing Email:
sales@lifefitnessjapan.com

Hong Kong

Life Fitness Asia Pacific LTD

26/F, Global Trade Square
21 Wong Chuk Hang Road
Wong Chuk Hang
Hong Kong
Telephone: (+852) 25756262
Fax: (+852) 25756894
Service Email: service.hk@lifefitness.com
Sales/Marketing Email:
marketing.hk.asia@lifefitness.com

All Other Asia Pacific countries and distributor business Asia Pacific*

Life Fitness Asia Pacific LTD

26/F, Global Trade Square
21 Wong Chuk Hang Road
Wong Chuk Hang
Hong Kong
Telephone: (+852) 25756262
Fax: (+852) 25756894
Service Email: service.ap@lifefitness.com
Sales/Marketing Email:
marketing.hk.asia@lifefitness.com

*Also check www.lifefitness.com for local representation or distributor/dealer

User and Service Documents Link

<https://fn.fit/KnowledgeBase>

<https://fn.fit/PartStore>

Additional information is available online using the links above.

تتوفر معلومات إضافية على الإنترنت باستخدام الرابط أعلاه.

点击上面的链接可在线获取更多信息。

Flere oplysninger er tilgængelige online gennem linket ovenfor.

Bijkomende informatie is online beschikbaar via bovenstaande link.

Vous trouverez plus d'informations en ligne à l'aide du lien ci-dessus.

Zusätzliche Informationen finden Sie online über den oben angegebenen Link.

Ulteriori informazioni sono disponibili online utilizzando il link sopra riportato.

追加情報は上記リンクを使用してオンラインで利用可能です。

상기 링크를 통해 온라인에서 추가 정보를 볼 수 있습니다.

Informações adicionais estão disponíveis on-line, através do link acima.

Дополнительная информация доступна в интернете по ссылке, указанной выше.

Mediante el enlace anterior podrá acceder a información adicional en línea.

Ytterligare information finns online genom att använda länken ovan.

İnternet üzerinden daha fazla bilgi edinmek için yukarıdaki bağlantıyı kullanabilirsiniz.

هناك معلومات إضافية متاحة على الإنترنت باستخدام الرابط أعلاه.

Informazio osagarria eskuragarri dago goiko estekaren bidez.

Допълнителна информация можете да намерите онлайн, като използвате връзката по-горе.

Mitjançant l'enllaç anterior podreu accedir a informació addicional en línia.

使用上面的連結線上提供額外資訊。

Dodatne informacije možete pronaći na internetu sljedeći vezu iznad.

ከላይ የተመጠውን አገናኝ(ሊንክ) በመጠቀም መረጃዎች አንላይን ያገኛሉ።

Lisätietoja on saatavissa verkosta käyttämällä yllä olevaa linkkiä.

Wubetumi anya nsem afoforo aka ho wo websait so denam asem a ewo atifi ho a wubemia so so.

Πρόσθετες πληροφορίες είναι διαθέσιμες online χρησιμοποιώντας το σύνδεσμο παραπάνω.

מידע נוסף אפשר לקבל באינטרנט באמצעות הקישור לעיל.

További információ elérhető online, a fenti hivatkozás segítségével.

Viðbótarupplýsingar eru fáanlegar á netinu með því að smella á tengilinn hér fyrir ofan.

Plus indicium per superum situm potes invenire.

മുകളിലുള്ള ലിങ്ക് ഉപയോഗിച്ച് ഓൺലൈനിൽ കൂടുതൽ വിവരങ്ങൾ ലഭ്യമാണ്.

Ytterligere informasjon er tilgjengelig på nettet via linken ovenfor.

Dodatkowe informacje są dostępne online pod powyższym odnośnikiem.

Informações adicionais estão disponíveis online a usar o link acima.

Informații suplimentare sunt disponibile online, utilizând link-ul de mai sus.

Dodatne informacije dostupne su na mreži putem gornjeg linka.

Ďalšie informácie sú dostupné online na vyššie uvedenom odkaze.

Table of Contents

Safety

Safety Information.....	6
Product Labels.....	8

Product Information

Benches.....	28
Racks.....	46

Maintenance Procedures

Maintenance Schedule.....	58
---------------------------	----

Warranty

What is Covered.....	59
Who is Covered.....	59
Who Pays Transportation and Insurance For Service.....	59
What We Will Do To Correct Covered Defects.....	59
What is Not Covered.....	59
Owner's Manual.....	59
Exclusive Warranty.....	59
Changes in Warranty Not Authorized.....	59
Effects of State Laws.....	59
Terms of Warranty Coverage.....	59

Life Fitness® is a registered trademark.

Gym Wipes® is a registered trademark of the 2XL Corporation. PureGreen 24 is a trademark of Pure Green.

© Copyright 2026, Life Fitness, LLC. All Rights Reserved. Life Fitness, Hammer Strength, Cybex, ICG and SCIFIT are registered trademarks of Life Fitness, LLC and its affiliated companies and subsidiaries. Disclaimer: Images and specifications are current as of the date of publication and are subject to change.

Columbia Center III - 9525 Bryn Mawr Ave., Rosemont, IL 60018 • 847-288-3300 •

www.lifefitness.com • 1022961-0001 AB • 2026

1. Safety

Safety Information

It is the sole responsibility of the purchaser of Life Fitness products to read the owner's manual and warning labels and instruct all individuals, whether they are the end user or supervising personnel, on proper usage of the equipment.

UNDERSTANDING EACH AND EVERY WARNING TO THE FULLEST IS IMPORTANT. IF ANY OF THESE WARNINGS ARE UNCLEAR, CONTACT Life Fitness CUSTOMER SERVICE IMMEDIATELY AT 1-800-351-3737.

This equipment is categorized as class S per EN ISO 20957-1. As such this equipment is only intended for commercial, institutional and/or studio facilities. It is not intended for home use. Contact Life Fitness with any questions regarding this classification.

It is recommended that all users of Life Fitness exercise equipment be informed of the following information prior to use.

Operating Warnings

⚠ WARNING: This product can expose you to chemicals including 1,3 Butadiene, which is known to the State of California to cause cancer and birth defects or other reproductive harm. For more information go to <http://www.P65Warnings.ca.gov>

- Life Fitness does not warrant nor guarantee that component parts used in the manufacture of products offered under the Life Fitness brand are latex-free. Users of these products must take all necessary precautions to prevent accidental contact that could lead to an adverse latex reaction.
- It is the purchaser's sole responsibility to properly instruct its end users and supervising personnel as to the proper operating procedures of all equipment.
- This equipment is not intended for use by children. Keep children under the age of 14 away from the machine.
- Do not allow users to wear loose fitting clothing or jewelry while using equipment. It is also recommended to have users secure long hair back and up to avoid contact with moving parts.
- All bystanders must stay clear of all users, moving parts and attached accessories and components while machine is in operation.

Access Control

- Life Fitness recommends that all commercial fitness equipment be used in a supervised area. It is recommended that the equipment be located in an access controlled area. Control is the responsibility of the facility owner.

Installation

- Life Fitness recommends that all equipment be secured to a solid, level surface to stabilize it and eliminate rocking or tipping over. This must be performed by a licensed contractor. See [Bolt to Floor Guide](#) for installation procedure.

Proper Usage

- Do not use any equipment in any way other than as designed or intended by the manufacturer. It is imperative that Life Fitness equipment is used properly to avoid injury.
- Injuries may result if exercising improperly or excessively. It is recommended that all individuals consult a physician prior to commencing an exercise program. If at any time during exercise you feel faint, dizzy or experience pain, STOP EXERCISING and consult your physician.

Inspection

- DO NOT attempt to use or repair any accessory approved for use with the equipment which appears to be damaged or worn.
- DO NOT use or permit use of any equipment that is damaged and/or has worn or broken parts. For all Life Fitness equipment, use only replacement parts supplied by Life Fitness.
- Maintain labels, name plates and instructional placards. Do not remove labels or instructional placards for any reason. They contain important information. Contact Customer Support to replace any worn, damaged, or unreadable labels or instructional placards and to ensure that you are always using the latest version of labels and instructional placards.
- Equipment Maintenance - Preventative maintenance is the key to smooth operating equipment as well as to keep your liability to a minimum. Equipment needs to be inspected at regular intervals.
- Ensure that any person(s) making adjustments or performing maintenance or repair of any kind is qualified to do so. Life Fitness will provide service and maintenance training at our corporate facility upon request or in the field if proper arrangements are made.
- Before use, examine all accessories approved for use with the Life Fitness equipment for damage or wear.

Plate Loaded, Free Weight, and Body Weight Systems

- Never exceed the load rating for any plate loaded station, body weight station, bench or other free weight device; including specific weight rod and band peg limits. See machine specifications for load limit information.
- Contact a Life Fitness representative with any questions regarding proper weights and loading.

Warnings and Cautions

- Warning labels indicate a potentially hazardous situation that could result in serious injury or death if the precautions are not observed.
- Caution labels indicate a potentially hazardous situation that could result in serious injury or damage to machine if the precautions are not observed.
- Contact [Customer Support Services](#) to replace any worn, damaged, or unreadable labels and to ensure that you are always using the latest version of labels.

Product Labels

150 lb Max. Dumbbell Rack



Do Not Sit



Serial Number

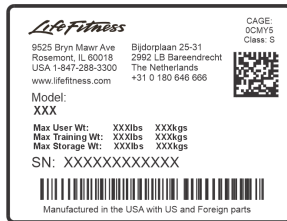

FCC Compliant

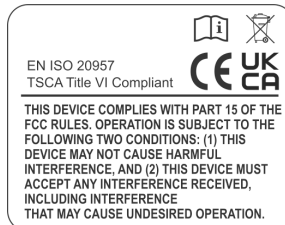

Pinch Hazard



OLY General Warning

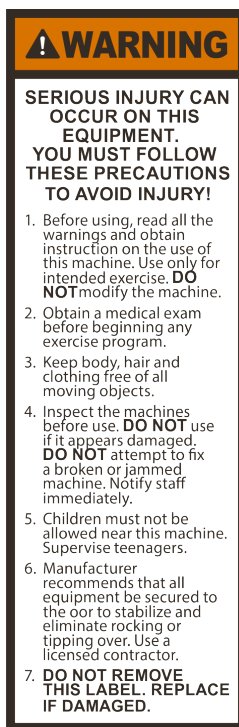

General Warning

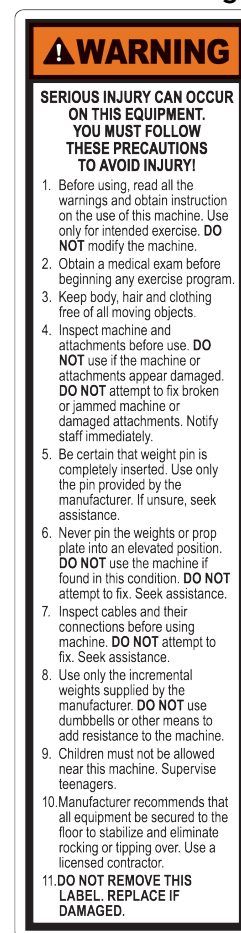

General Warning

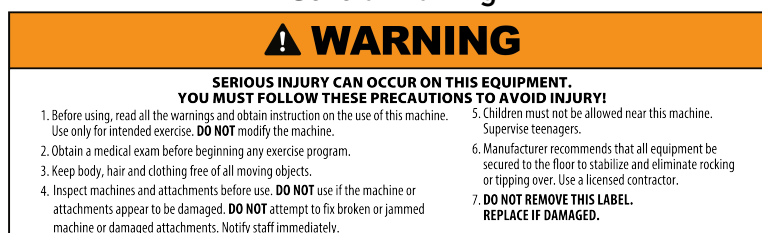

Benches

Abdominal Crunch Bench (LBR-AC)

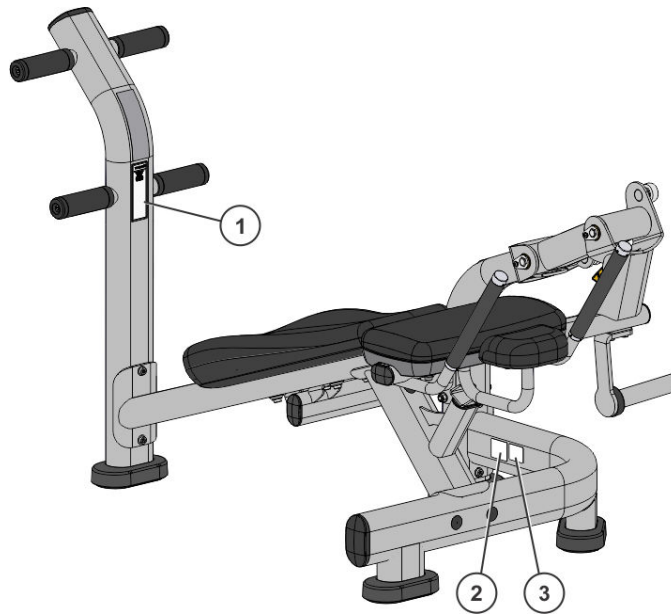

Item	Description	Qty.
1	General Warning	1
2	FCC Compliant	1
3	Serial Number	1

Ab Bench (LBR-AB)

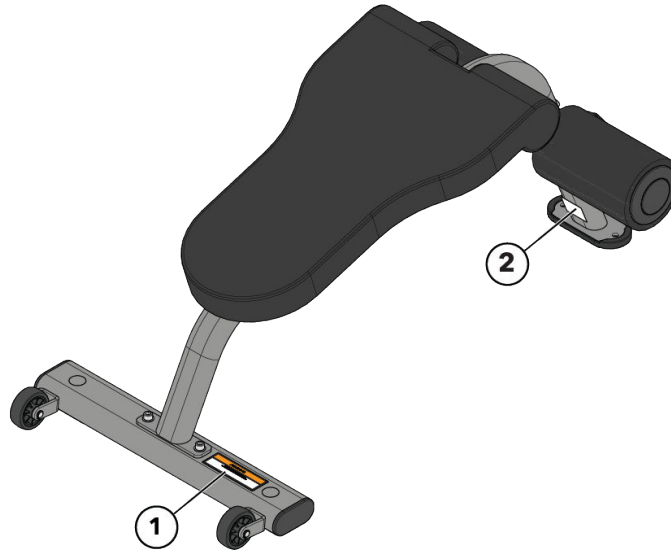

Item	Description	Qty.
1	General Warning	1
2	Serial Number	1

Adjustable Bench (LBR-AD)

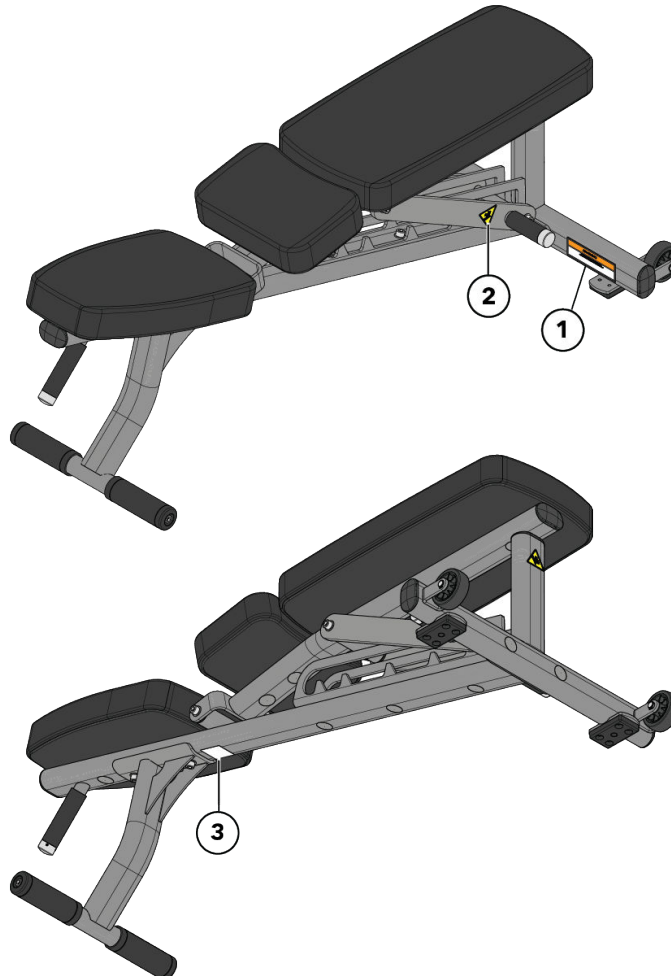

Item	Description	Qty.
1	General Warning	1

Item	Description	Qty.
2	Pinch Hazard	3
3	Serial Number	1

Biceps Curl Bench (LBR-BC)

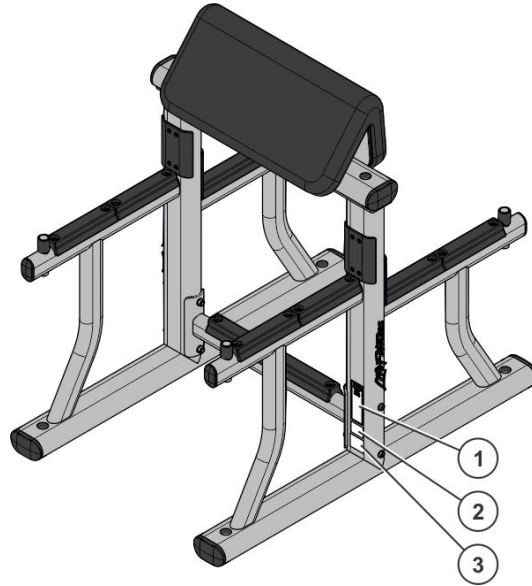

Item	Description	Qty.
1	General Warning	1
2	FCC Compliant	1
3	Serial Number	1

Back Extension (LBR-BE)

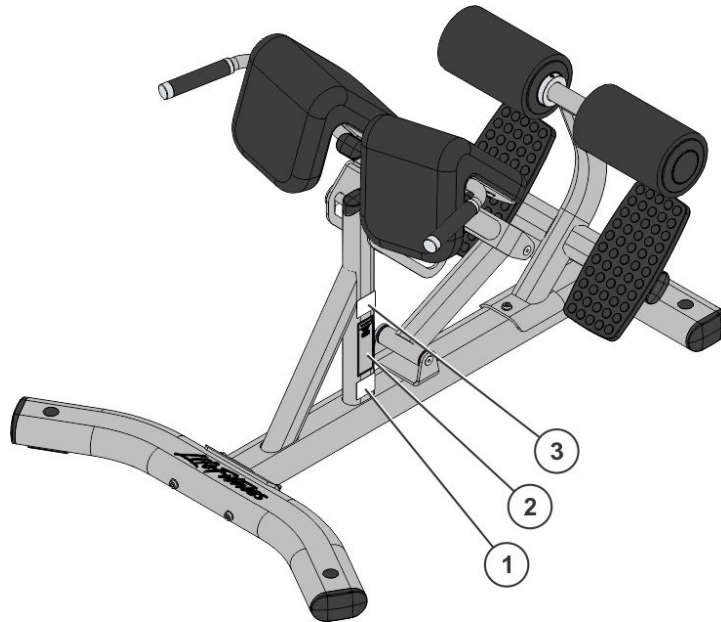

Item	Description	Qty.
1	Serial Number	1
2	General Warning	1
3	FCC Compliant	1

Decline Bench (LBR-DB)

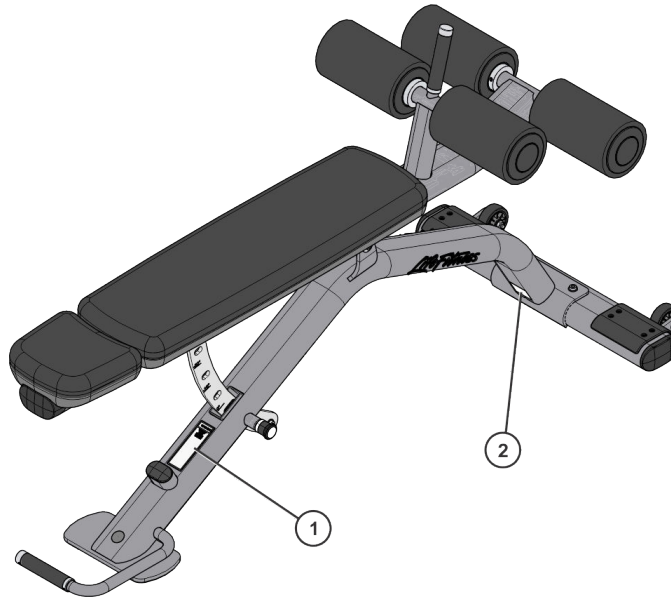

Item	Description	Qty.
1	General Warning	1
2	Serial Number	1

Dip Leg Raise (LBR-LD)



Item	Description	Qty.
1	General Warning	1

Item	Description	Qty.
2	Serial Number	1

Flat Bench (LBR-FB)

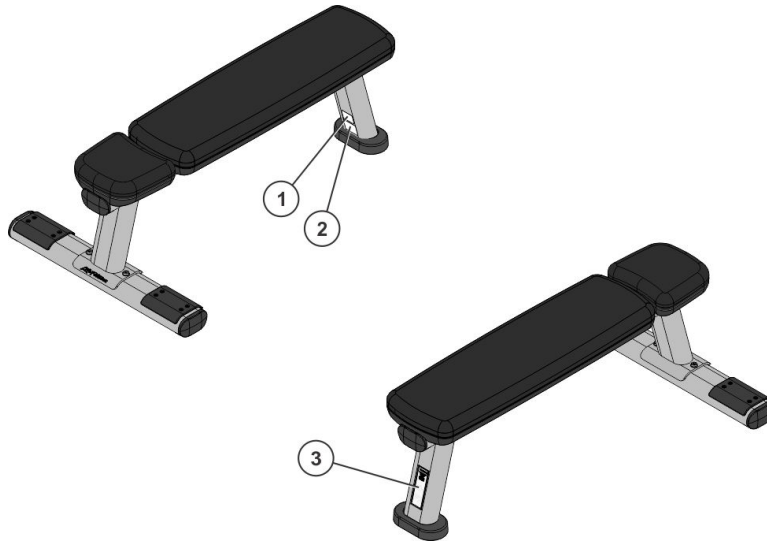

Item	Description	Qty.
1	FCC Compliant	1
2	Serial Number	1
3	General Warning	1

Flexibility Stretch (LBR-FS)



Item	Description	Qty.
1	General Warning	1

Item	Description	Qty.
2	Pinch Hazard	1
3	Serial Number	1
4	Do Not Sit	1
5	Placard	1

Leg Raise/Dip/Chin (LBR-LC)

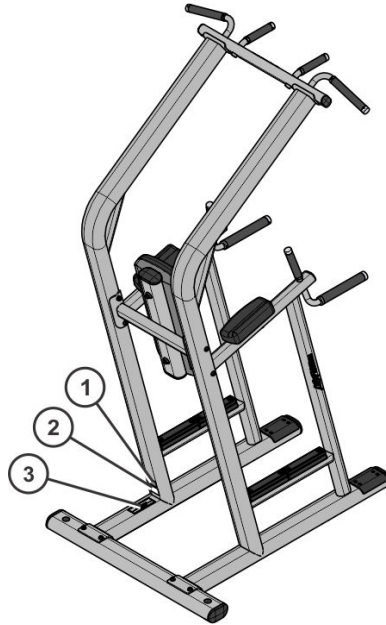

Item	Description	Qty.
1	FCC Compliant	1
2	Serial Number	1
3	General Warning	1

Leg Raise (LBR-LR)

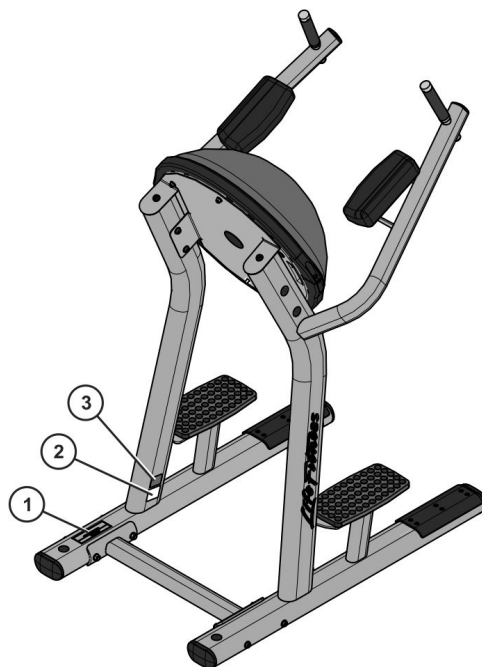

Item	Description	Qty.
1	General Warning	1
2	Serial Number	1
3	FCC Compliant	1

Multi-Adjustable Bench (LBR-MA)

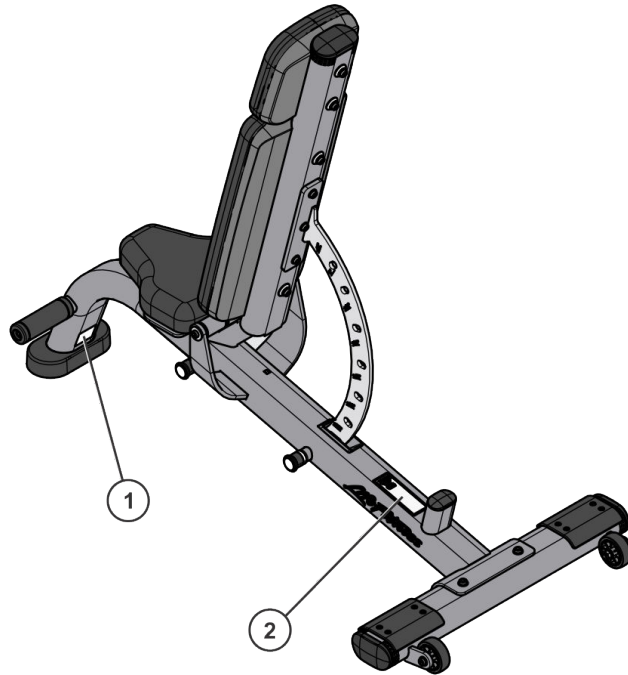

Item	Description	Qty.
1	Serial Number	1
2	General Warning	1

Olympic Decline Bench (LBR-OD)



Item	Description	Qty.
1	General Warning	1
2	FCC Compliant	1
3	Serial Number	1

Olympic Flat Bench (LBR-OF)

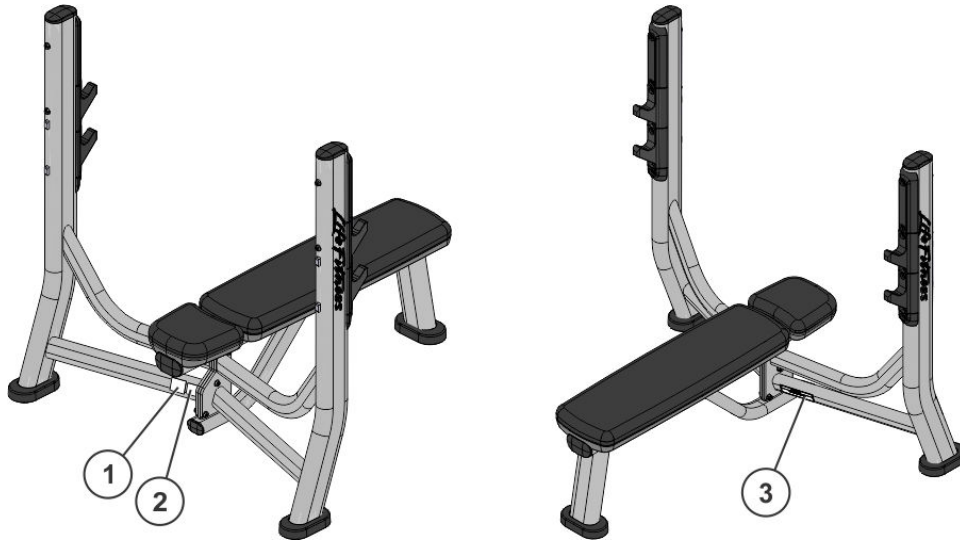

Item	Description	Qty.
1	Serial Number	1
2	FCC Compliant	1
3	General Warning	1

Olympic Incline Bench (LBR-OI)

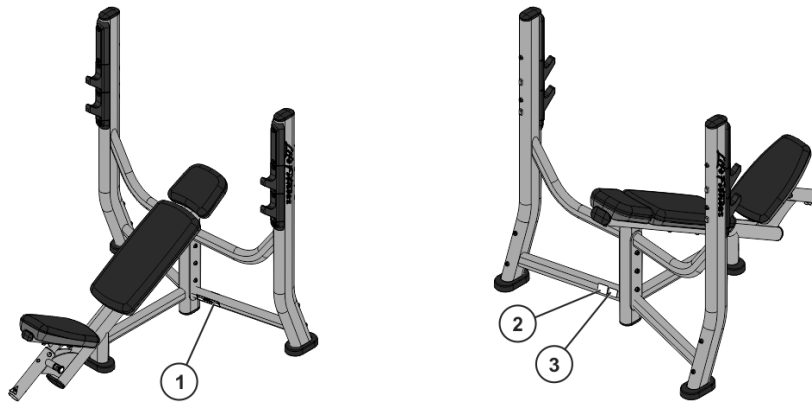

Item	Description	Qty.
1	General Warning	1
2	FCC Compliant	1
3	Serial Number	1

Olympic Military Bench (LBR-OM)

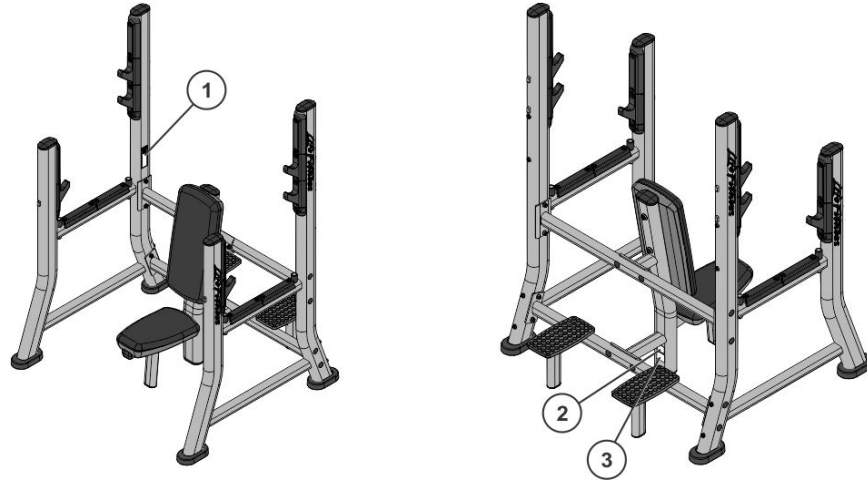

Item	Description	Qty.
1	General Warning	1
2	FCC Compliant	1
3	Serial Number	1

Olympic Bench Weight Storage (LBR-OW)

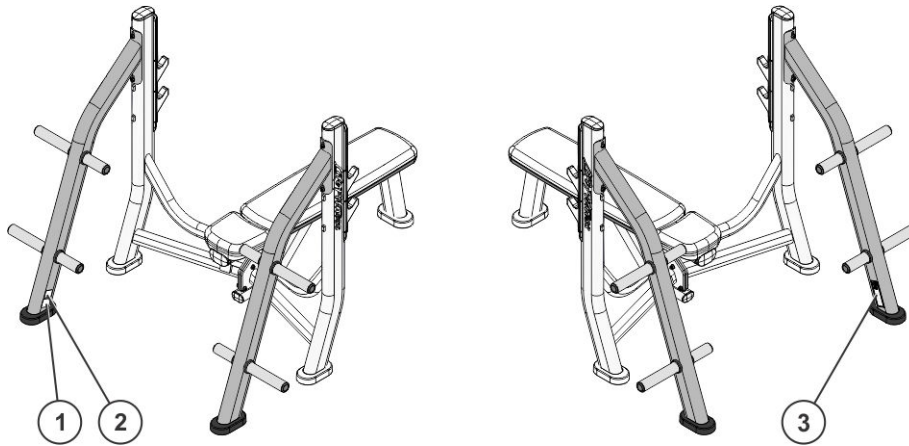

Item	Description	Qty.
1	FCC Compliant	1
2	Serial Number	1
3	General Warning	1

Utility Bench (LBR-UB)

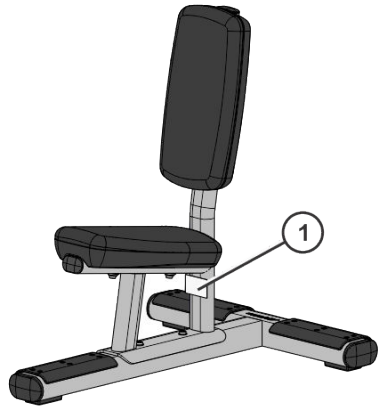

Item	Description	Qty.
1	FCC Compliant	1
2	General Warning	1
3	Serial Number	1

Racks

Accessory Rack (LBR-AR)

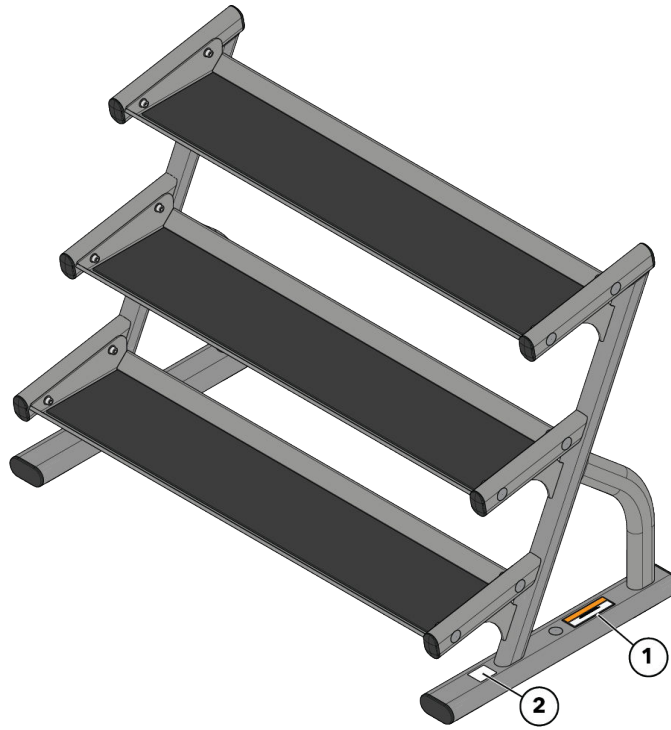

Item	Description	Qty.
1	Serial Number	1
2	General Warning	1

Barbell Rack (LBR-BB)

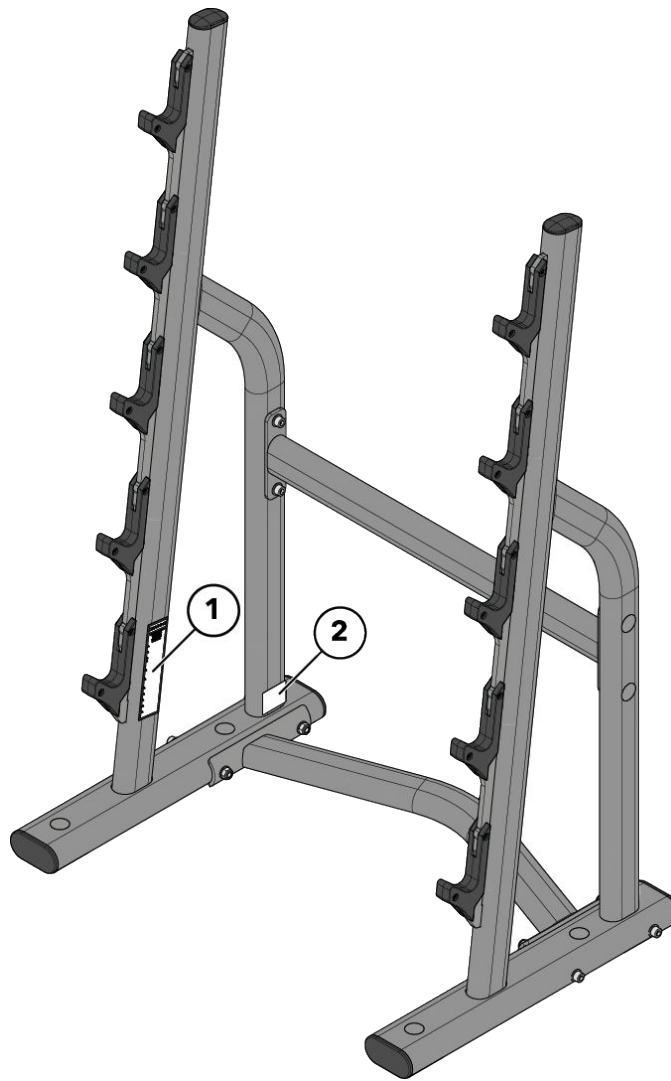

Item	Description	Qty.
1	General Warning	1
2	Serial Number	1

Barbell Rack (LBR-BR)

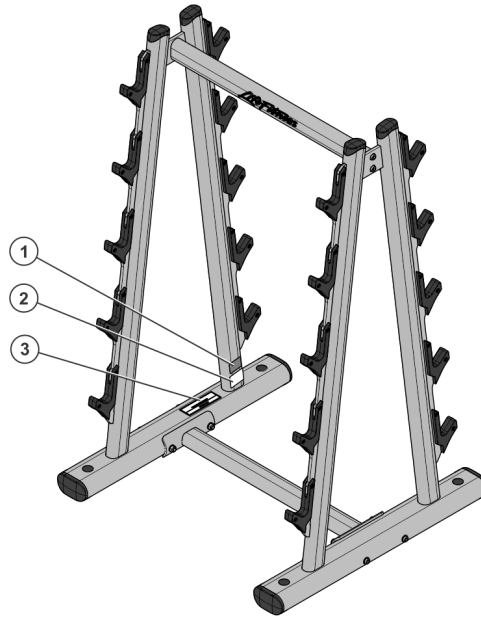

Item	Description	Qty.
1	FCC Compliant	1
2	Serial Number	1
3	General Warning	1

Dumbbell Rack (LBR-DL)

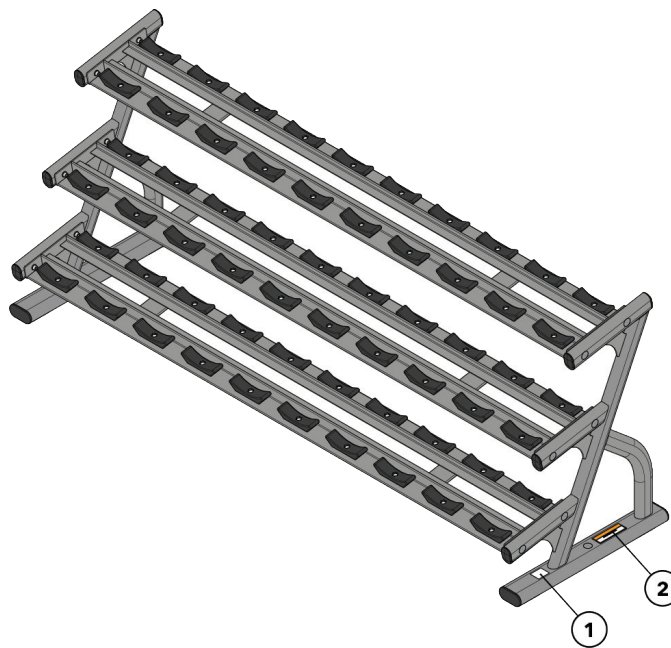

Item	Description	Qty.
1	Serial Number	1
2	General Warning	1

Dumbbell Rack (LBR-DS)

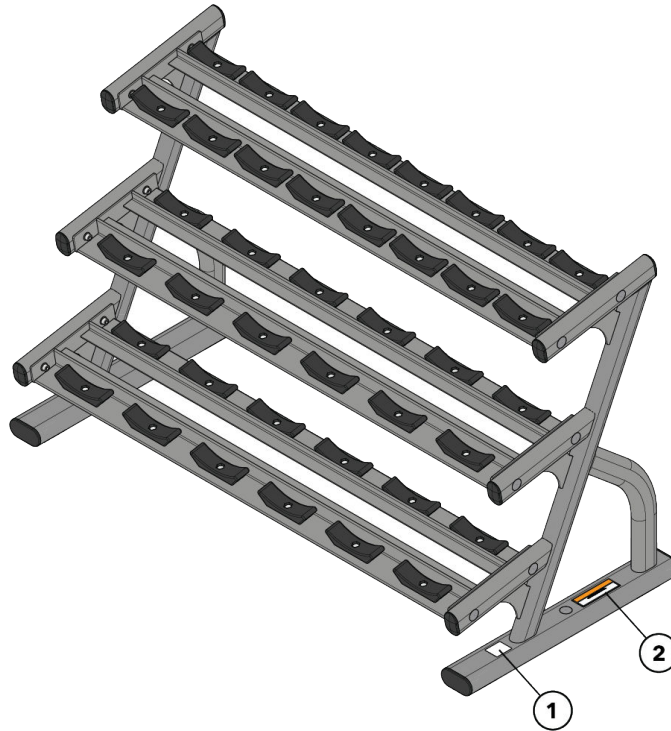

Item	Description	Qty.
1	Serial Number	1
2	General Warning	1

Hex Dumbbell Rack (LBR-DF)

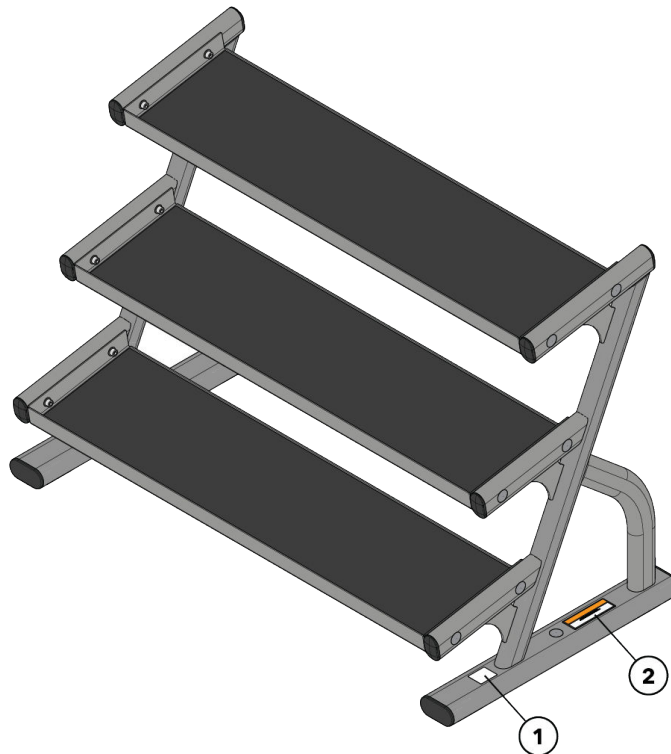

Item	Description	Qty.
1	Serial Number	1
2	General Warning	1

Medicine Ball Storage (LBR-MB)

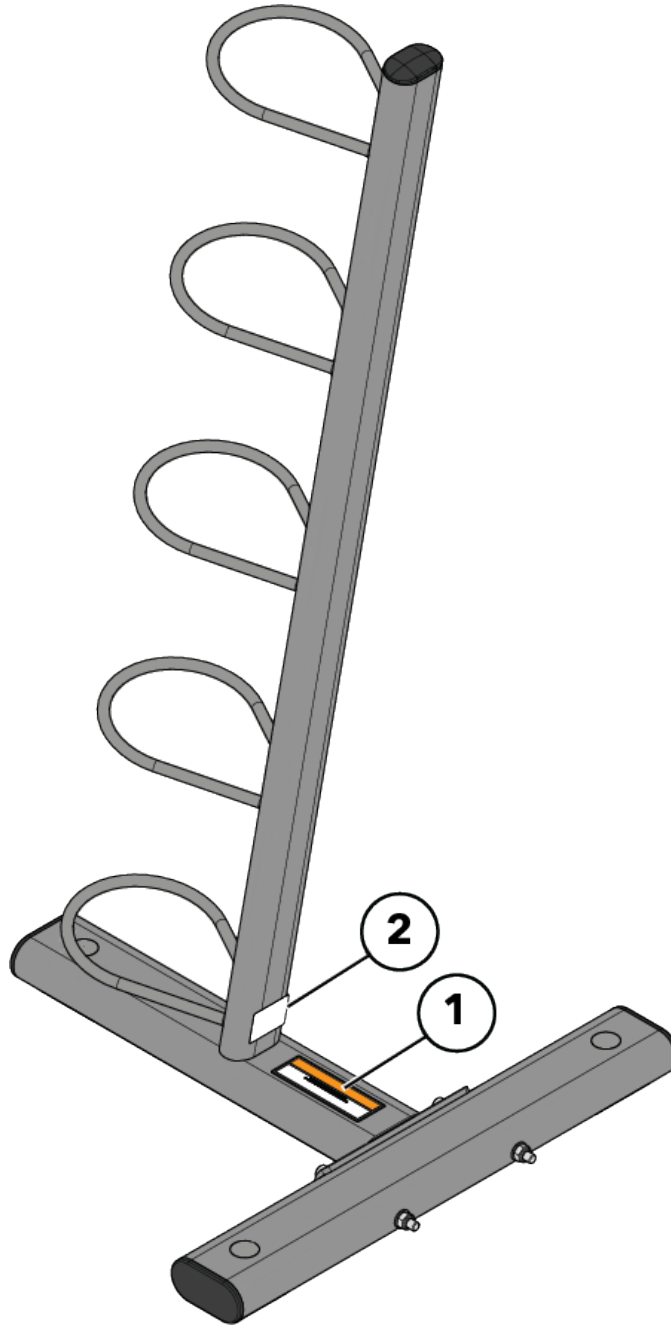

Item	Description	Qty.
1	General Warning	1
2	Serial Number	1

Olympic Squat Rack (LBR-OS)

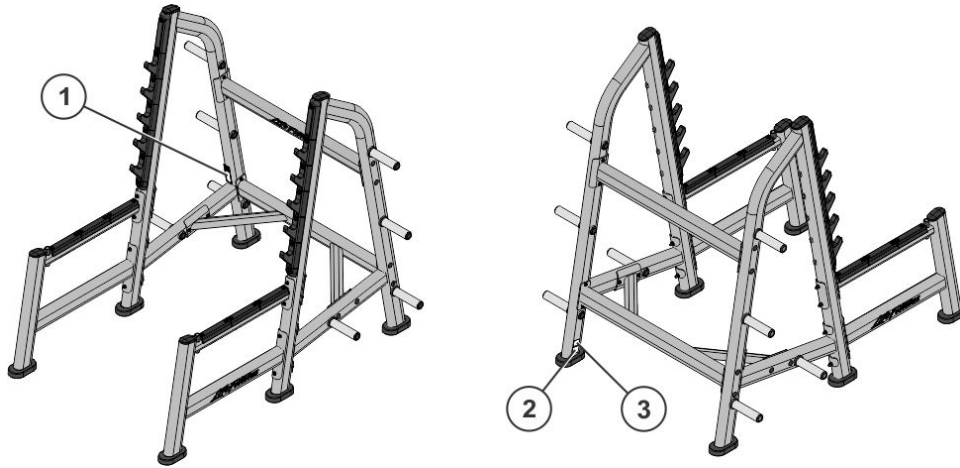

Item	Description	Qty.
1	General Warning	1
2	Serial Number	1
3	FCC Compliant	1

Olympic Weight Tree (LBR-OT)

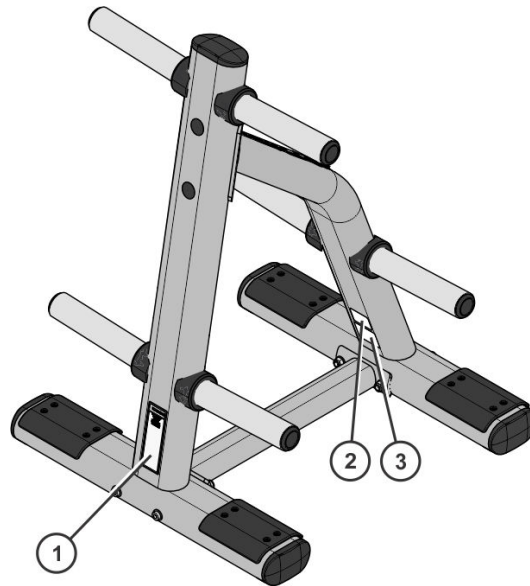

Item	Description	Qty.
1	General Warning	1
2	FCC Compliant	1
3	Serial Number	1

Two Tier Dumbbell Rack (LBR-D2)

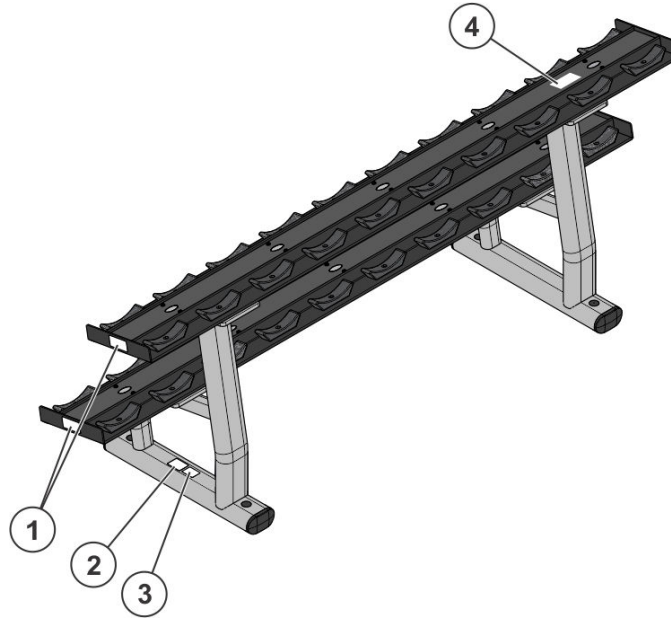

Item	Description	Qty.
1	150 lb Max. Dumbbell Weight	4
2	FCC Compliant	1
3	Serial Number	1
4	General Warning	1

Vertical Dumbbell Rack (LBR-DV)

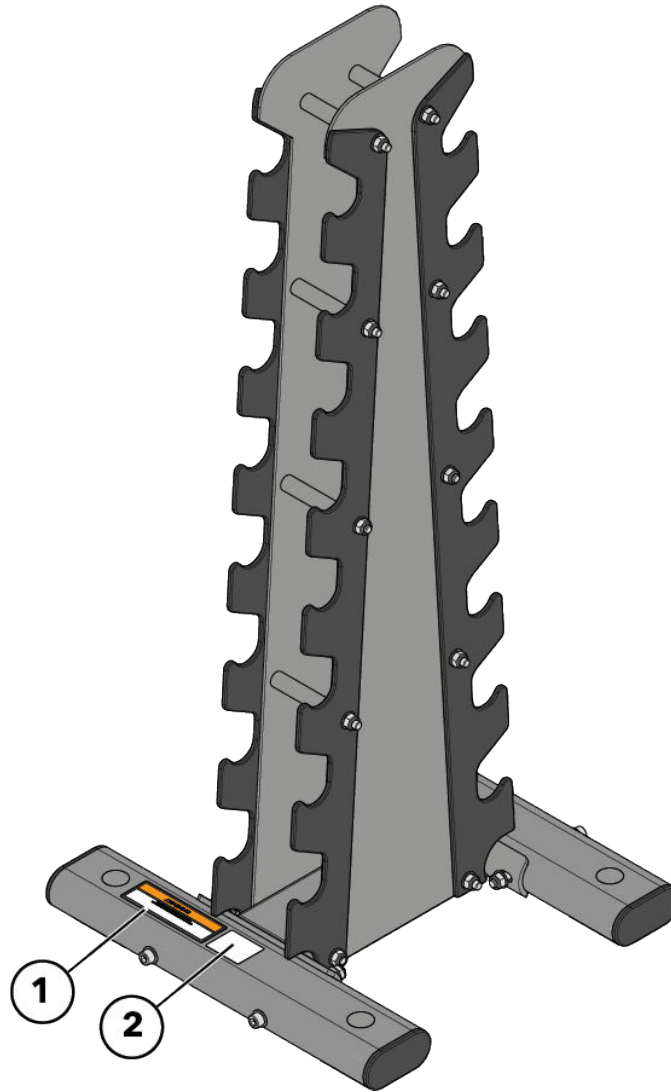

Item	Description	Qty.
1	General Warning	1
2	Serial Number	1

Vertical Dumbbell Rack 10 (LBR-DX)

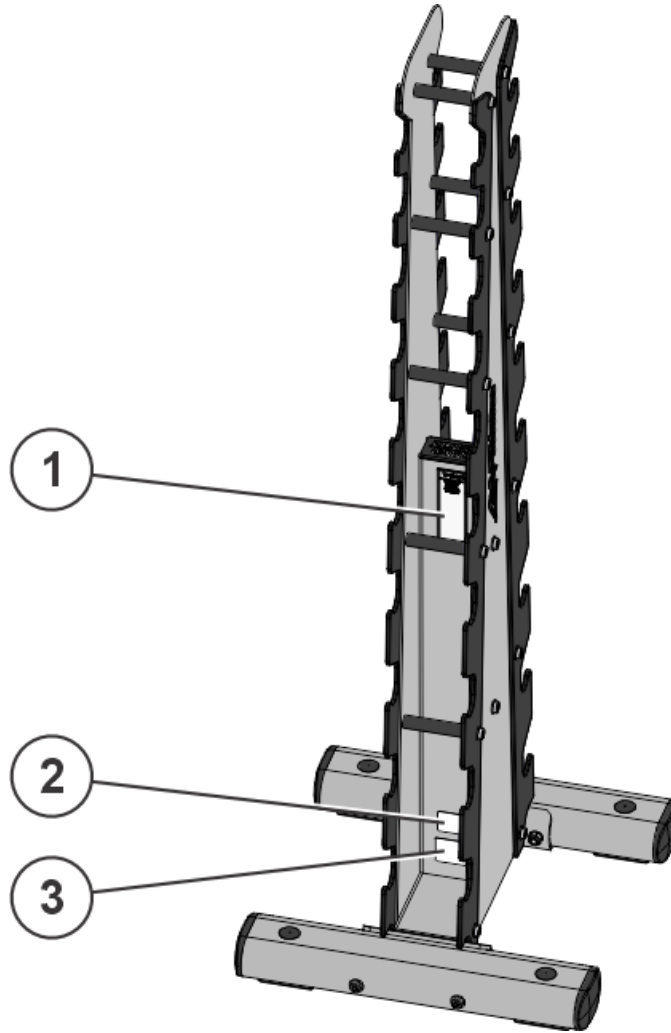

Item	Description	Qty.
1	General Warning	1
2	FCC Compliant	1
3	Serial Number	1

2. Product Information

Benches

Ab Bench (LBR-AB)

Machine Weight:	40 lbs.	18 kg.
Size (L x W x H):	in. = 50 x 25 x 21	cm = 127 x 64 x 53
Live Area (L x W):	in. = 75 x 43	cm = 191 x 109
Max User Weight:	300 lbs.	136 kg.

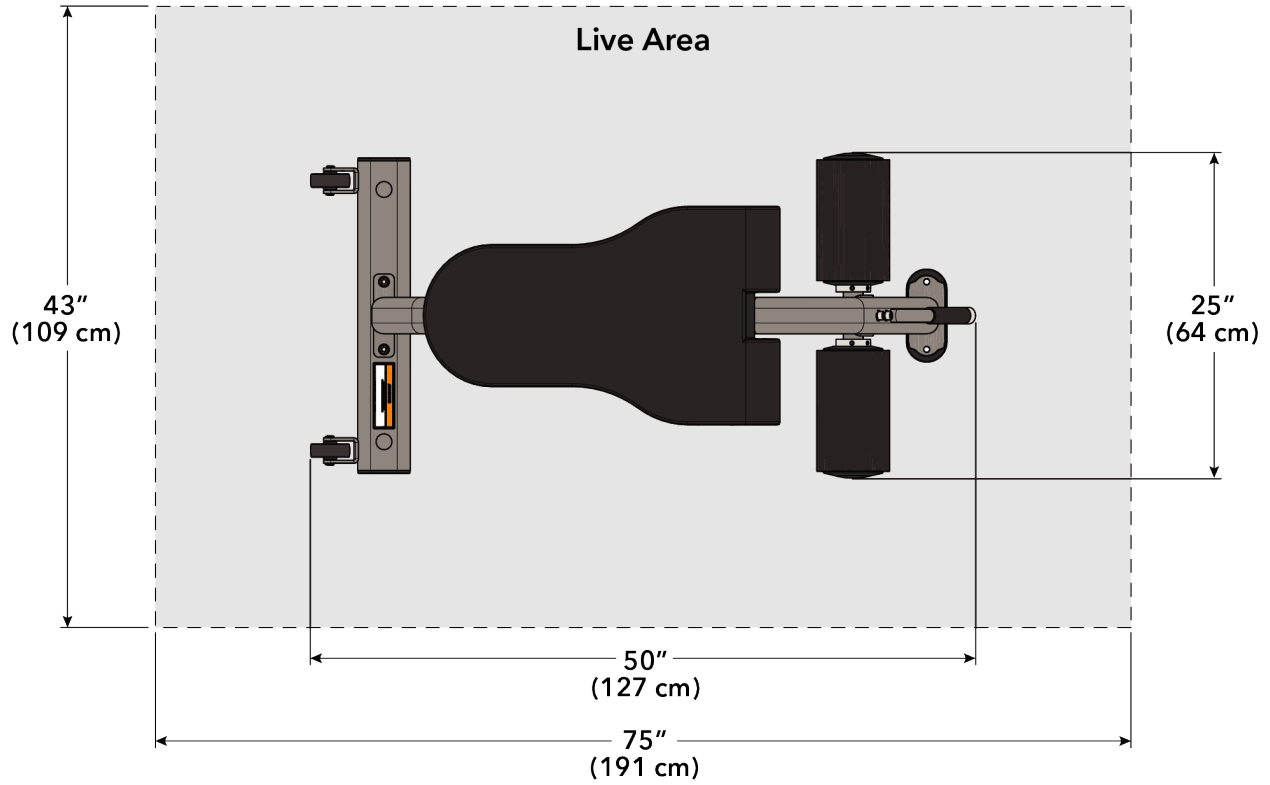

Abdominal Crunch Bench (LBR-AC)

Machine Weight:	168 lbs.	76 kg.
Size (L x W x H):	in. = 64 x 36 x 40	cm = 163 x 92 x 101
Live Area (L x W):	in. = 112 x 72	cm = 285 x 183
Max User Weight:	300 lbs.	136 kg.

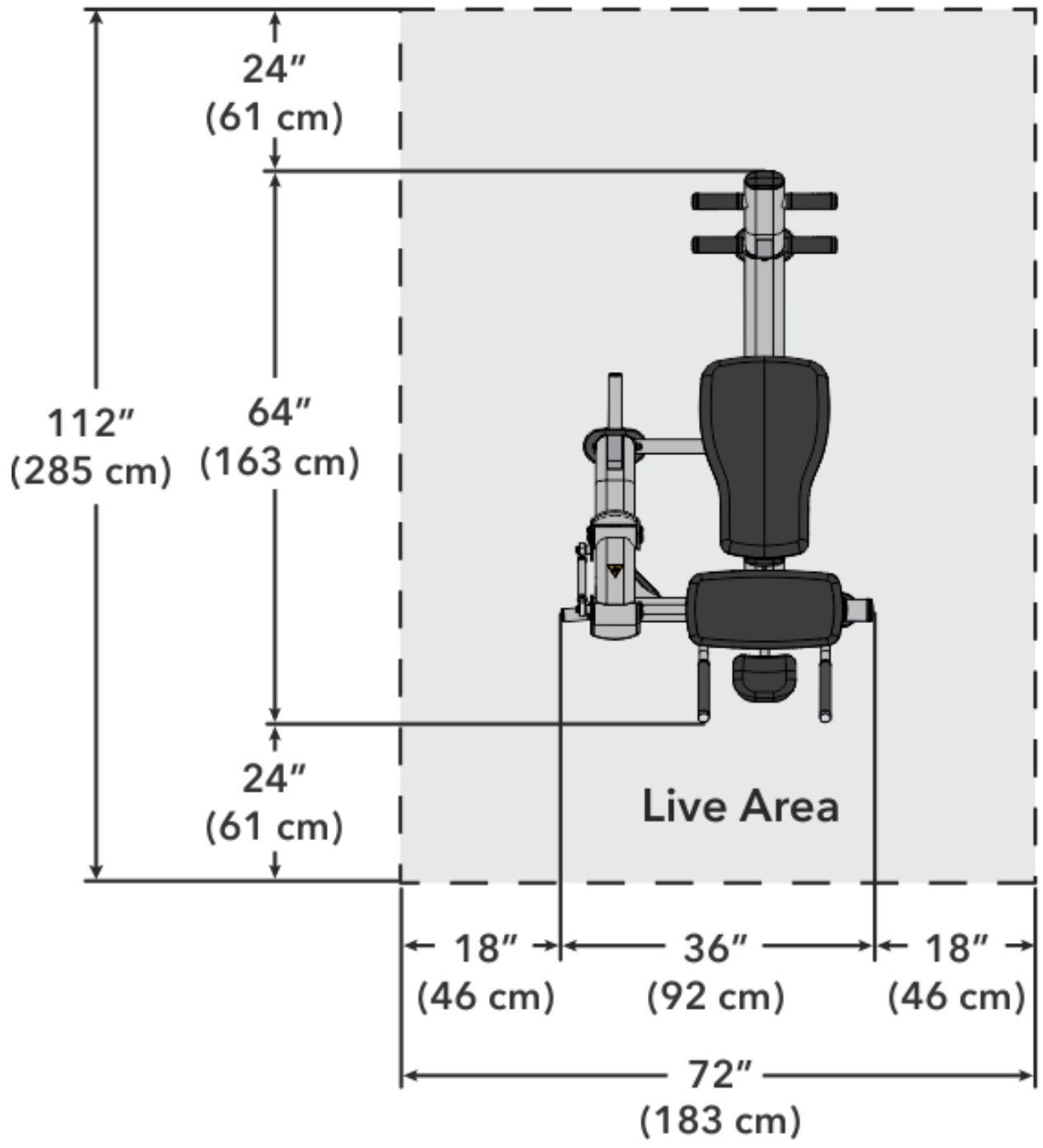

Adjustable Bench (LBR-AD)

Machine Weight:	72 lbs.	33 kg.
Size (L x W x H):	in. = 55 x 25 x 45	cm = 140 x 64 x 114
Live Area (L x W):	in. = 97 x 73	cm = 246 x 185
Max User Weight:	300 lbs.	136 kg.
Max Training Weight:	500 lbs.	225 kg.

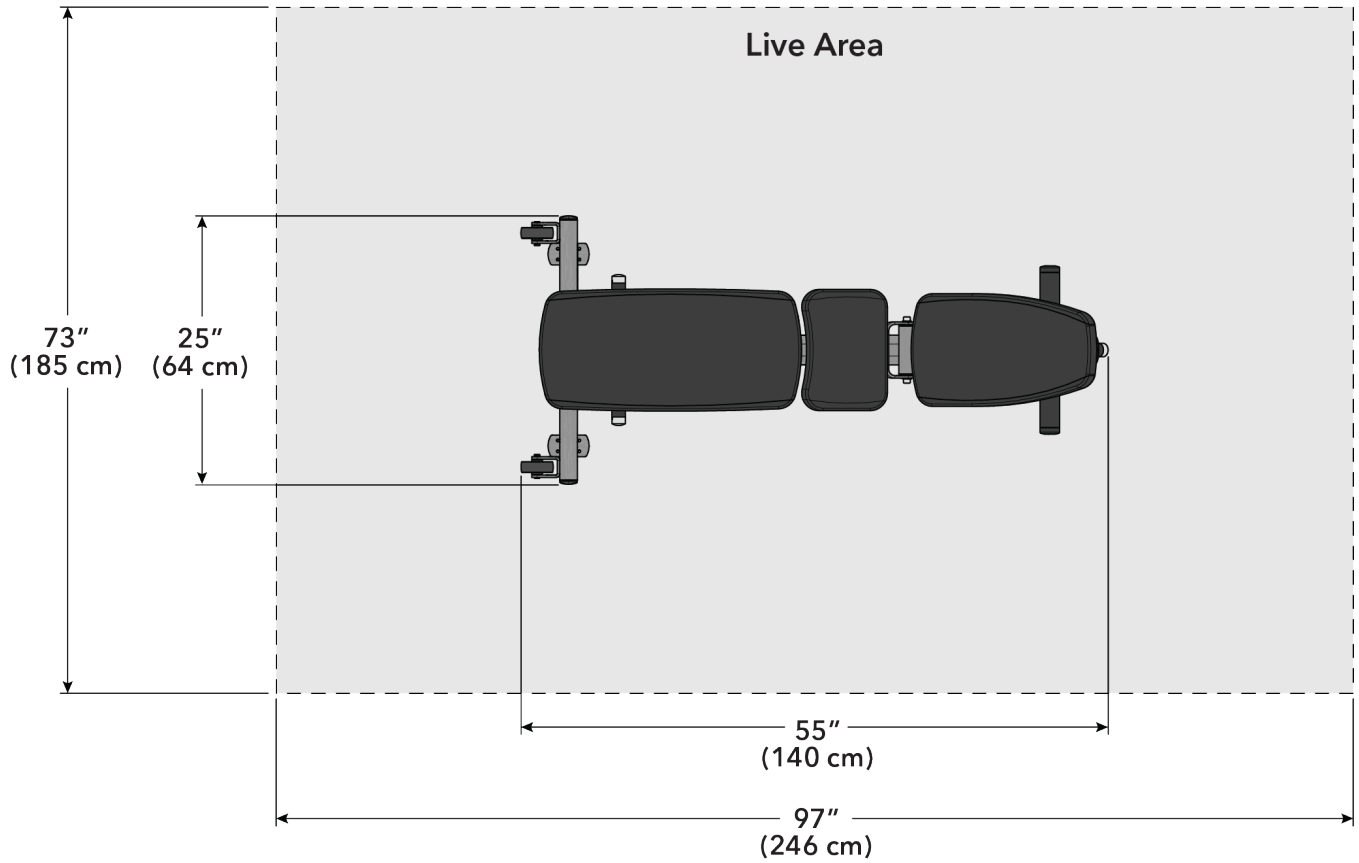

Biceps Curl Bench (LBR-BC)

Machine Weight:	193 lbs.	87.5 kg.
Size (L x W x H):	in. = 47 x 33 x 45	cm = 120 x 84 x 115
Live Area (L x W):	in. = 83 x 81	cm = 212 x 206
Max User Weight:	300 lbs.	136 kg.

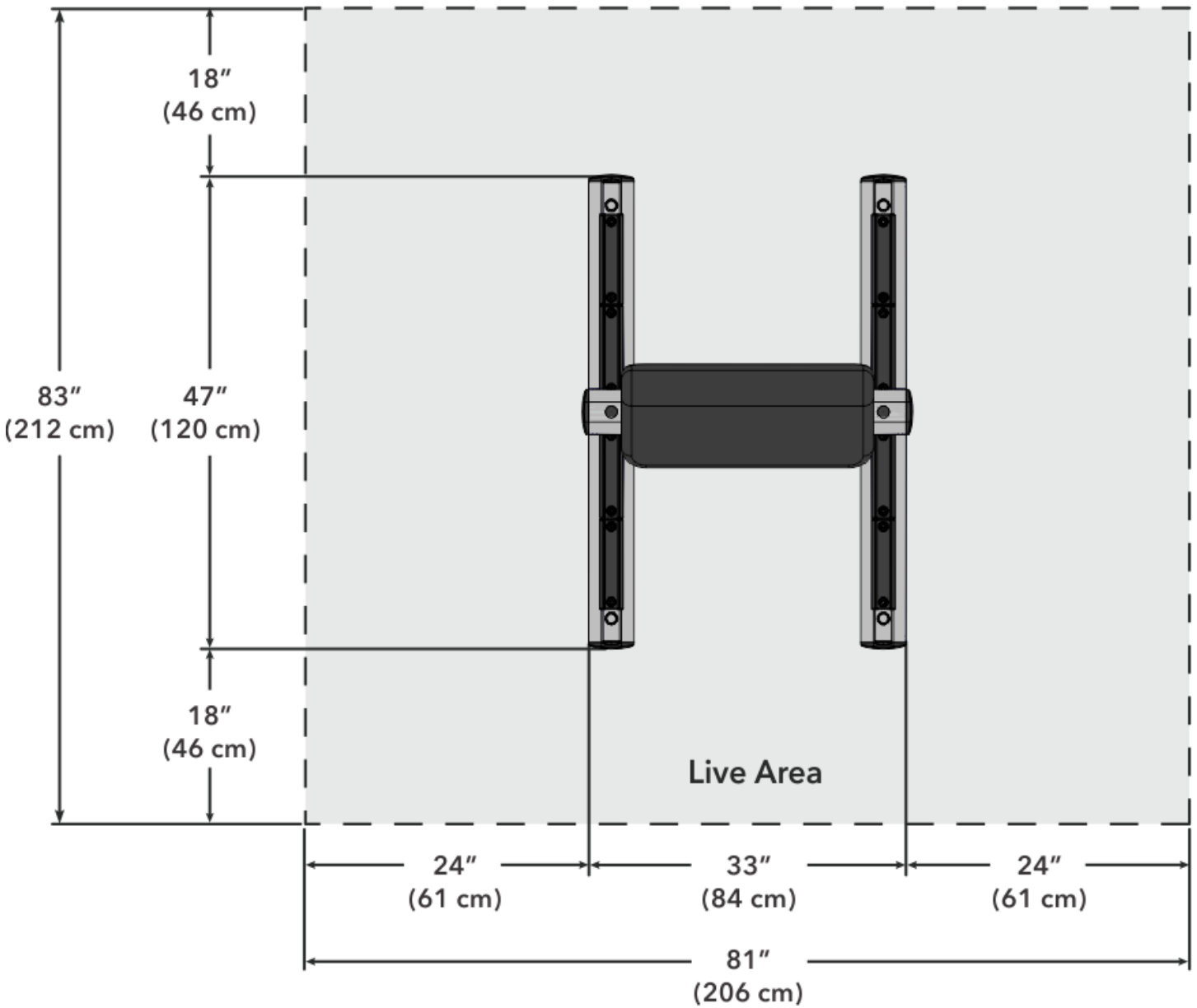

Back Extension (LBR-BE)

Machine Weight:	151 lbs.	69 kg.
Size (L x W x H):	in. = 50 x 74 x 38	cm = 128 x 94 x 97
Live Area (L x W):	in. = 74 x 73	cm = 189 x 186
Max User Weight:	300 lbs.	136 kg.

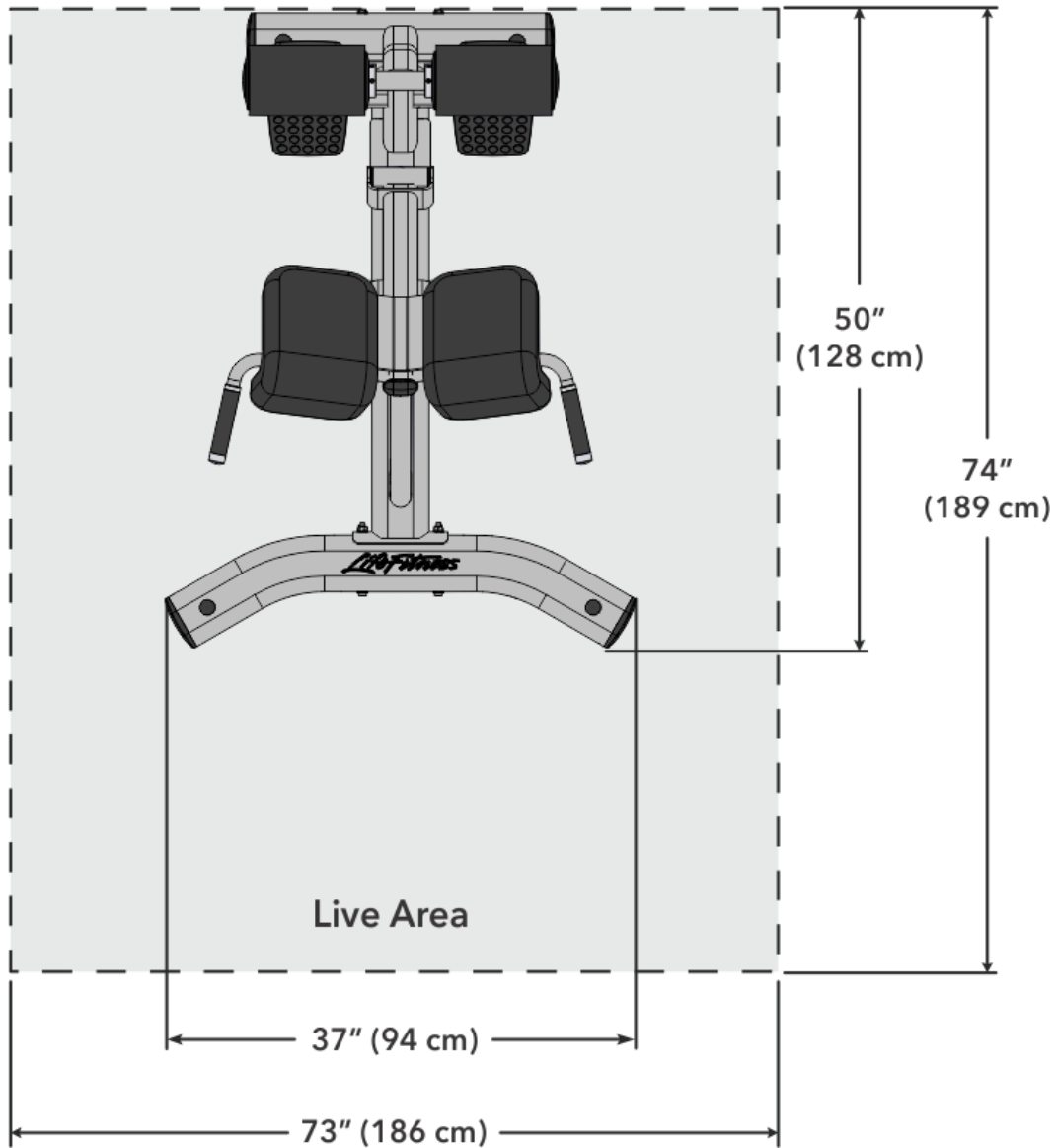

Decline Bench (LBR-DB)

Machine Weight:	117 lbs.	53 kg.
Size (L x W x H):	in. = 70 x 29 x 37	cm = 178 x 74 x 94
Live Area (L x W):	in. = 94 x 77	cm = 239 x 196
Max User Weight:	300 lbs.	136 kg.
Max Capacity:	800 lbs.	363 kg.

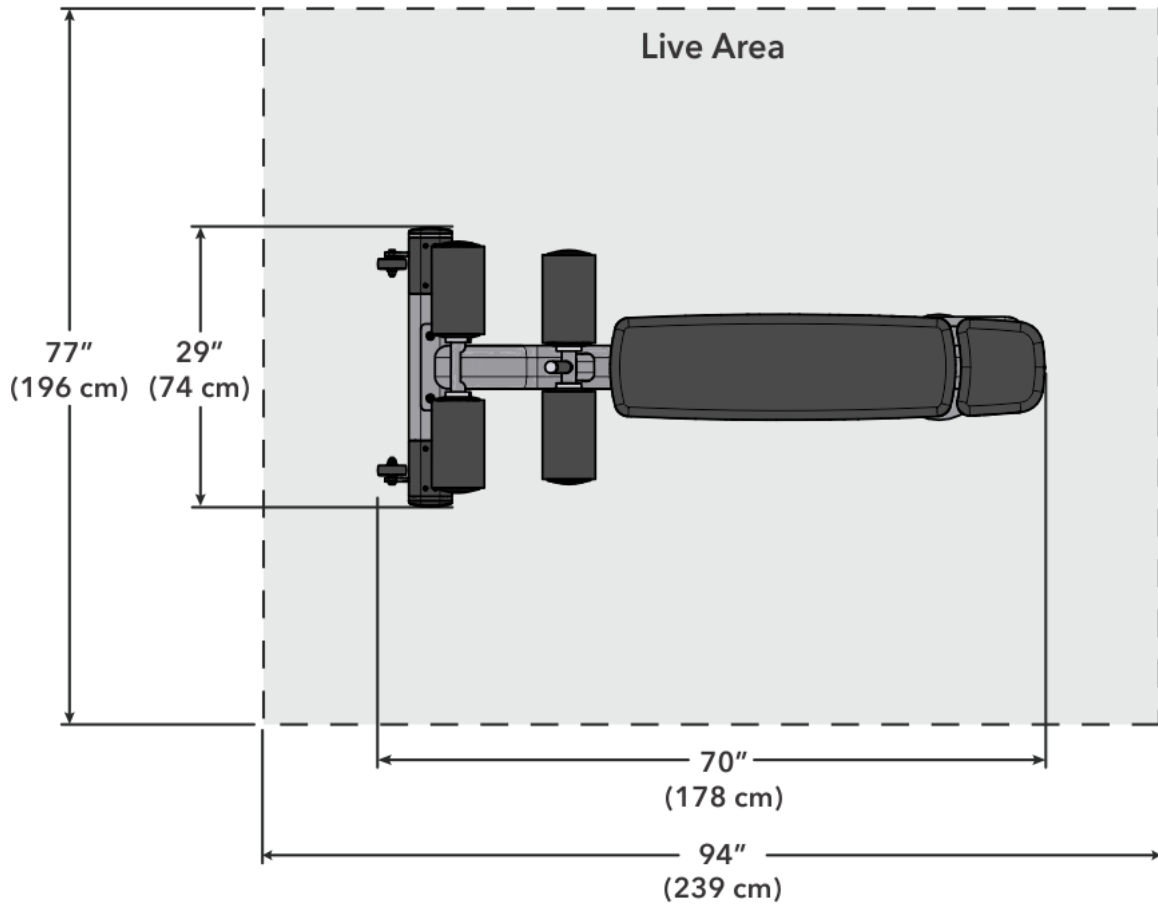

Dip Leg Raise (LBR-LD)

Machine Weight:	137 lbs.	62 kg.
Size (L x W x H):	in. = 41.5 x 29 x 61	cm = 105.4 x 73.6 x 155
Live Area (L x W):	in. = 77.5 x 47	cm = 197 x 119
Max User Weight:	300 lbs.	136 kg.

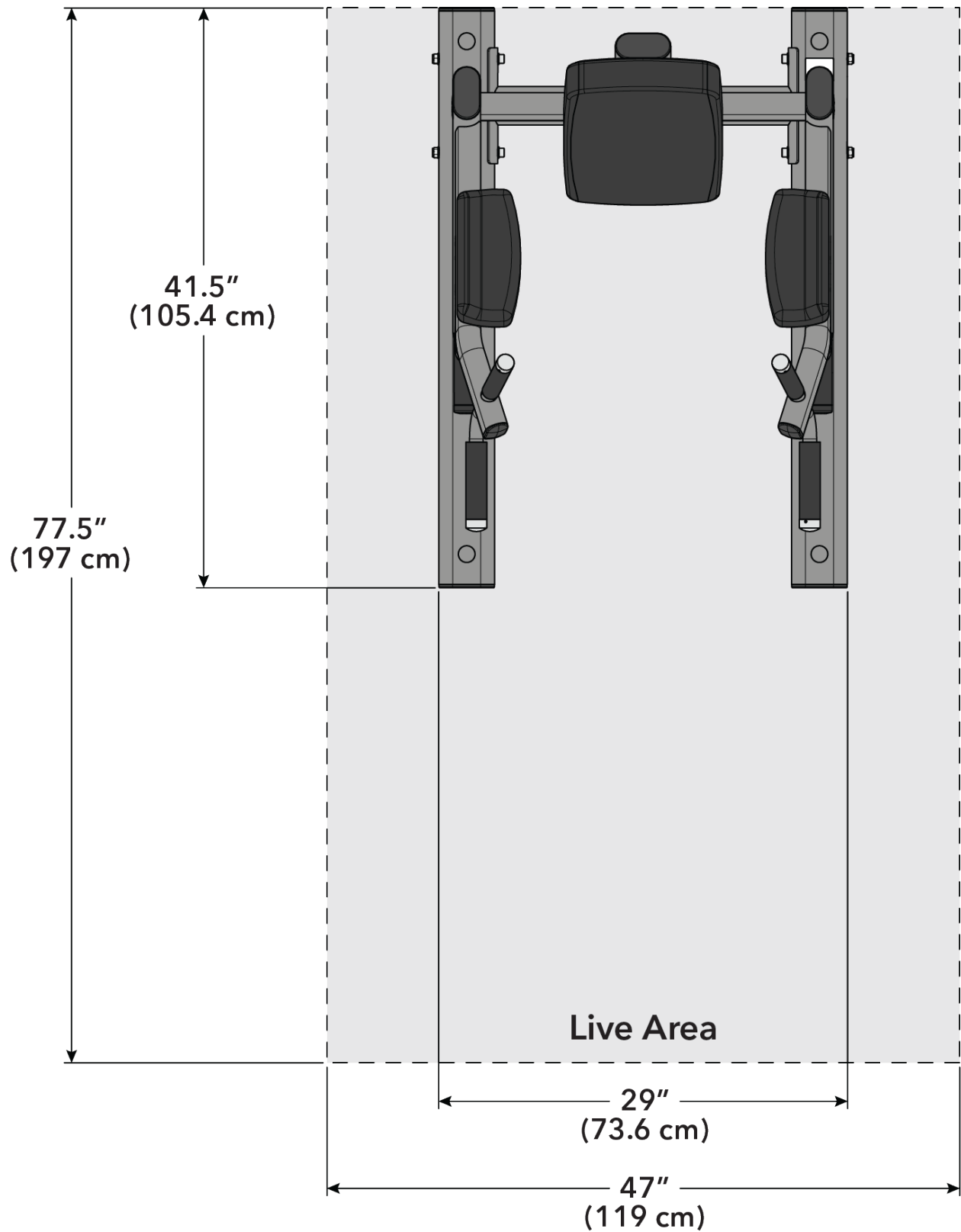

Flat Bench (LBR-FB)

Machine Weight:	85 lbs.	39 kg.
Size (L x W x H):	in. = 46 x 29 x 17	cm = 117 x 74 x 43
Live Area (L x W):	in. = 94 x 77	cm = 239 x 196
Max User Weight:	300 lbs.	136 kg.

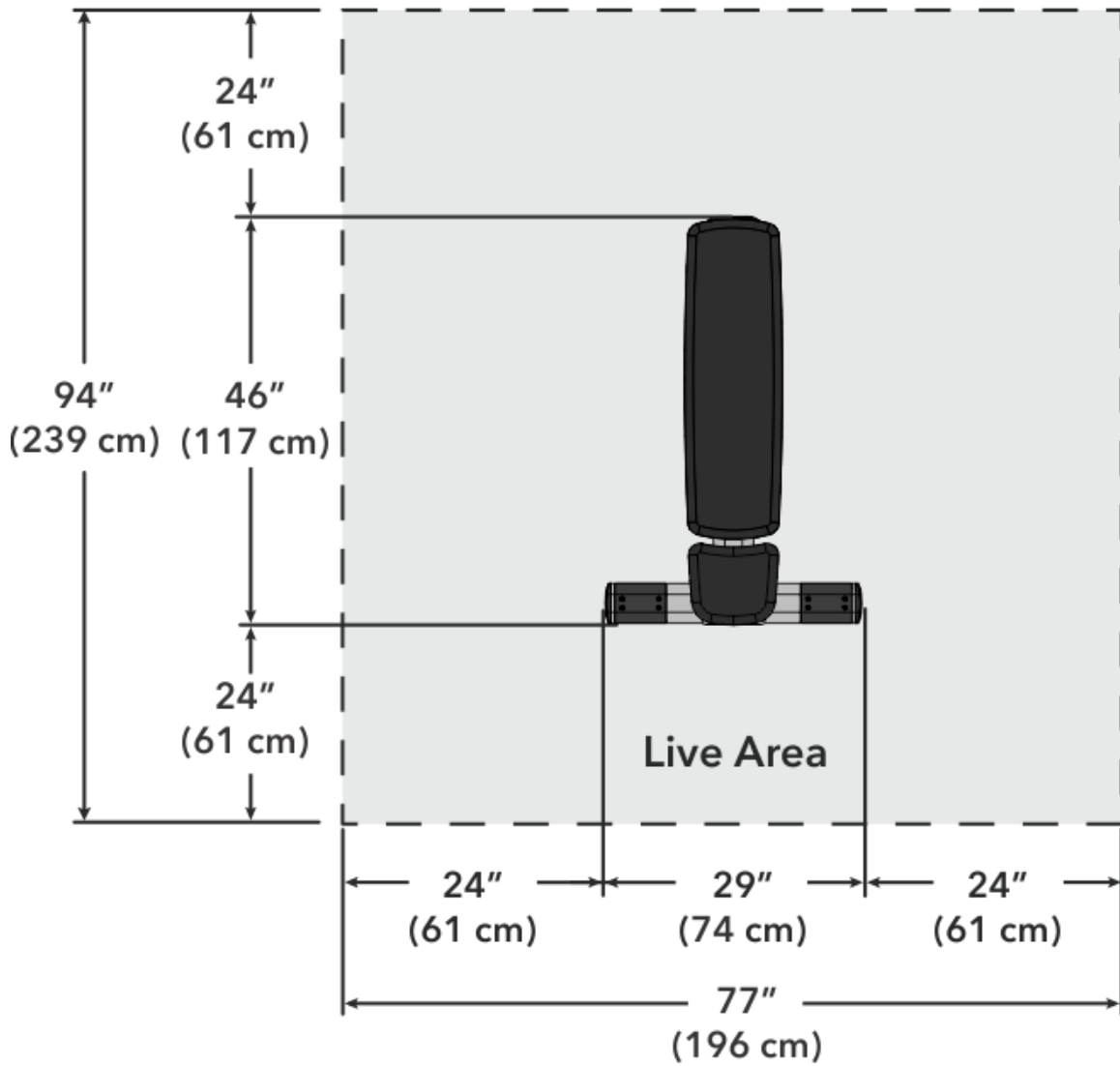

Flexibility Stretch (LBR-FS)

Machine Weight:	78 lbs.	35 kg.
Size (L x W x H):	in. = 54 x 23 x 43	cm = 137 x 58 x 109
Live Area (L x W):	in. = 78 x 59	cm = 198 x 150
Max User Weight:	300 lbs.	136 kg.

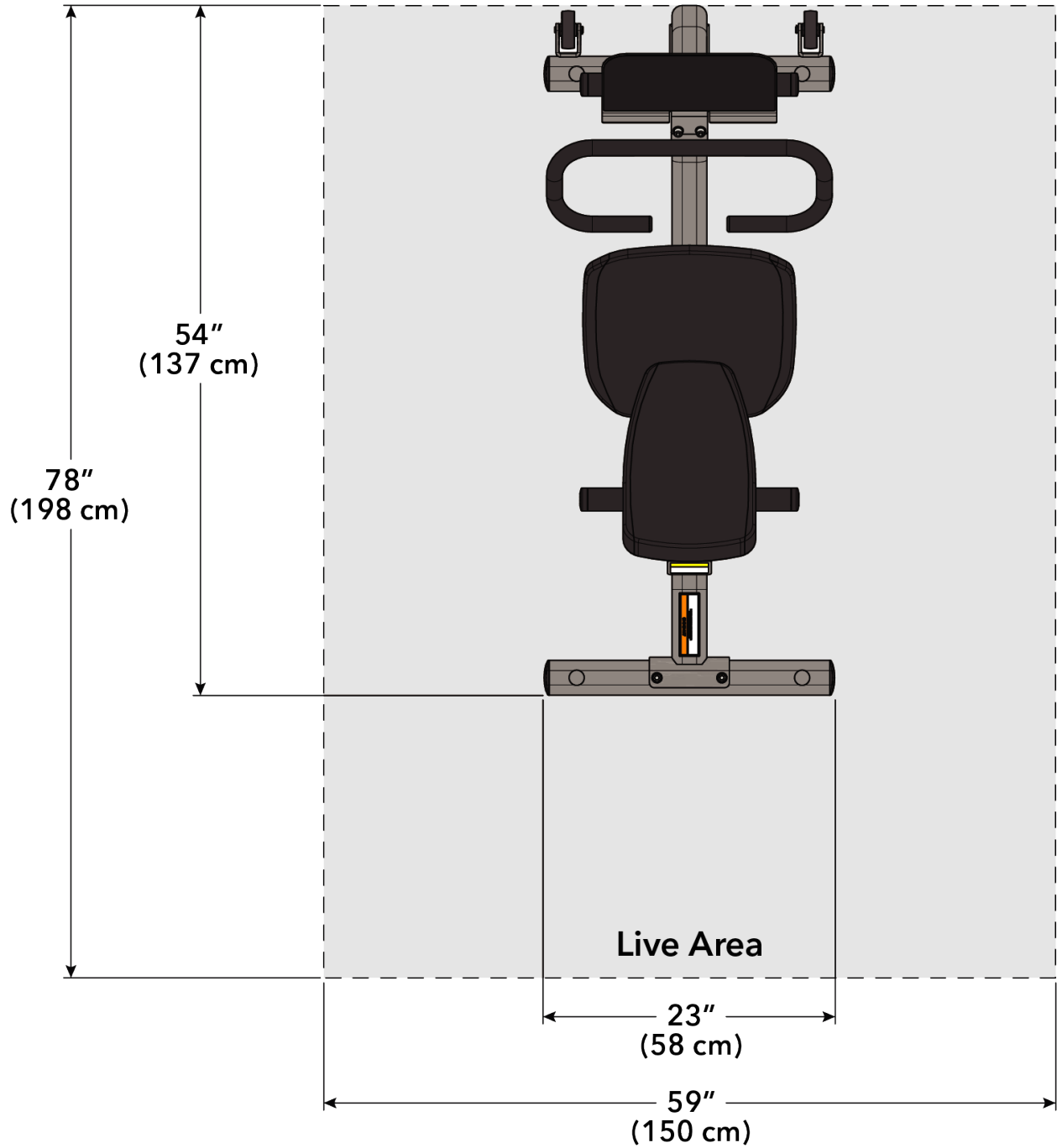

Leg Raise/Dip/Chin (LBR-LC)

Machine Weight:	256 lbs.	117 kg.
Size (L x W x H):	in. = 50 x 43 x 92	cm = 127 x 109 x 234
Live Area (L x W x H):	in. = 67 x 68 x 110	cm = 170 x 173 x 280
Max User Weight:	300 lbs.	136 kg.

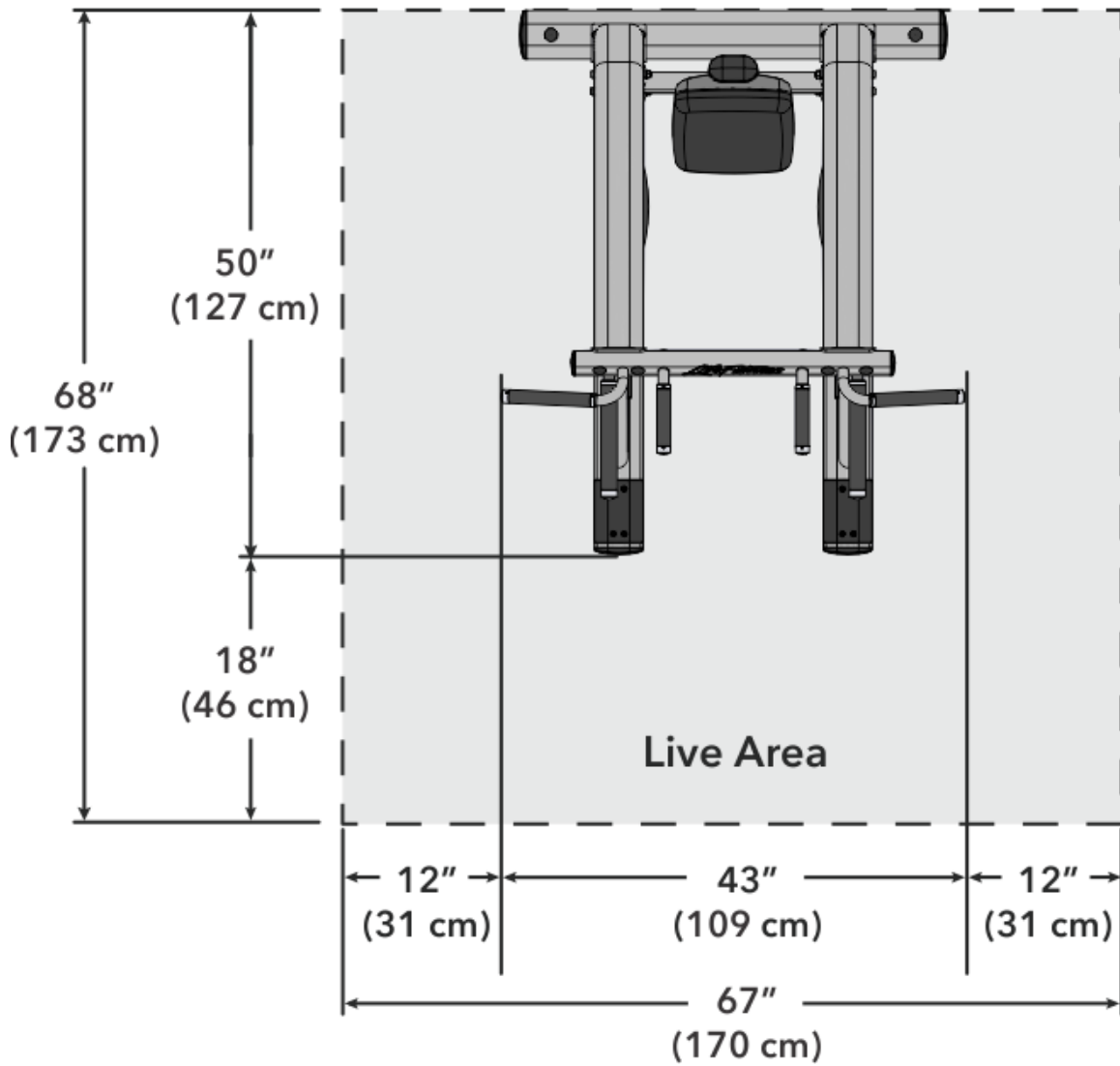

Leg Raise (LBR-LR)

Machine Weight:	160 lbs.	72.6 kg.
Size (L x W x H):	in. = 46 x 33 x 62	cm = 116.8 x 83.8 x 157.5
Live Area (L x W):	in. = 64 x 57	cm = 162.5 x 144.8
Max User Weight:	300 lbs.	136 kg.

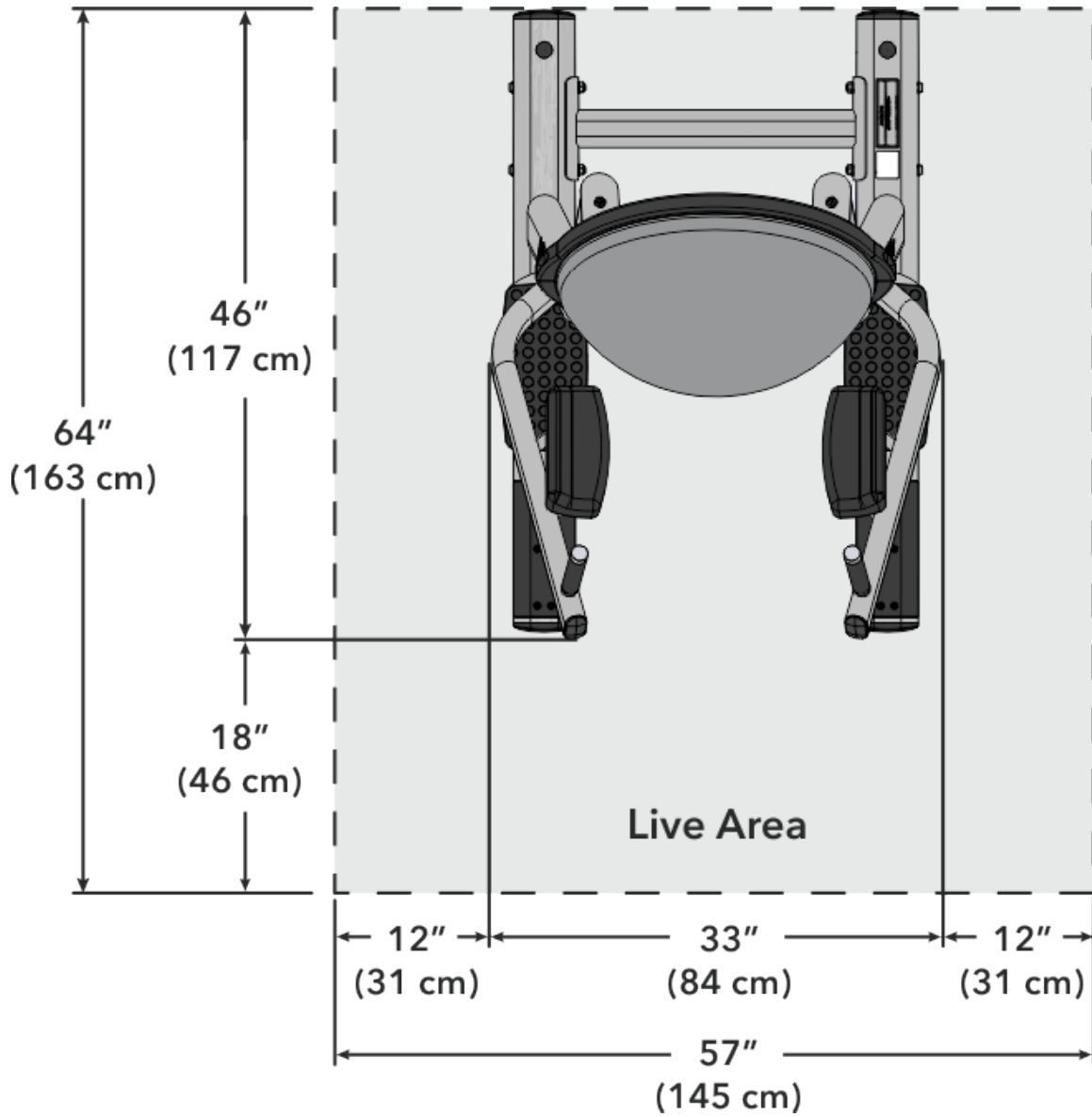

Multi-Adjustable Bench (LBR-MA)

Machine Weight:	100 lbs.	45 kg.
Size (L x W x H):	in. = 57 x 29 x 48	cm = 145 x 73 x 122
Live Area (L x W):	in. = 81 x 77	cm = 206 x 196
Max User Weight:	300 lbs.	136 kg.
Max Capacity:	800 lbs.	363 kg.

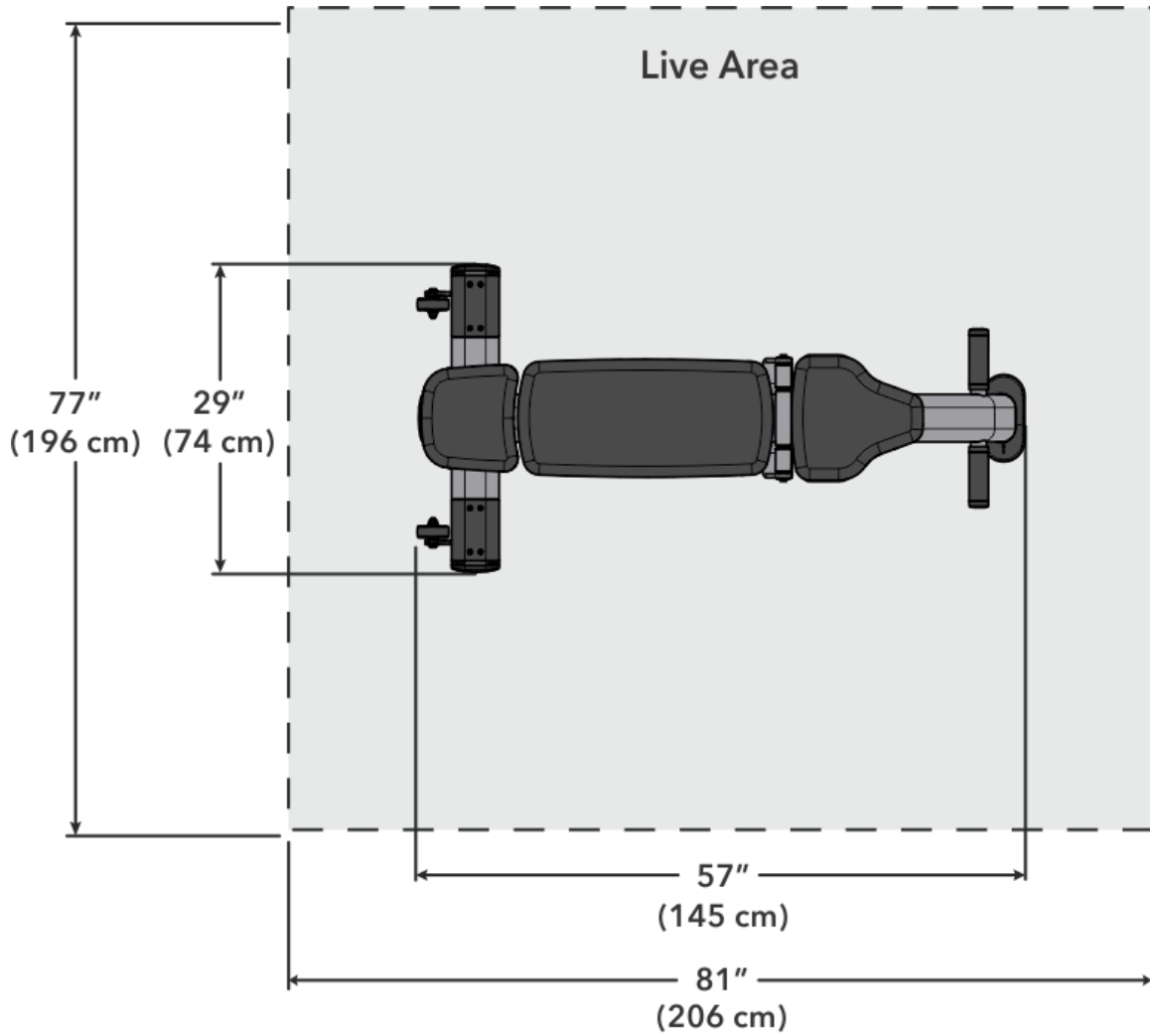

Olympic Decline Bench (LBR-OD)

Machine Weight:	393 lbs.	179 kg.
Size (L x W x H):	in. = 114 x 51 x 51	cm = 120 x 130 x 130
Live Area (L x W):	in. = 95 x 99	cm = 242 x 252
Max User Weight:	300 lbs.	136 kg.

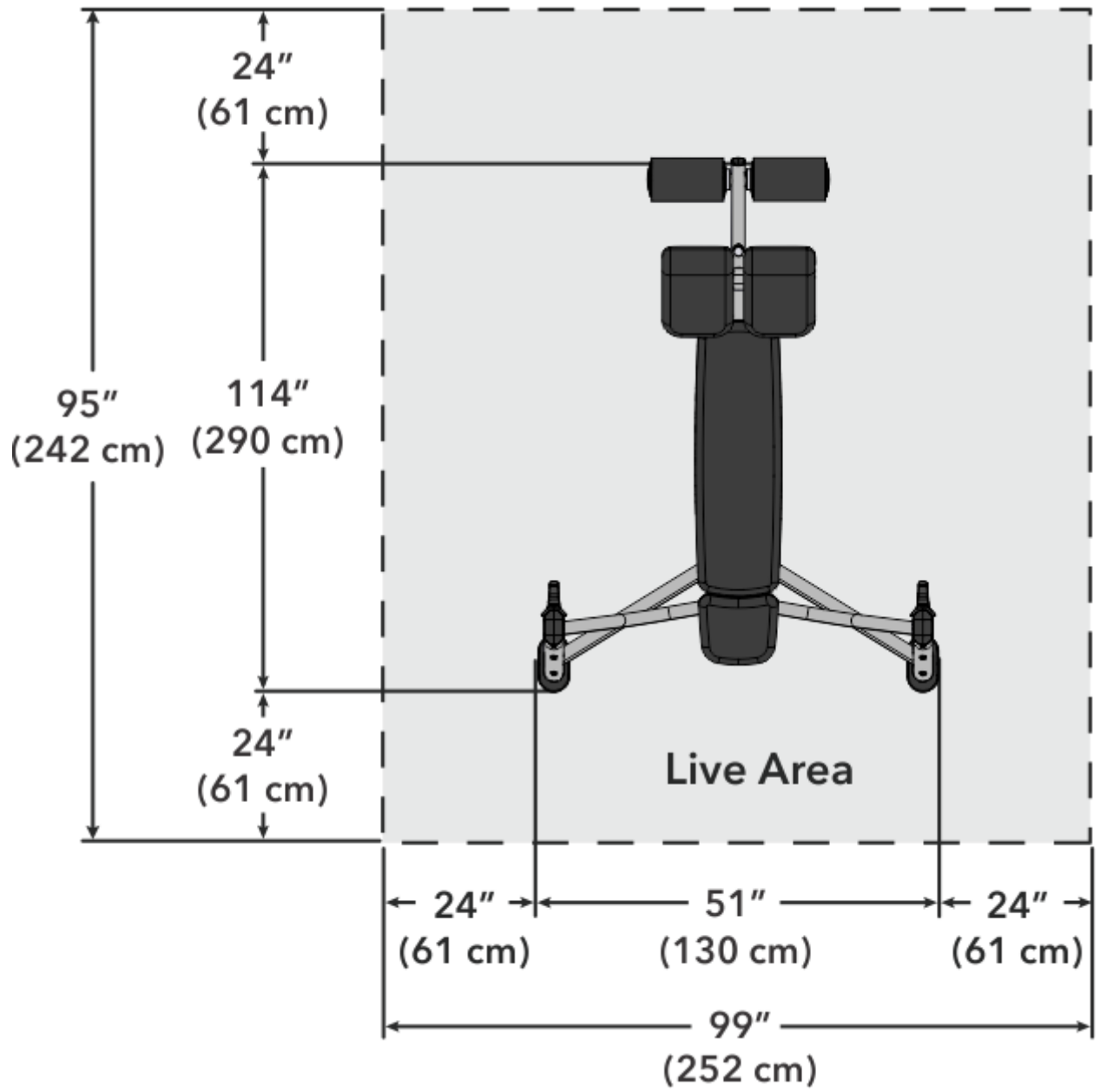

Olympic Flat Bench (LBR-OF)

Machine Weight:	150 lbs.	68 kg.
Size (L x W x H):	in. = 47 x 51 x 52	cm = 120 x 130 x 132
Live Area (L x W):	in. = 95 x 99	cm = 242 x 252
Max User Weight:	300 lbs.	136 kg.

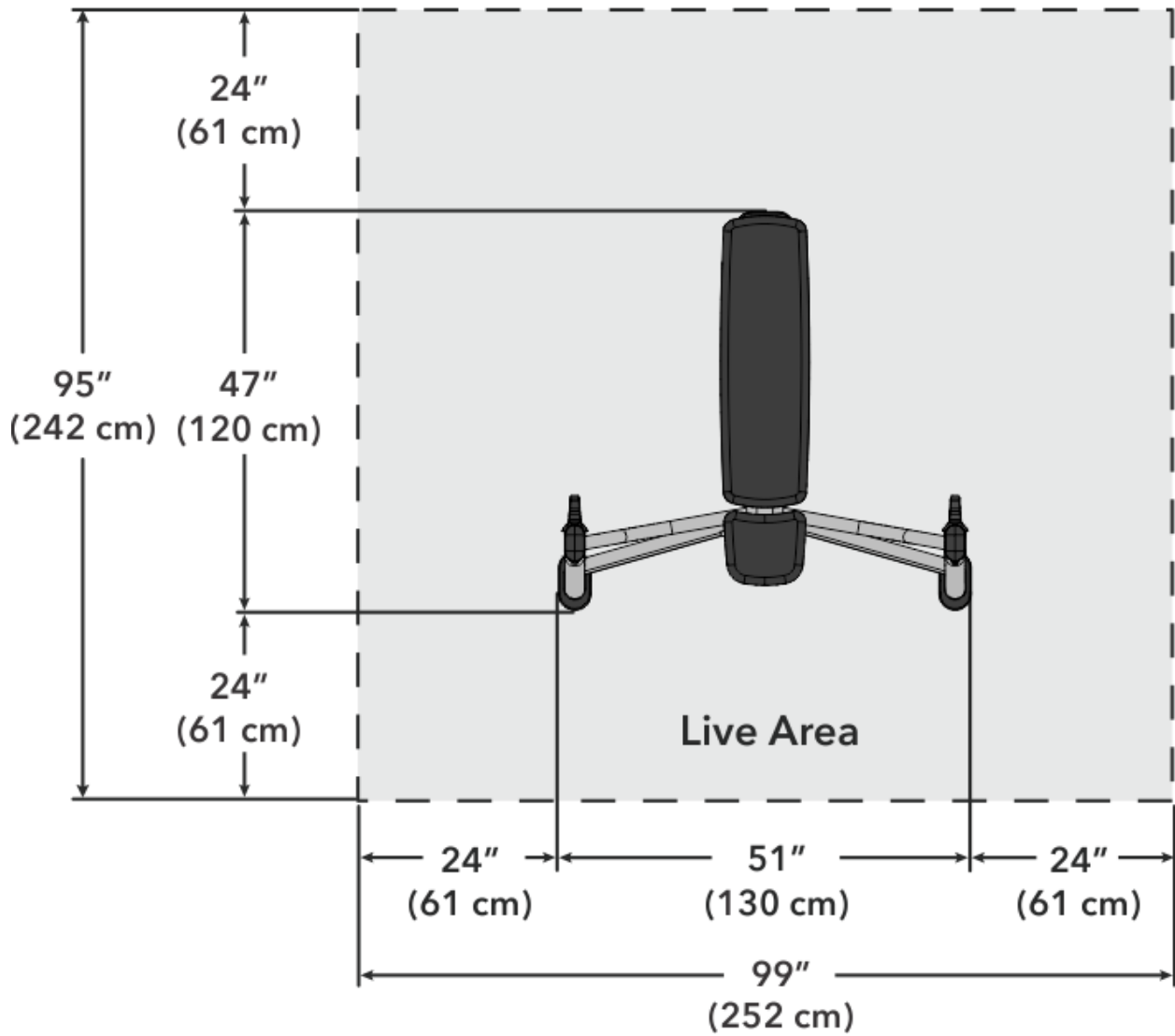

Olympic Incline Bench (LBR-OI)

Machine Weight:	178 lbs.	81 kg.
Size (L x W x H):	in. = 56 x 58 x 57	cm = 143 x 148 x 145
Live Area (L x W):	in. = 265 x 270	cm = 265 x 270
Max User Weight:	300 lbs.	136 kg.

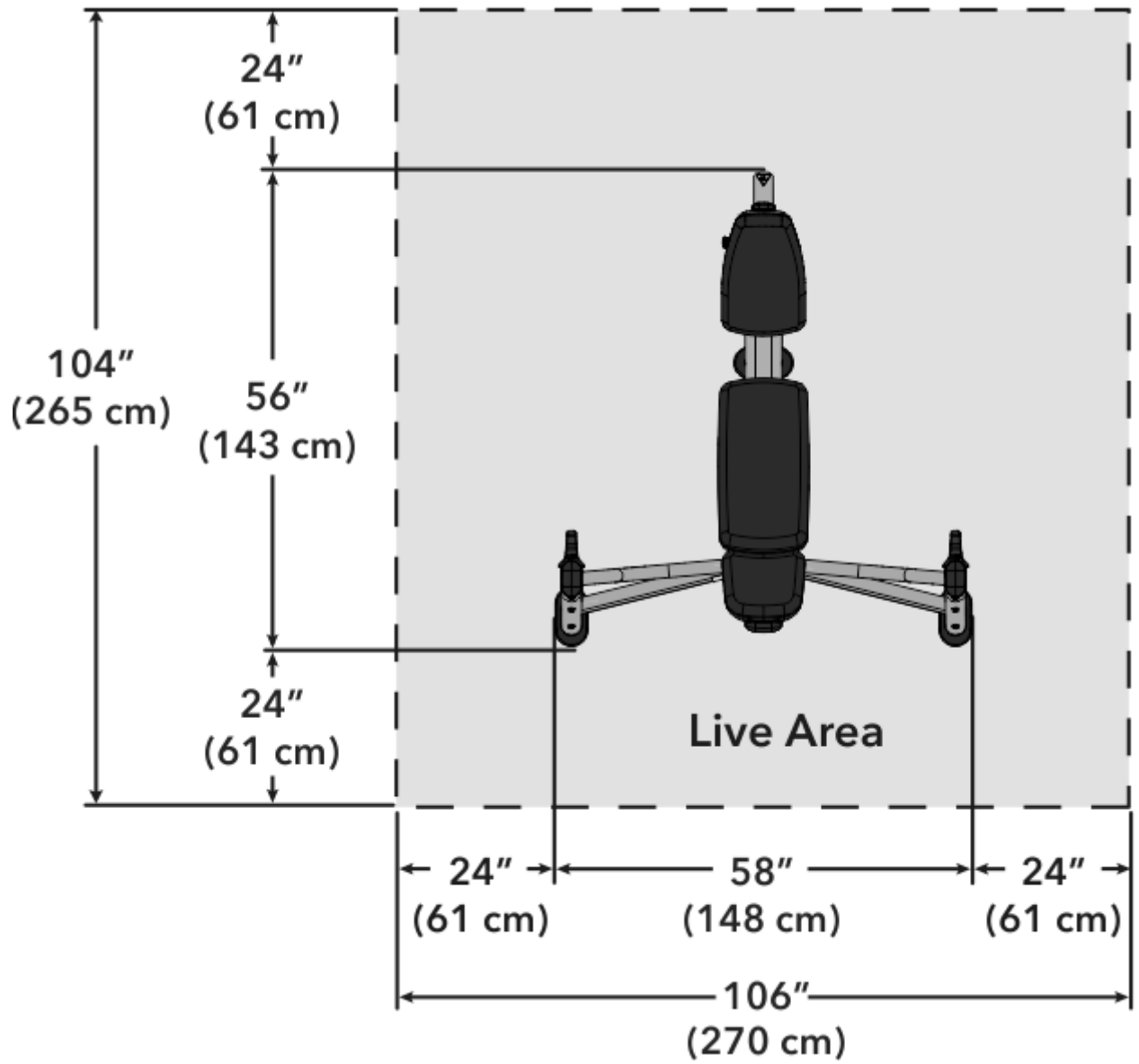

Olympic Military Bench (LBR-OM)

Machine Weight:	269 lbs.	122 kg.
Size (L x W x H):	in. = 51 x 51 x 70	cm = 130 x 130 x 178
Live Area (L x W):	in. = 99 x 99	cm = 252 x 252
Max User Weight:	300 lbs.	136 kg.

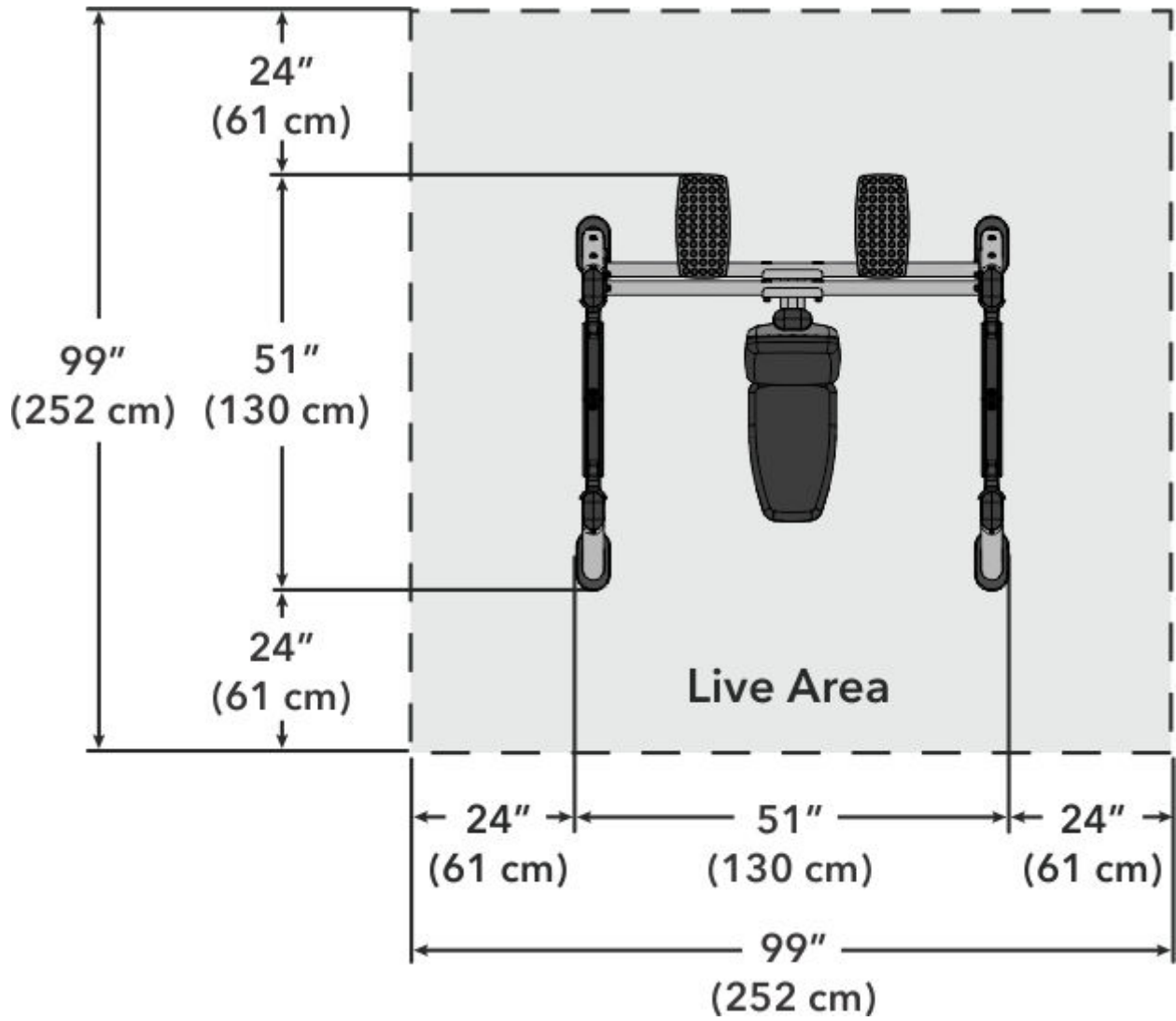

Olympic Bench Weight Storage (LBR-OW)

Machine Weight:	85 lbs.	38.3 kg.
Size (L x W x H):	in. = 28 x 18 x 49	cm = 72 x 46 x 125
Live Area (L x W):	in. = 52 x 42	cm = 132 x 107

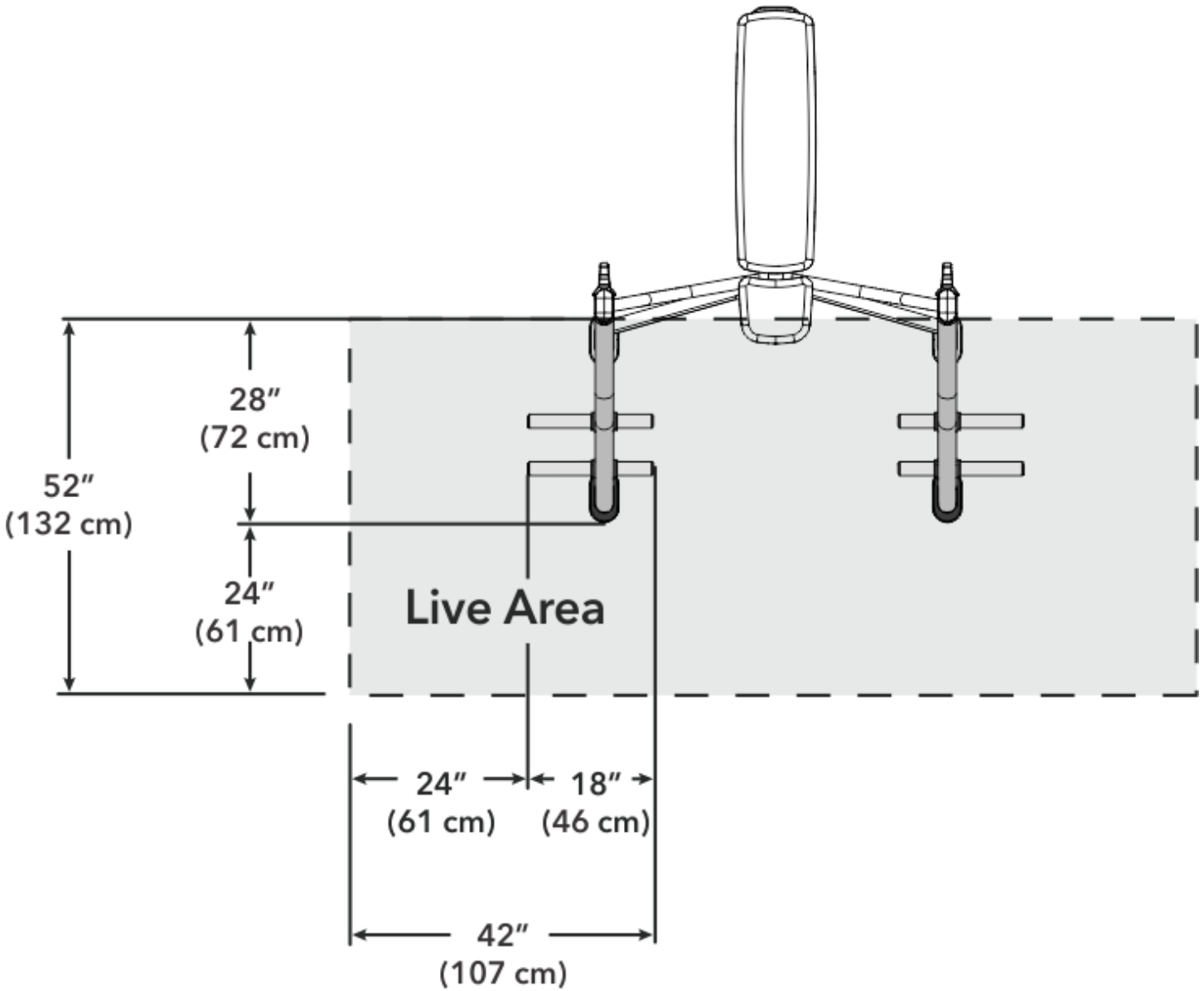

Utility Bench (LBR-UB)

Machine Weight:	65 lbs.	29.5 kg.
Size (L x W x H):	in. = 36 x 29 x 36	cm = 92 x 74 x 92
Live Area (L x W):	in. = 78 x 77	cm = 199 x 196
Max User Weight:	300 lbs.	136 kg.

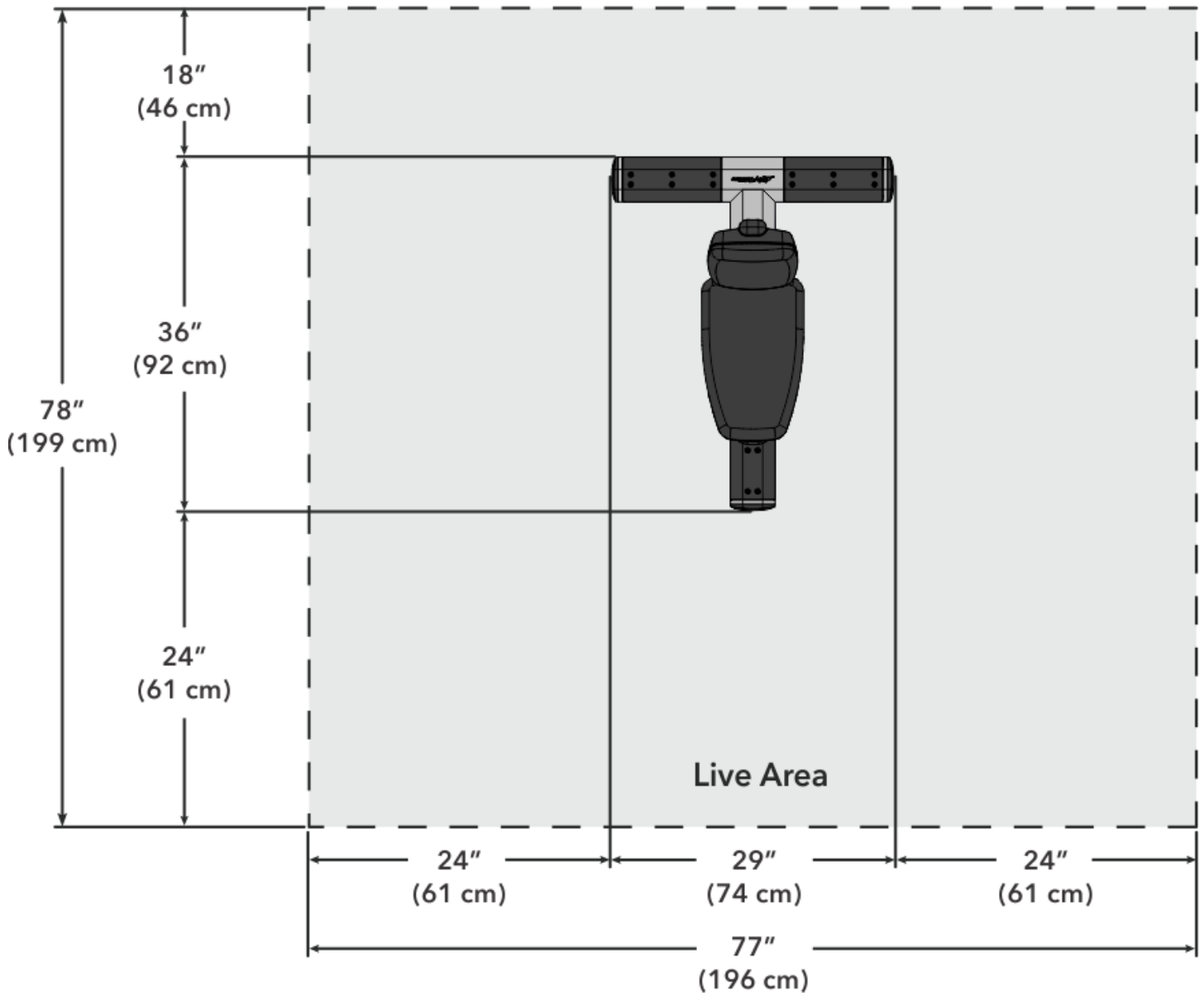

Racks

Accessory Rack (LBR-AR)

Machine Weight:	168 lbs.	76 kg.
Size (L x W x H):	in. = 54 x 29 x 38	cm = 137 x 73 x 96
Live Area (L x W):	in. = 54 x 53	cm = 137 x 135
Storage Capacity:	270 lbs./tier	120 kg./tier

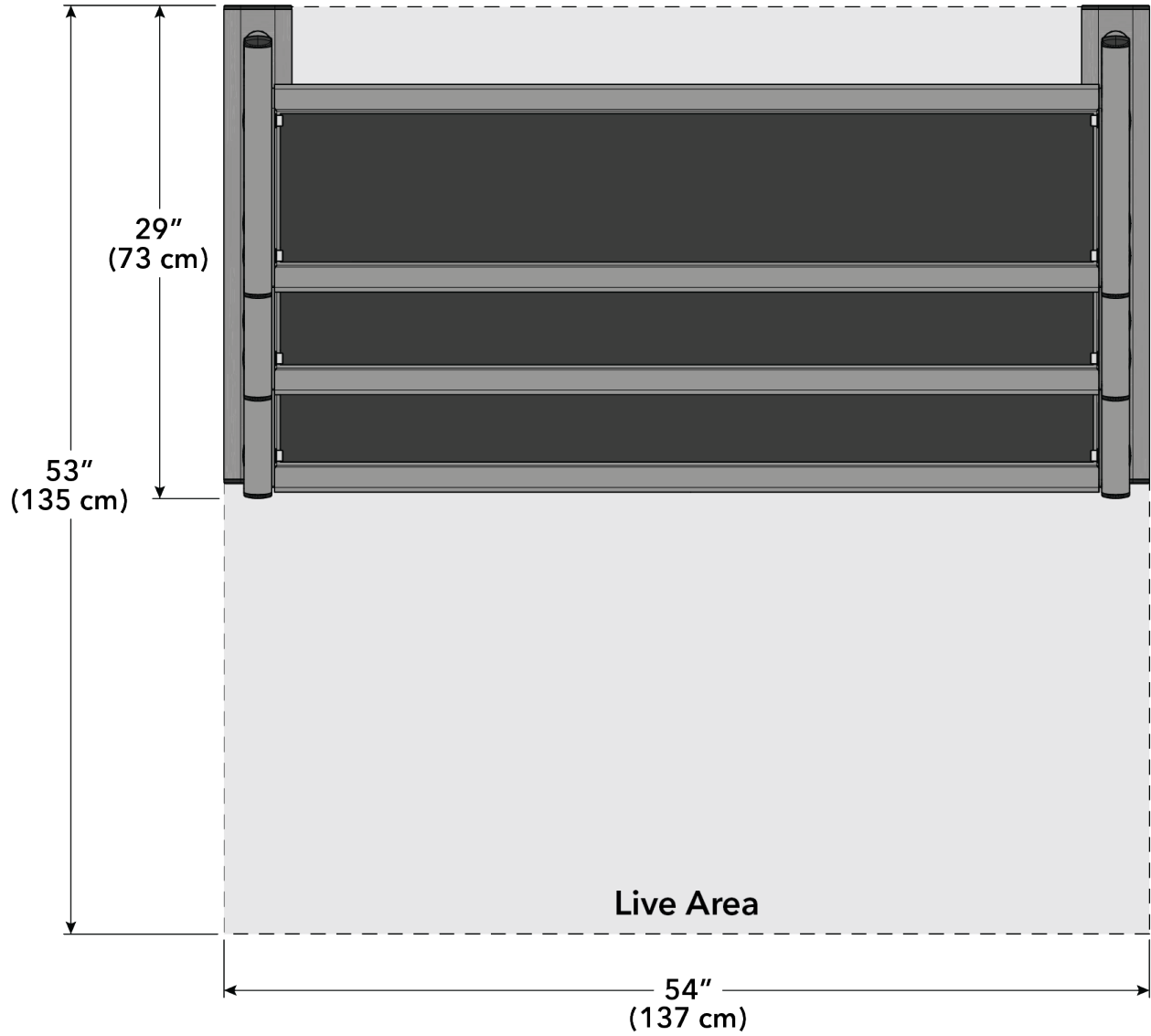

Barbell Rack (LBR-BB)

Machine Weight:	92 lbs.	42 kg.
Size (L x W x H):	in. = 36 x 23.5 x 56.5	cm = 91.5 x 60 x 143.5
Live Area (L x W):	in. = 60 x 47.5	cm = 152 x 121
Storage Weight:	450 lbs.	204 kg.

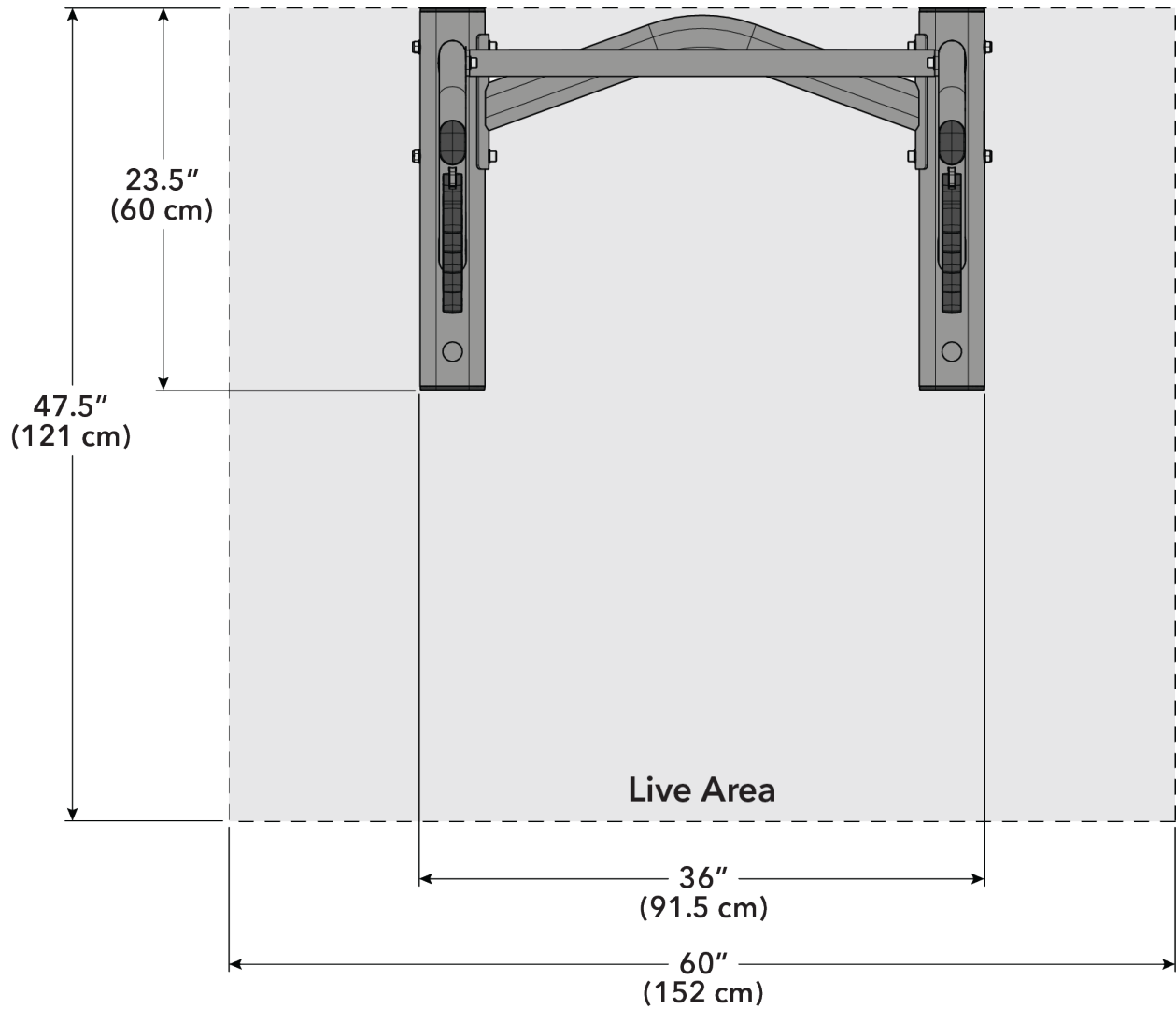

Barbell Rack (LBR-BR)

Machine Weight:	128.5 lbs.	58.2 kg.
Size (L x W x H):	in. = 36 x 33 x 57	cm = 91.5 x 83.8 x 144.9
Live Area (L x W):	in. = 60 x 81	cm = 152 x 205.7
Storage Weight:	900 lbs.	408 kg.

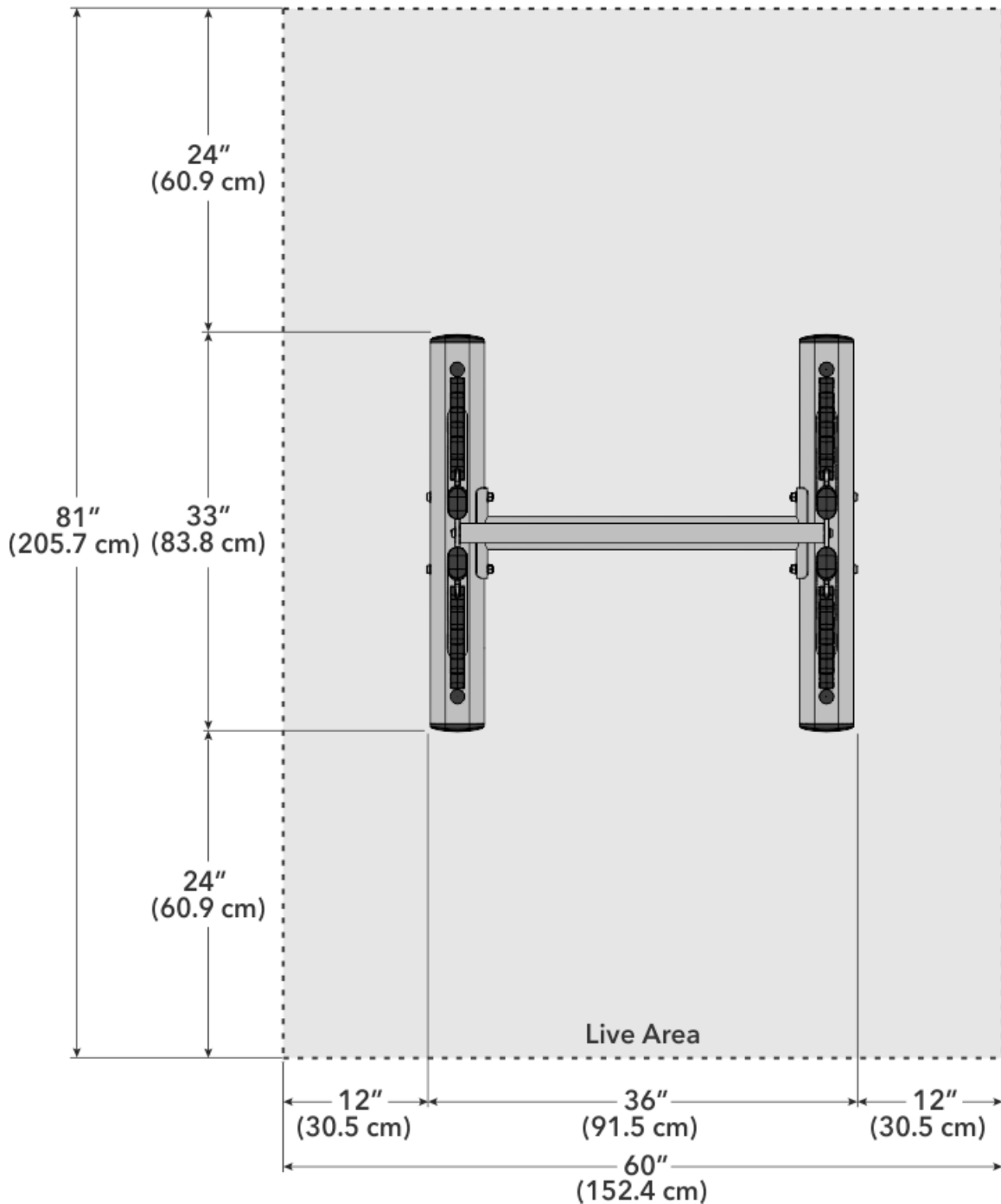

Hex Dumbbell Rack (LBR-DF)

Machine Weight:	167 lbs.	76 kg.
Size (L x W x H):	in. = 54 x 29 x 38	cm = 137 x 73 x 96
Live Area (L x W):	in. = 54 x 53	cm = 137 x 135
Storage Capacity:	270 lbs./tier	120 kg./tier
Max Load:	1 set of 5 lb.-50 lb. hex dumbbells (550 lbs)	

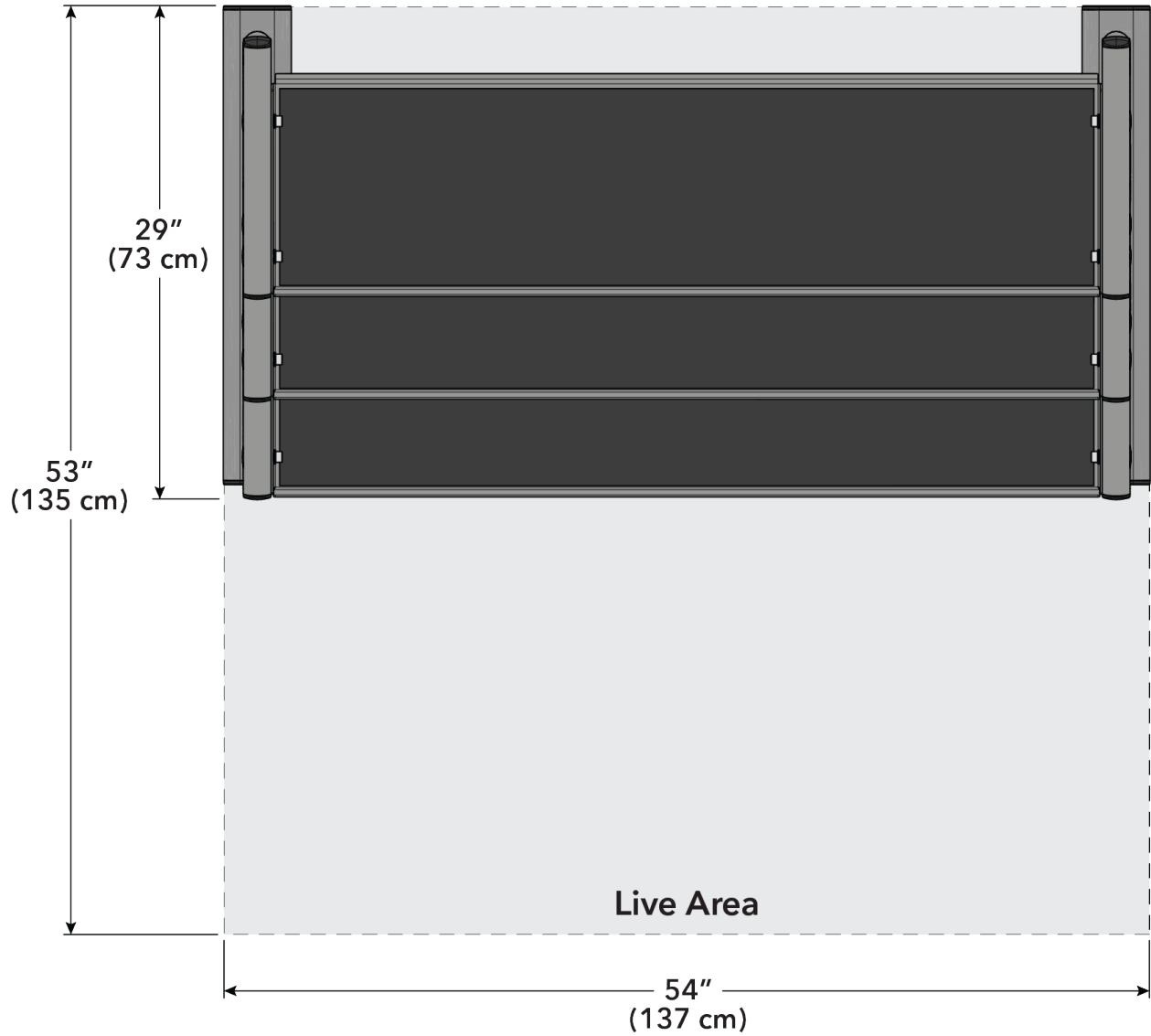

Medicine Ball Storage (LBR-MB)

Machine Weight:	37 lbs.	17 kg.
Size (L x W x H):	in. = 25.5 x 25 x 56	cm = 65 x 63.5 x 142
Live Area (L x W):	in. = 43 x 32	cm = 109 x 81
Storage Weight:	100 lbs.	45 kg.
Max Load:	5 medicine balls at 20 lbs. each	

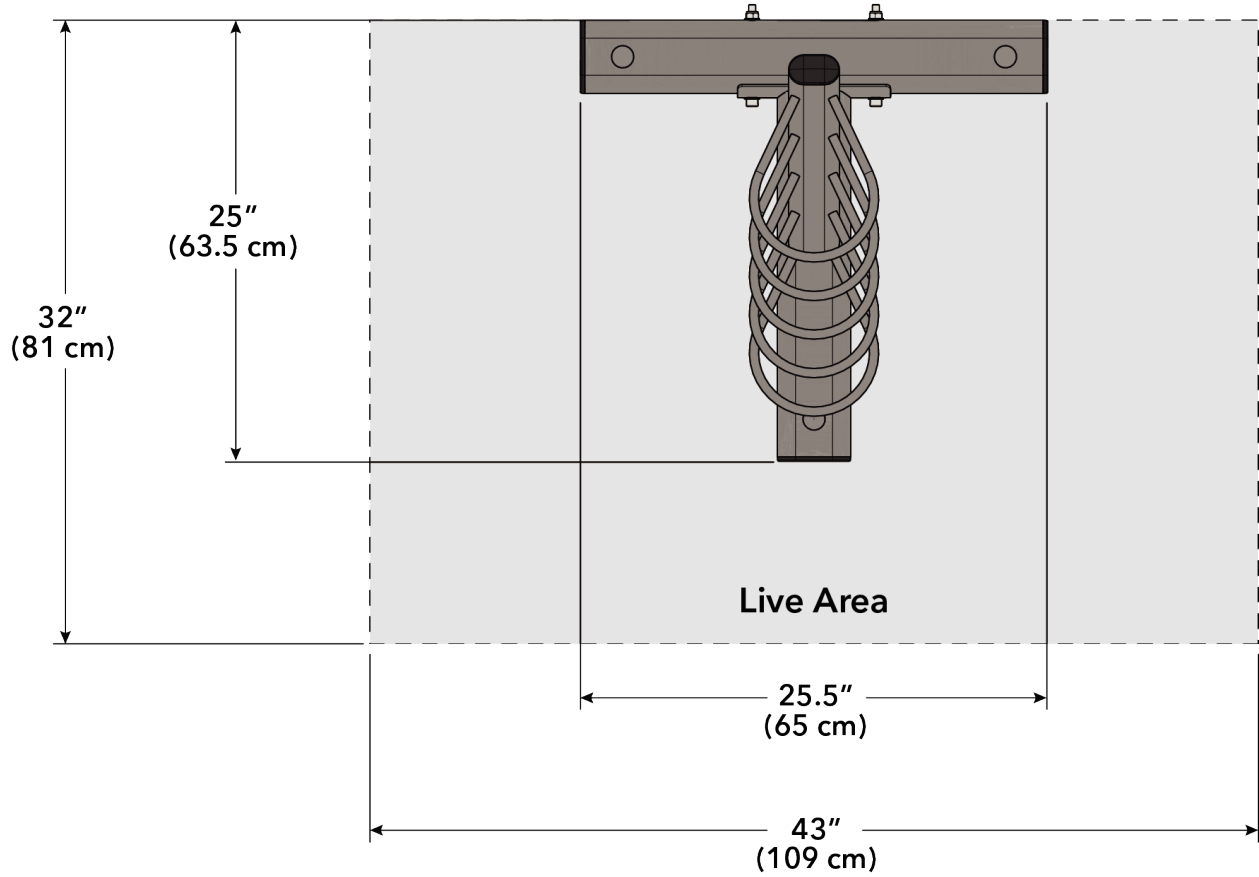

Olympic Squat Rack (LBR-OS)

Machine Weight:	393 lbs.	178 kg.
Size (L x W x H):	in. = 74 x 70 x 75	cm = 188 x 178 x 191
Live Area (L x W):	in. = 116 x 106	cm = 295 x 270
Max User Weight:	300 lbs.	136 kg.

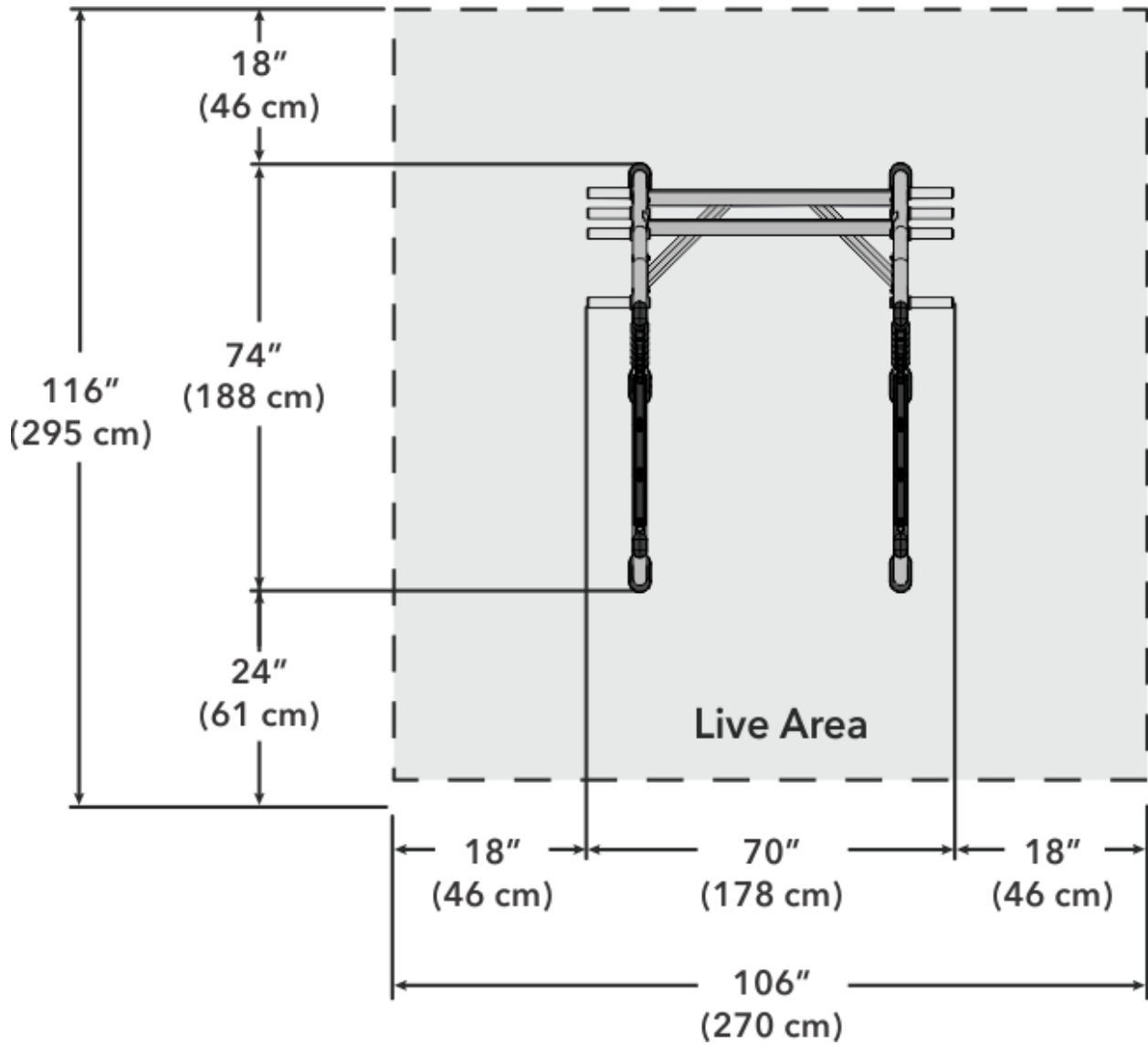

Olympic Weight Tree (LBR-OT)

Machine Weight:	72 lbs.	32.6 kg.
Size (L x W x H):	in. = 27 x 26 x 36	cm = 69 x 66 x 92
Live Area (L x W):	in. = 63 x 62	cm = 160 x 158
Max User Weight:	300 lbs.	136 kg.

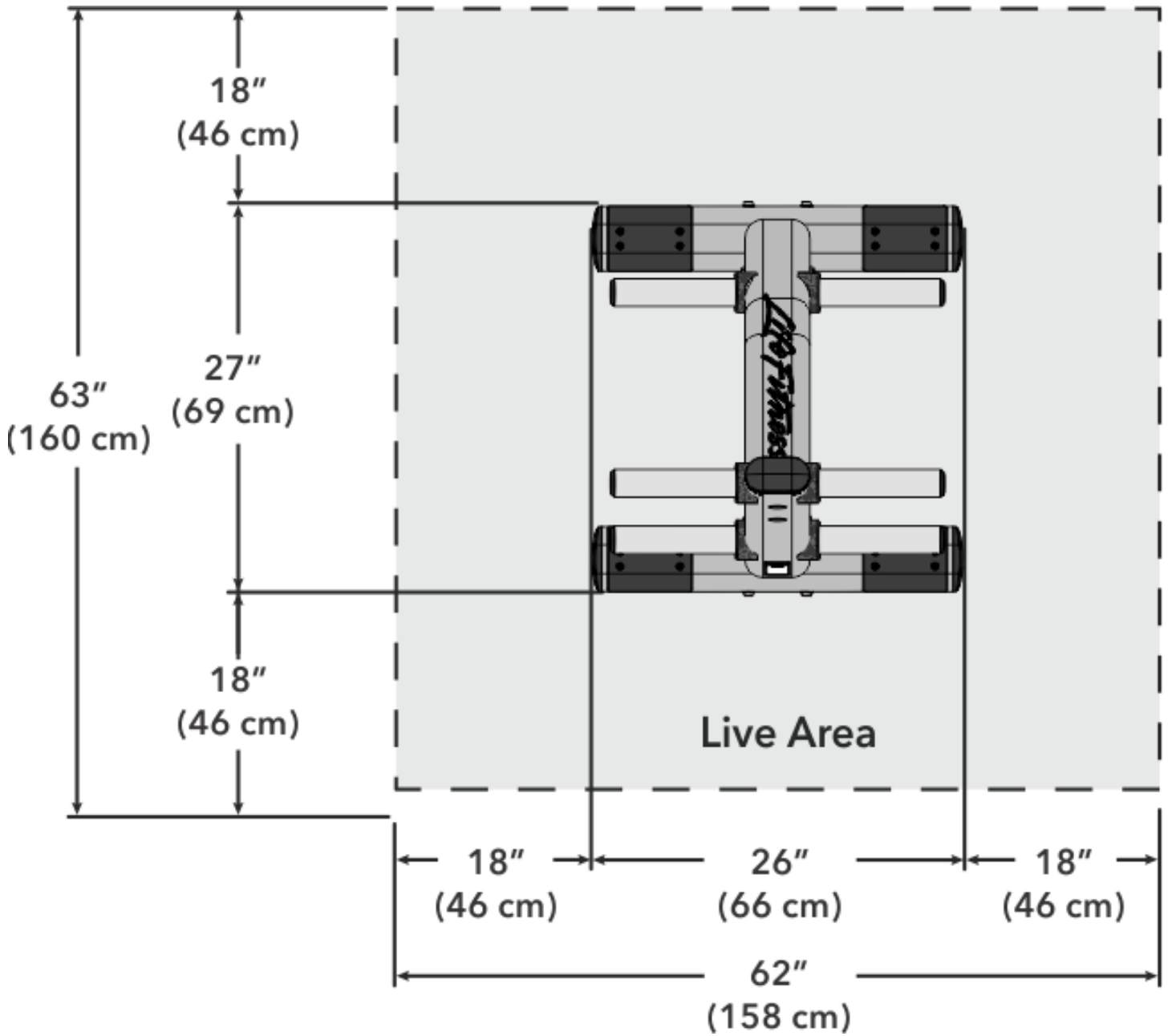

Dumbbell Rack (LBR-DL)

Machine Weight:	286 lbs.	130 kg.
Size (L x W x H):	in. = 97 x 29 x 38	cm = 246 x 73 x 96
Live Area (L x W):	in. = 97 x 53	cm = 246 x 135
Storage Capacity:	650 lbs./tier	295 kg./tier
Max Load:	1 set of 5 lb.-75 lb. dumbbells (1,200 lbs)	

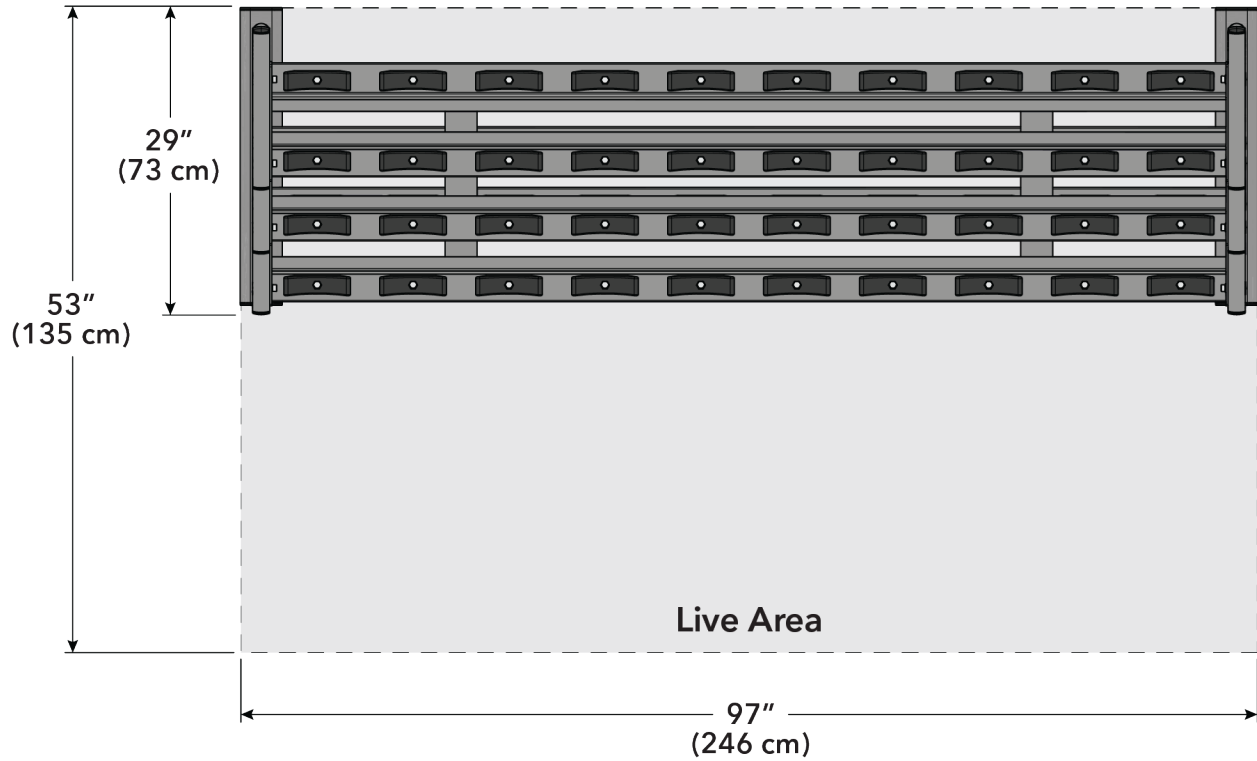

Dumbbell Rack (LBR-DS)

Machine Weight:	200 lbs.	91 kg.
Size (L x W x H):	in. = 61 x 29 x 38	cm = 155 x 73 x 96
Live Area (L x W):	in. = 61 x 53	cm = 155 x 135
Storage Capacity:	270 lbs./tier	120 kg./tier
Max Load:	1 set of 5 lb.-50 lb. dumbbells (550 lbs)	

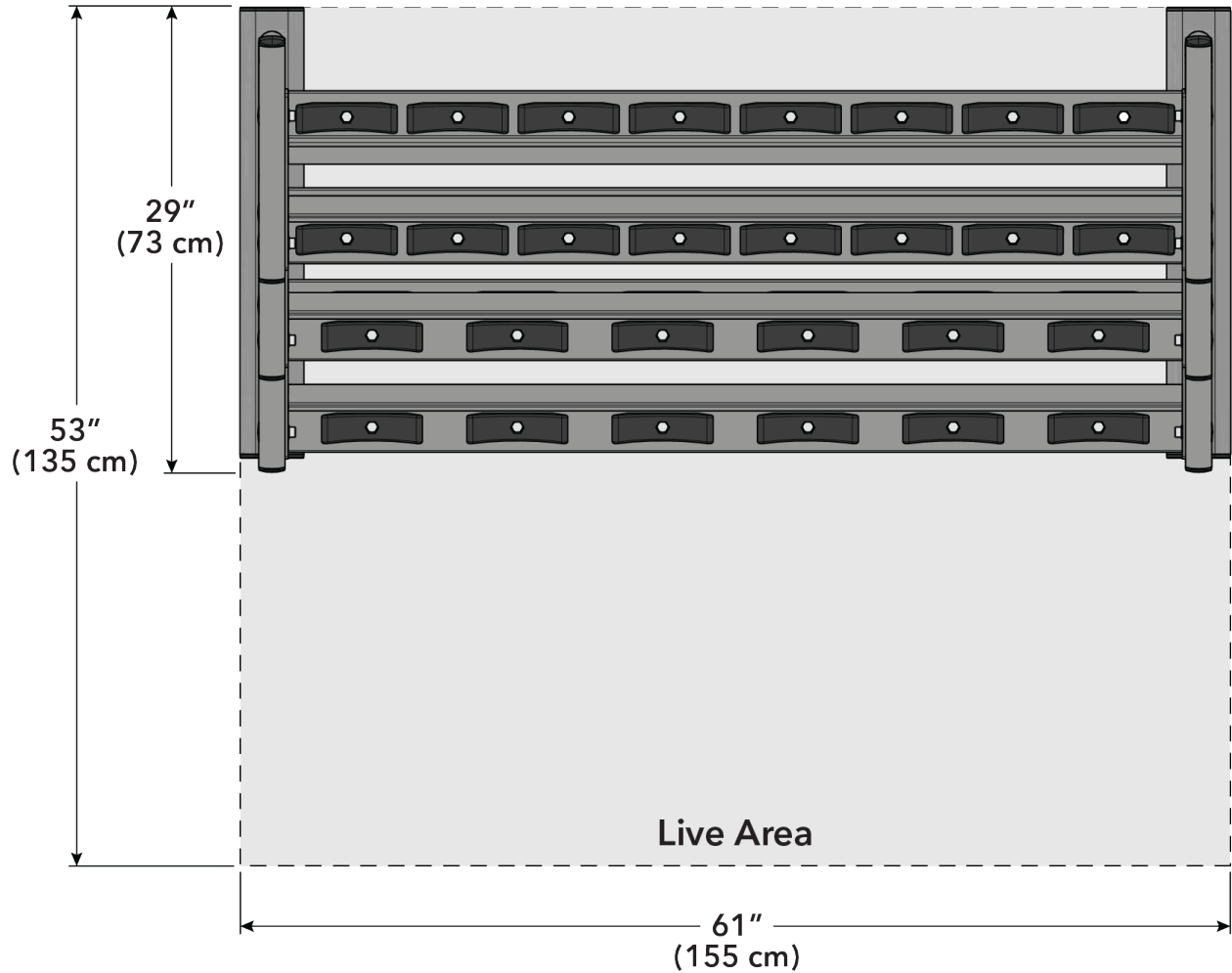

Two Tier Dumbbell Rack (LBR-D2)

Machine Weight:	245 lbs.	111 kg.
Size (L x W x H):	in. = 25 x 90 x 33	cm = 64 x 229 x 84
Live Area (L x W):	in. = 73 x 102	cm = 185 x 259
Max User Weight:	300 lbs.	136 kg.

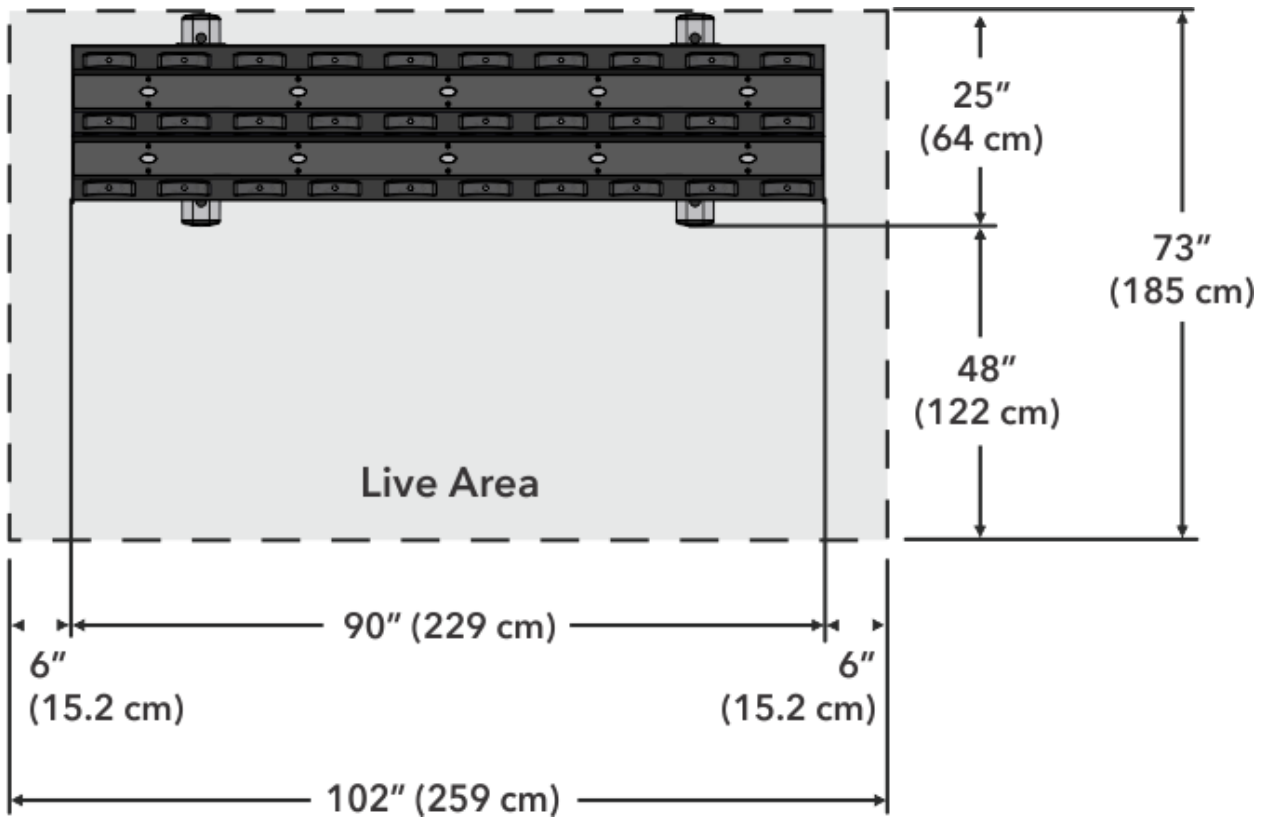

Vertical Dumbbell Rack (LBR-DV)

Machine Weight:	57 lbs.	26 kg.
Size (L x W x H):	in. = 20 x 19 x 46	cm = 50 x 48 x 116
Live Area (L x W):	in. = 44 x 19	cm = 112 x 48
Storage Weight:	180 lbs.	82 kg.
Max Load:	8 pairs of dumbbells, 5-20 lbs.	

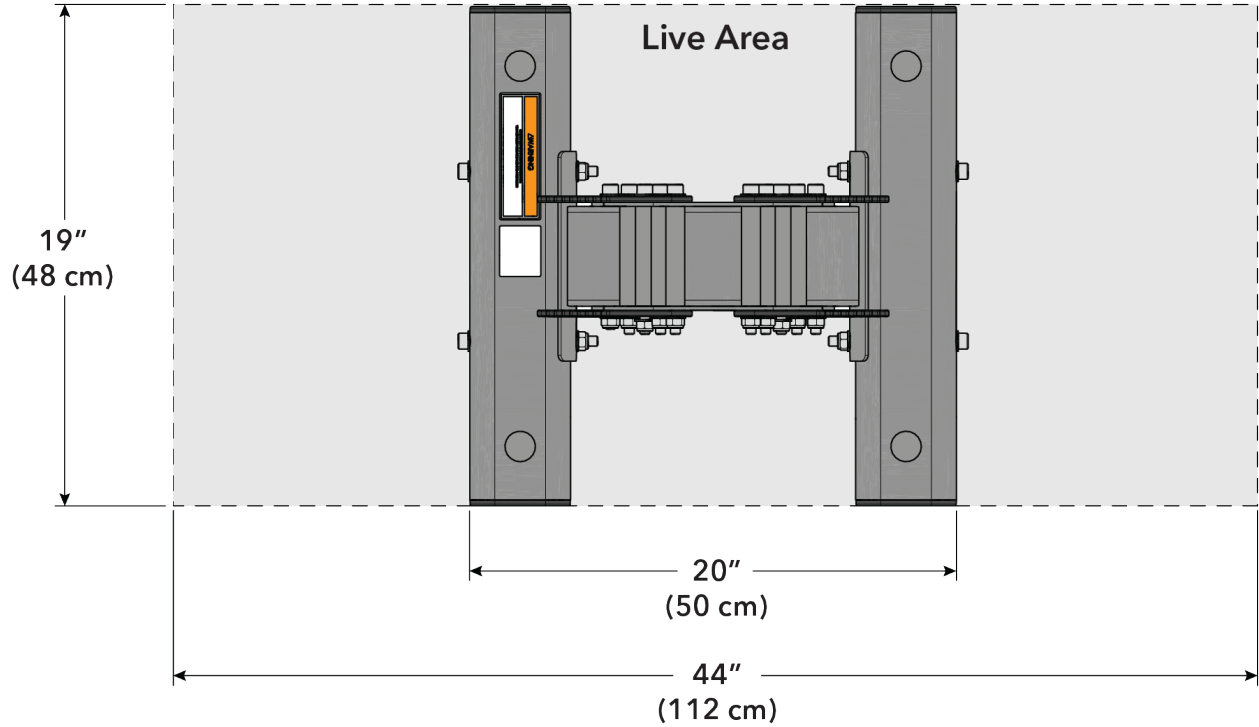

Vertical Dumbbell Rack 10 (LBR-DX)

Machine Weight:	87 lbs.	39.5 kg.
Size (L x W x H):	in. = 21 x 22 x 61	cm = 53.5 x 56 x 155
Live Area (L x W):	in. = 45 x 21	cm = 114.5 x 53.5
Storage Weight:	275 lbs.	125 kg.
Max Load:	10 pairs of dumbbells, 2.5-25 lbs.	

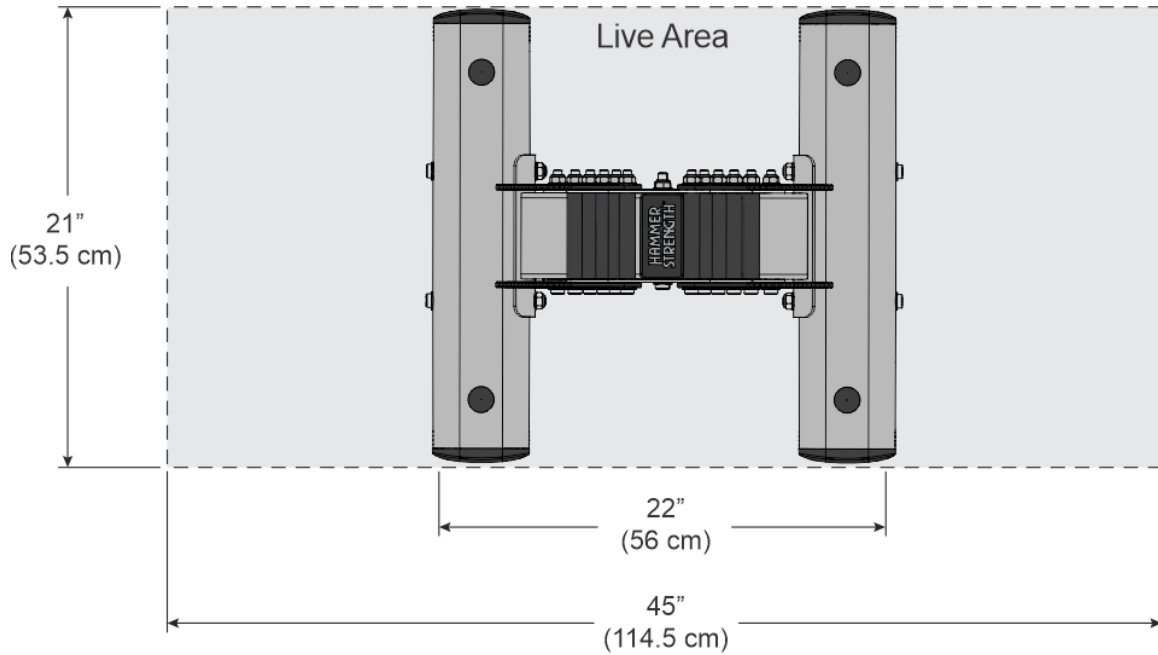

3. Maintenance Procedures

Maintenance Schedule

ACTION	DAILY	WEEKLY	MONTHLY	AS NEEDED
WAX				
Frame				✓
INSPECT				
Frame		✓		
Hardware		✓		
Paint			✓	

Wax

- Frames with a standard, non-abrasive, wax finish.

Inspect

- Hardware. Check for loosening. Tighten as required.
- Frames. Inspect for wear and damage.
- For paint chips. Fill in immediately with manufacturers touch-up paint.

Once a Week

- Visually inspect all hardware for loosening, tampering or wear.

Once a Month

- Inspect hardware on all machines and tighten any bolts or nuts that may have loosened over the life of the product.

Notes

- Use polishing compound (such as car wax) and remove shoe scuffs from powder coated surfaces as necessary.

Approved and Compatible Cleaners

Two preferred cleaners have been approved by reliability experts: PureGreen 24 and Gym Wipes. Both cleaners will safely and effectively remove dirt, grime and sweat from equipment. PureGreen 24 and the Antibacterial Force formula of Gym Wipes are both disinfectants that are effective against MRSA and H1N1.

PureGreen 24 is available in a spray which is convenient to use. Apply the spray to a microfiber cloth and wipe down the equipment. Use PureGreen 24 on the equipment for at least 2 minutes for general disinfection purposes and at least 10 minutes for fungus and viral control.

Gym Wipes are large, durable pre-moistened wipes to use on the equipment before and after workouts. Use Gym Wipes on the equipment for at least 2 minutes for general disinfection purposes.

Contact Customer Support Services to order these cleaners (1-800-351-3737 or email: customersupport@lifefitness.com).

Mild soap and water or a mild non-abrasive household cleaner can also be used to clean the display and all exterior surfaces. Use a soft microfiber cloth only. Apply the cleaner to the microfiber cloth before cleaning. DO NOT use ammonia or acid based cleaners. DO NOT use abrasive cleaners. DO NOT use paper towels. DO NOT apply cleaners directly to the equipment surfaces.

Removal of Paint, Marking Pens, or Labels

- Butyl cellosolve works well for removal of paints, marking pen inks, lipstick, etc.
- Labels, stickers, etc. may be removed using kerosene. When the solvent will not penetrate sticker material, apply heat (hair dryer) to soften the adhesive and promote removal. GASOLINE SHOULD NOT BE USED.

4. Warranty

What is Covered

This Life Fitness commercial exercise equipment product is warranted to be free of all defects in material and workmanship.

Who is Covered

The original purchaser or any person receiving the product as a gift from the original purchaser.

Who Pays Transportation and Insurance For Service

If the Product or any covered part must be returned to a service facility for repairs, We, Life Fitness, will pay all transportation and insurance charges for the first year. You are responsible for transportation and insurance charge after the first year.

What We Will Do To Correct Covered Defects

We will ship to you any new or rebuilt replacement part or component, or at our option, replace the Product. Such replacement parts are warranted for the remaining portion of the original warranty period.

What is Not Covered

Any failures or damage caused by unauthorized service, misuse, accident, negligence, improper assembly or installation, debris resulting from any construction activities in the Product's environment, rust or corrosion as a result of the Product's location, alterations or modifications without our written authorization, or by failure on your part to use, operate and maintain the Product as set out in your Operation Manual.

All terms of this warranty are void if this product is moved beyond the continental borders of the United States of America (excluding Alaska, Hawaii and Canada) and are then subject to the terms provided by that country's local authorized Life Fitness representative.

Owner's Manual

It is VERY IMPORTANT THAT YOU READ THIS MANUAL before operating the Product. Remember to perform the periodic maintenance requirements specified in the Manual to assure proper operation and your continued satisfaction.

Exclusive Warranty

THIS LIMITED WARRANTY IS IN LIEU OF ALL OTHER WARRANTIES OF ANY KIND EITHER EXPRESSED OR IMPLIED, INCLUDING BUT NOT LIMITED TO THE IMPLIED WARRANTIES OF MERCHANTABILITY AND FITNESS FOR A PARTICULAR PURPOSE, AND ALL OTHER OBLIGATIONS OR LIABILITIES ON OUR PART. We neither assume nor authorize any person to assure for us any other obligation or liability concerning the sale of this Product. Under no circumstances shall we be liable under this warranty, or otherwise, of any damage to any person or property, including any lost profits or lost savings, for any special, indirect, secondary, incidental or consequential damages of any nature arising out of the use of or inability to use this Product. Some states do not allow the exclusion or limitation of implied warranties or of liability for incidental or consequential damages, so the above limitations or exclusions may not apply to you. Warranty coverages and terms may differ outside the United States. Please contact the Life Fitness office servicing your country (contact information found at the front of this manual) or visit the applicable local Life Fitness website to receive the specific warranty information for your country.

Changes in Warranty Not Authorized

No one is authorized to change, modify or extend the terms of this limited warranty.

Effects of State Laws

This warranty gives you specific legal rights, and you may have other rights which vary from state to state and country by country.

Terms of Warranty Coverage

Please use the link below to access component warranty terms:





1022961-0001