

# HAMMER STRENGTH®

**HAMMER  
STRENGTH®**

## **HD ELITE RACKS**

Owner's Manual & Assembly Instructions

SINGLE RACKS: HDLASR \* HDLDAP \* HDLHR \* HDLMR \* HDLPR

COMBO RACKS: HDLCR - PR/MR \* HRS \* HRL







M051-00K20-0426

Operation Manuals and other Product Information available at <https://www.lftechsupport.com/web/document-library/documents>

عقودملا ىلع عحاتم زاهجلا ن ع ىرخأ تامول عمو لي غشتلا ةلدأ <https://www.lftechsupport.com/web/document-library/documents>

操作マニュアルおよびその他の製品情報については、<https://www.lftechsupport.com/web/document-library/documents> をご覧ください。

<https://www.lftechsupport.com/web/document-library/documents>

<https://www.lftechsupport.com/web/document-library/documents>

작동 설명서 및 기타 제품 정보는 <https://www.lftechsupport.com/web/document-library/documents> 에서 찾을 수 있습니다.

Trobareu el manual de funcionament i altra informació de producte a <https://www.lftechsupport.com/web/document-library/documents>

Mae Llwylyfrau Gweithredu a Gwybodaeth Arall am Beiriannau ar gael yn <https://www.lftechsupport.com/web/document-library/documents>

Die Betriebsanleitung und andere Produktinformationen erhalten Sie unter <https://www.lftechsupport.com/web/document-library/documents>

Encontrará el manual de funcionamiento y otra información de producto en <https://www.lftechsupport.com/web/document-library/documents>

Erabiltzailearen Eskuliburua eta Beste Produktuei buruzko Informazioa eskuratu <https://www.lftechsupport.com/web/document-library/documents> gunean

Käyttöoppaat ja muut tuotetiedot ovat saatavana osoitteessa <https://www.lftechsupport.com/web/document-library/documents>

Les manuels d'utilisation, ainsi que d'autres informations sur les Produits, sont disponibles sur <https://www.lftechsupport.com/web/document-library/documents>

Felhasználói kézikönyvek és más termékinformációk: <https://www.lftechsupport.com/web/document-library/documents>

Manuali di funzionamento e altre informazioni sui prodotti disponibili su <https://www.lftechsupport.com/web/document-library/documents>

Manuali di funzionamento e altre informazioni sui prodotti disponibili su <https://www.lftechsupport.com/web/document-library/documents>

Instrukcje obsługi i inne informacje o produktach dostępne na stronie <https://www.lftechsupport.com/web/document-library/documents>

Manuais de Operação e Informações sobre outros produtos disponíveis em <https://www.lftechsupport.com/web/document-library/documents>

Руководства по эксплуатации и другую касающуюся нашей продукции информацию можно найти, перейдя по ссылке <https://www.lftechsupport.com/web/document-library/documents>

Kullanım Kılavuzları ve Diğer Ürün Bilgileri <https://www.lftechsupport.com/web/document-library/documents>'da bulunmaktadır

## CORPORATE HEADQUARTERS

Columbia Centre III, 9525 West Bryn Mawr Avenue, Rosemont, Illinois 60018 • U.S.A.

847.288.3300 • FAX: 847.288.3703

Service phone number: 800.351.3737 (toll-free within U.S.A., Canada)

Global Website: [www.lifefitness.com](http://www.lifefitness.com)

## INTERNATIONAL OFFICES

### AMERICAS

#### North America Life Fitness, Inc.

Columbia Centre III  
9525 West Bryn Mawr Avenue  
Rosemont, IL 60018 U.S.A  
Telephone: (847) 288 3300  
Fax: (847) 288 3703  
Service Email:  
[customersupport@lifefitness.com](mailto:customersupport@lifefitness.com)  
Service Website: [www.lifefitness.com/parts](http://www.lifefitness.com/parts)  
Sales/Marketing Email:  
[commercialsales@lifefitness.com](mailto:commercialsales@lifefitness.com)  
Operating Hours: 7:00 am-6:00 pm (CST)

#### Brazil Life Fitness Brasil

Av. Cidade Jardim, 900  
Jd. Paulistano  
São Paulo, SP 01454-000  
BRAZIL  
SAC: 0800 773 8282  
Telephone: +55 (11) 3095 5200  
Fax: +55 (11) 3095 5201  
Service Email: [suporte@lifefitness.com.br](mailto:suporte@lifefitness.com.br)  
Sales/Marketing Email:  
[lifefitness@lifefitness.com.br](mailto:lifefitness@lifefitness.com.br)  
Service Operating Hours:  
9:00 - 17:00 (BRT) (Monday-Friday)  
Store Operating Hours:  
9:00 -20:00 (BRT) (Monday-Friday)  
10:00 - 16:00 (BRT) (Saturday)

#### Latin America & Caribbean\* Life Fitness Inc.

Columbia Centre III  
9525 West Bryn Mawr Avenue  
Rosemont, IL 60018 U.S.A  
Telephone: (847) 288 3300  
Fax: (847) 288 3703  
Service Email:  
[customersupport@lifefitness.com](mailto:customersupport@lifefitness.com)  
Sales/Marketing Email:  
[commercialsales@lifefitness.com](mailto:commercialsales@lifefitness.com)  
Operating Hours: 7:00am-6:00pm (CST)

### EUROPE, MIDDLE EAST, & AFRICA

#### (EMEA)

#### Netherlands & Luxemburg Life Fitness Atlantic BV

Bijdorpplein 25-31  
2992 LB Barendrecht  
THE NETHERLANDS  
Telephone: (+31) 180 646 666  
Fax: (+31) 180 646 699  
Service Email:  
[service.benelux@lifefitness.com](mailto:service.benelux@lifefitness.com)  
Sales/Marketing Email:  
[marketing.benelux@lifefitness.com](mailto:marketing.benelux@lifefitness.com)  
Operating Hours: 9.00h-17.00h (CET)

#### United Kingdom & Ireland Life Fitness UK LTD

Queen Adelaide  
Ely, Cambs, CB7 4UB  
Telephone: General Office (+44)  
1353.666017  
Customer Support (+44) 1353.665507  
Fax: (+44) 1353.666018  
Service Email: [uk.support@lifefitness.com](mailto:uk.support@lifefitness.com)  
Sales/Marketing Email: [life@lifefitness.com](mailto:life@lifefitness.com)  
Operating Hours:  
General Office: 9.00am - 5.00pm (GMT)  
Customer Support: 8.30am - 5.00pm  
(GMT)

#### Germany & Switzerland Life Fitness Europe GMBH

Siemensstraße 3  
85716 Unterschleißheim  
GERMANY  
Telephone: (+49) 89.31 77 51.0 (Germany)  
(+41) 0848 000 901 (Switzerland)  
Fax: (+49) 89.31 77 51.99 (Germany)  
(+41) 043 818 07 20 (Switzerland)  
Service Email:  
[kundendienst@lifefitness.com](mailto:kundendienst@lifefitness.com)  
Sales/Marketing Email:  
[kundenberatung@lifefitness.com](mailto:kundenberatung@lifefitness.com)  
Operating Hours: 08.30 -16.30h (CET)

#### Austria Life Fitness Austria

Vertriebs G.m.b.H.  
Dückerstraße 7-9/3/36  
1220 Vienna  
AUSTRIA  
Telephone: (+43) 1.61.57.198  
Fax: (+43) 1.61.57.198.20  
Service Email: [kundendienst@lifefitness.com](mailto:kundendienst@lifefitness.com)  
Marketing/Sales Email:  
[kundenberatung@lifefitness.com](mailto:kundenberatung@lifefitness.com)  
Operating Hours: 08:30-16.30.h (MEZ)

#### Spain Life Fitness IBERIA

C/Frederic Mompou 5,1ªª  
08960 Sant Just Desvern Barcelona  
SPAIN  
Telephone: (+34) 93.672.4660  
Fax: (+34) 93.672.4670  
Service Email: [servicio.tecnico@lifefitness.com](mailto:servicio.tecnico@lifefitness.com)  
Sales/Marketing Email:  
[info.iberia@lifefitness.com](mailto:info.iberia@lifefitness.com)  
Operating Hours:  
9.00h-18.00h (Monday-Thursday)  
8.30h-15.00h (Friday)

#### Belgium Life Fitness Benelux NV

Parc Industriel de Petit-Rechain  
4800 Verviers  
BELGIUM  
Telephone: (+32) 87 300 942  
Fax: (+32) 87 300 943  
Service Email:  
[service.benelux@lifefitness.com](mailto:service.benelux@lifefitness.com)  
Sales/Marketing Email:  
[marketing.benelux@lifefitness.com](mailto:marketing.benelux@lifefitness.com)  
Operating Hours: 9.00h -17.00h (CET)

#### All Other EMEA Countries & Distributor Business C-EMEA\*

Bijdorpplein 25-31  
2992 LB Barendrecht  
THE NETHERLANDS  
Telephone: (+31) 180 646 644  
Fax: (+31) 180 646 699  
Service Email:  
[service.db.cemea@lifefitness.com](mailto:service.db.cemea@lifefitness.com)  
Sales/Marketing Email:  
[marketing.db.cemea@lifefitness.com](mailto:marketing.db.cemea@lifefitness.com)  
Operating Hours: 9.00h-17.00h (CET)

### ASIA PACIFIC (AP)

#### Japan Life Fitness Japan

Japan Nippon Brunswick Bldg., #8F  
5-27-7 Sendagaya  
Shibuya-Ku, Tokyo  
Japan 151-0051  
Telephone: (+81) 3.3359.4309  
Fax: (+81) 3.3359.4307  
Service Email: [service@lifefitnessjapan.com](mailto:service@lifefitnessjapan.com)  
Sales/Marketing Email:  
[sales@lifefitnessjapan.com](mailto:sales@lifefitnessjapan.com)  
Operating Hours: 9.00h-17.00h (JAPAN)

#### Hong Kong Life Fitness Asia Pacific LTD

32/F, Global Trade Square  
21 Wong Chuk Hang Road  
HONG KONG  
Telephone: (+852) 2575.6262  
Fax: (+852) 2575.6894  
Service Email:  
[HongKongEnquiry@lifefitness.com](mailto:HongKongEnquiry@lifefitness.com)  
Sales/Marketing Email:  
[Marketing.HK.Asia@lifefitness.com](mailto:Marketing.HK.Asia@lifefitness.com)  
Operating Hours: 9.00h-17.00h  
Service Operating Hours: 9.00h-18.00h

#### All Other Asia Pacific countries & distributor business Asia Pacific\* Life Fitness Asia Pacific LTD

32/F, Global Trade Square  
21 Wong Chuk Hang Road  
HONG KONG  
Telephone: (+852) 2575.6262  
Fax: (+852) 2575.6894  
Service Email:  
[HongKongEnquiry@lifefitness.com](mailto:HongKongEnquiry@lifefitness.com)  
Sales/Marketing Email:  
[Marketing.HK.Asia@lifefitness.com](mailto:Marketing.HK.Asia@lifefitness.com)  
Operating Hours: 9.00h-17.00h  
Service Operating Hours: 9.00h-18.00h

\* Also check [www.lifefitness.com](http://www.lifefitness.com) for local representation or distributor/dealer

# TABLE OF CONTENTS

<b>SECTION</b>	<b>DESCRIPTION</b>	<b>PAGE</b>
1	SAFETY INFORMATION .....	3
2	WARRANTY .....	5
3	CONTACT INFORMATION .....	6
4	PRODUCT LABELS .....	7
5	RACK OPTIONS .....	9
6	STORAGE, BASES AND CABLE STATIONS .....	10
7	UPRIGHTS, PULL-UPS AND RACK CONNECTORS .....	11
8	HARDWARE .....	12
9	ASSEMBLY INSTRUCTIONS	
	STORAGE ASSEMBLY .....	13
	BASE ASSEMBLY .....	18
	BENCH ASSEMBLY .....	20
	UPRIGHT ASSEMBLY .....	20
	PULL-UP ASSEMBLY .....	22
	CROSSMEMBER ASSEMBLY .....	24
	RACK CONNECTOR ASSEMBLY .....	26
	ANVIL PLATE ASSEMBLY .....	27
	BAR HANGER ASSEMBLY .....	29
	HANG ACCESSORIES .....	30
	CABLE STATION INSTRUCTIONS .....	31
	WEIGHT STACK ASSEMBLY .....	34
	STORAGE RACK INSTRUCTIONS .....	39
	OPTIONAL EQUIPMENT .....	40
10	CABLE HANDLING GUIDE .....	54
11	BOLT TO FLOOR GUIDE .....	56
12	MAINTENANCE PROCEDURES .....	60

# 1 SAFETY INFORMATION

It is the sole responsibility of the purchaser of HAMMER STRENGTH products to read the owner's manual and warning labels and instruct all individuals, whether they are the end user or supervising personnel, on proper usage of the equipment.

UNDERSTANDING EACH AND EVERY WARNING TO THE FULLEST IS IMPORTANT. IF ANY OF THESE WARNINGS ARE UNCLEAR, CONTACT LIFE FITNESS CUSTOMER SERVICE IMMEDIATELY AT 1-800-735-3867.

This equipment is categorized as class S per EN ISO 20957-1. As such this equipment is only intended for commercial, institutional and/or studio facilities. It is not intended for home use. Contact LIFE FITNESS with any questions regarding this classification.

It is recommended that all users of HAMMER STRENGTH exercise equipment be informed of the following information prior to use.

Health and Environmental Regulations Warning - This product may contain chemicals known to the State of California to cause cancer, birth defects, or other reproductive harm. For more information related to the European Commission Regulation (EC) No. 1907/2006 (REACH) and the California Safe Drinking Water and Toxic Enforcement Act of 1986 (Proposition 65), please visit <https://www.lftechsupport.com/web/guest/environmentalregulations-information>.

## ACCESS CONTROL

HAMMER STRENGTH recommends that all commercial fitness equipment be used in a supervised area. It is recommended that the equipment be located in an access controlled area. Control is the responsibility of the facility owner.

This equipment is not intended for use by children. Keep children under the age of 13 away from the equipment.

## INSTALLATION

SECURING EQUIPMENT - HAMMER STRENGTH recommends that all equipment be secured to a solid, level surface to stabilize it and eliminate rocking or tipping over. This must be performed by a licensed contractor.

## PROPER USAGE

1. Do not use any equipment in any way other than designed or intended by the manufacturer. It is imperative that HAMMER STRENGTH equipment is used properly to avoid injury.
2. Injuries may result if exercising improperly or excessively. It is recommended that all individuals consult a physician prior to commencing an exercise program. If at any time during exercise you feel faint, dizzy or experience pain, STOP EXERCISING and consult your physician.
3. Keep body parts (hands, feet, hair, etc.), clothing and jewelry away from moving parts to avoid injury.
4. When adjusting any seat, knee hold down pad, range of motion limiter, foothold pad, pulley or any other type of adjuster, make certain that the adjusting pin is fully engaged in the hole to avoid injury.

## INSPECTION

1. DO NOT use or permit use of any equipment that is damaged and/or has worn or broken parts. For all HAMMER STRENGTH equipment use only replacement parts supplied by HAMMER STRENGTH.
2. Cables pose an extreme liability if used when frayed. Always replace any cable at first sign of wear (consult LIFE FITNESS if uncertain).
3. MAINTAIN LABELS AND NAME PLATES - Do not remove labels for any reason. They contain important information. If unreadable or missing, contact LIFE FITNESS for a replacement.

## **INSPECTION** (CONTINUED)

5. EQUIPMENT MAINTENANCE - Preventative maintenance is the key to smooth operating equipment as well as to keep your liability to a minimum. Equipment needs to be inspected at regular intervals.
6. Ensure that any person(s) making adjustments or performing maintenance or repair of any kind is qualified to do so. LIFE FITNESS will provide service and maintenance training at our corporate facility upon request or in the field if proper arrangements are made.
7. Before any use, examine all accessories approved for use with the HAMMER STRENGTH equipment for damage or wear.
8. DO NOT ATTEMPT TO USE OR REPAIR ANY ACCESSORY APPROVED FOR USE WITH THE HAMMER STRENGTH EQUIPMENT WHICH APPEARS TO BE DAMAGED OR WORN.

## **OPERATING WARNINGS**

1. It is the purchaser's sole responsibility to properly instruct its end users and supervising personnel as to the proper operating procedures of all HAMMER STRENGTH equipment.
2. Keep children away from strength equipment. Parents or others supervising children must provide close supervision of children if the equipment is used in the presence of children.
3. Do not allow users to wear loose fitting clothing or jewelry while using equipment. It is also recommended to have users secure long hair back and up to avoid contact with moving parts.
4. All bystanders must stay clear of all users, moving parts and attached accessories and components while machine is in operation.

## **PLATE LOADED, FREE WEIGHT AND BODY WEIGHT SYSTEMS**

1. If the unit is equipped with weight rods, use only Olympic style weight plates (2.0" bore) for training weight. Do not use dumbbells or any means other than those stated to increase weight resistance - See machine specific section for more information.
2. Always utilize weight plate retention devices such as clamps or pins.
3. Only add weight plates up to the load limits of the unit. Make sure all weight plates are completely placed on the weight rod.
4. Never exceed the load rating for any plate loaded station, body weight station, bench or other free weight device; including specific weight rod and band peg limits. See machine specific section for load limit information.
5. Contact a Life Fitness representative with any questions regarding proper weights and loading.

## **SELECTORIZED WEIGHT STACK SYSTEMS**

1. Use only weight selector pins supplied by HAMMER STRENGTH on weight stacks. Substitutes are forbidden.
2. Fully insert weight selector pins. Partial insertion can cause weights to fall unexpectedly.
3. Never pin the weight stack in an elevated position.
4. Never remove selector pin if any weights are suspended.
5. Never attempt to release jammed weights or parts.
6. Never use dumbbells or other means to incrementally increase the weight resistance. Use only those means provided by HAMMER STRENGTH.

# 2 WARRANTY

## WHAT IS COVERED

This Hammer Strength commercial exercise equipment (Product) is warranted to be free of all defects in material and workmanship.

## WHO IS COVERED

The original purchaser or any person receiving the product as a gift from the original purchaser.

## WHO PAYS TRANSPORTATION & INSURANCE FOR SERVICE

If the Product or any covered part must be returned to a service facility for repairs, We, Life Fitness, will pay all transportation and insurance charges for the first year. You are responsible for transportation and insurance charge after the first year.

## WHAT WE WILL DO TO CORRECT COVERED DEFECTS

We will ship to you any new or rebuilt replacement part or component, or at our option, replace the Product. Such replacement parts are warranted for the remaining portion of the original warranty period.

## WHAT IS NOT COVERED

Any failures or damage caused by unauthorized service, misuse, accident, negligence, improper assembly or installation, debris resulting from any construction activities in the Product's environment, rust or corrosion as a result of the Product's location, alterations or modifications without our written authorization, or by failure on your part to use, operate and maintain the Product as set out in you Operation Manual (.Manual.).

*All terms of this warranty are void if this product is moved beyond the continental borders of the United States of America (excluding Alaska, Hawaii and Canada) and are then subject to the terms provided by that country's local authorized Life Fitness representative.*

## OPERATION MANUAL

It is VERY IMPORTANT THAT YOU READ THIS MANUAL before operating the Product. Remember to perform the periodic maintenance requirements specified in the Manual to assure proper operation and your continued satisfaction.

## EXCLUSIVE WARRANTY

THIS LIMITED WARRANTY IS IN LIEU OF ALL OTHER WARRANTIES OF ANY KIND EITHER EXPRESSED OR IMPLIED, INCLUDING BUT NOT LIMITED TO THE IMPLIED WARRANTIES OF MERCHANTABILITY AND FITNESS FOR A PARTICULAR PURPOSE, AND ALL OTHER OBLIGATIONS OR LIABILITIES ON OUR PART. We neither assume nor authorize any person to assure for us any other obligation or liability concerning the sale of this Product. Under no circumstances shall we be liable under this warranty, or otherwise, of any damage to any person or property, including any lost profits or lost savings, for any special, indirect, secondary, incidental or consequential damages of any nature arising out of the use of or inability to use this Product. Some states do not allow the exclusion or limitation of implied warranties or of liability for incidental or consequential damages, so the above limitations or exclusions may not apply to you.

## CHANGES IN WARRANTY NOT AUTHORIZED

No one is authorized to change, modify or extend the terms of this limited warranty.

## EFFECTS OF STATE LAWS

This warranty gives you specific legal rights, and you may have other rights which vary from state to state.

## OUR PLEDGE TO YOU

We want you to be completely satisfied with our Products and will do everything possible under the terms of this warranty to keep you secure in knowing you have bought the best!

## HOW TO OBTAIN PARTS & SERVICE

1. Verify the symptom and review the operating instructions. The problem may be unfamiliarity with the product and its features and workouts.
2. Locate and write down the serial number of the unit.
3. Contact the nearest Life Fitness Customer Support Services Group.

## WARRANTY COVERAGE

\* *There is no warranty coverage for labor on Strength Products.*

Frame	Pillow Blocks	Pulleys	Weight Plates	Guide Rods	Belts / Springs	Grips	Upholstery	Bearings	Hardware / Mechanical
10 Years	5 Years	5 Years	5 Years	5 Years	90 Days	1 Year	90 Days	1 Year	90 Days

# 3 CONTACT INFORMATION

## For Product Service within the United States and Canada:

Toll-free: 800-735-3867

Please call Monday through Friday from 7:00 a.m. to 6:00 p.m. Central Standard Time, and tell them your name, address, and serial number of your Product. They will tell you how to get a replacement part, or if necessary, arrange for service where your Product is located or advise you on how and where to ship the Product for service. Before shipping:

1. Obtain a Return Authorization Number (RA#) from Customer Support Services.
2. Securely pack your Product (use the original shipping carton, if possible).
3. Write the RA# on the outside of the carton.
4. Insure the Product.
5. Include a letter explaining the defect or problem and a copy of your proof of purchase if you believe the service is covered by warranty.

## Return address:

Life Fitness World Headquarters  
Attn: CSS Help Desk  
Columbia Centre III,  
9525 West Bryn Mawr Avenue,  
Rosemont, Illinois 60018

For Product Service Internationally see contact information listed on page one of this manual.

# 4 PRODUCT LABELS

ITEM NO.	DESCRIPTION	LOCATION
1	BAR CATCH WARNING	UPRIGHTS - MID
2	FOLLOW PRECAUTIONS	STORAGE - MID
3	FOLLOW PRECAUTIONS (2)	STORAGE - MID
4	BODY WEIGHT STRAP WARNING	STORAGE - MID
5	NOT ASSEMBLED	UPRIGHTS - TOP
6	SERIAL NUMBER	BASE WELDMENT

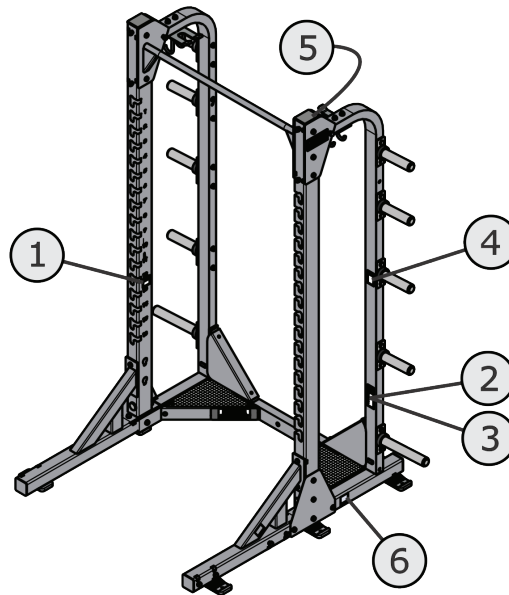

**1**

**⚠ WARNING**

TO REDUCE THE RISK OF SERIOUS INJURY ALWAYS place bar catches at or above this level while performing squat exercises.

← →

ALWAYS use bar catches while using this machine.

**2**

**⚠ WARNING**

SERIOUS INJURY CAN OCCUR ON THIS EQUIPMENT. YOU MUST FOLLOW THESE PRECAUTIONS TO AVOID INJURY!

1. Before using, read all the warnings and obtain instruction on the use of this machine. Use only for intended exercise. **DO NOT** modify the machine.
2. Obtain a medical exam before beginning any exercise program.
3. Keep body, hair and clothing free of all moving objects.
4. Inspect the machines before use. **DO NOT** use if it appears damaged. **DO NOT** attempt to fix a broken or jammed machine. Notify staff immediately.
5. Children must not be allowed near this machine. Supervise teenagers.
6. Manufacturer recommends that all equipment be secured to the floor to stabilize and eliminate rocking or tipping over. Use a licensed contractor.
7. **DO NOT REMOVE THIS LABEL. REPLACE IF DAMAGED.** 8926501

**3**

**⚠ WARNING**

SERIOUS INJURY CAN OCCUR ON THIS EQUIPMENT. YOU MUST FOLLOW THESE PRECAUTIONS TO AVOID INJURY!

1. Before using, read all the warnings and obtain instruction on the use of this machine. Use only for intended exercise. **DO NOT** modify the machine.
2. Obtain a medical exam before beginning any exercise program.
3. Keep body, hair and clothing free of all moving objects.
4. Inspect the machines before use. **DO NOT** use if it appears damaged. **DO NOT** attempt to fix a broken or jammed machine. Notify staff immediately.
5. Be certain that weight pin is completely inserted. Use only the pin provided by the manufacturer. If unsure, seek assistance.
6. Never pin the weights or prop plates into an elevated position. **DO NOT** use the machine if found in this condition. **DO NOT** attempt to fix. Seek assistance.
7. Inspect cables and their connections before using machine. **DO NOT** attempt to fix. Seek assistance.
8. Use only the incremental weights supplied by the manufacturer. **DO NOT** use dumbbells or other means to add resistance to the machine.
9. Children must not be allowed near this machine. Supervise teenagers.
10. **DO NOT REMOVE THIS LABEL. REPLACE IF DAMAGED.**

**4**

**⚠ WARNING**

SERIOUS INJURY CAN OCCUR ON THIS EQUIPMENT. YOU MUST FOLLOW THIS PRECAUTION TO AVOID INJURY!

**DO NOT USE** any body weight strap training devices with this equipment unless the equipment is secured to the floor.

Contact LIFE FITNESS with questions.

**5**

**⚠ WARNING**

This equipment is not fully assembled.

**DO NOT USE.**

**6**

**HAMMER STRENGTH**

Machine #  
Model #  
Serial #

# 4 PRODUCT LABELS

ITEM NO.	DESCRIPTION	LOCATION
1	MAX CAPACITY - 200LB	UPPER BAND PEGS
2	MAX CAPACITY - 485LB	TECHNIQUE TRAYS, STEP UP
3	MOVING PARTS	PINCH POINTS
4	CAUTION: ADJUST	ACCESSORY ANVIL PLATES
5	DO NOT OFFSET	FLEXIBLE PR STRAPS
6	CABLE INSPECT	CABLES

**1**

**⚠ WARNING**

Maximum capacity 200 lbs (90.7 kg)  
DO NOT EXCEED

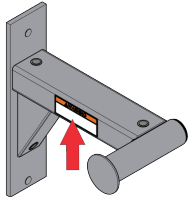

**2**

**⚠ WARNING**

Maximum capacity 485 lbs (220.0 kg)  
DO NOT EXCEED.

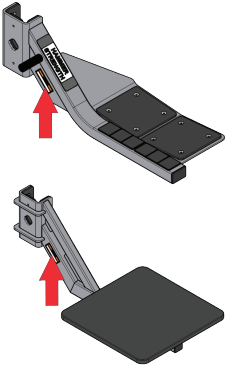

**3**

**⚠**

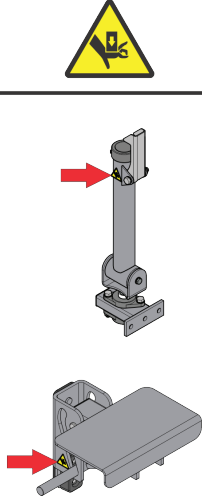

**4**

**⚠ CAUTION**

Failure to correctly adjust could result in personal injury.  
Always fully engage the detent pin before use to avoid injury.

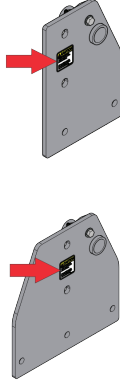

**5**

**⚠ WARNING**

If you choose to offset adjustment straps, DO NOT offset more than 3 hole positions.

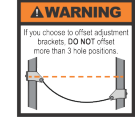
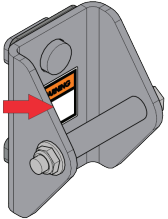
**6**



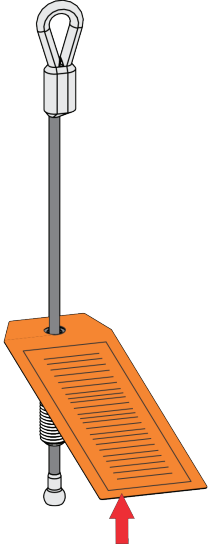

# 5 RACK OPTIONS/ACCESSORIES

	Name	ProductCode	HalfRack	HalfRack	Multi	Power	CableStations
			ShortBase	LongBase	Rack	Rack	
			HDLHRS	HDLHRL	HDLMR	HDLPR	HDLCRDAP HDL LLD.PD.HDLROW
Pull-Up	2-HandlePull-Up	HDL2PU	X	X	X	X	X
	ArcDualPull-Up	HDLARC	X	X	X	X	X
	Thick(2)GripPull-Up	HDLTPU	X	X	X	X	X
	DualPull-Up	HDLDPU	X	X	X	X	X
	StraightBarPull-Up(standard)	HDLSPU	X	X	X	X	X
	ThickStraightBarPull-Up	HDLTSPU	X	X	X	X	X
	Neutral(1.25)Pull-Up	HDLNPU	X	X	X	X	X
	Thick(2)NeutralPull-Up	HDLTNPU	X	X	X	X	X
	RotatingChin-UpHandles	HDLRCU	X	X	X	X	X
	3-HandlePull-Up	HDL3PU-PR	NA	NA	NA	X	NA
	Wing	HDLWG-PR	NA	NA	NA	X	NA
	Base	StandardBase	Onlyavailableat initialorder.	X	X	X	X
StandardBasewithSidePullUp		Onlyavailableat initialorder.	NA	NA	NA	X	NA
SumoBase		Onlyavailableat initialorder.	NA	NA	X	X	NA
Band Pegs	StandardBasePerpendicularBandPegs	HDLBPB-PR	NA	NA	X	X	NA
	BottomSlidingBandPegs	HDL SBP	X	NA	X	X	NA
	BottomSlidingBandPegs-HalfRackLong Base	HDL SBP-HRL	NA	X	NA	NA	NA
	TopBandPegs	HDLTBP	X	X	X	X	NA
	SumoBasePerpendicularBandPegs	HDLPSBP-PR	NA	NA	X	X	NA
Other	PowerPivot	HDLPP	X	X	X	X	NA
	BattleRopeAttachment	HDLBL	X	X	X	X	NA
	HalfRackBarCatchStorage	HDLBCS-HR	X	X	NA	NA	NA
	SpotterPlatforms	HDLSP	X	X	X	X	NA
	ReverseBarSupports	HDLRBS	NA	NA	X	X	NA
	Dock'NLockSystem	HDLDL	X	X	X	X	NA
	4BarStorage	HDL4BS	X	X	X	X	NA
	SingleLegSquatBar	HDL SLS	X	X	X	X	NA
	ThickBarHanger(orderedindividually)	HDLTBH	StandAloneStoragesacceptupto2 ComboStorages(Short,Medium,&Long)acceptupto4				

## HDELITEACCESSORYPRODUCTS

Dip Handles	DipHandle-HalfRack	HDLDIP-HR	X	X	NA	NA	NA
	DipHandle-PowerRack/MultiRack	HDLDIP-PRMR	NA	NA	X	X	NA
Technique Trays	TechniqueTrays-HalfRack	HDLTT-HR	X	X	NA	NA	NA
	TechniqueTrays-PowerRack/MultiRack	HDLTT-PRMR	NA	NA	X	X	NA
Step Platform	StepPlatform-HalfRack	HDLSTP-HR	X	X	NA	NA	NA
	StepPlatform-PowerRack/MultiRack	HDLSTP-PRMR	NA	NA	X	X	NA
	NordicHam	HDL-NH	X	X	X	X	NA
	Acc.AnvilPlate-ShortBase	HDL-ANVL-SB	X	NA	NA	X	NA
	Acc.AnvilPlate-LongBase	HDL-ANVL-LB	NA	X	X	X	NA
	FlexBarCatch	HDL-FBC	NA	NA	NA	X	NA
	RopePull	HDLRP	X	X	NA	X	NA
	CustomBrandingSign	HDLCS	X	X	X	X	NA
	BallStorageWeldment	HDLTBS	X	X	X	X	NA
	SafetySquatHandles	HDL-SSH	X	X	X	X	NA

# 6 STORAGE, BASES AND CABLE STATIONS

## STORAGE

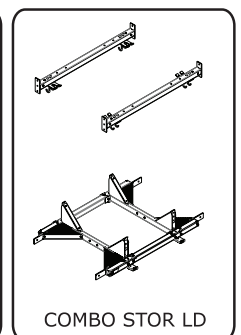
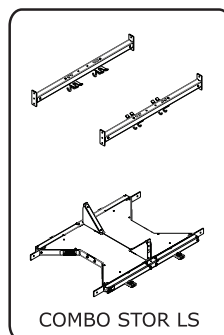
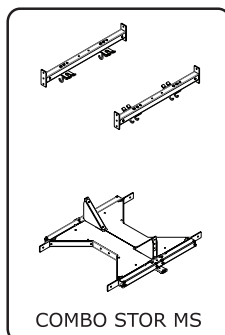
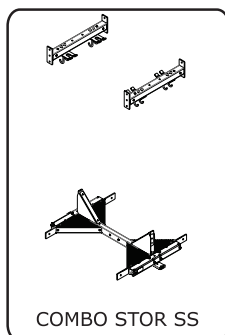
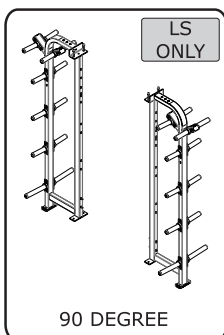
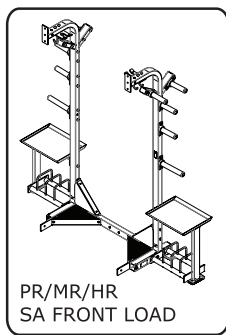
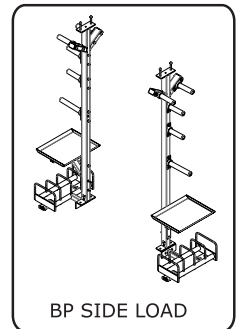
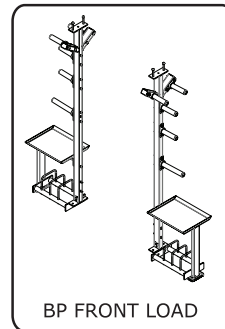
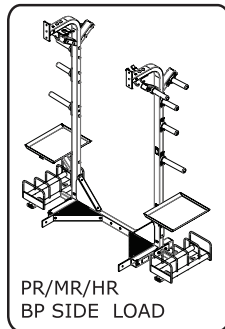
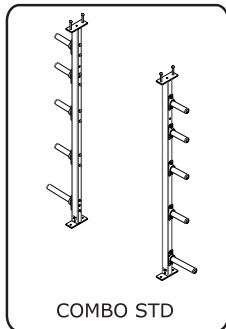
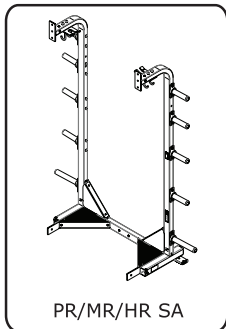

## BASES

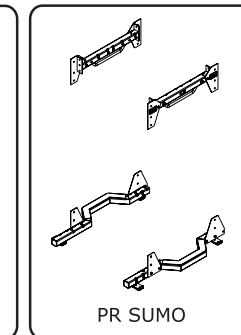
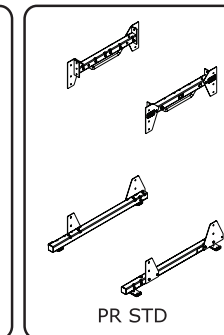
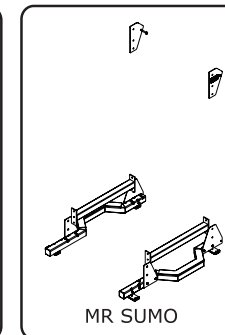
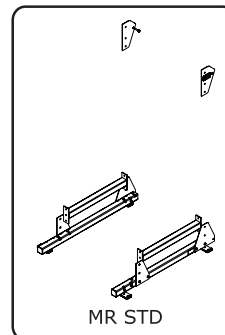
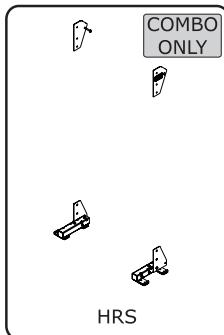
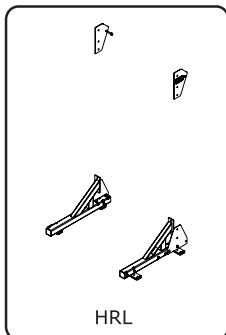

## CABLE STATIONS

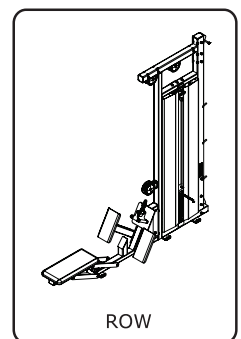
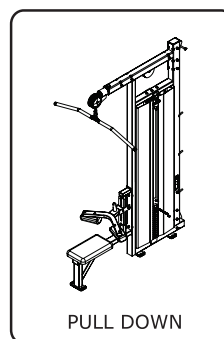
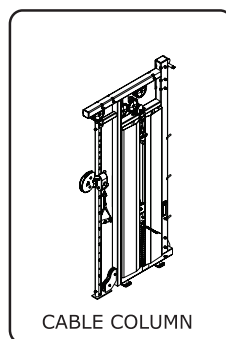
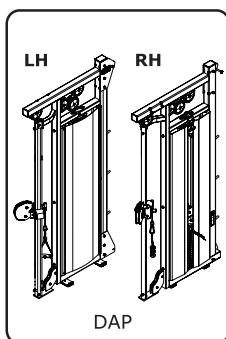

# 7 UPRIGHTS, PULL-UP BARS AND RACK CONNECTORS

## UPRIGHTS

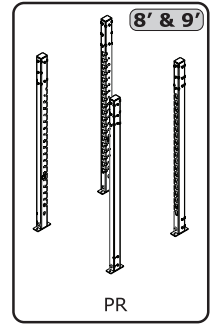
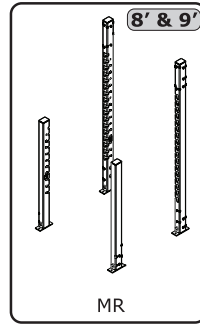
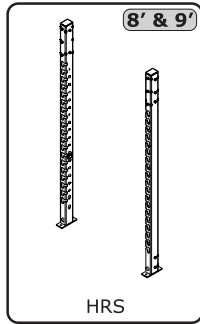
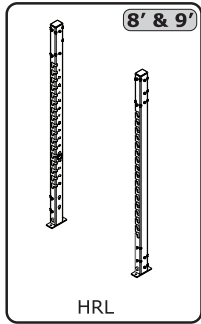

## PULL-UP BARS

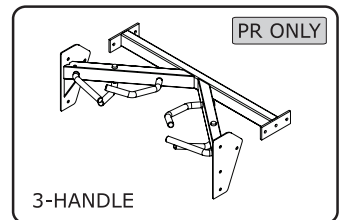
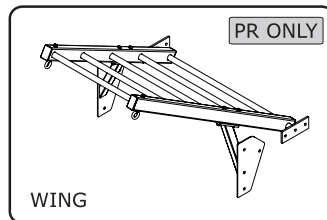
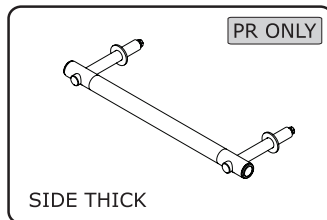
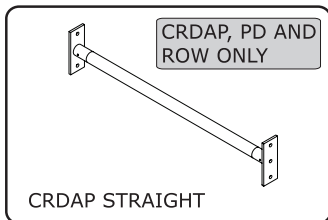
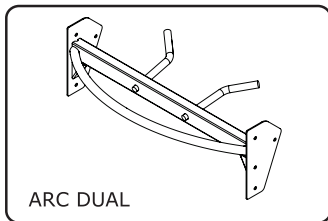
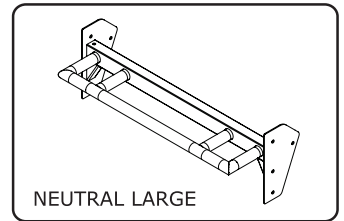
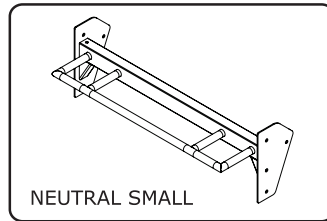
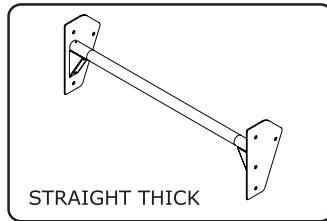
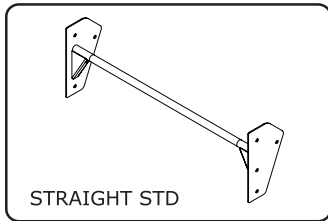
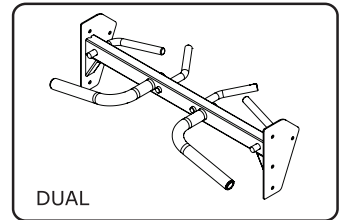
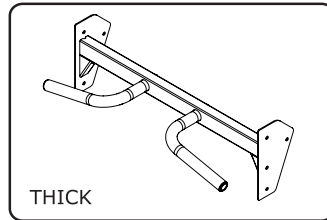
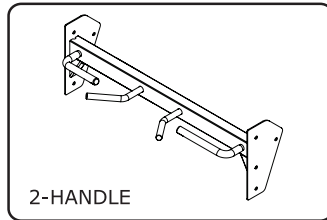
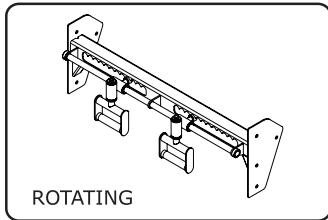

## RACK CONNECTORS

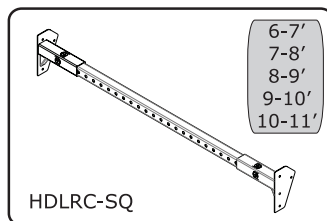
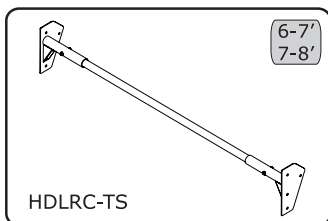

# 8 HARDWARE

**A** 3" RECTANGLE TUBING NUT

**B** 4" RECTANGLE TUBING NUT

**C** 1/4" X 3/4" BUTTON HEAD SOCKET SCREW

**D** 1/2" X 1-1/4" HEX HEAD BOLT

**E** 1/2" X 3" HEX HEAD BOLT

**F** 1/2" X 4" HEX HEAD BOLT

**G** 1/2" X 4" HEX HEAD BOLT W/NYLOCK PATCH

**H** 1/2" LOCK WASHER

**I** 1/2" THIN LOCK NUT

**J** SPACER (USED ON 9' UPRIGHTS)

**K** FENDER WASHER

**L** 1/2" X 3-1/2" HEX HEAD BOLT

**M** 1/2" THICK LOCK NUT

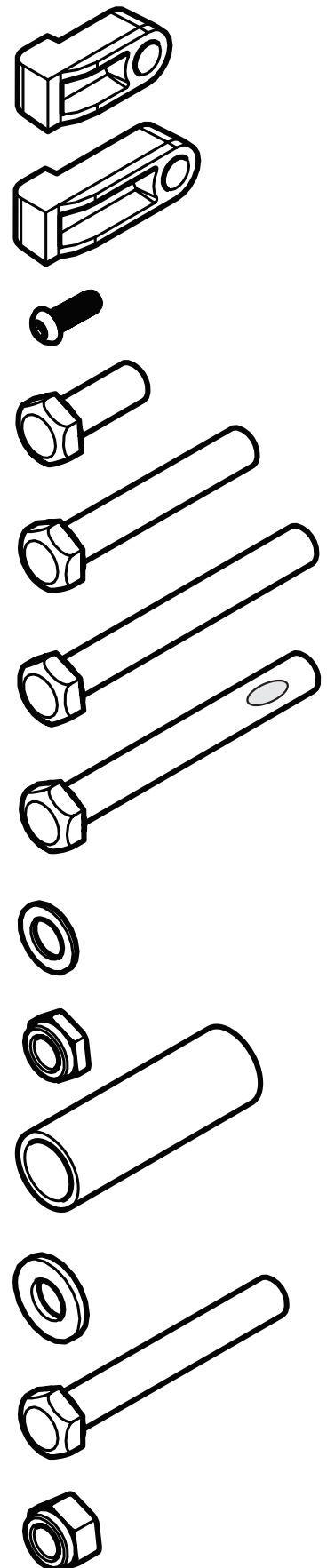

# 9 ASSEMBLY INSTRUCTIONS

## STORAGE ASSEMBLY

### HR/MR/PR

ITEM	QTY.	DESCRIPTION
<b>C</b>	10	1/4" X 3/4" BUTTON HEAD SOCKET SCREW
<b>1</b>	2	GUSSET COVER
<b>2</b>	1	SPIDER WELDMENT
<b>3</b>	2	DIAMOND PLATE

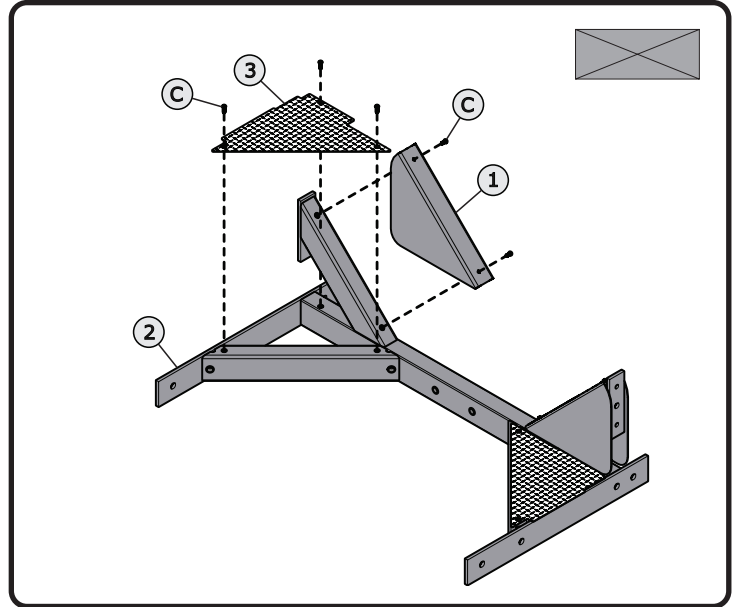

### COMBO

SS

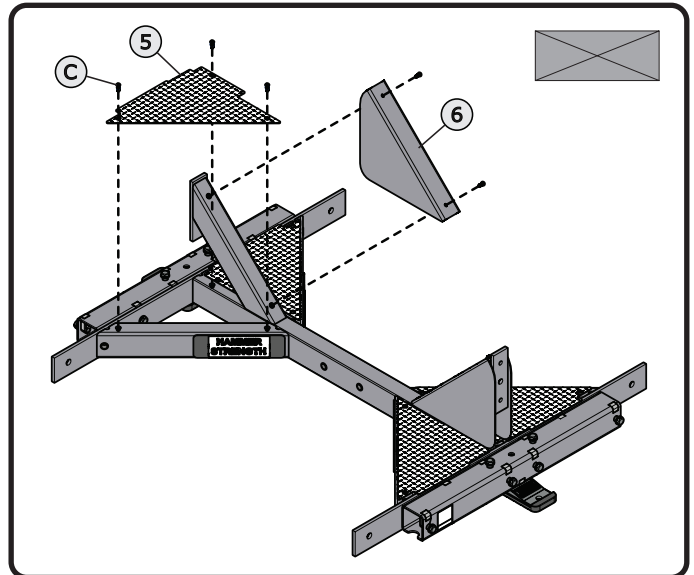
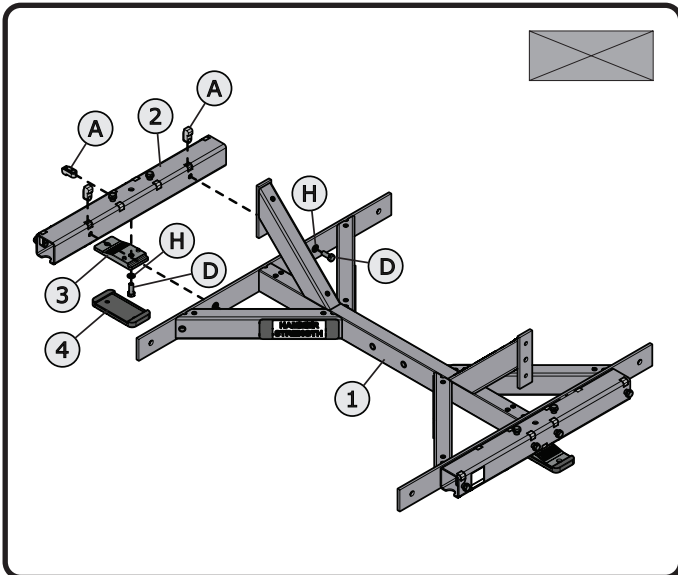

ITEM	QTY.	DESCRIPTION	ITEM	QTY.	DESCRIPTION
<b>A</b>	6	3" RECTANGLE TUBING NUT	<b>2</b>	2	BASE WELDMENT
<b>C</b>	10	1/4" X 3/4" BUTTON HEAD SOCKET SCREW	<b>3</b>	2	HDL FOOT
<b>D</b>	6	1/2" X 1-1/4" HEX HEAD BOLT	<b>4</b>	2	RUBBER SLIPPER
<b>H</b>	6	1/2" LOCK WASHER	<b>5</b>	4	DIAMOND PLATE
<b>1</b>	1	SPIDER WELDMENT	<b>6</b>	2	GUSSET COVER

# COMBO

## MS/LS

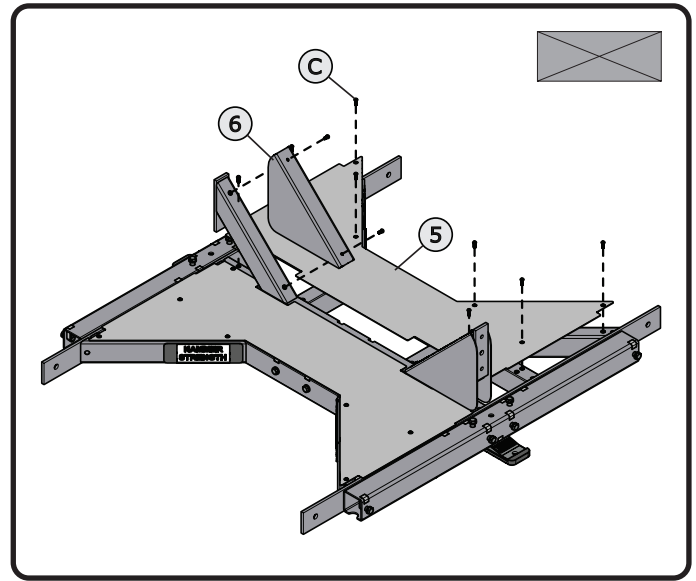
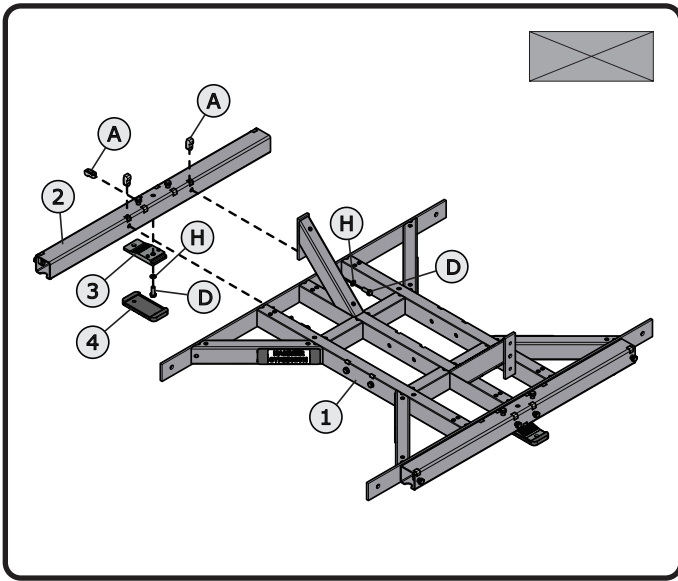

ITEM	QTY.	DESCRIPTION	ITEM	QTY.	DESCRIPTION
A	6	3" RECTANGLE TUBING NUT	2	2	BASE WELDMENT
C	18	1/4" X 3/4" BUTTON HEAD SOCKET SCREW	3	2	HDL FOOT
D	6	1/2" X 1-1/4" HEX HEAD BOLT	4	2	RUBBER SLIPPER
H	6	1/2" LOCK WASHER	5	2	MS DIAMOND PLATE
1	1	MS SPIDER WELDMENT (LS NOT SHOWN)	6	2	GUSSET COVER

# COMBO

## LD

ITEM	QTY.	DESCRIPTION
A	8	3" RECTANGLE TUBING NUT
D	8	1/2" X 1-1/4" HEX HEAD BOLT
H	8	1/2" LOCK WASHER
1	2	SPIDER WELDMENT
2	2	LONG STORAGE WELDMENT
3	4	HDL FOOT
4	4	RUBBER SLIPPER

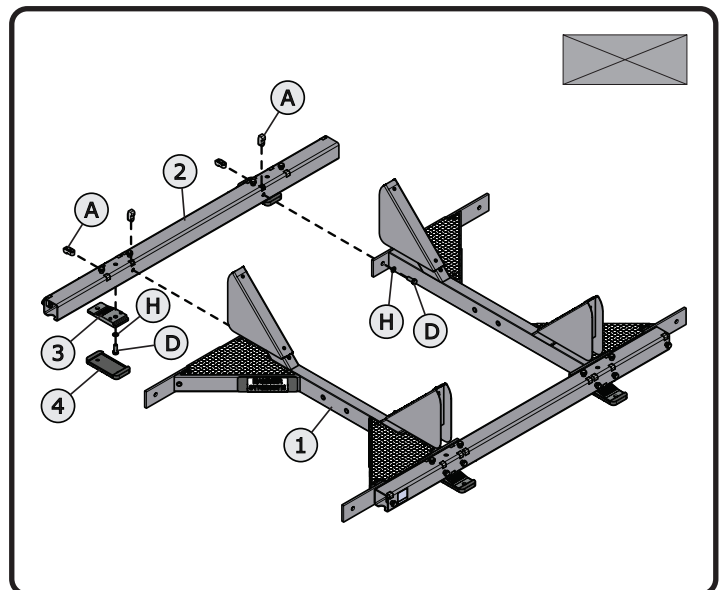

## STORAGE ASSEMBLY

### HR/MR/PR

#### SA

ITEM	QTY.	DESCRIPTION
A	4	3" RECTANGLE TUBING NUT
D	4	1/2" X 1-1/4" HEX HEAD BOLT
F	16	1/2" X 4" HEX HEAD BOLT
G	4	1/2" X 4" HEX HEAD BOLT W/NYLOCK PATCH
H	40	1/2" LOCK WASHER
I	16	1/2" THIN LOCK NUT
1	1	LEFT STORAGE UPRIGHT
2	1	RIGHT STORAGE UPRIGHT
3	8	SHORT WEIGHT HORN
4	2	LONG WEIGHT HORN
5	2	HDL FOOT
6	2	RUBBER SLIPPER

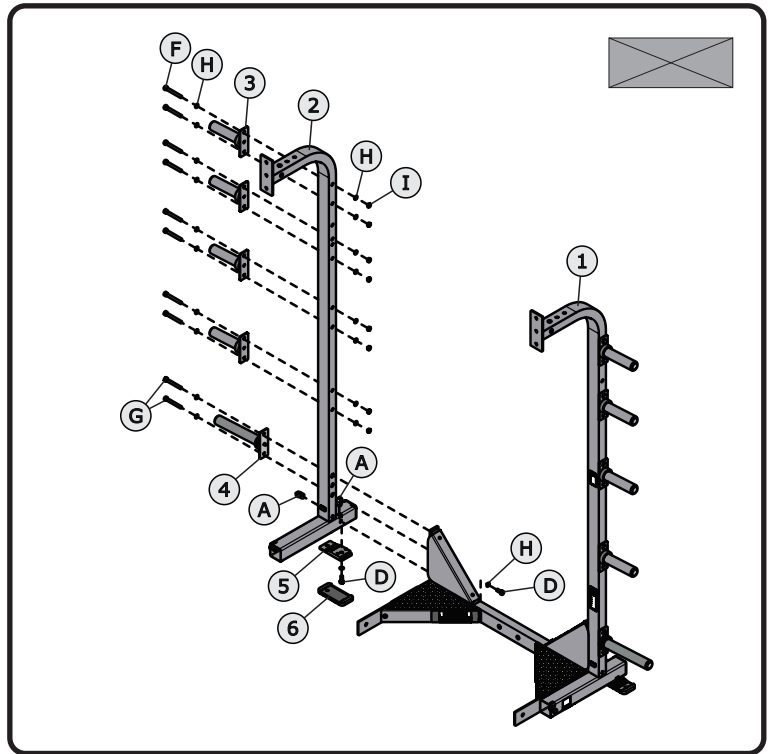

### HR/MR/PR

#### KB/BP

ITEM	QTY.	DESCRIPTION
A	6	3" RECTANGLE TUBING NUT
D	8	1/2" X 1-1/4" HEX HEAD BOLT
F	22	1/2" X 4" HEX HEAD BOLT
G	4	1/2" X 4" HEX HEAD BOLT W/NYLOCK PATCH
H	56	1/2" LOCK WASHER
I	22	1/2" THIN LOCK NUT
1	1	LEFT STORAGE UPRIGHT
2	1	RIGHT STORAGE UPRIGHT
3	8	SHORT WEIGHT HORN
4	2	LONG WEIGHT HORN
5	2	KETTLE BELL TRAY
6	2	HDL FOOT
7	2	RUBBER SLIPPER

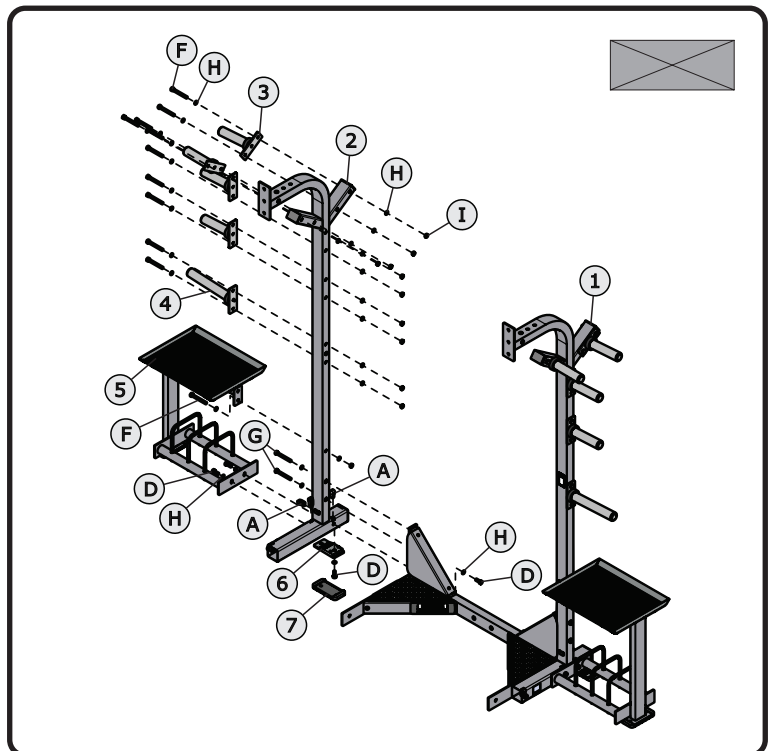

**COMBO**  
KB/BP FRONT LOAD

ITEM	QTY.	DESCRIPTION
A	10	3" RECTANGLE TUBING NUT
D	10	1/2" X 1-1/4" HEX HEAD BOLT
F	26	1/2" X 4" HEX HEAD BOLT
G	4	1/2" X 4" HEX HEAD BOLT W/NYLOCK PATCH
H	58	1/2" LOCK WASHER
I	26	1/2" THIN LOCK NUT
1	2	STORAGE UPRIGHT
2	8	SHORT WEIGHT HORN
3	2	LONG WEIGHT HORN
4	2	KETTLE BELL TRAY/BP (FRONT LOAD)
5	2	HDL FOOT
6	4	RUBBER SLIPPER

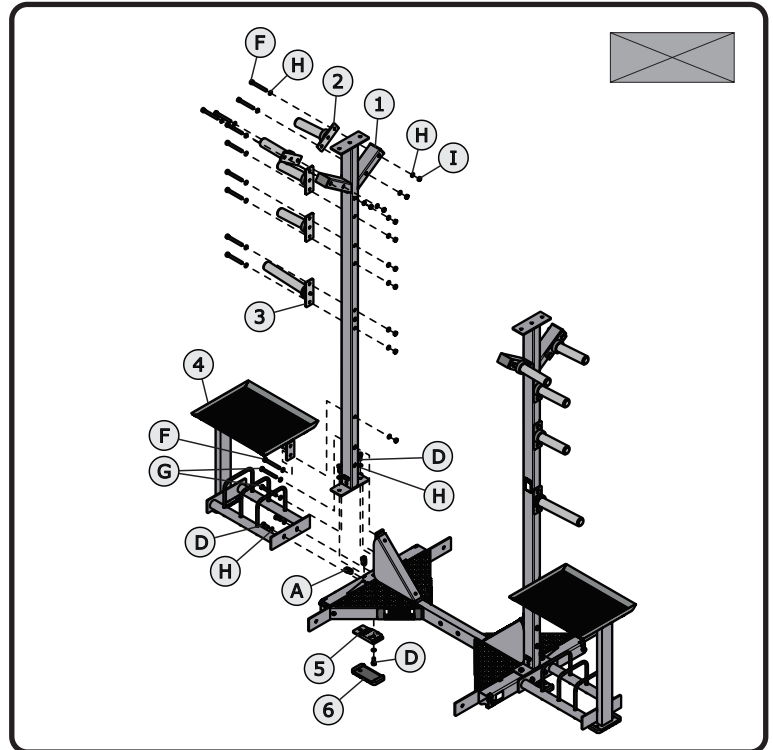

**COMBO**  
KB/BP SIDE LOAD

ITEM	QTY.	DESCRIPTION
A	10	3" RECTANGLE TUBING NUT
D	10	1/2" X 1-1/4" HEX HEAD BOLT
F	26	1/2" X 4" HEX HEAD BOLT
G	4	1/2" X 4" HEX HEAD BOLT W/NYLOCK PATCH
H	58	1/2" LOCK WASHER
I	26	1/2" THIN LOCK NUT
1	2	STORAGE UPRIGHT
2	8	SHORT WEIGHT HORN
3	2	LONG WEIGHT HORN
4	2	KETTLE BELL TRAY/BP (SIDE LOAD)
5	2	BUMPER PLATE RACK (SIDE LOAD)
6	2	HDL FOOT
7	6	RUBBER SLIPPER

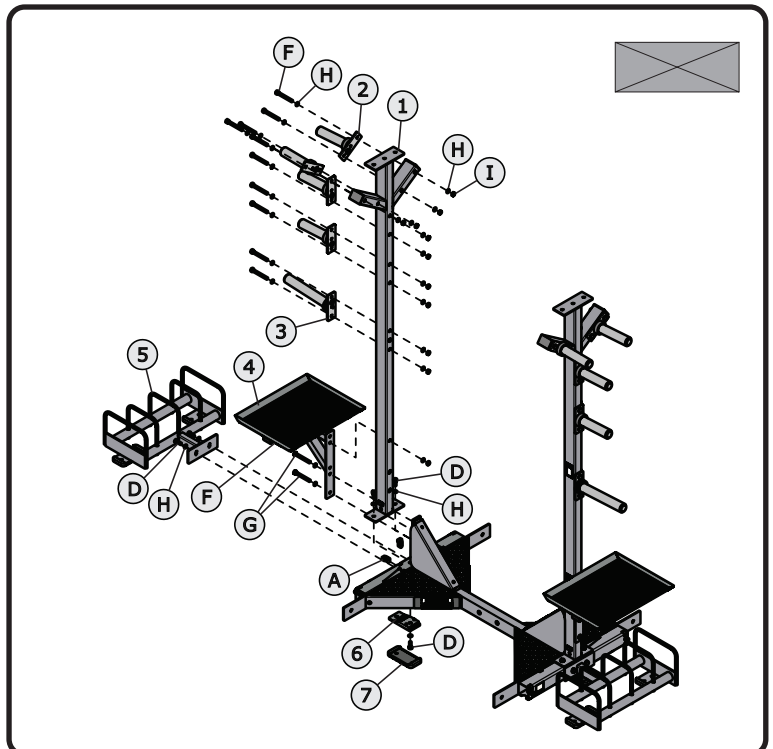

**COMBO**  
**90 DEGREE**

ITEM	QTY.	DESCRIPTION
A	10	3" RECTANGLE TUBING NUT
D	10	1/2" X 1-1/4" HEX HEAD BOLT
F	24	1/2" X 4" HEX HEAD BOLT
G	4	1/2" X 4" HEX HEAD BOLT W/NYLOCK PATCH
H	54	1/2" LOCK WASHER
I	24	1/2" THIN LOCK NUT
1	2	STORAGE UPRIGHT
2	20	SHORT WEIGHT HORN
3	8	LONG WEIGHT HORN
4	2	HDL FOOT
5	4	RUBBER SLIPPER

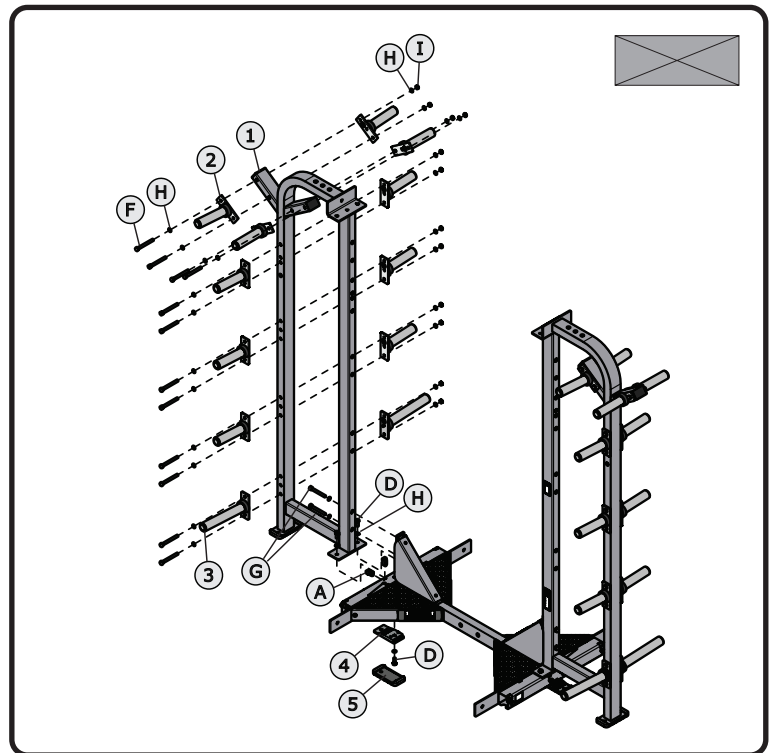

## BASE ASSEMBLY

HR

ITEM	QTY.	DESCRIPTION
A	4	3" RECTANGLE TUBING NUT
D	4	1/2" X 1-1/4" HEX HEAD BOLT
H	4	1/2" LOCK WASHER
1	1	LEFT BASE WELDMENT
2	1	RIGHT BASE WELDMENT
3	4	HDL FOOT
4	4	RUBBER SLIPPER

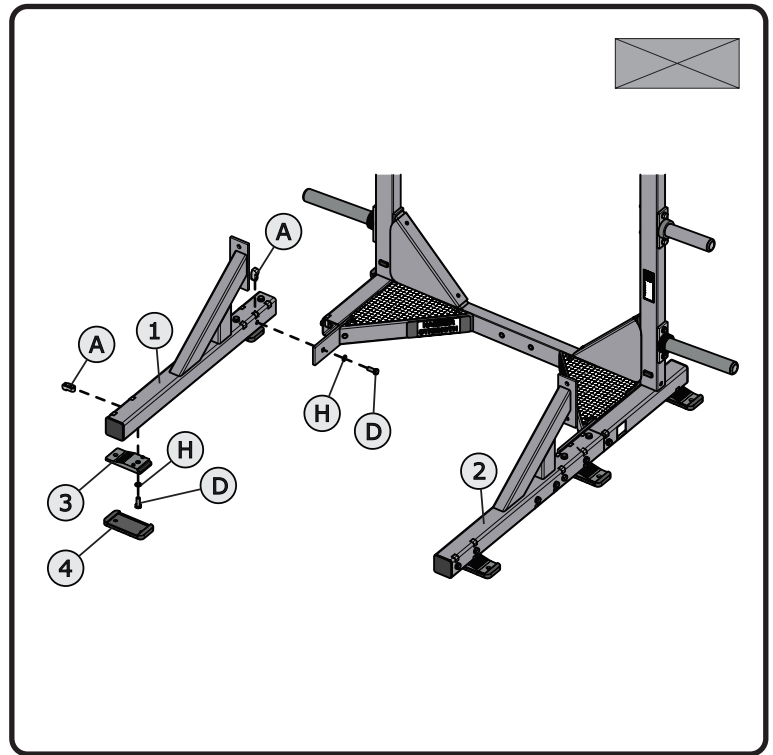

MR/PR

ITEM	QTY.	DESCRIPTION
A	4	3" RECTANGLE TUBING NUT
D	4	1/2" X 1-1/4" HEX HEAD BOLT
H	4	1/2" LOCK WASHER
1	1	LEFT BASE ASSY.
2	1	RIGHT BASE WELDMENT
3	4	HDL FOOT
4	4	RUBBER SLIPPER

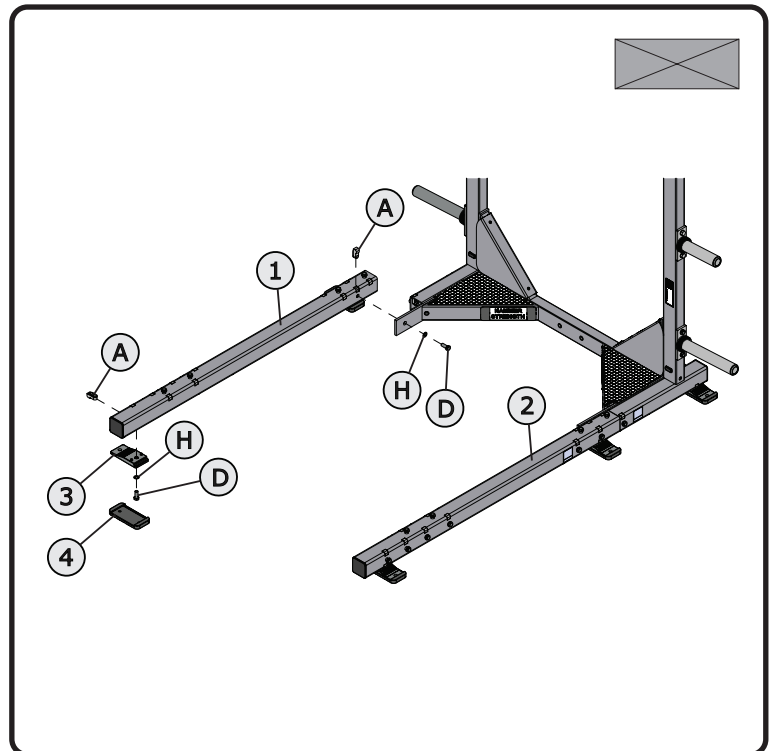

**COMBO**  
**MD**

ITEM	QTY.	DESCRIPTION
A	4	3" RECTANGLE TUBING NUT
D	4	1/2" X 1-1/4" HEX HEAD BOLT
H	4	1/2" LOCK WASHER
1	2	LEFT BASE ASSY.
2	2	RIGHT BASE ASSY.
3	8	HDL FOOT
4	8	RUBBER SLIPPER
5	2	LEFT SUMO BASE ASSY. (OPTIONAL)
6	2	RIGHT SUMO BASE ASSY. (OPTIONAL)

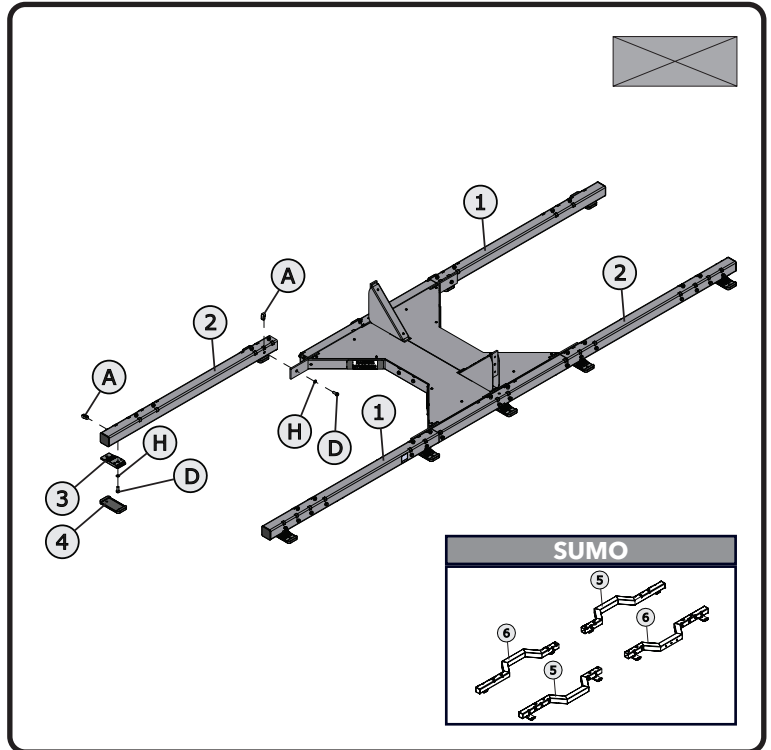

**COMBO**

**HR/DAP, PULLDOWN,  
ROW & CABLE COLUMN**

ITEM	QTY.	DESCRIPTION
A	2	3" RECTANGLE TUBING NUT
D	8	1/2" X 1-1/4" HEX HEAD BOLT
F	2	1/2" X 4" HEX HEAD BOLT
H	10	1/2" LOCK WASHER
I	2	1/2" THIN LOCK NUT
1	1	LEFT TOWER
2	2	RIGHT TOWER
3	8	LOWER ANVIL PLATE

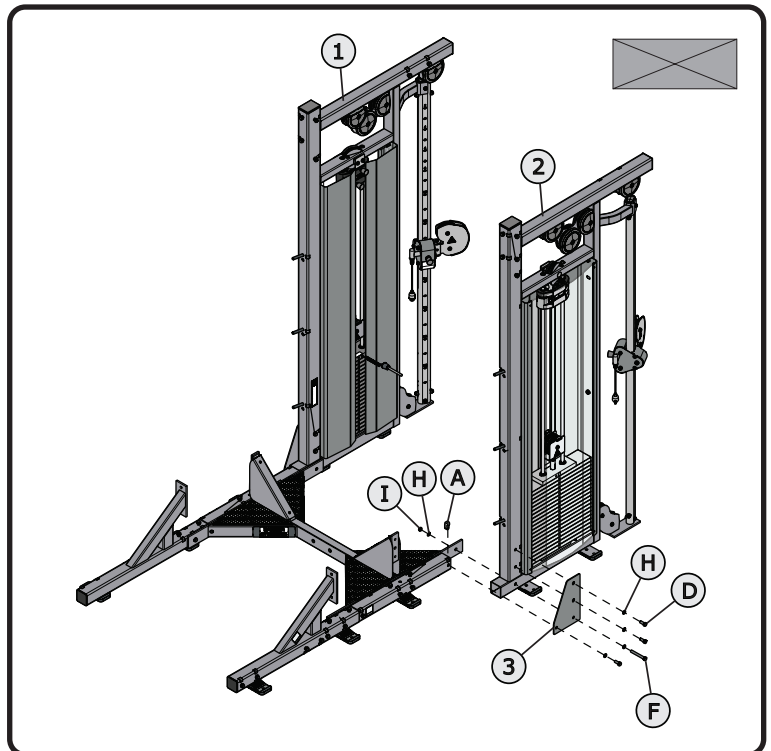

## BENCH ASSEMBLY

### BENCHES

#### PULLDOWN, ROW

ITEM	QTY.	DESCRIPTION
B	2	4" RECTANGLE TUBING NUT
D	2	1/2" X 1-1/4" HEX HEAD BOLT
H	2	1/2" LOCK WASHER
1	1	BENCH ASSY.

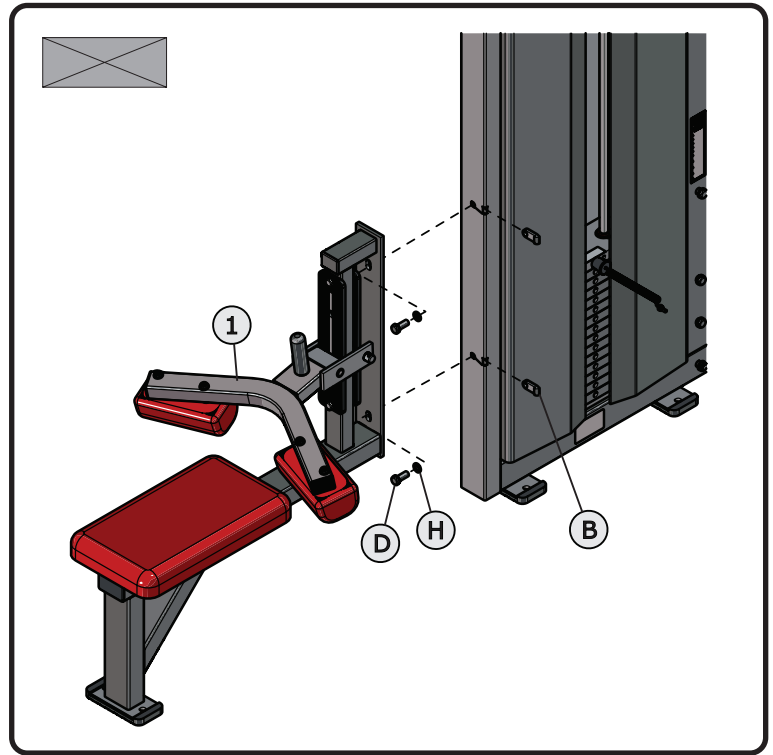

## UPRIGHT ASSEMBLY

### HR

ITEM	QTY.	DESCRIPTION
A	12	3" RECTANGLE TUBING NUT
D	12	1/2" X 1-1/4" HEX HEAD BOLT
H	12	1/2" LOCK WASHER
1	1	LEFT UPRIGHT
2	2	RIGHT UPRIGHT

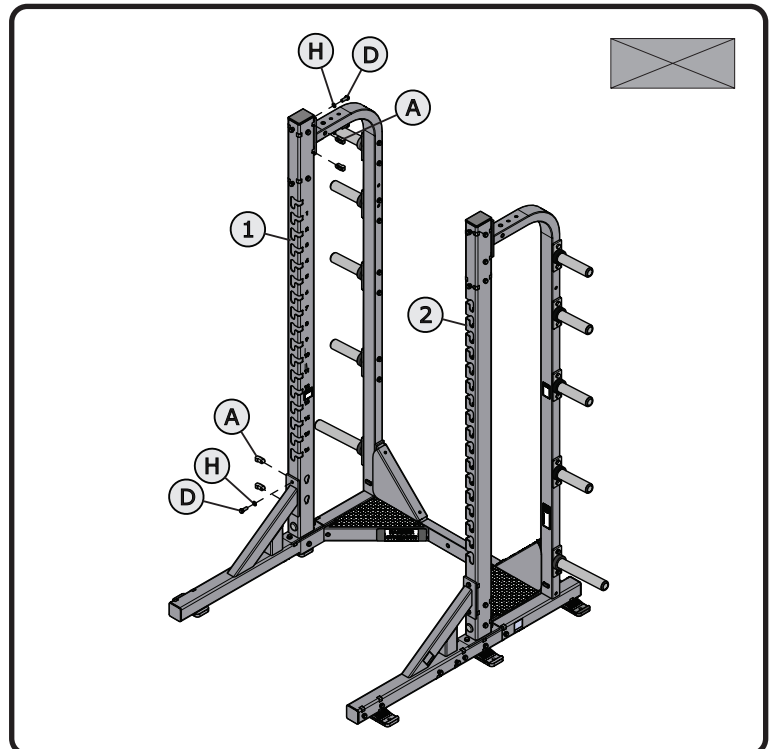

MR

ITEM	QTY.	DESCRIPTION
A	12	3" RECTANGLE TUBING NUT
D	12	1/2" X 1-1/4" HEX HEAD BOLT
H	12	1/2" LOCK WASHER
1	1	LEFT UPRIGHT
2	1	RIGHT UPRIGHT
3	1	LEFT SHORT UPRIGHT
4	1	RIGHT SHORT UPRIGHT

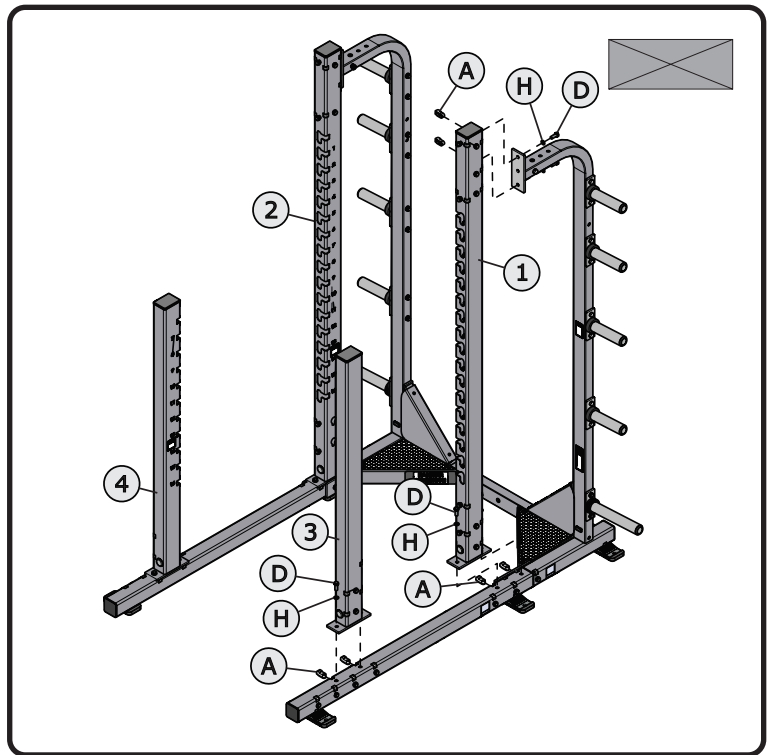

PR

ITEM	QTY.	DESCRIPTION
A	12	3" RECTANGLE TUBING NUT
D	12	1/2" X 1-1/4" HEX HEAD BOLT
H	12	1/2" LOCK WASHER
1	2	LEFT UPRIGHT
2	2	RIGHT UPRIGHT

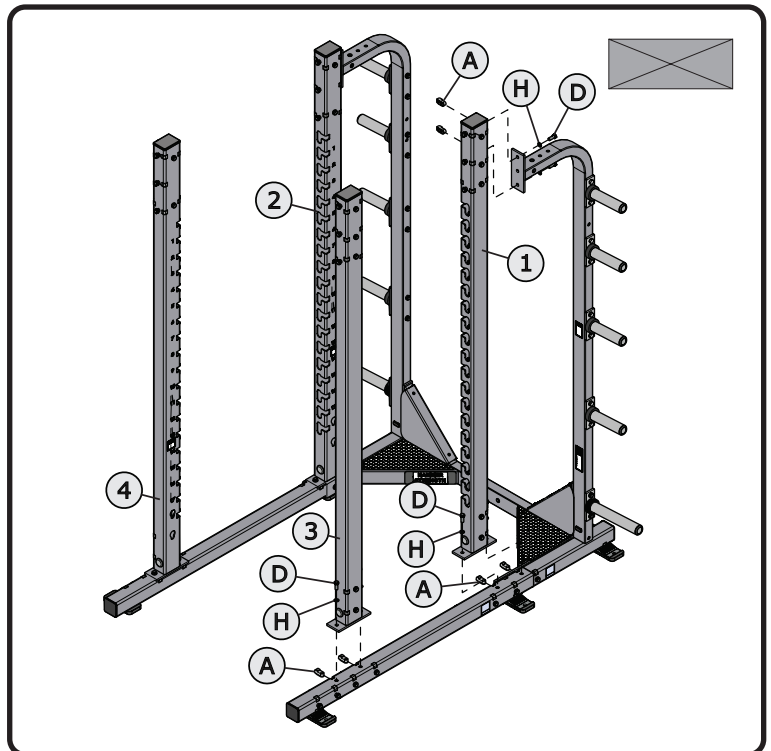

# COMBO

## PR/MR

ITEM	QTY.	DESCRIPTION
A	16	3" RECTANGLE TUBING NUT
D	16	1/2" X 1-1/4" HEX HEAD BOLT
H	16	1/2" LOCK WASHER
1	2	LEFT PR UPRIGHT
2	2	RIGHT PR UPRIGHT
3	1	LEFT MR UPRIGHT
4	1	RIGHT MR UPRIGHT
5	1	SHORT LEFT MR UPRIGHT
6	1	SHORT RIGHT MR UPRIGHT

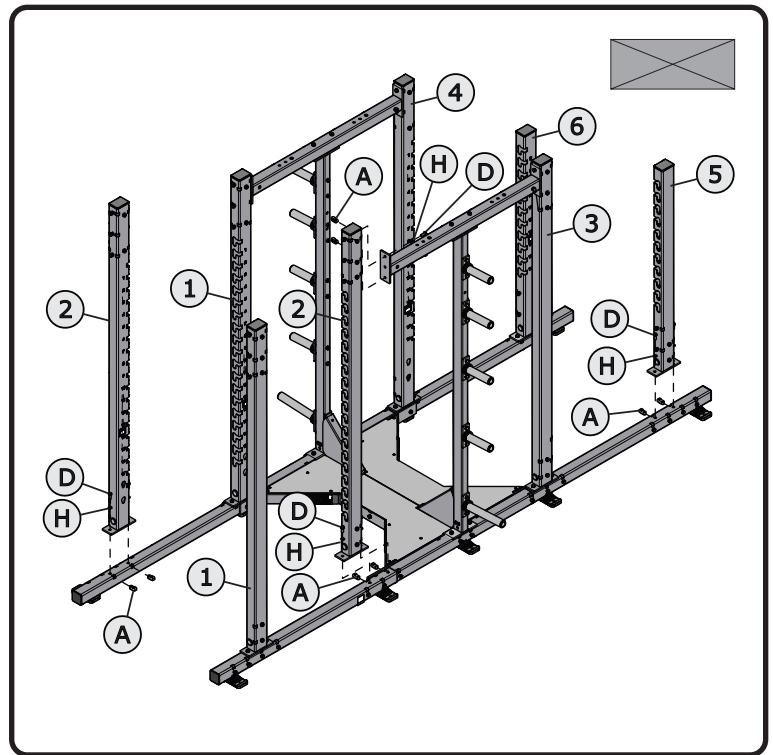

## PULL-UP ASSEMBLY

### HR/MR/COMBO

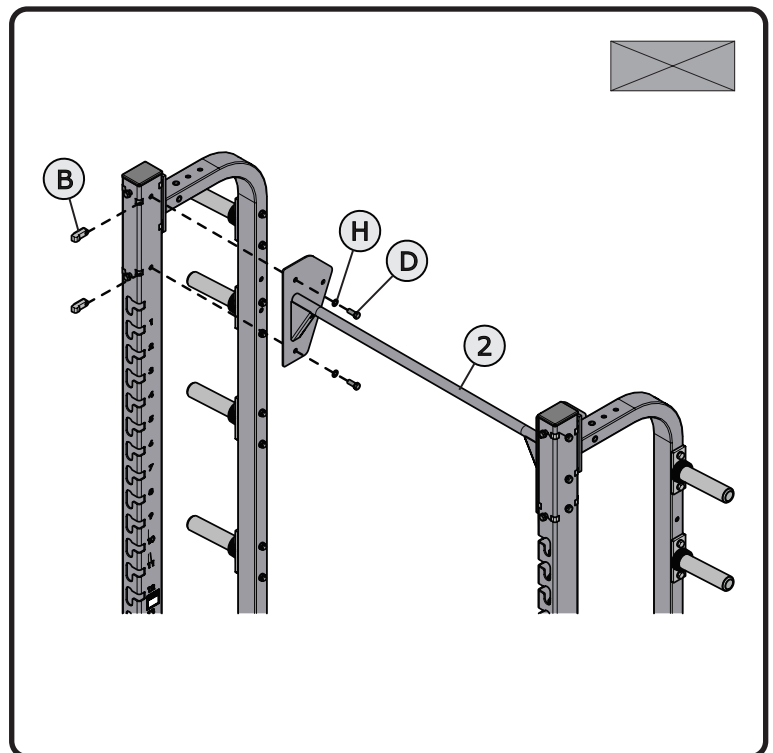
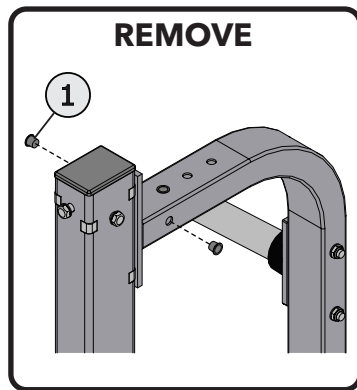

ITEM	QTY.	DESCRIPTION
A	4	3" RECTANGLE TUBING NUT
D	4	1/2" X 1-1/4" HEX HEAD BOLT
H	4	1/2" LOCK WASHER
1	4	HOLE PLUG
2	1	PULL-UP BAR

**3-HANDLE/WING  
PR/COMBO**

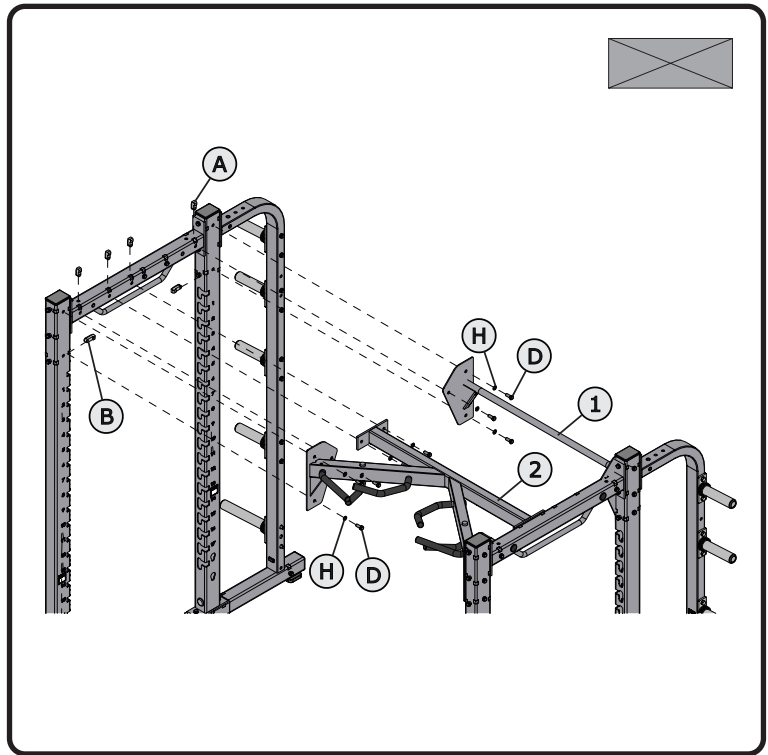
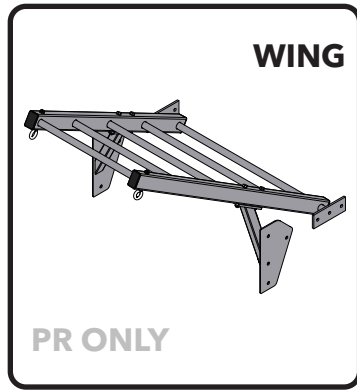

ITEM	QTY.	DESCRIPTION
A	12	3" RECTANGLE TUBING NUT
B	4	4" RECTANGLE TUBING NUT
D	16	1/2" X 1-1/4" HEX HEAD BOLT
H	16	1/2" LOCK WASHER
1	1	PULL-UP BAR
2	1	K PULL-UP BAR

**DAP/CABLE COLUMN/PULLDOWN/ROW**

ITEM	QTY.	DESCRIPTION
A	4	3" RECTANGLE TUBING NUT
D	4	1/2" X 1-1/4" HEX HEAD BOLT
H	4	1/2" LOCK WASHER
1	1	DAP PULL UP

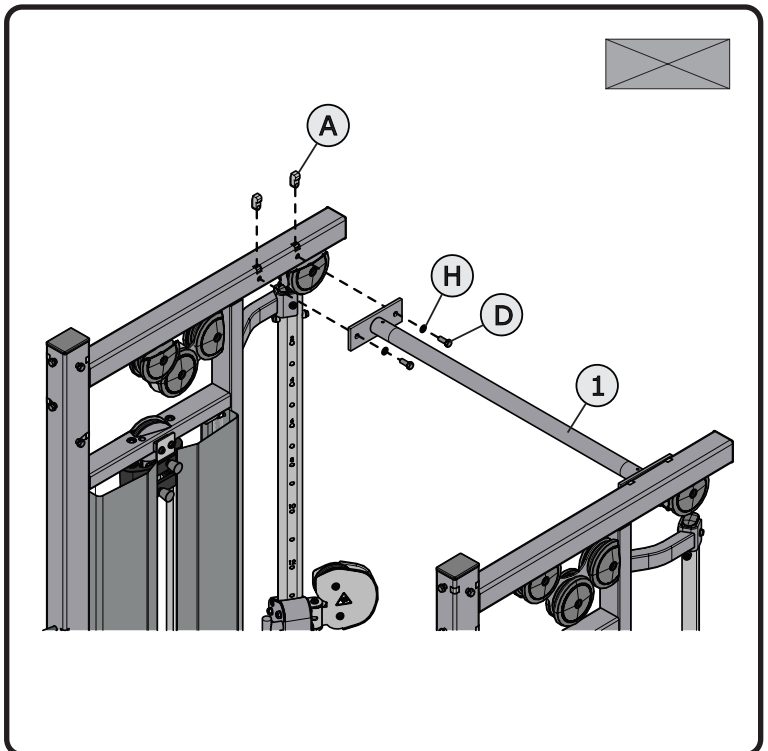

## CROSSMEMBER ASSEMBLY

PR

ITEM	QTY.	DESCRIPTION
A	8	3" RECTANGLE TUBING NUT
D	8	1/2" X 1-1/4" HEX HEAD BOLT
H	8	1/2" LOCK WASHER
1	2	CROSSMEMBERS

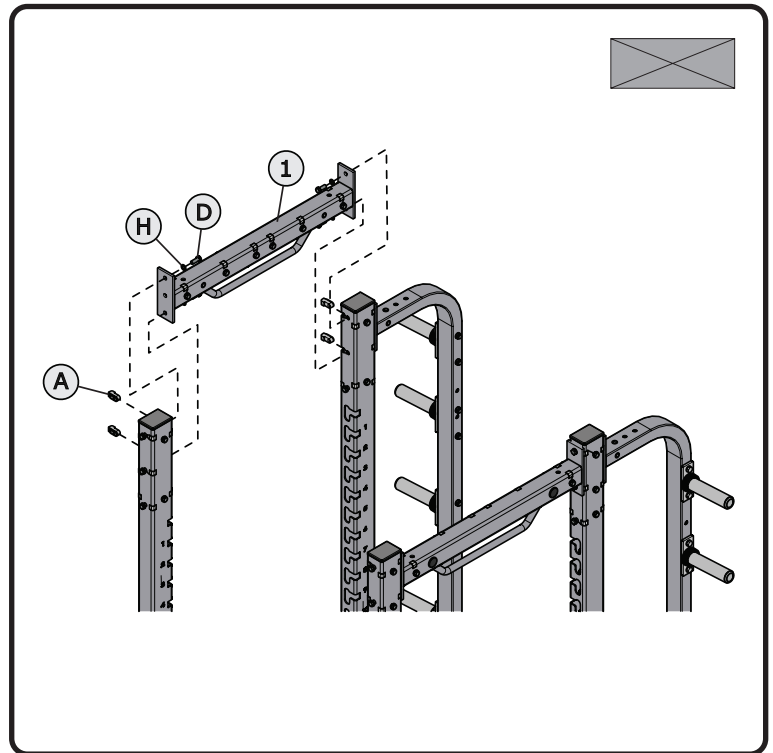

MR

ITEM	QTY.	DESCRIPTION
A	8	3" RECTANGLE TUBING NUT
D	8	1/2" X 1-1/4" HEX HEAD BOLT
H	8	1/2" LOCK WASHER
1	2	CROSSMEMBERS

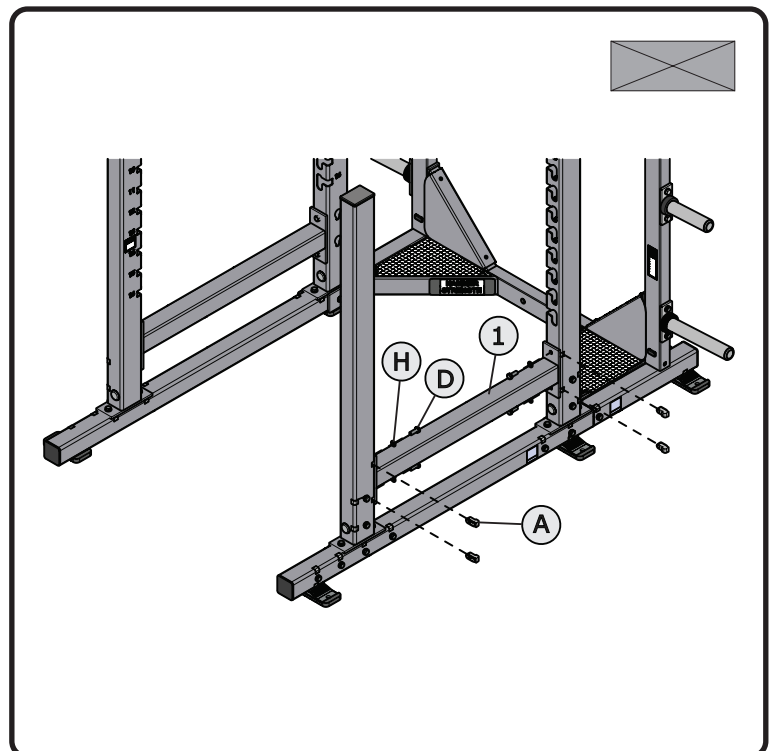

# COMBO

ITEM	QTY.	DESCRIPTION
F	4	1/2" X 4" HEX HEAD BOLT
H	8	1/2" LOCK WASHER
I	4	1/2" THIN LOCK NUT
1	2	CROSSMEMBERS

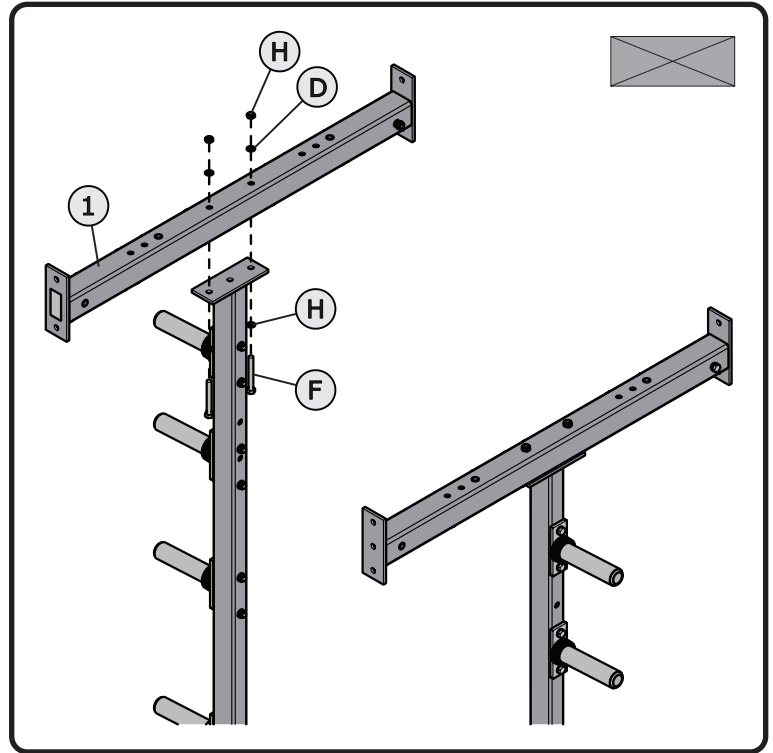

# RACK CONNECTOR ASSEMBLY

- IF EQUIPPED -

- HDLRC-TS

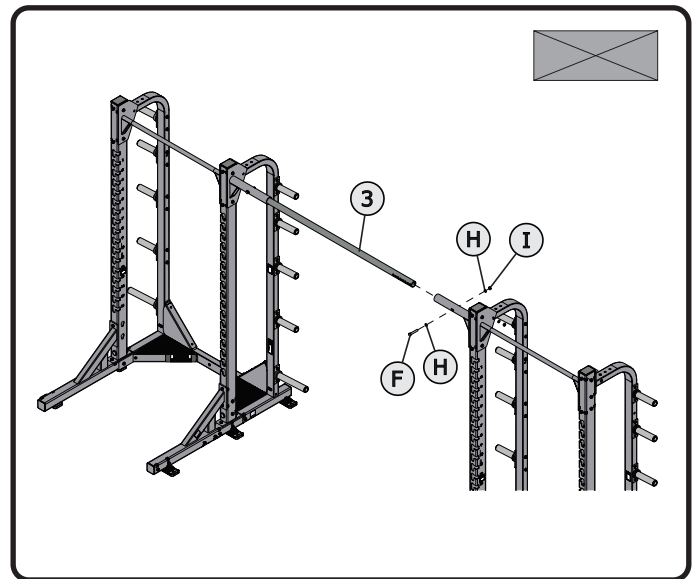
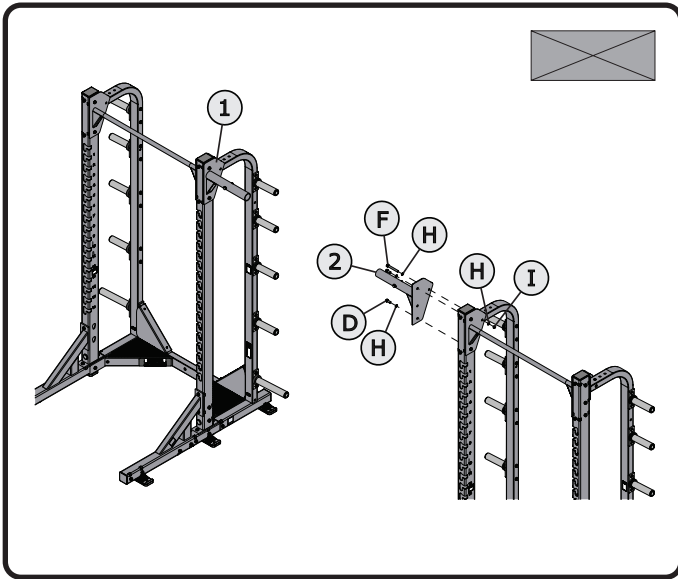

ITEM	QTY.	DESCRIPTION	ITEM	QTY.	DESCRIPTION
D	4	1/2" X 1-1/4" HEX HEAD BOLT	1	1	LEFT CONNECTOR
F	2	1/2" X 4" HEX HEAD BOLT	2	1	RIGHT CONNECTOR
H	8	1/2" LOCK WASHER	3	1	CONNECTOR TUBE
I	2	1/2" THIN LOCK NUT			

- HDLRC-SQ

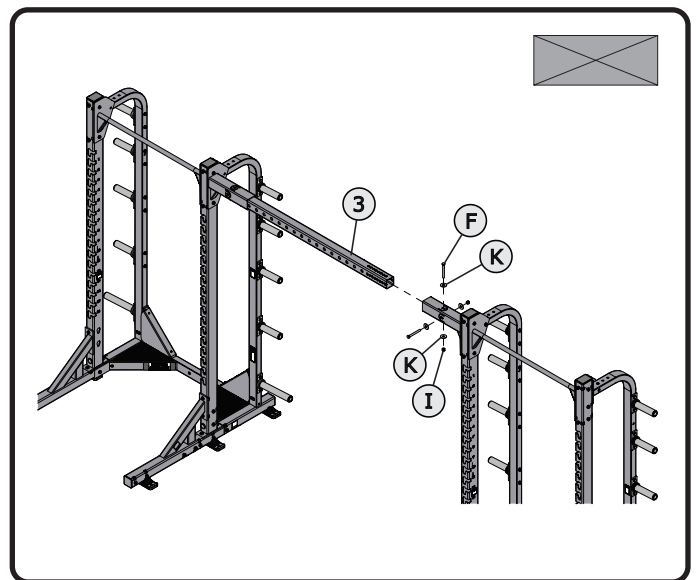
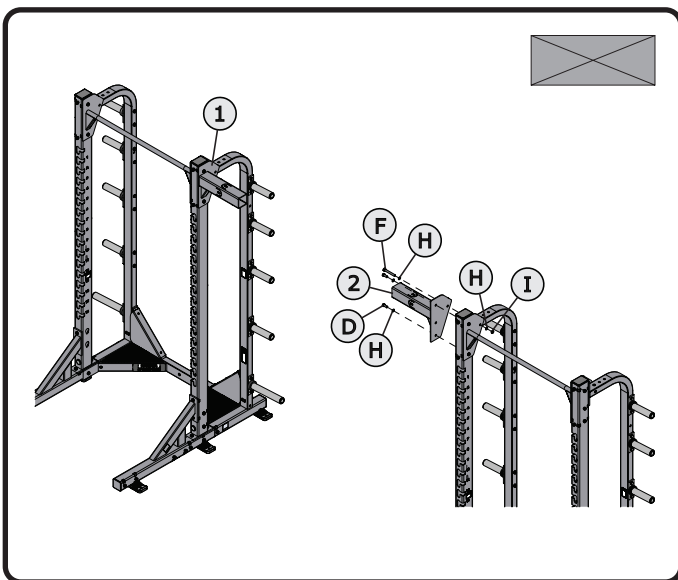

ITEM	QTY.	DESCRIPTION	ITEM	QTY.	DESCRIPTION
D	4	1/2" X 1-1/4" HEX HEAD BOLT	K	8	FENDER WASHER
F	6	1/2" X 4" HEX HEAD BOLT	1	1	LEFT CONNECTOR
H	8	1/2" LOCK WASHER	2	1	RIGHT CONNECTOR
I	6	1/2" THIN LOCK NUT	3	1	CONNECTOR TUBE

# PLATE ASSEMBLY

HR

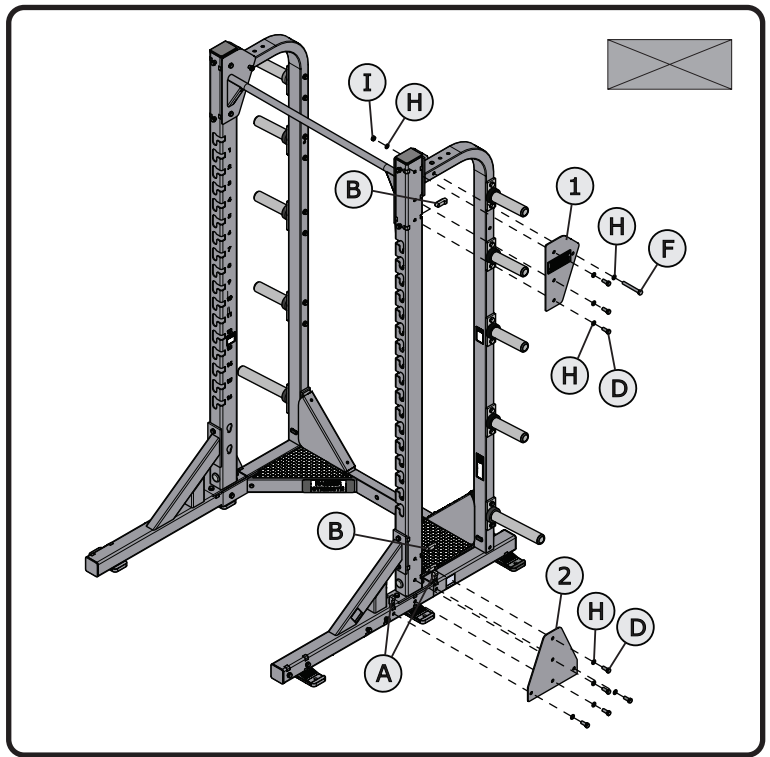
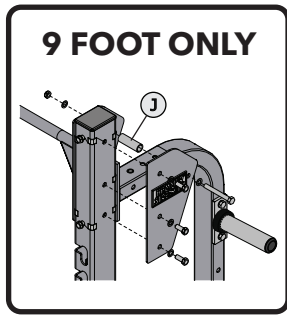

ITEM	QTY.	DESCRIPTION
A	6	3" RECTANGLE TUBING NUT
B	10	4" RECTANGLE TUBING NUT
D	16	1/2" X 1-1/4" HEX HEAD BOLT
F	2	1/2" X 4" HEX HEAD BOLT
H	20	1/2" LOCK WASHER
I	2	1/2" THIN LOCK NUT
J	2	SPACER (9' FOOT ONLY)
1	2	TOP ANVIL PLATE
2	2	BOTTOM ANVIL PLATE

MR

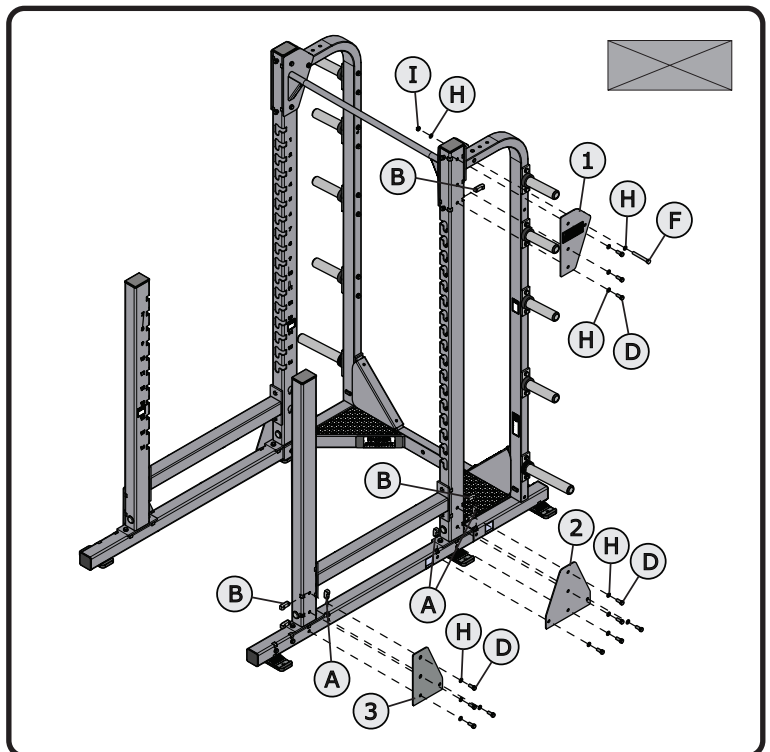
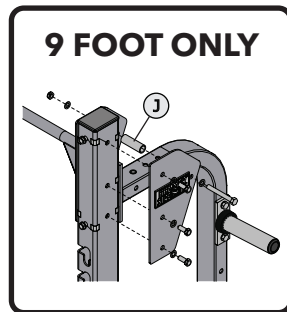

ITEM	QTY.	DESCRIPTION
A	10	3" RECTANGLE TUBING NUT
B	14	4" RECTANGLE TUBING NUT
D	24	1/2" X 1-1/4" HEX HEAD BOLT
F	2	1/2" X 4" HEX HEAD BOLT
H	28	1/2" LOCK WASHER
I	2	1/2" THIN LOCK NUT
J	2	SPACER (9' FOOT ONLY)
1	2	TOP ANVIL PLATE
2	2	BOTTOM ANVIL PLATE
3	2	BACK ANVIL PLATE

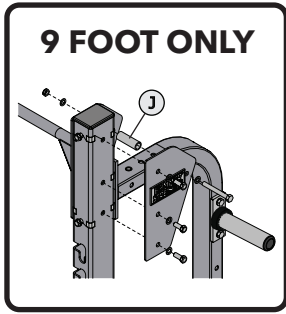

ITEM	QTY.	DESCRIPTION
A	14	3" RECTANGLE TUBING NUT
B	20	4" RECTANGLE TUBING NUT
D	34	1/2" X 1-1/4" HEX HEAD BOLT
H	34	1/2" LOCK WASHER
J	2	SPACER (9' FOOT ONLY)
1	4	TOP ANVIL PLATE
2	2	BOTTOM ANVIL PLATE
3	2	BACK ANVIL PLATE

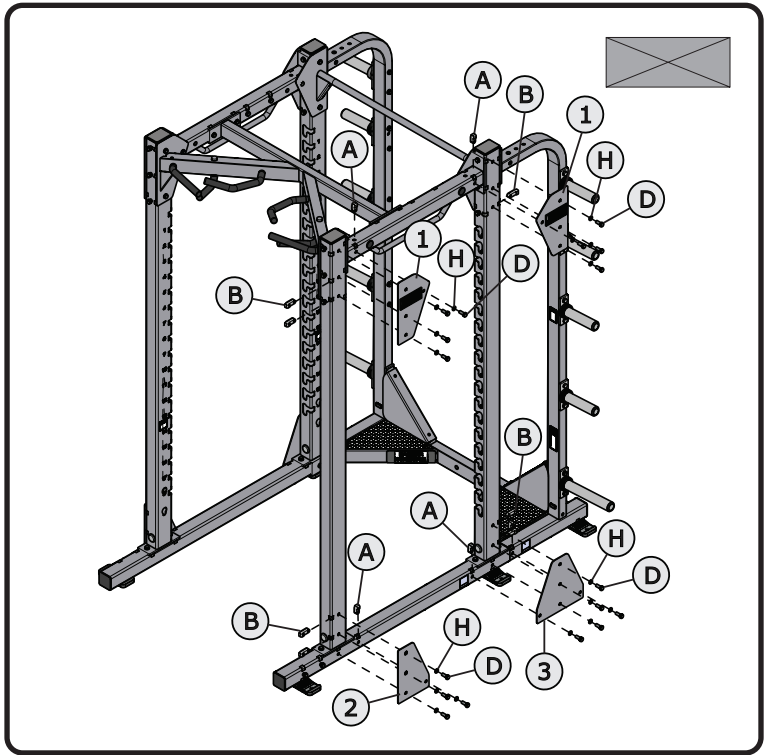

**BAR HANGER ASSEMBLY**  
**- IF EQUIPPED -**

HR/MR/PR

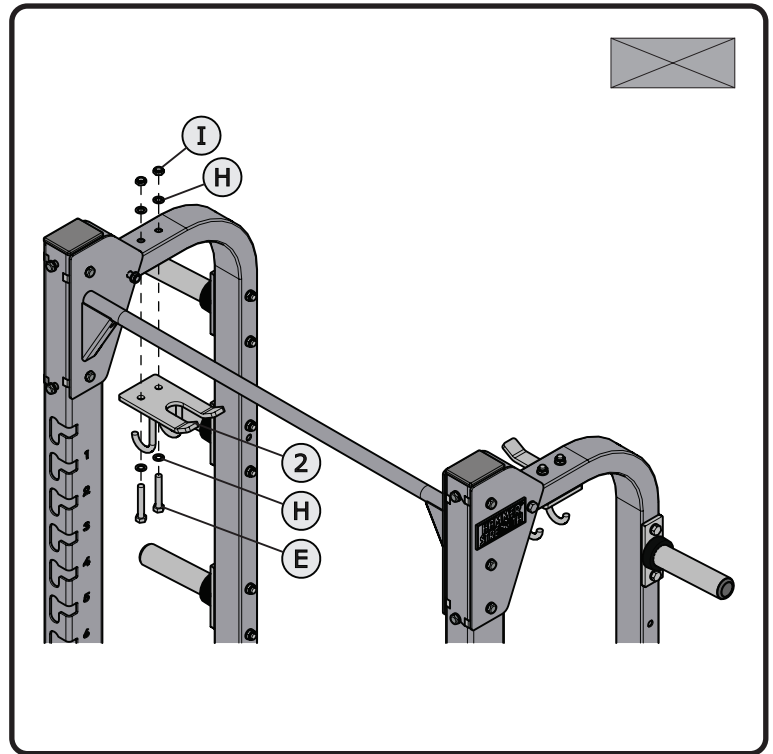
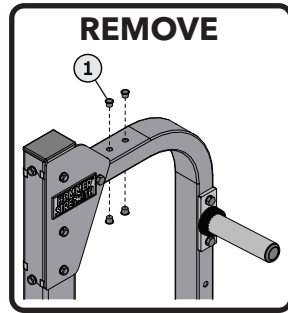

ITEM	QTY.	DESCRIPTION
E	4	1/2" X 3" HEX HEAD BOLT
H	8	1/2" LOCK WASHER
I	4	1/2" THIN LOCK NUT
1	8	HOLE PLUG
2	2	BAR CHAIN (SMALL/LARGE)

**COMBO**

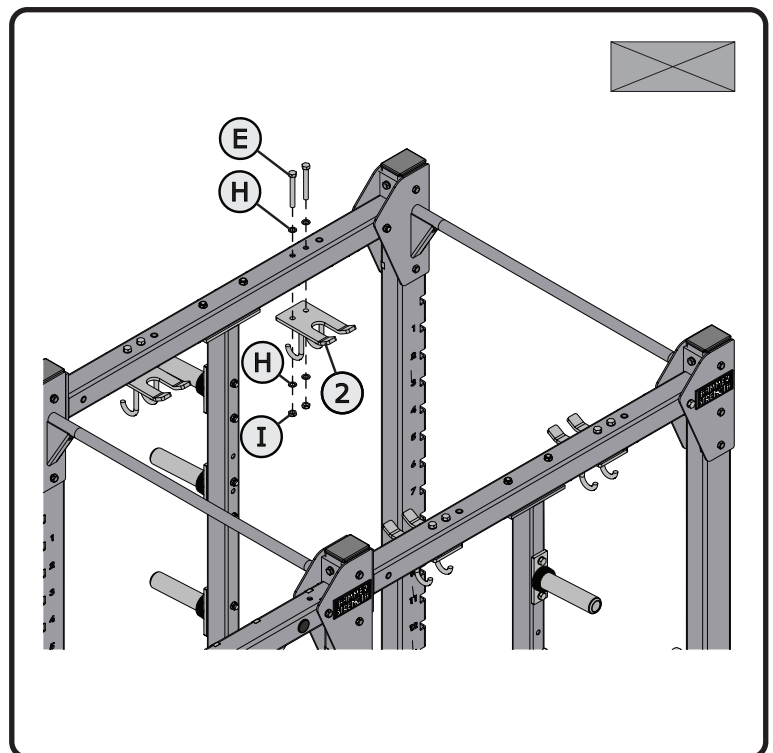
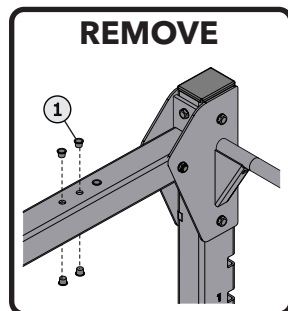

ITEM	QTY.	DESCRIPTION
E	8	1/2" X 3" HEX HEAD BOLT
H	16	1/2" LOCK WASHER
I	8	1/2" THIN LOCK NUT
1	16	HOLE PLUG
2	4	BAR CHAIN (SMALL/LARGE)

# HANG ACCESSORIES

UNIT	ITEM	QTY.	DESCRIPTION
HR	1	2	BAR SUPPORT
	2	2	BAR CATCH - HR
MR	1	2	BAR SUPPORT
	3	2	BAR CATCH - MR/PR
PR	3	2	BAR CATCH - MR/PR
	4	2	REVERSE BAR SUPPORT (L/R)

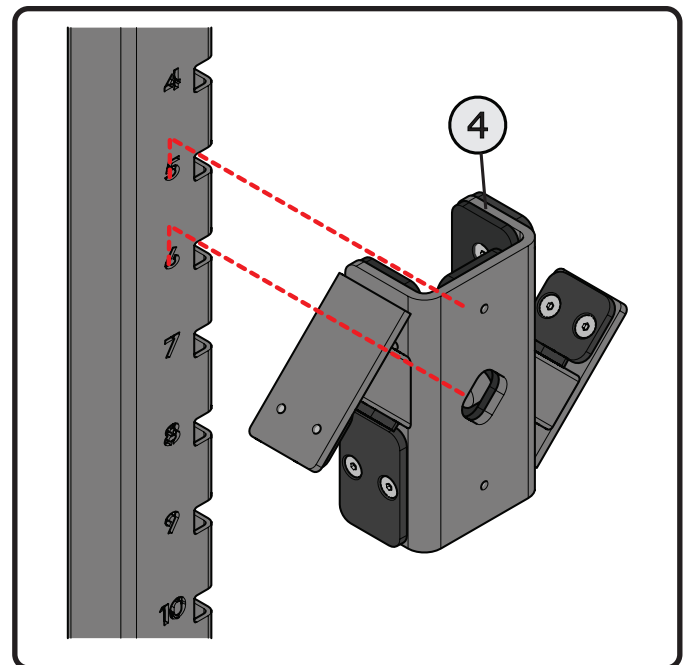
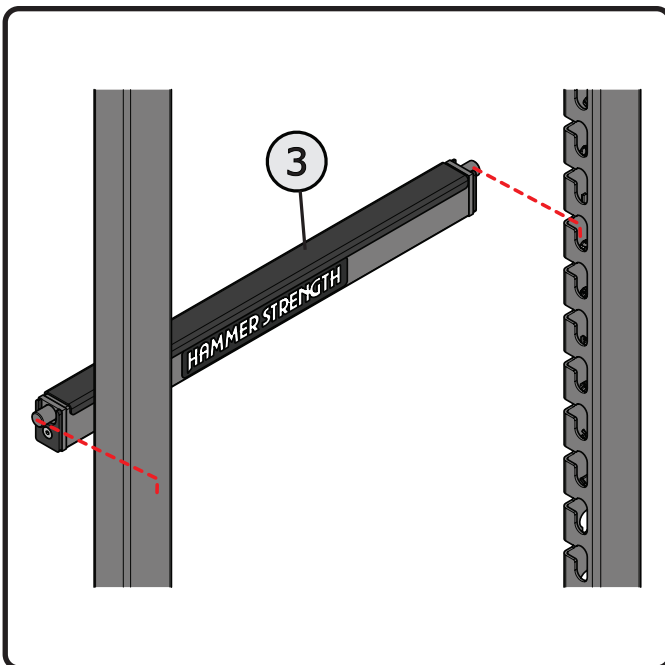
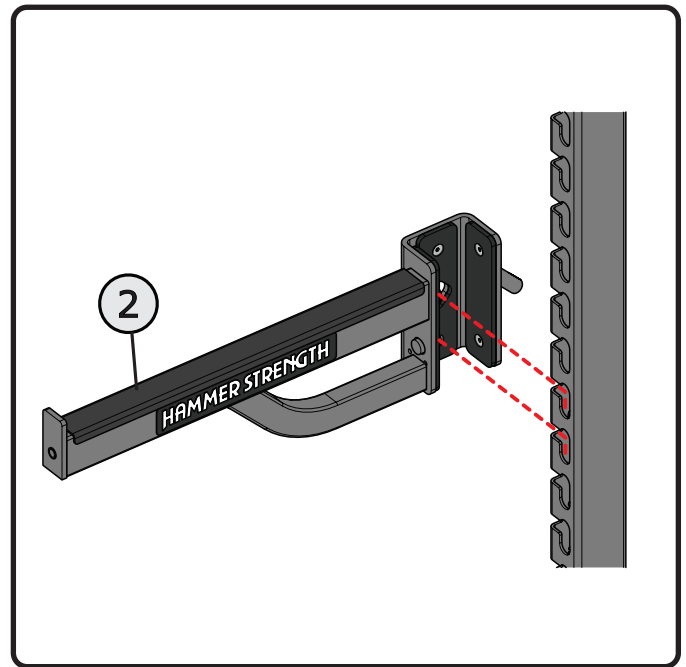
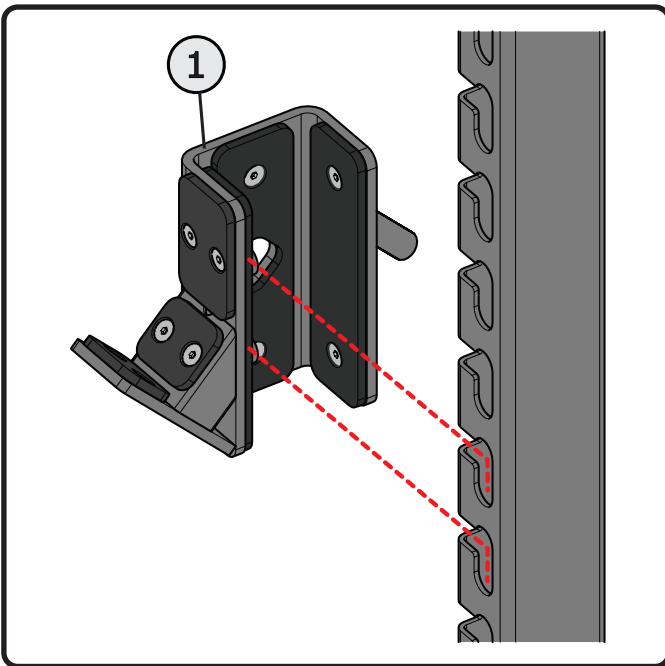

## CABLE STATION INSTRUCTIONS

### ATTACH BASE

- PULL DOWN, ROW AND DAP

ITEM	QTY.	DESCRIPTION
<b>B</b>	2	4" RECTANGLE TUBING NUT
<b>D</b>	2	1/2" X 1-1/4" HEX HEAD BOLT
<b>F</b>	1	1/2" X 4" HEX HEAD BOLT
<b>H</b>	4	1/2" LOCK WASHER
<b>I</b>	1	1/2" THIN LOCK NUT
<b>1</b>	2	CROSSMEMBERS
<b>2</b>	1	3" X 3" END CAP

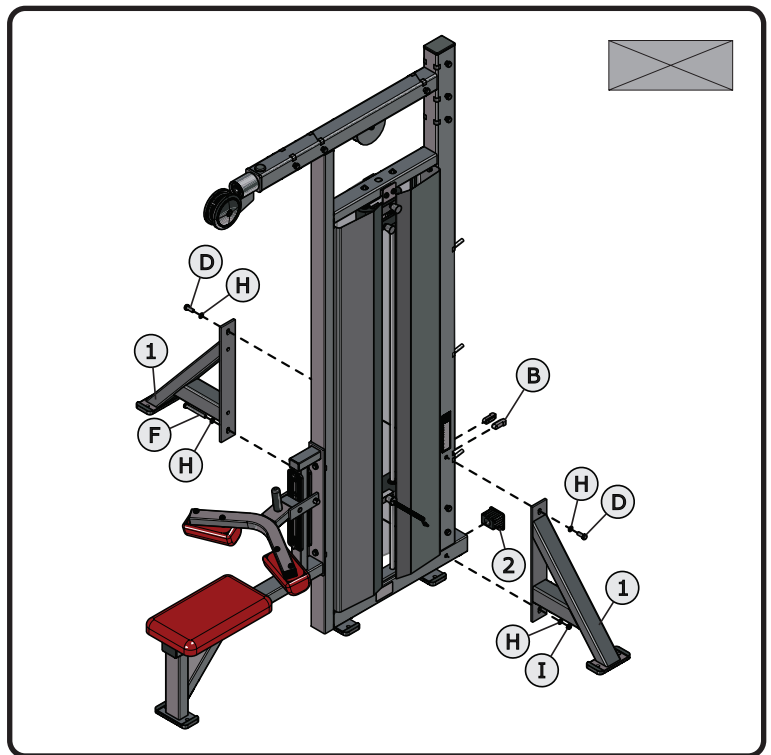

### ATTACH BASE

- DAP

ITEM	QTY.	DESCRIPTION
<b>A</b>	2	3" RECTANGLE TUBING NUT
<b>D</b>	6	1/2" X 1-1/4" HEX HEAD BOLT
<b>F</b>	1	1/2" X 4" HEX HEAD BOLT
<b>H</b>	8	1/2" LOCK WASHER
<b>I</b>	1	1/2" THIN LOCK NUT
<b>1</b>	2	BOTTOM ANVIL PLATE
<b>2</b>	1	BASE WELDMENT

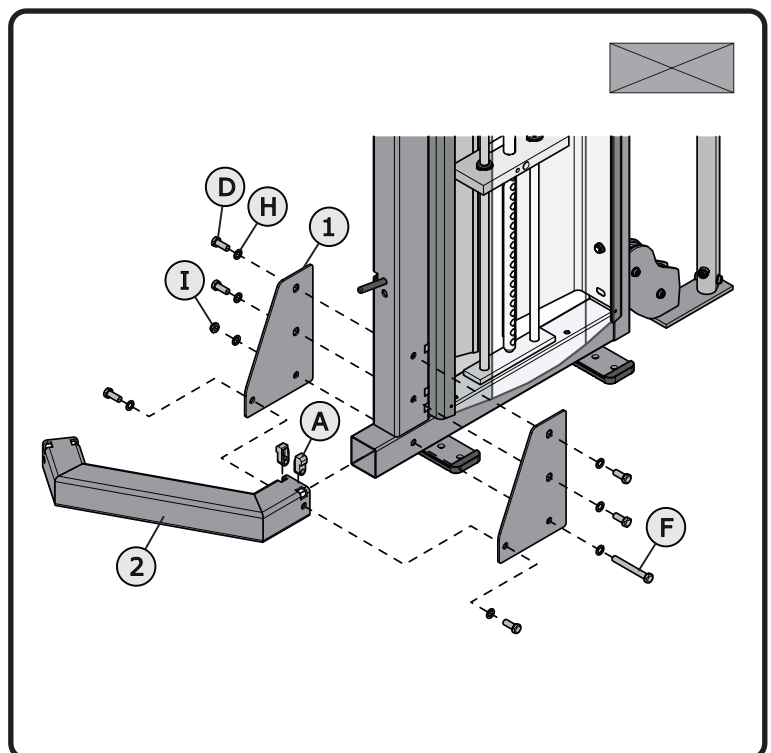

## ATTACH TOP PLATES

- PULL DOWN, ROW AND DAP

ITEM	QTY.	DESCRIPTION
A	2	3" RECTANGLE TUBING NUT
B	6	4" RECTANGLE TUBING NUT
D	8	1/2" X 1-1/4" HEX HEAD BOLT
H	8	1/2" LOCK WASHER
1	2	TOP ANVIL PLATE

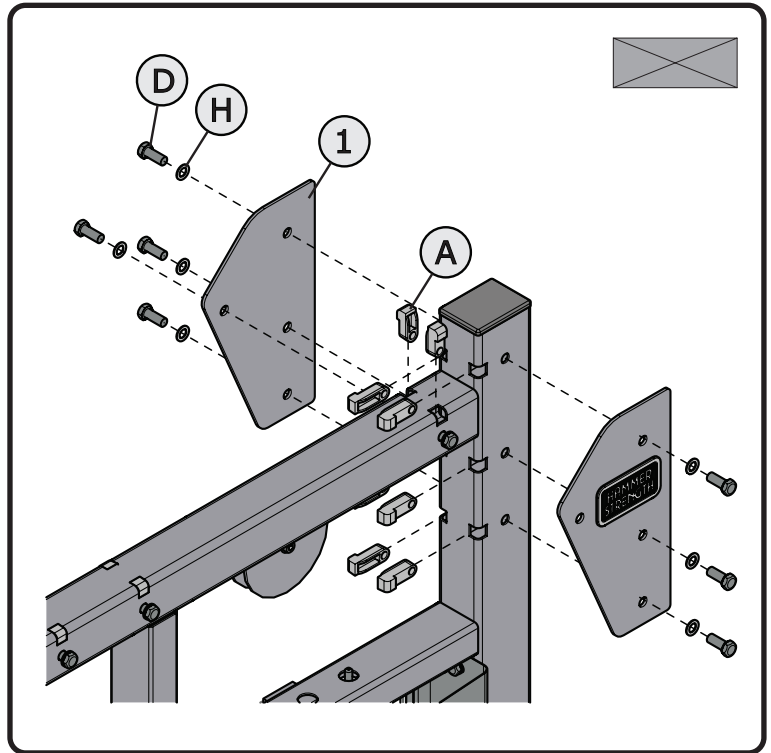

## ATTACH TOP BRACE

- DAP

ITEM	QTY.	DESCRIPTION
A	2	3" RECTANGLE TUBING NUT
B	5	4" RECTANGLE TUBING NUT
D	7	1/2" X 1-1/4" HEX HEAD BOLT
F	1	1/2" X 4" HEX HEAD BOLT
H	9	1/2" LOCK WASHER
I	1	1/2" THIN LOCK NUT
1	2	TOP ANVIL PLATE
2	1	BASE WELDMENT

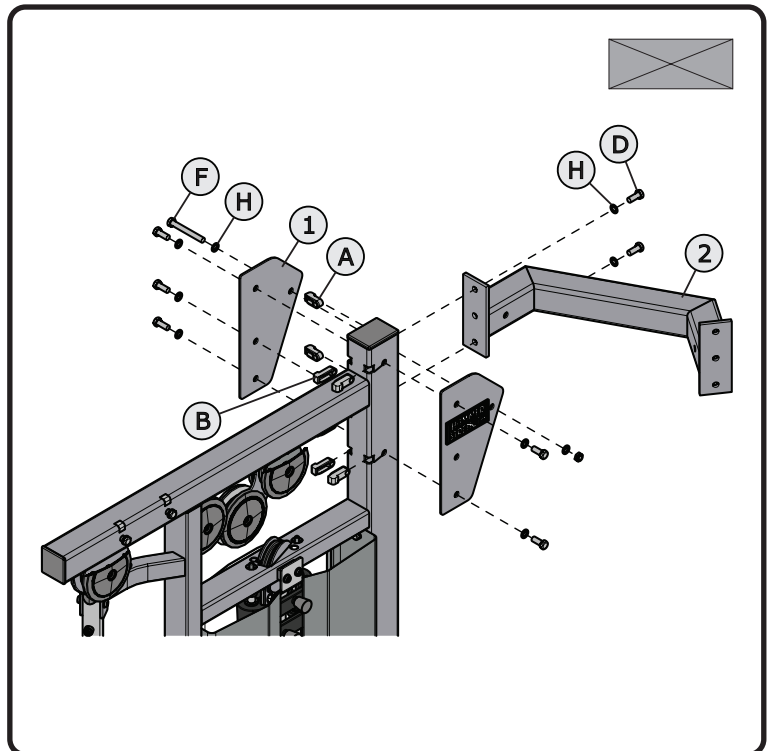

## ATTACH PULL UP

- DAP

ITEM	QTY.	DESCRIPTION
<b>A</b>	4	3" RECTANGLE TUBING NUT
<b>D</b>	4	1/2" X 1-1/4" HEX HEAD BOLT
<b>H</b>	4	1/2" LOCK WASHER
<b>1</b>	1	PULL UP HANDLE

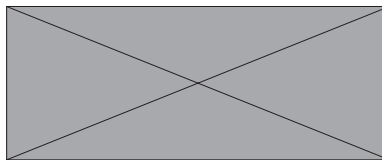
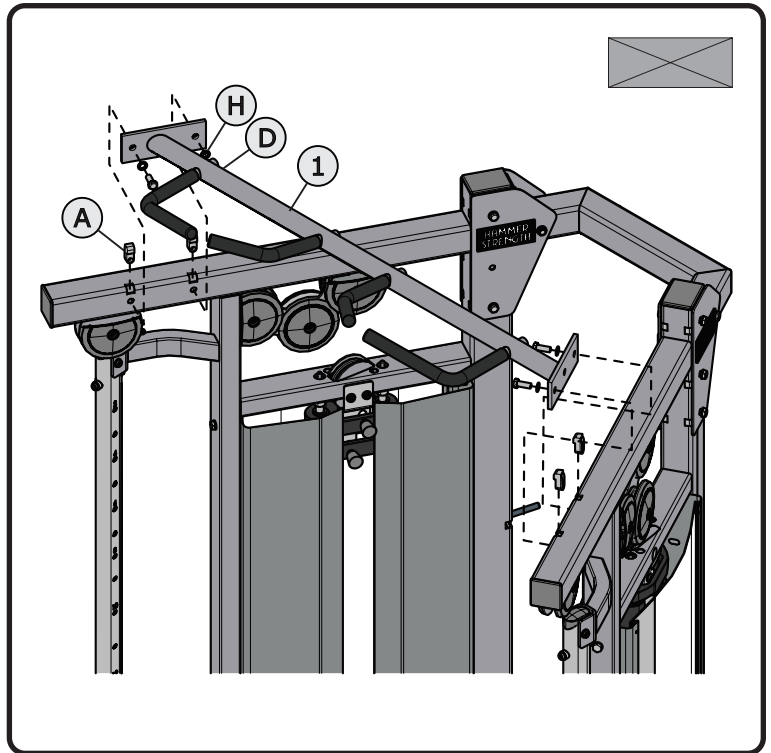

### TIGHTEN ALL HARDWARE

Check to ensure all Hammer Locks are in place and that all hardware is tightened to the below specifications.

ITEM	DESCRIPTION	TORQUE SETTING
<b>C</b>	1/4" X 3/4" BUTTON HEAD SOCKET SCREW	30-39 FT LBS (40.7-52.9 Nm)
<b>D-G</b>	1/2" HEX HEAD BOLT	45-50 FT LBS (61.0-67.8 Nm)
<b>I</b>	1/2" THIN LOCK NUT	45-50 FT LBS (61.0-67.8 Nm)

# CABLE STATION INSTRUCTIONS

## WEIGHT STACK ASSEMBLY

### REMOVE REAR SHROUD

ITEM	QTY.	DESCRIPTION
1	4	RIVET
2	1	REAR SHROUD

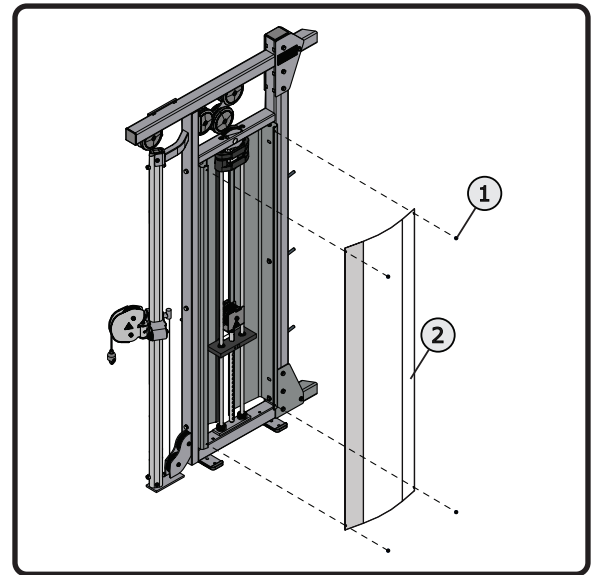

### LOOSEN RETAINER SCREW

ITEM	QTY.	DESCRIPTION
1	2	RETAINER SCREW

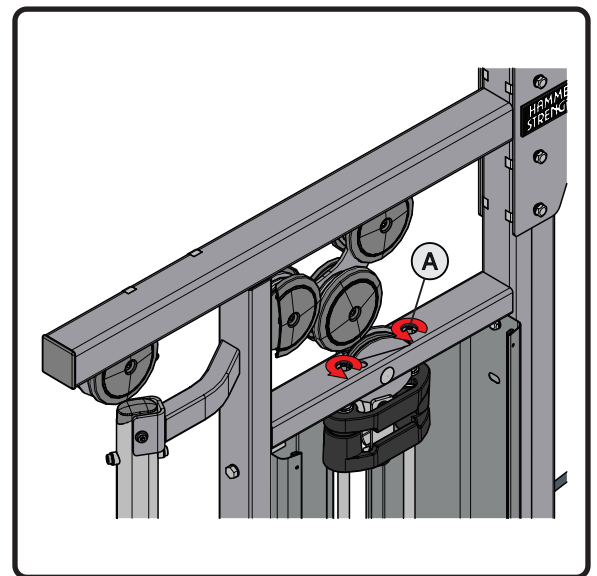

### RELEASE RETAINER RINGS

ITEM	QTY.	DESCRIPTION
1	2	RETAINER RINGS

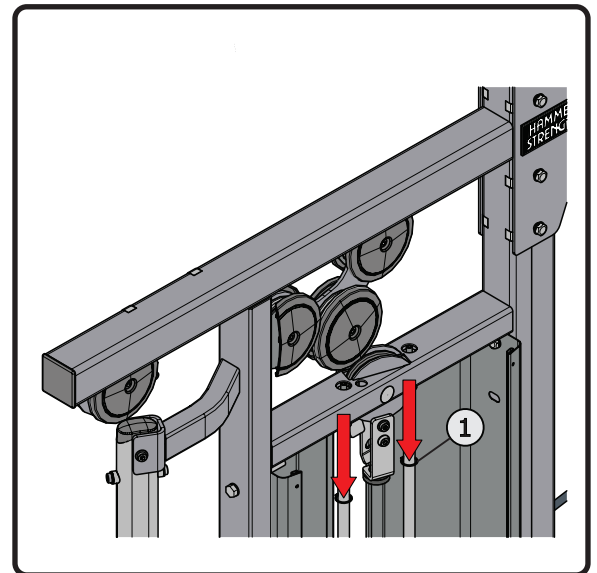

## REMOVE GUIDE ROD RETAINERS

ITEM	QTY.	DESCRIPTION
1	2	GUIDE ROD RETAINERS

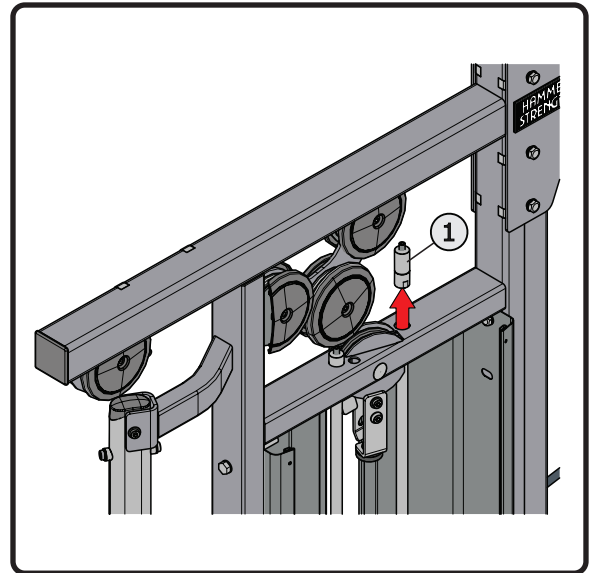

## REMOVE CABLE DRIVE

ITEM	QTY.	DESCRIPTION
1	2	RETAINER RING
2	2	INCREMENTAL WEIGHT
3	1	HEAD PLATE ASSEMBLY
4	2	GUIDE ROD
5	2	GUIDE ROD CUSHION

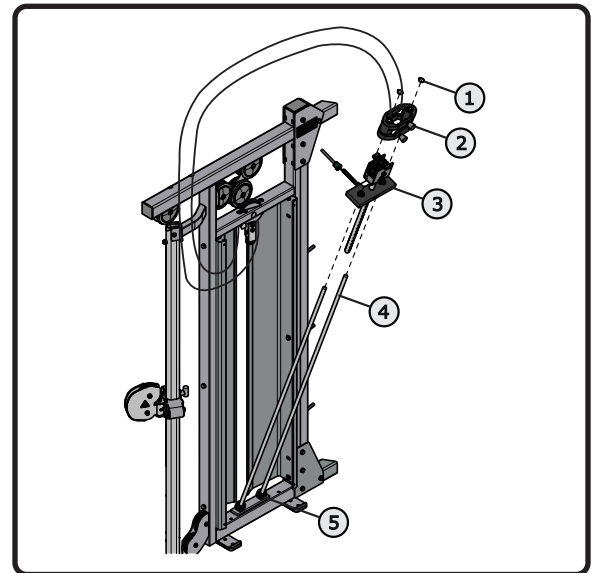

## SWITCH GUIDE RODS

ITEM	QTY.	DESCRIPTION
1	2	TEMPORARY GUIDE RODS

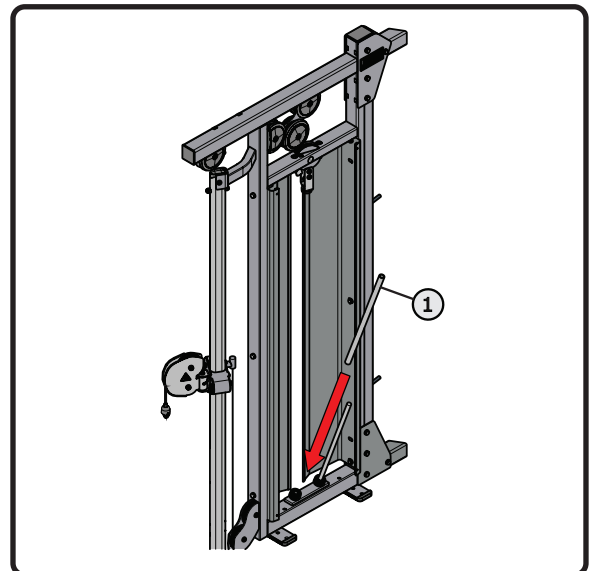

## ADD WEIGHT PLATES

ITEM	UNIT	QTY.	DESCRIPTION
1	CC/DAP	19	20LB WEIGHT PLATE
	PD/ROW	14	

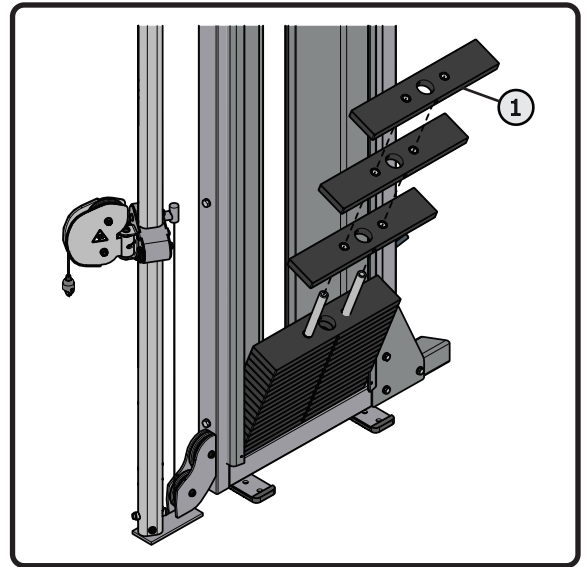

## SWITCH GUIDE RODS

ITEM	QTY.	DESCRIPTION
1	2	TEMPORARY GUIDE ROD
2	2	GUIDE ROD

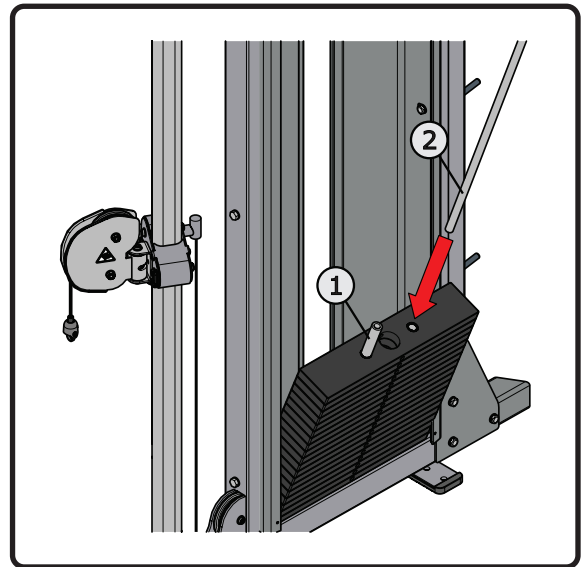

## REPLACE CABLE DRIVE

ITEM	QTY.	DESCRIPTION
1	2	RETAINER RING
2	2	INCREMENTAL WEIGHT
3	1	HEAD PLATE ASSEMBLY
4	2	GUIDE ROD
5	2	GUIDE ROD CUSHION

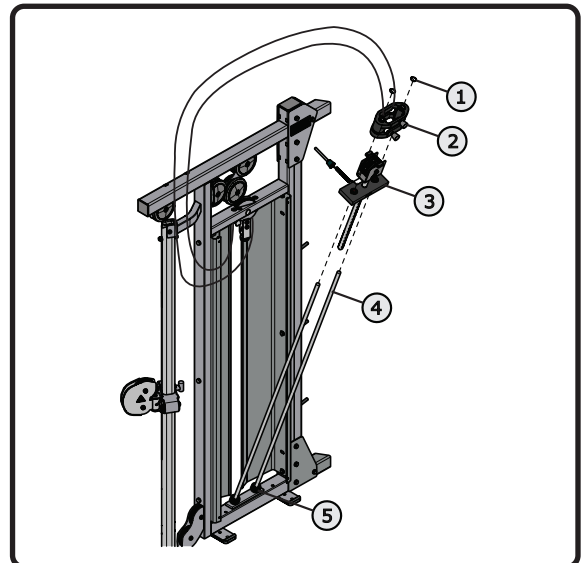

## REPLACE GUIDE ROD RETAINERS

ITEM	QTY.	DESCRIPTION
1	2	GUIDE ROD RETAINERS

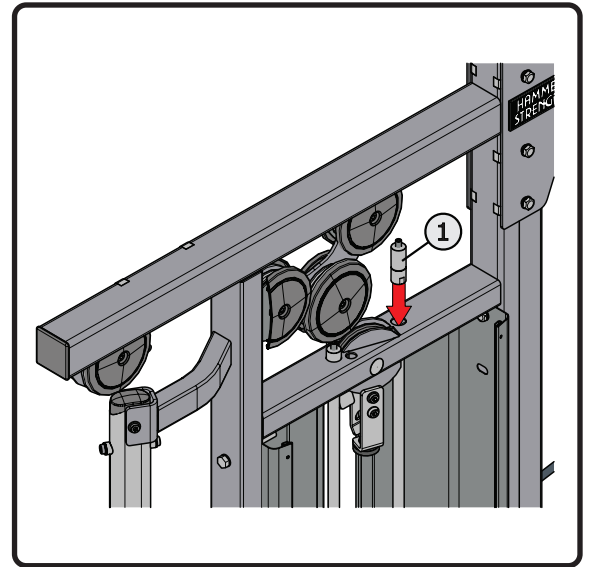

## REPLACE RETAINER RINGS

ITEM	QTY.	DESCRIPTION
1	2	RETAINER RINGS

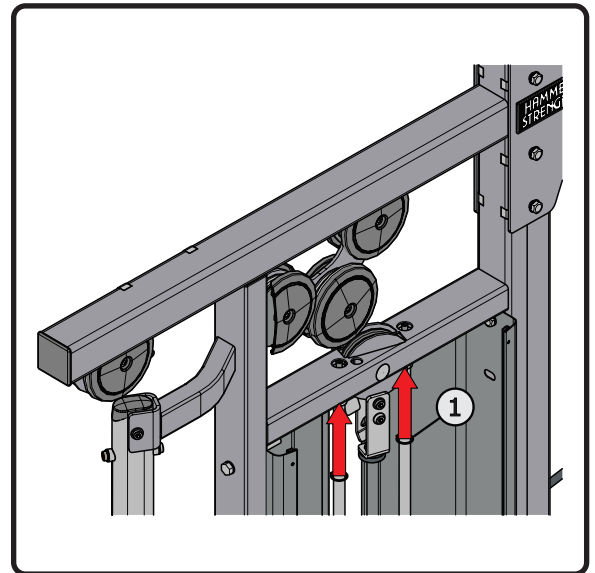

## TIGHTEN RETAINER SCREW

ITEM	QTY.	DESCRIPTION
1	2	RETAINER SCREW

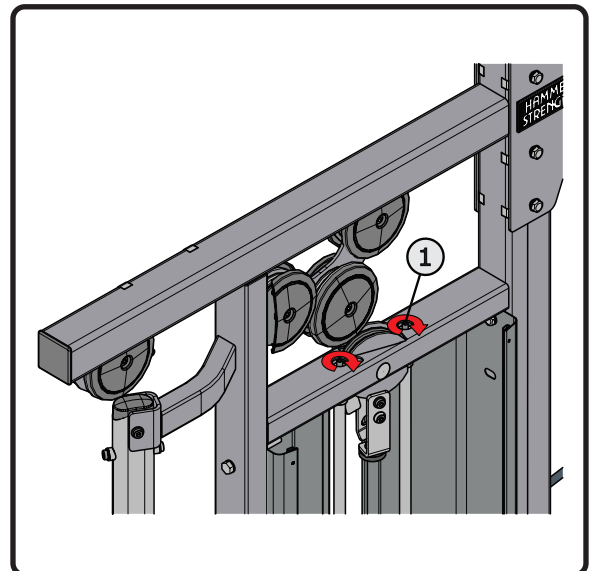

## TIGHTEN CABLE

ENSURE CABLE TERMINATIONS HAVE A MINIMUM ENGAGEMENT OF 1/2" (12.7mm).

TIGHTEN JAM NUTS:

20-25 FT-LBS (27.1-33.8Nm).

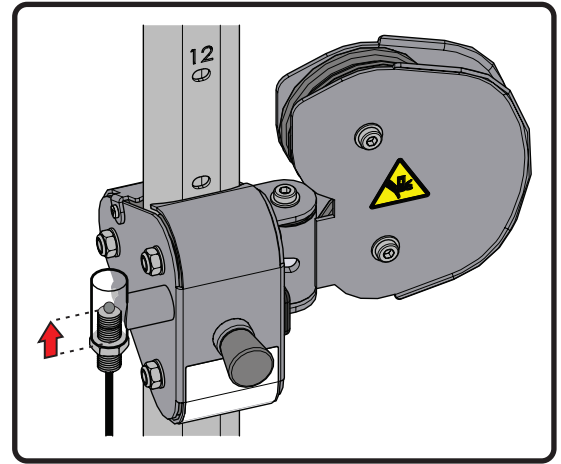
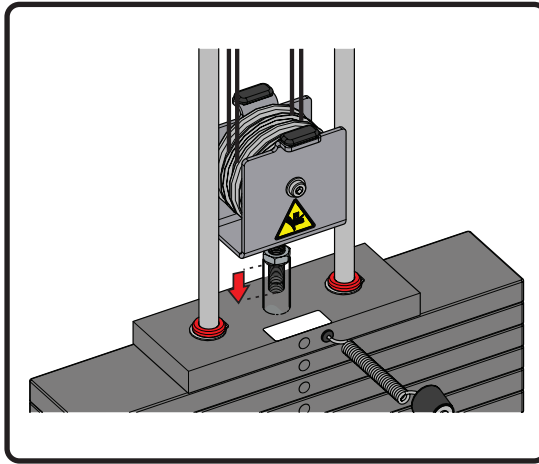

## REPLACE SHROUD

ITEM	QTY.	DESCRIPTION
1	4	RIVET
2	1	REAR SHROUD

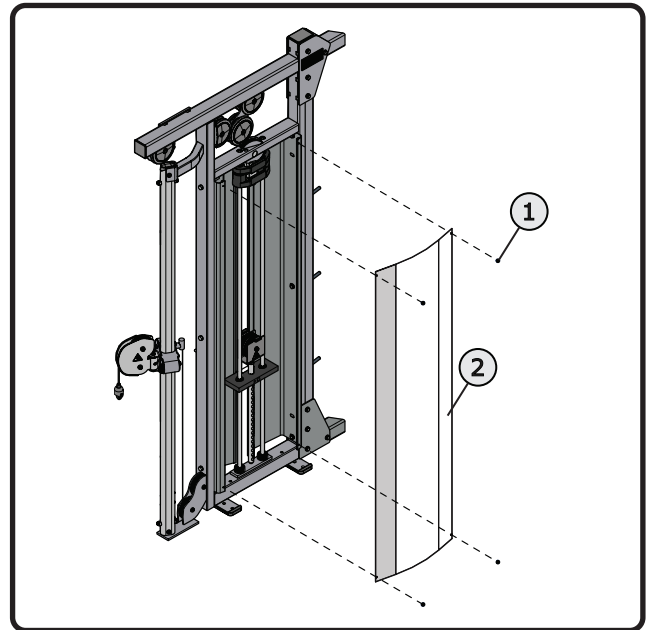

## ADD WEIGHT STACK LABELS

ITEM	DESCRIPTION
1	WS LABEL/POUNDS
	WS LABEL/KILOGRAMS

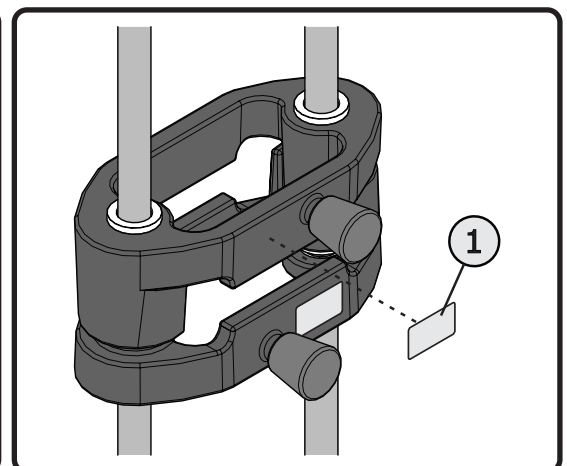
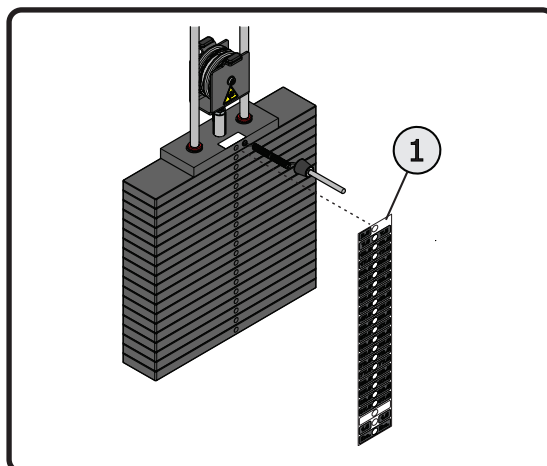

# STORAGE RACK INSTRUCTIONS

## HDLASR

### ASSEMBLE BASE

ITEM	QTY.	DESCRIPTION
A	8	3" RECTANGLE TUBING NUT
D	8	1/2" X 1-1/4" HEX HEAD BOLT
H	8	1/2" LOCK WASHER
1	4	HDL FOOT
2	4	RUBBER SLIPPER
3	1	BAR STORAGE WELDMENT
4	1	LEFT BASE ASSY.
5	1	RIGHT BASE ASSY.

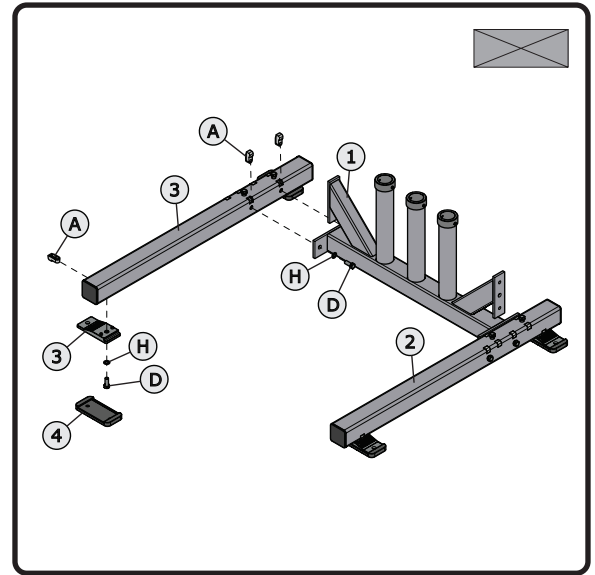

### ATTACH UPRIGHTS

ITEM	QTY.	DESCRIPTION
A	4	3" RECTANGLE TUBING NUT
D	4	1/2" X 1-1/4" HEX HEAD BOLT
H	4	1/2" LOCK WASHER
1	1	LEFT STORAGE UPRIGHT
2	1	RIGHT STORAGE UPRIGHT

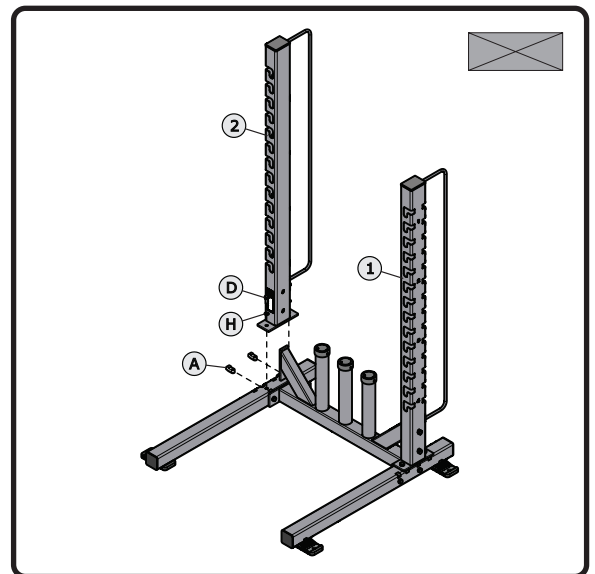

### ATTACH ANVIL PLATES

ITEM	QTY.	DESCRIPTION
A	4	3" RECTANGLE TUBING NUT
D	4	1/2" X 1-1/4" HEX HEAD BOLT
G	4	1/2" X 4" HEX HEAD BOLT W/ NYLOCK PATCH
H	4	1/2" LOCK WASHER
1	2	BOTTOM ANVIL PLATE

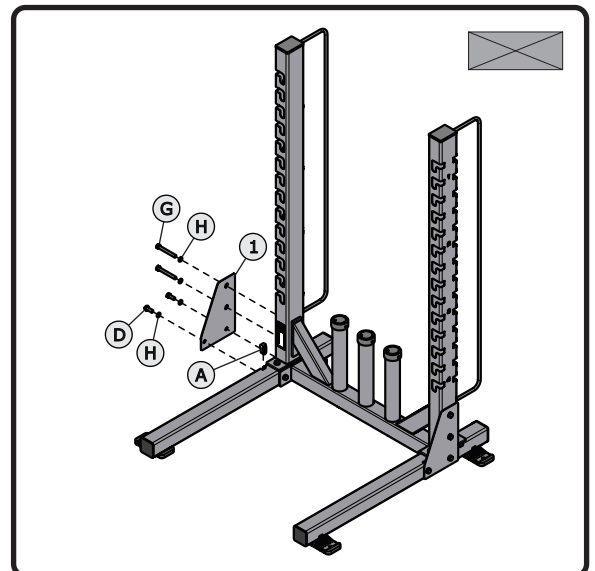

## OPTIONAL EQUIPMENT

### POWER PIVOT

- HR/MR/PR

ITEM	QTY.	DESCRIPTION
A	4	3" RECTANGLE TUBING NUT
D	4	1/2" X 1-1/4" HEX HEAD BOLT
H	4	1/2" LOCK WASHER
1	1/2	POWER PIVOT (ONE PER)

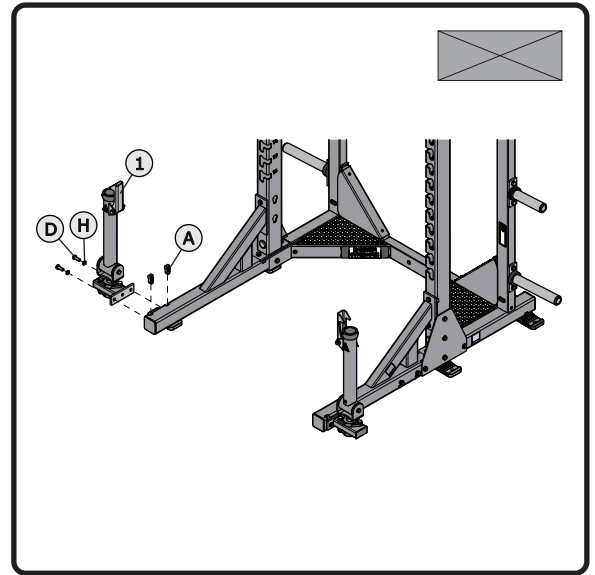

### BATTLE ROPE

- HR/MR/PR

ITEM	QTY.	DESCRIPTION
A	4	3" RECTANGLE TUBING NUT
D	4	1/2" X 1-1/4" HEX HEAD BOLT
H	4	1/2" LOCK WASHER
1	2	BATTLE ROPE WELDMENT (ONE PER)

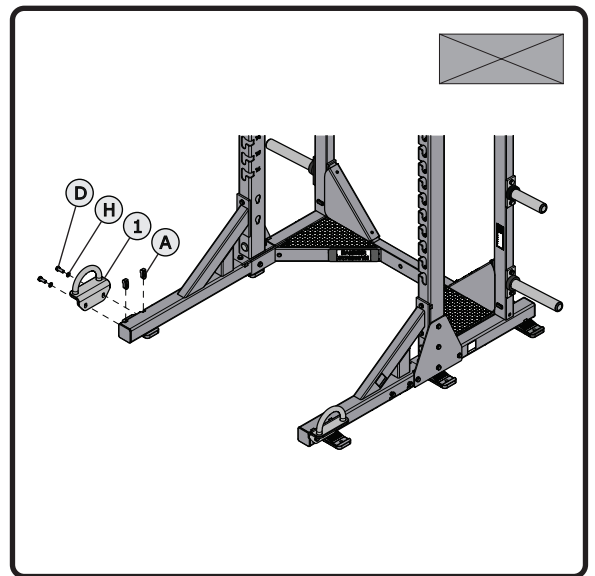

### SLIDING BAND PEG

- HRL

ITEM	QTY.	DESCRIPTION
A	4	3" RECTANGLE TUBING NUT
D	4	1/2" X 1-1/4" HEX HEAD BOLT
H	4	1/2" LOCK WASHER
1	2	SLIDING BAND PEG (2 PER)

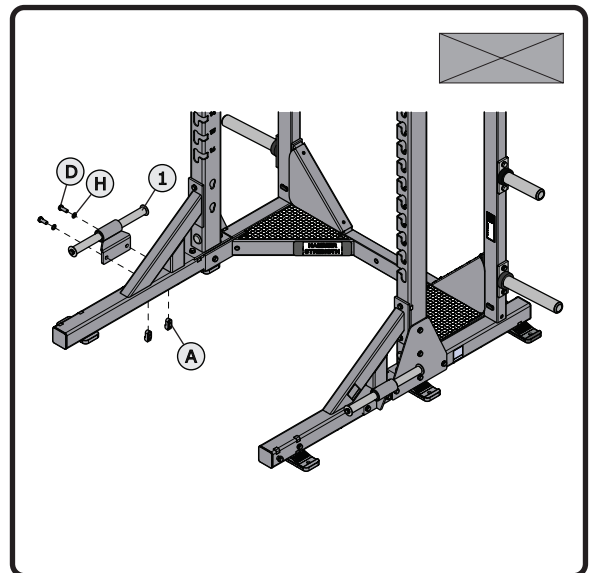

## BAR STORAGE

- HR/MR/PR

ITEM	QTY.	DESCRIPTION
D	4	1/2" X 1-1/4" HEX HEAD BOLT
H	4	1/2" LOCK WASHER
1	2	BAR STORAGE
2	2	LONG WEIGHT HORN

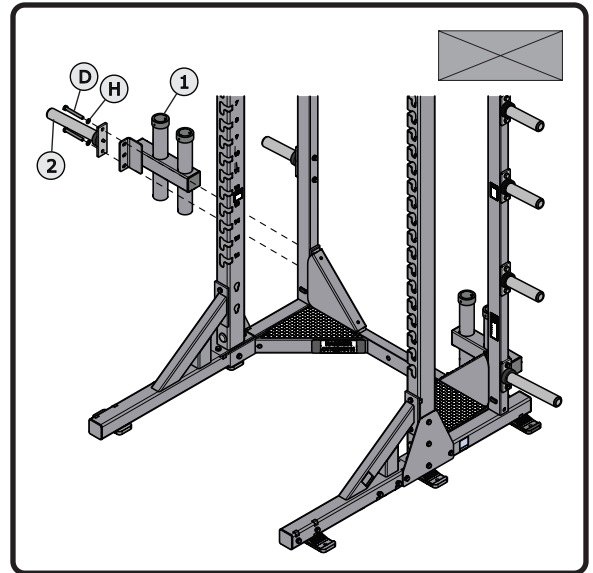

## BAR CATCH STORAGE

- HR/MR/PR

ITEM	QTY.	DESCRIPTION
G	4	1/2" X 4" HEX HEAD BOLT W/ NYLOCK PATCH
H	8	1/2" LOCK WASHER
I	4	1/2" THIN LOCK NUT
1	2	BAR CATCH STORAGE
2	2	BAR CATCH

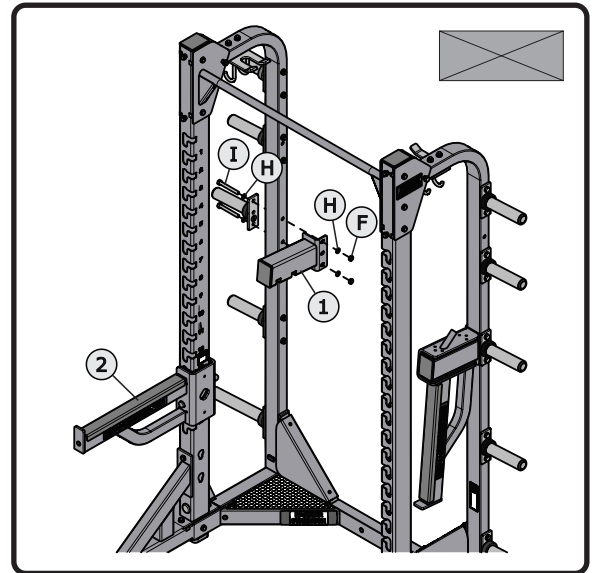

## SLS

- HR/MR/PR

ITEM	QTY.	DESCRIPTION
1	1	SLS ASSEMBLY

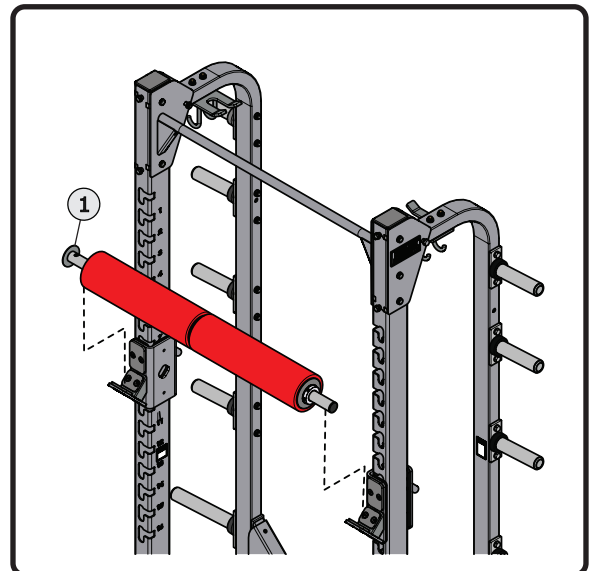

## UPPER BAND PEGS

- HR/MR/PR

ITEM	QTY.	DESCRIPTION
D	4	1/2" X 1-1/4" HEX HEAD BOLT
H	4	1/2" LOCK WASHER
1	2	UPPER BAND PEGS (L/R)

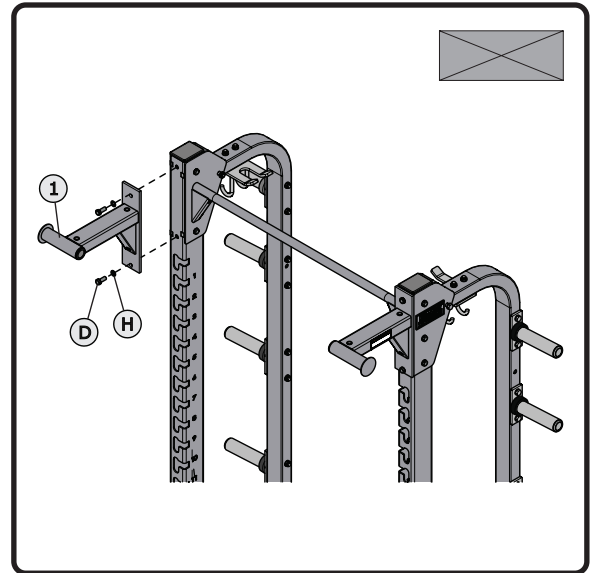

## DIP

- HR/MR/PR

ITEM	QTY.	DESCRIPTION
1	1	DIP HANDLE

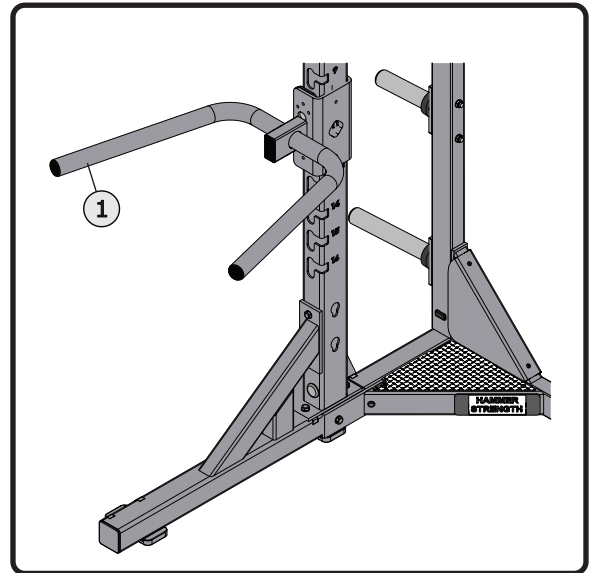

## BALL STORAGE WELDMENT

- HR/MR/PR

ITEM	QTY.	DESCRIPTION
D	2	1/2" X 1-1/4" HEX HEAD BOLT
H	2	1/2" LOCK WASHER
1	1	BALL STORAGE WELDMENT

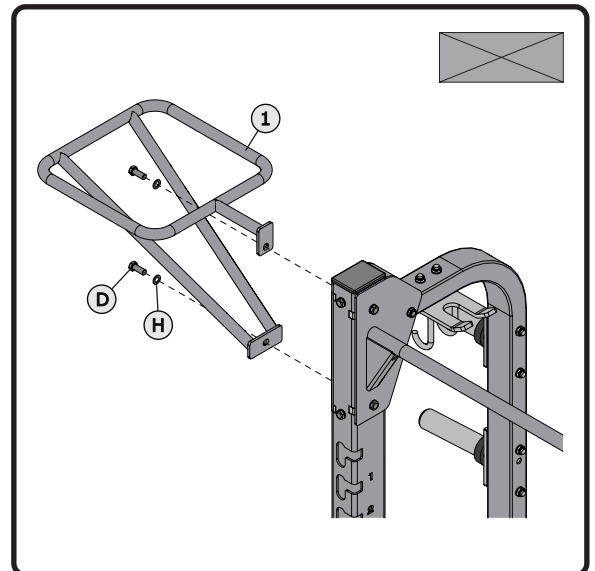

## TECHNIQUE TRAYS

- HR/MR/PR

ITEM	QTY.	DESCRIPTION
1	2	TECHNIQUE TRAYS

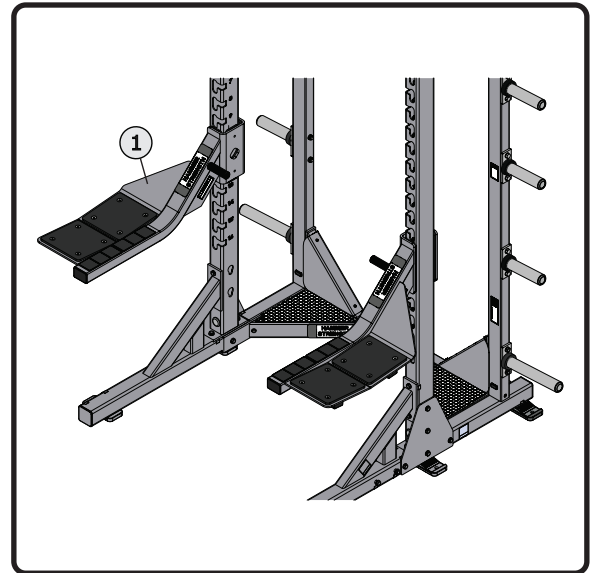

## STEP UP

- HR/MR/PR

ITEM	QTY.	DESCRIPTION
1	1	STEP UP

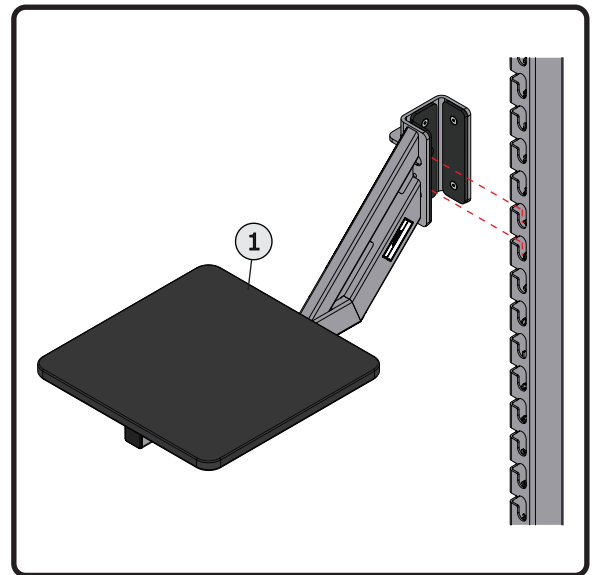

## SPOTTER PLATFORMS

- HR/MR/PR

ITEM	QTY.	DESCRIPTION
1	2	SPOTTER PLATFORMS

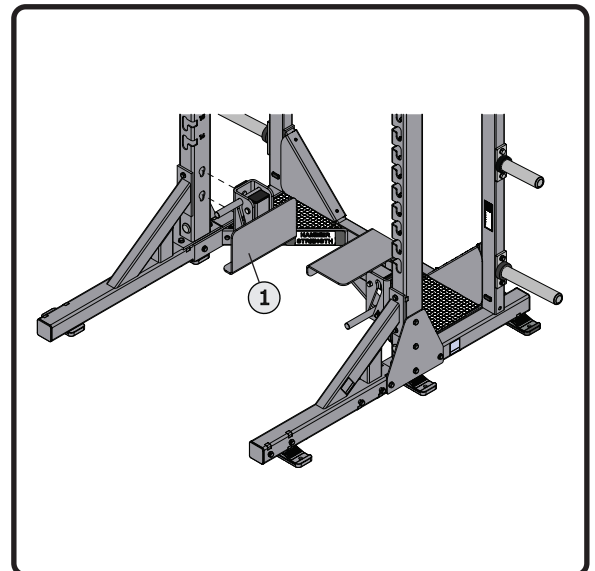

## BRANDING PLATE

- HR/MR/PR

ITEM	QTY.	DESCRIPTION
D	2	1/2" X 1-1/4" HEX HEAD BOLT
H	2	1/2" LOCK WASHER
1	1	BRANDING PLATE ASSY.

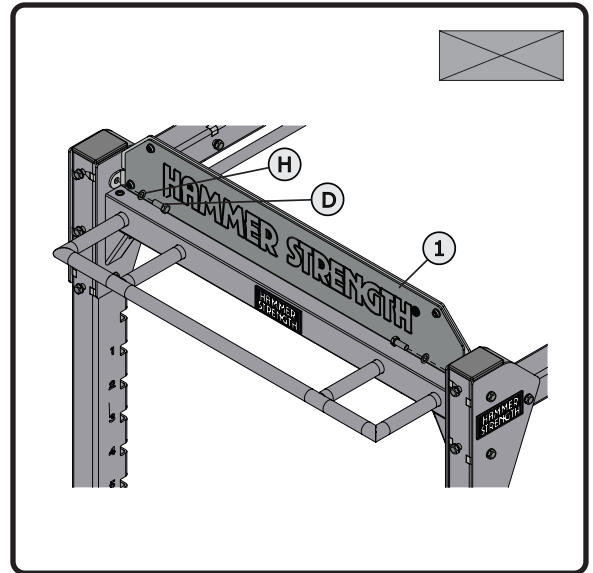

# OPTIONAL EQUIPMENT NORDIC HAMSTRING

- HR/MR/PR

## ATTACH HANGER

ITEM	QTY.	DESCRIPTION
H	4	1/2" LOCK WASHER
1	1	NORDIC HAMSTRING HANGER
2	-	WEIGHT HORN
3	2	1/2" X 4-1/2" HEX HEAD BOLT
4	2	1/2" THICK LOCK NUT

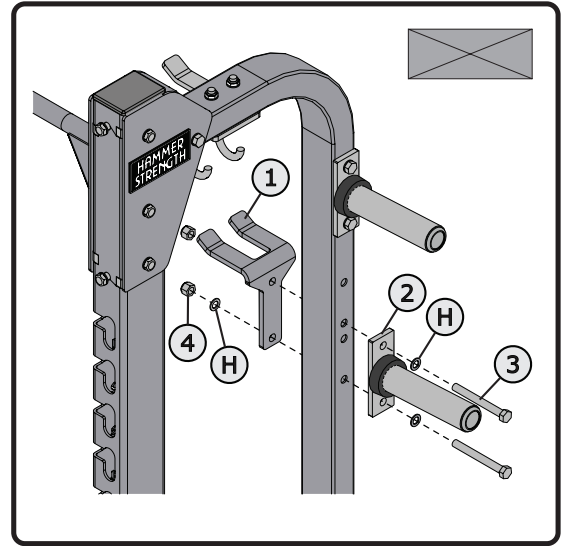

## ATTACH ANVIL PLATES

ITEM	QTY.	DESCRIPTION	ITEM	QTY.	DESCRIPTION
D	18	1/2" X 1-1/4" HEX HEAD BOLT	3	1	RIGHT REAR NORDIC PLATE*
H	18	1/2" LOCK WASHER	4	1	LEFT REAR NORDIC PLATE*
1	1	LEFT FRONT NORDIC PLATE*	5	1	NORDIC HAMSTRING ASSY.
2	1	RIGHT FRONT NORDIC PLATE*			

\* NOTE: PLATES COME IN PAIRS

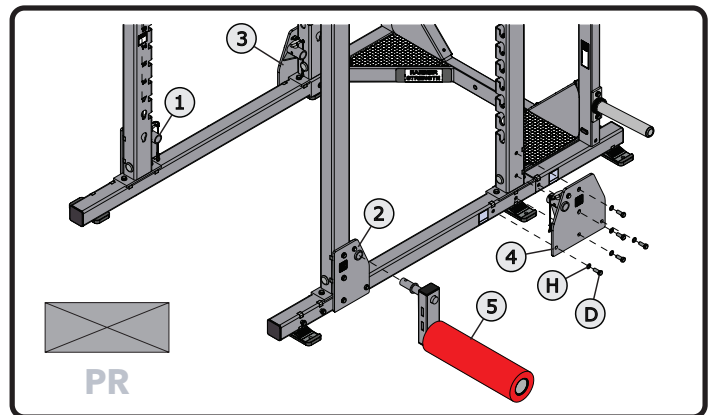
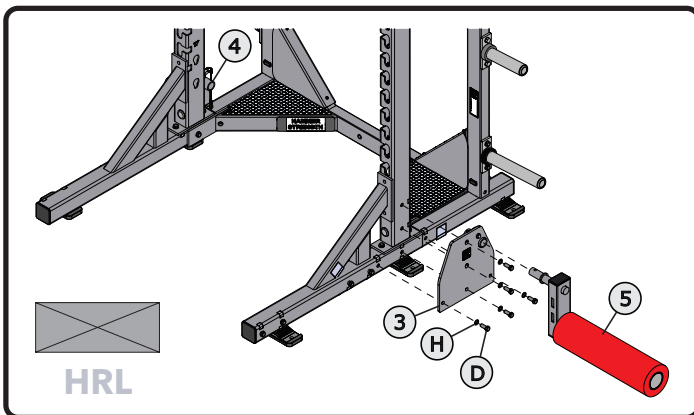
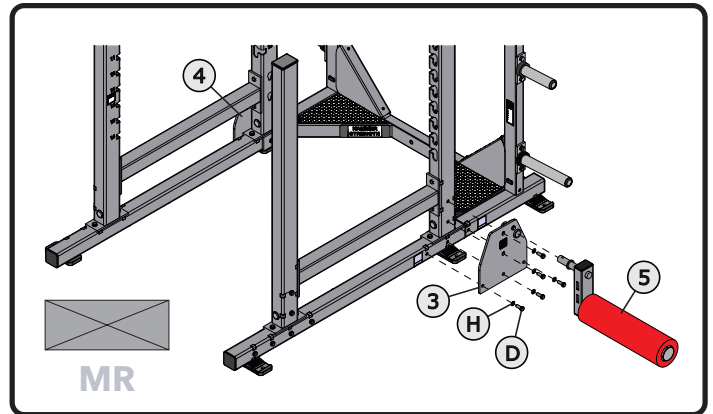
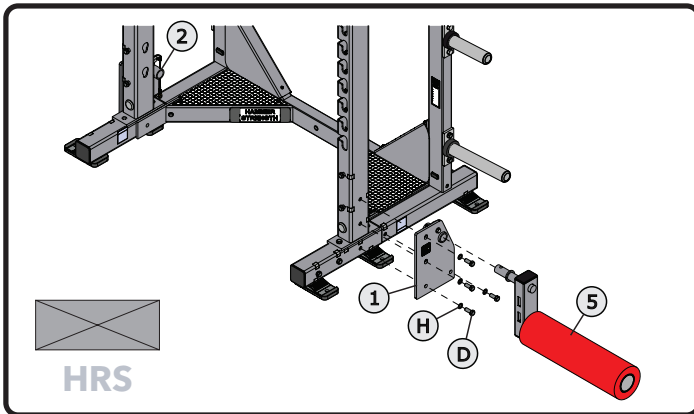

## OPTIONAL EQUIPMENT ROPE PULL

- HR/MR/PR

### ATTACH LOWER PULLEY

ITEM	QTY.	DESCRIPTION
A	2	3" RECTANGLE TUBING NUT
D	2	1/2" X 1-1/4" HEX HEAD BOLT
H	2	1/2" LOCK WASHER
1	1	LOWER PULLEY ASSEMBLY

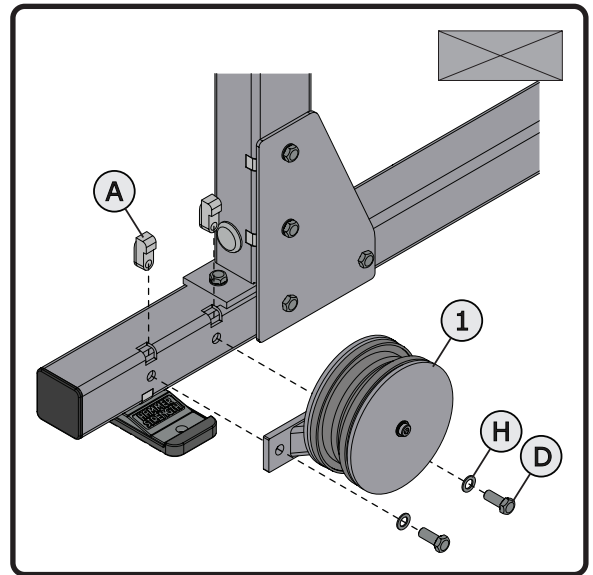

### ASSEMBLE UPPER PULLEY -RIGHT HAND SHOWN

ITEM	QTY.	DESCRIPTION
F	2	1/2" X 4" HEX HEAD BOLT
H	2	1/2" LOCK WASHER
I	2	1/2" THIN LOCK NUT
K	2	FENDER WASHER
1	1	RIGHT WING BRACE
2	1	UPPER PULLEY ASSEMBLY

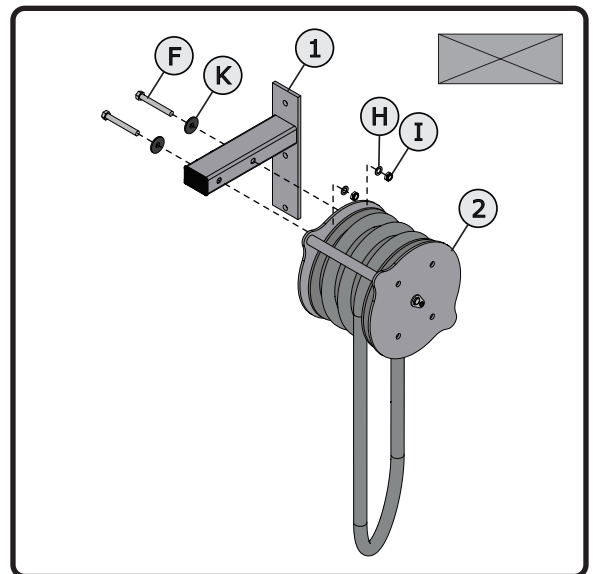

### ATTACH UPPER PULLEY

ITEM	QTY.	DESCRIPTION
D	3	1/2" X 1-1/4" HEX HEAD BOLT
H	3	1/2" LOCK WASHER
1	1	UPPER PULLEY ASSEMBLY

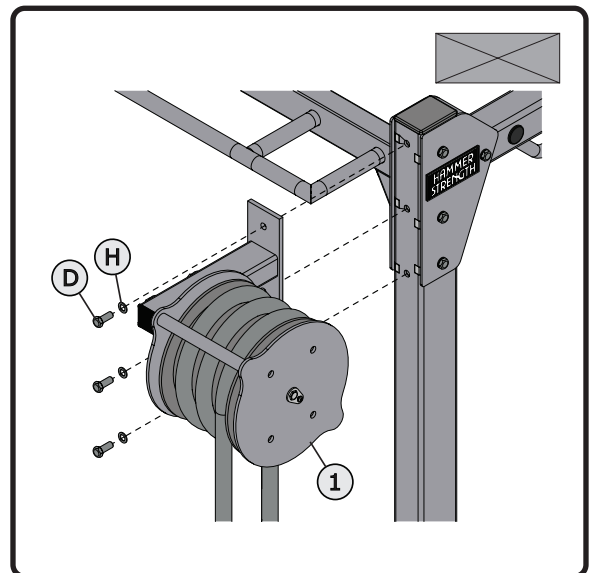

## OPTIONAL EQUIPMENT SLIDING BAND PEG

- HR/MR/PR

### REMOVE HOLE PLUGS

ITEM	QTY.	DESCRIPTION
1	4	HOLE PLUGS

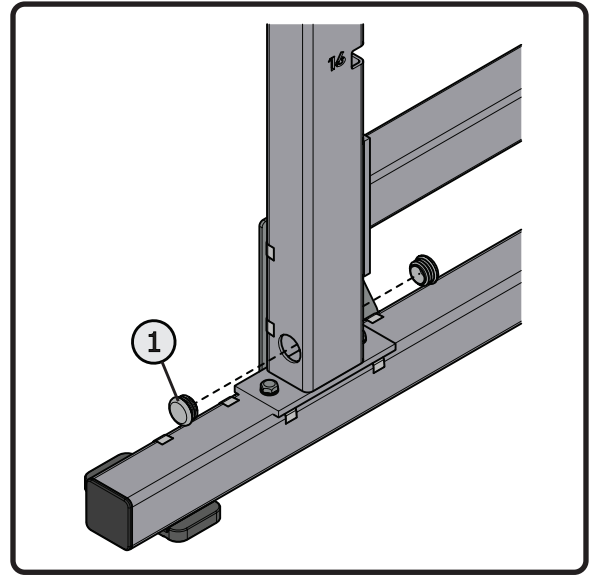

### ADD BUSHINGS

ITEM	QTY.	DESCRIPTION
1	1	PLASTIC BUSHINGS

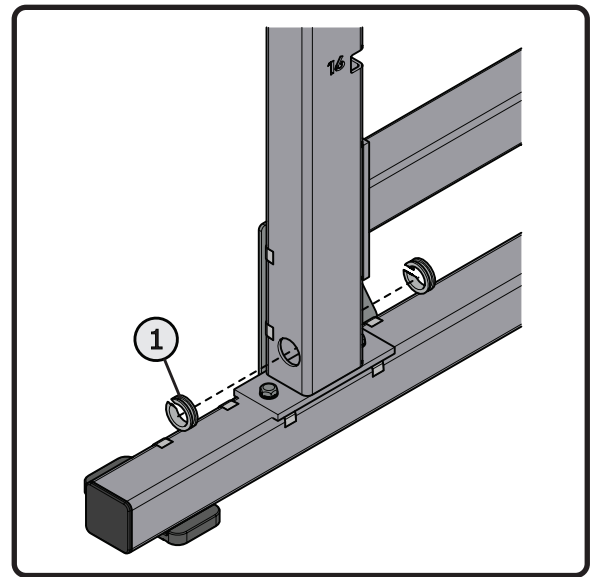

### ASSEMBLE TO RACK

ITEM	QTY.	DESCRIPTION
D	4	1/2" X 1-1/4" HEX HEAD BOLT
1	4	FENDER WASHER
2	2	SLIDING PEG

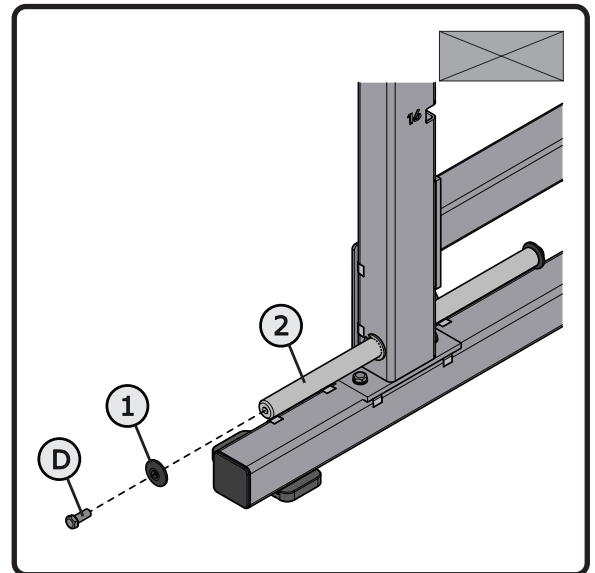

## OPTIONAL EQUIPMENT DOCK-N-LOCK

- HR/MR/PR

### REMOVE HOLE PLUGS

ITEM	QTY.	DESCRIPTION
1	4	HOLE PLUG

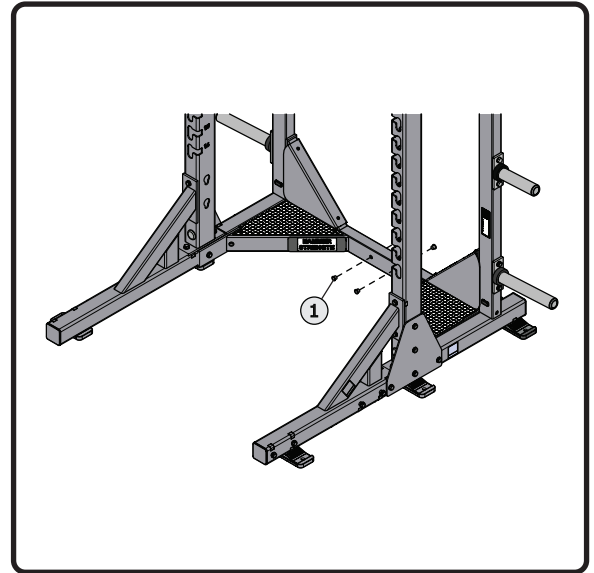

### ASSEMBLE TO RACK - NO PLATFORM

ITEM	QTY.	DESCRIPTION
L	2	1/2" X 3-1/2" HEX HEAD BOLT
H	2	1/2" LOCK WASHER
M	2	1/2" THICK LOCK NUT
K	2	FENDER WASHER
1	1	DOCK-N-LOCK WELDMENT

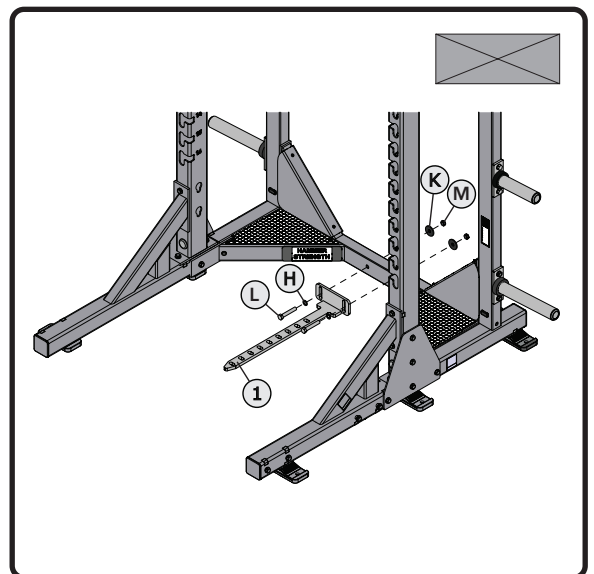

### ASSEMBLE TO RACK - WITH PLATFORM

ITEM	QTY.	DESCRIPTION
L	2	1/2" X 3-1/2" HEX HEAD BOLT
H	2	1/2" LOCK WASHER
M	2	1/2" THICK LOCK NUT
K	2	FENDER WASHER
1	1	DOCK-N-LOCK WELDMENT

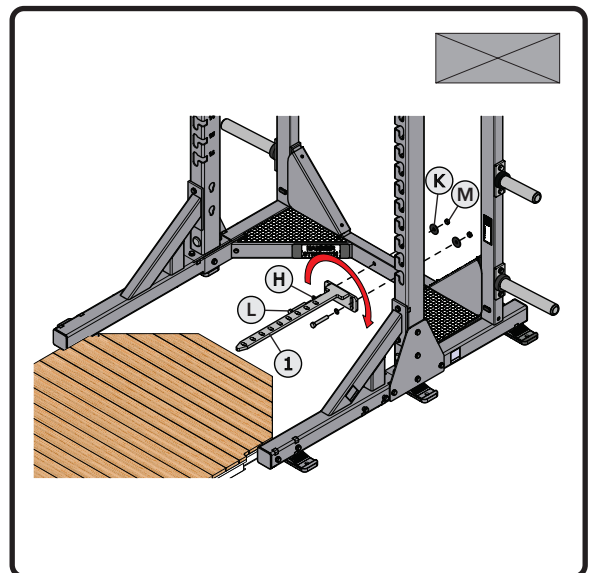

## OPTIONAL EQUIPMENT SAFETY SQUAT HANDLES

- HR/MR/PR

### ATTACH HANGER

ITEM	QTY.	DESCRIPTION
H	4	1/2" LOCK WASHER
1	1	HANGER WELDMENT
2	-	WEIGHT HORN
3	2	1/2" X 4-1/2" HEX HEAD BOLT
4	2	1/2" THICK LOCK NUT

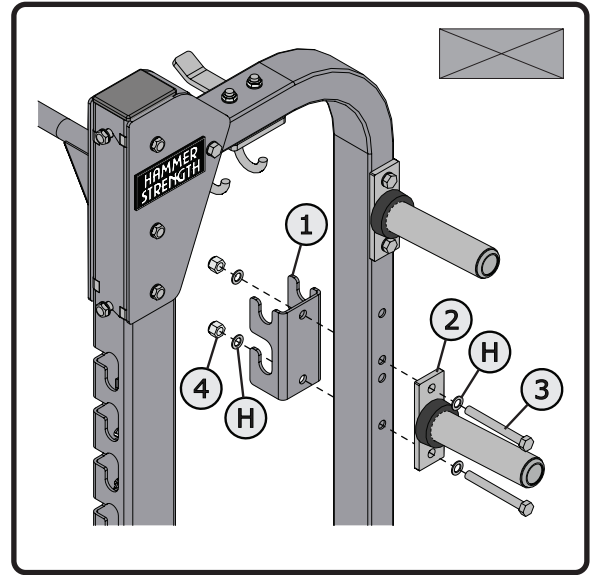

### PLACE SAFETY SQUAT HANDLES

ITEM	QTY.	DESCRIPTION
1	2	SAFETY SQUAT HANDLES

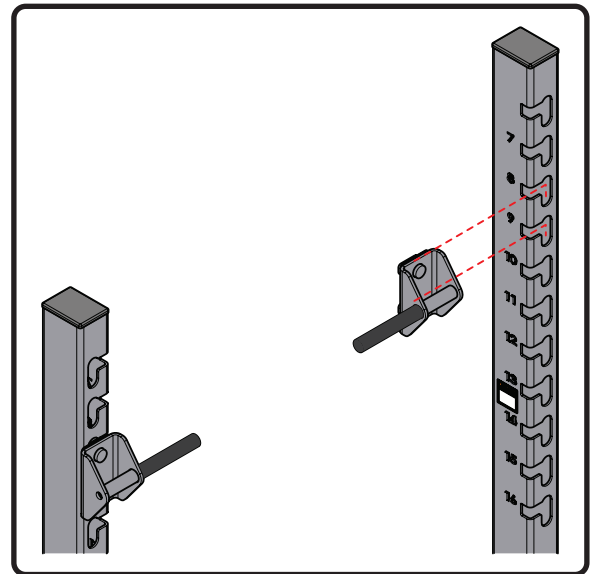

## OPTIONAL EQUIPMENT WING

- PR

### HANG RUNG

ITEM	QTY.	DESCRIPTION
A	2	3" RECTANGLE TUBING NUT
D	2	1/2" X 1-1/4" HEX HEAD BOLT
H	2	1/2" LOCK WASHER
1	1	WING RUNG

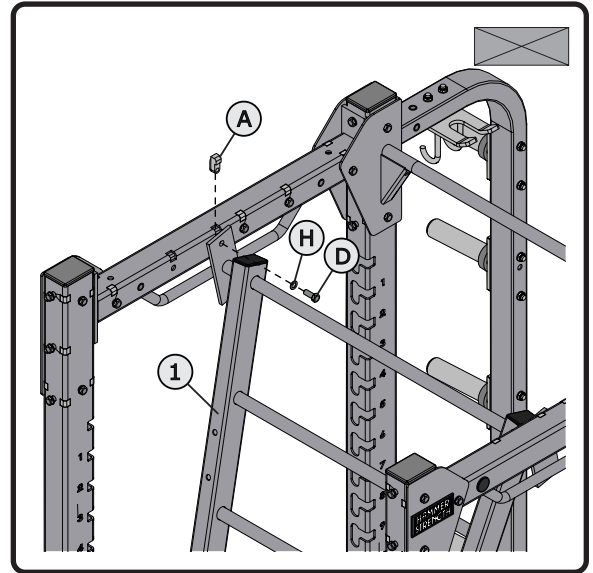

### RAISE RUNG/ATTACH BRACES

ITEM	QTY.	DESCRIPTION
A	2	3" RECTANGLE TUBING NUT
B	2	4" RECTANGLE TUBING NUT
D	6	1/2" X 1-1/4" HEX HEAD BOLT
H	6	1/2" LOCK WASHER
1	1	LEFT WING BRACE
2	1	RIGHT WING BRACE

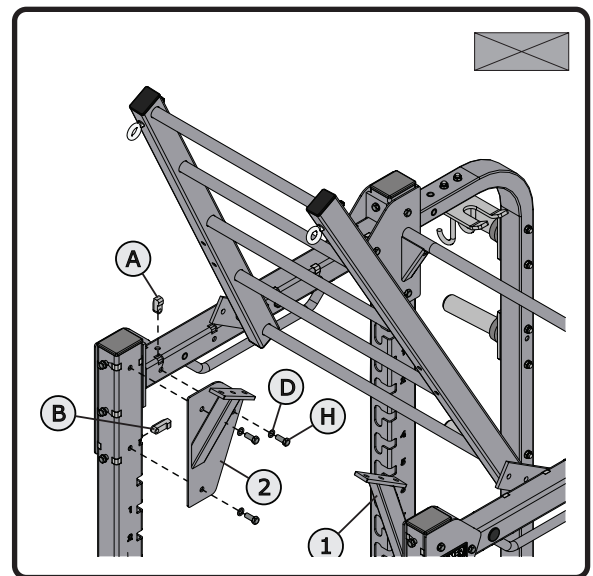

### LOWER RUNG/ATTACH

ITEM	QTY.	DESCRIPTION
A	2	3" RECTANGLE TUBING NUT
D	2	1/2" X 1-1/4" HEX HEAD BOLT
F	4	1/2" X 4" HEX HEAD BOLT
H	10	1/2" LOCK WASHER
I	4	1/2" THIN LOCK NUT

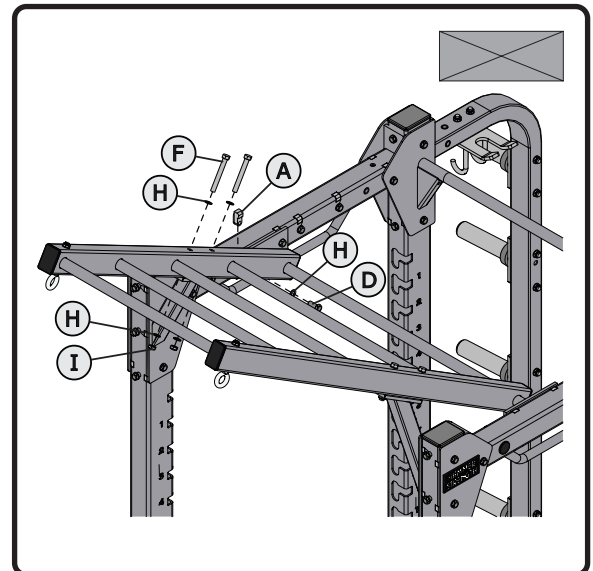

# OPTIONAL EQUIPMENT PERPENDICULAR BAND PEGS

- PR

## TYPES

ITEM	DESCRIPTION
1	PERP. BAND PEGS ASSY.
2	SUMO PERP. BAND PEGS ASSY.

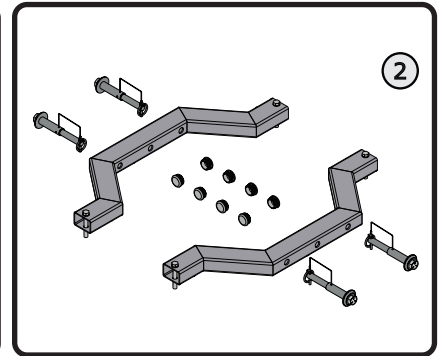
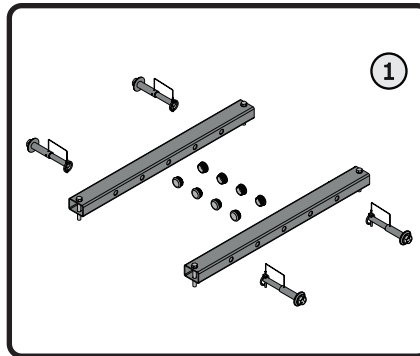

## INSTALL HOLE PLUGS

ITEM	QTY.	DESCRIPTION
1	8	HOLE PLUGS

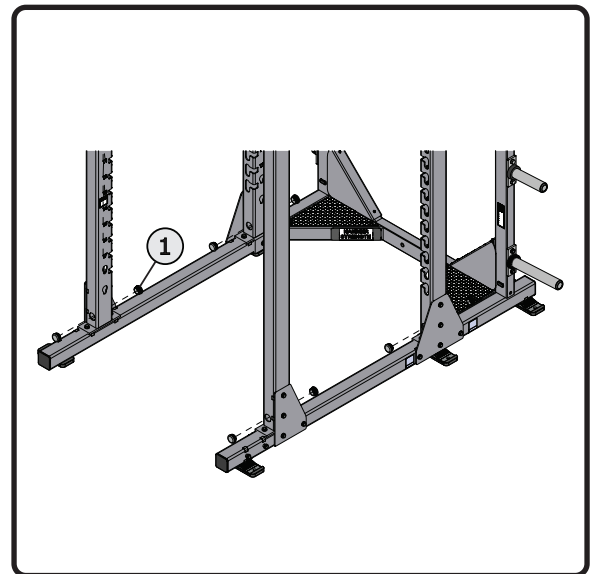

## ASSEMBLE WELDMENT

ITEM	QTY.	DESCRIPTION
H	4	1/2" LOCK WASHER
1	4	BAND PEG
2	4	1/2" X 3-1/2" HEX HEAD BOLT
3	2	BAND PEG WELDMENT

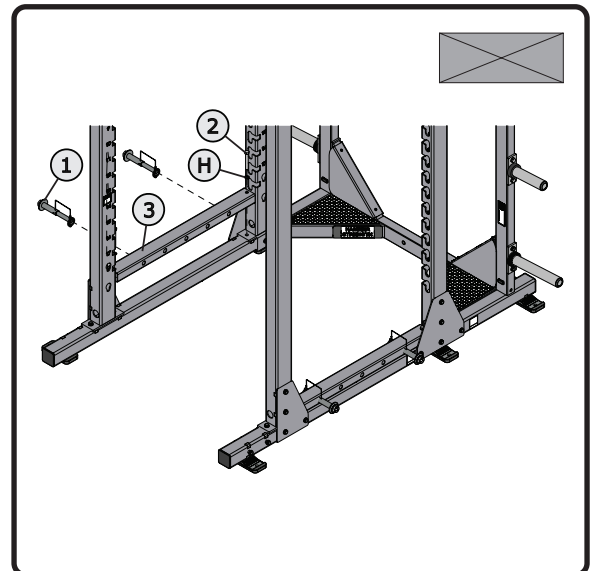

## OPTIONAL EQUIPMENT STRAP BAR CATCH

- PR

### ATTACH STRAP HANGER

ITEM	QTY.	DESCRIPTION
H	8	1/2" LOCK WASHER
1	2	HANGER WELDMENT
2	-	WEIGHT HORN
3	4	1/2" X 4-1/2" HEX HEAD BOLT
4	4	1/2" THICK LOCK NUT

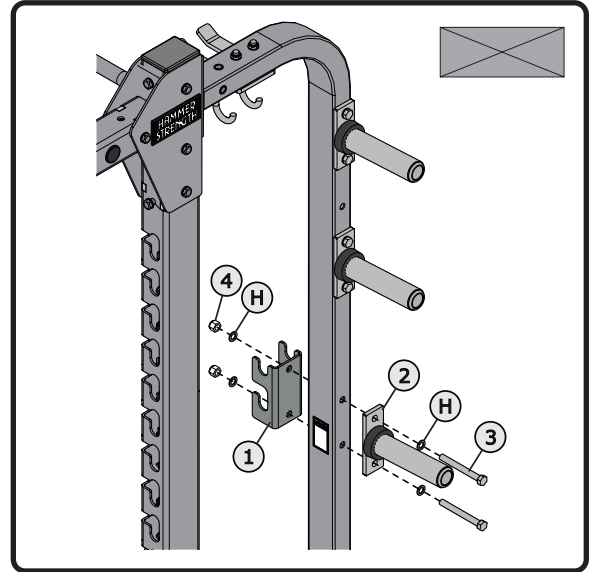

### PLACE STRAP CATCH

ITEM	QTY.	DESCRIPTION
1	2	STRAP CATCH

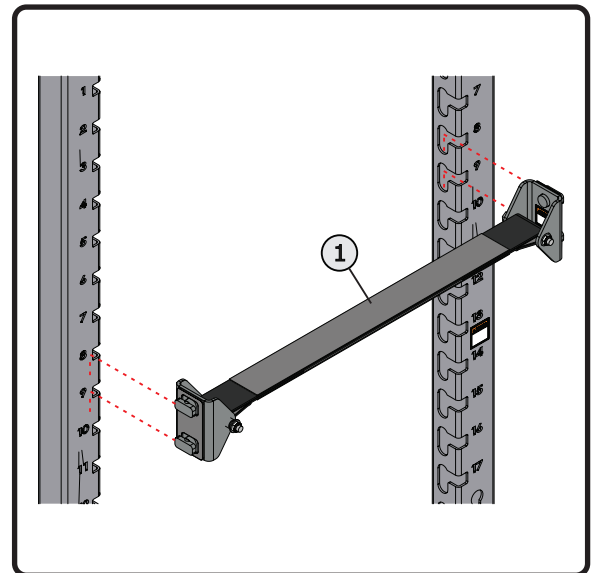

**OPTIONAL EQUIPMENT  
SIDE MOUNT PULL UP**

- PR

**REMOVE HOLE PLUGS**

ITEM	QTY.	DESCRIPTION
1	4	HOLE PLUGS
2	4	LARGE HOLE PLUGS

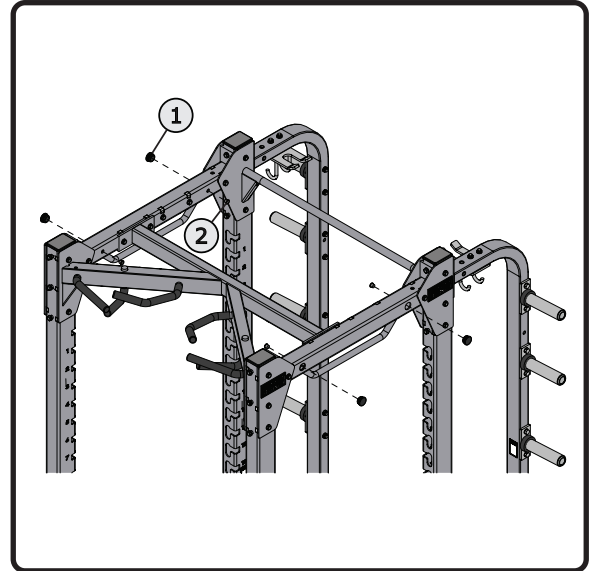

**ATTACH PULL UP**

ITEM	QTY.	DESCRIPTION
D	4	1/2" X 1-1/4" HEX HEAD BOLT
H	4	1/2" LOCK WASHER
1	2	SIDE MOUNT PULL UP

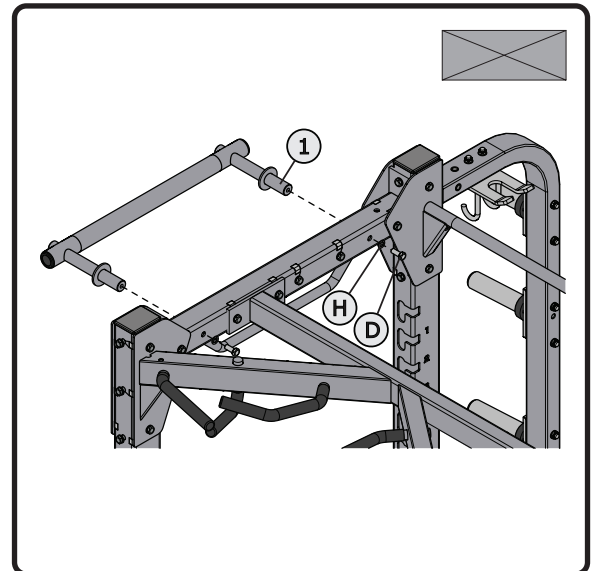

# 10 CABLE HANDLING GUIDE

## Cable Connections, Tensioning and Inspection

Cable connections with threaded cable ends are required to be installed and maintained following the specifications identified below. Failure to follow these specifications can lead to the dislocation of the threaded cable during use and can cause serious injury. Along with securing the threaded cable end and jam nut, it is important to check the entire unit and ensure that all hardware is securely fastened and not left loose upon completion of cable installation.

Use of non certified "techs" note: Service warranties may be void if a non-Life Fitness certified technician performs service work. Replacement of any strength cables should be performed by a Life Fitness certified technician.

## Tensioning Cable

Cables should have enough tension so it stays seated onto the pulley but not so tight that it pulls the head plate off the weight plates below it.





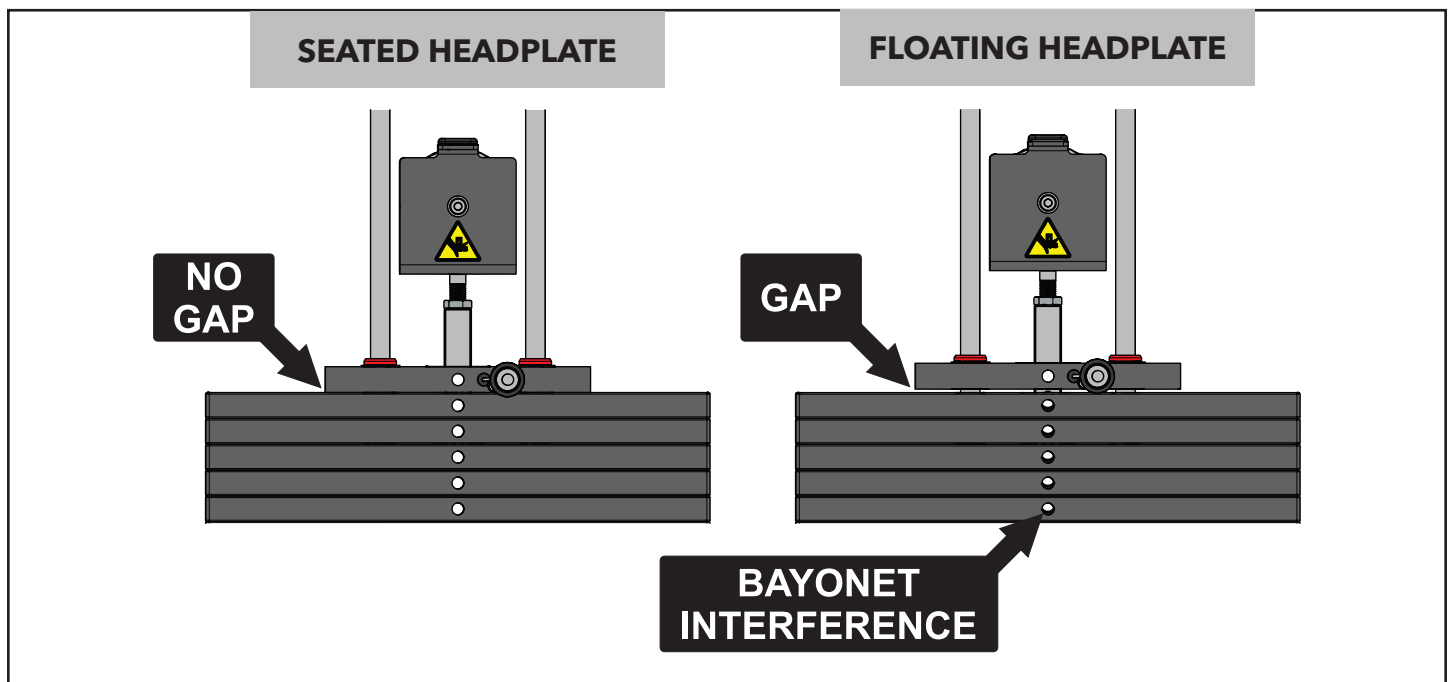

If headplate has lifted (floating):

1. Loosen the hardware at the terminations until the headplate comes to rest on the weight plate below.
2. Tighten hardware to 20-25 FT-LBS (27.2 - 34.0Nm).

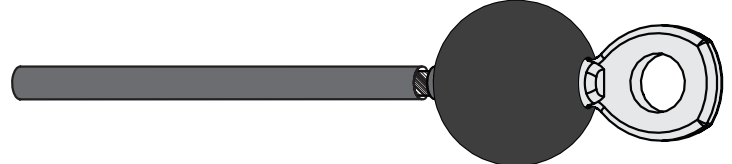

# Cable Inspection

Inspect cables daily and replace at first sign of wear or any of the following cable issues:

<p><b>FRACTURES</b></p>	
<p>Casing can crack, or fracture, under use. Any crack in the casing merits cable replacement even if no wire rope is exposed.</p>	
<p>Be especially observant for fractures near the components on the cable assembly. IE. Nylon Ball, Nico Loop, Threaded Plug, Etc.</p>	
<p><b>TWISTING</b></p>	
<p>Inspect casing to ensure wire rope is not twisting within its casing.</p>	
<p><b>BULGING</b></p>	
<p>Internal wire rope strands can break within casing and coil causing a bulge to appear. Cable should retain same outside diameter throughout.</p>	
<p><b>FRAYED/EXPOSED WIRE</b></p>	
<p>Any exposed wire rope protruding through the casing, or at either end.</p>	<p>Cable has 'kink' and prohibits it from laying flat</p>
<p><b>FLATTENED</b></p>	
<p>Section of cable is compressed and will not retain its shape (outside diameter).</p>	
<p><b>PERMANENTLY BENT</b></p>	
<p>Cable has 'kink' and prohibits cable from laying straight. Wire rope may be unravelling beneath casing and is compromised warranting replacement.</p>	
<p><b>ENDS SEPARATING</b></p>	
<p>Cable has 'kink' and prohibits it from laying flat</p>	

# 11 BOLT TO FLOOR GUIDELINES

## Introduction

Life Fitness designs its products to be stable when used as designed. Because strength training is dynamic, we cannot predict how users will ultimately use the products in all circumstances. Therefore, Life Fitness recommends that strength training equipment be secured to a solid, level surface to stabilize and eliminate rocking or tipping over. For some equipment, securing the equipment to the floor is REQUIRED.

- Any Half Rack with a load of 495 pounds (224kg) or greater.
- Any Half Rack Short Base (HDLHRS).
- Any rack with the optional Wing attached.
- Any unit that will be used with body weight strap training equipment, ropes, straps or chains in which case it is REQUIRED to be secured to the floor. Each new unit shipped comes with a multi-language hangtag stating the importance of bolting the unit down as a safety precaution.

It is the facility's responsibility to adhere to local and regional building codes.

### **ALL ANCHORS:**

- Fasteners must have minimum embedment in concrete floor, not including screed, regardless of wood/tile/rubber over subfloor. (See Anchor Selection for maximum subfloor thickness between unit and concrete to equipment foot must be made of flooring or other material (i.e. no air gaps)).
- DO NOT reuse fasteners. Static and Dynamic anchors are designed for one-time use only.
- Factor in equipment's feet height when selecting fastener length.
- Factor in flooring thickness when selecting fastener length.
- It is also recommended to drill an additional 1/2" (12.7mm) of depth beyond the length of the fastener being used to ensure that debris does not block the entry of the anchor.
- Minimum concrete compressive strength: 3000psi (20 N/mm<sup>2</sup>).

### **Anchoring**

- Life Fitness requires that each foot has at least one anchor bolted to the floor.
- All anchors must have a minimum embedment into concrete, regardless of wood/tile/rubber/screed over sub-floor.
- Dynamic anchors must have a minimum embedment depth in concrete to ensure maximum security and pull out force. See Anchor Selection for embedment depth minimums.

### **Building Codes**

- It is the facility's responsibility to adhere to local and regional building codes. Please verify with the customer to ensure that they are aware of this.

### **Carpeting**

- If bolted down to carpet flooring, be sure to use a box cutter knife to cut the carpet threads around each foot. This will help avoid the carpet threads from being wrapped around and pulled by the drill bit.

### Competitor Product

- The bolt down guidelines and procedures for Life Fitness products were determined by the company's Engineering and Installation Development groups. These guidelines include which anchors to use and positioning of the anchors are required for Life Fitness product.
- Life Fitness does not have that level of specification or engineering input for competitive product.
  - Life Fitness installation teams are not permitted to anchor competitor equipment.

### Drilling

- It is also recommended to drill an additional 1/2" (12.7mm) of depth beyond the length of the fastener being used to ensure that debris does not block the entry of the anchor.
- This can be done by marking your drill bit with a piece of tape.
  - While it is recommended that a vacuum be used to clean up debris, this will not account for all the debris that will settle at the bottom of the drilled hole.

### Anchor Types

PRODUCT	ANCHOR		Subfloor between unit and concrete 0" to 1/2" (12.7mm) thick	Subfloor between unit and concrete over 1/2" (12.7mm) thick
<ul style="list-style-type: none"> <li>HDL Racks <b>EXCEPT</b> Half Rack Short Base (HDL-HRS)</li> </ul>	Static	Imperial	KH-EZ 3/8" x 4"	KH-EZ 3/8" x 5"
		Metric	HUS-H 8mmx 120mm	HUS-H 8mmx 150mm
<ul style="list-style-type: none"> <li>Half Rack Short Base (HDLHRS)</li> <li>HDL Racks with optional Wing</li> </ul>	Dynamic	Imperial	HSL-3 M 8/40 LF p/n 9226402	HST M 12 x 115/20 to 295/200 (length depends on subfloor thickness)
		Metric		

## Anchor Specifications

DYNAMIC ANCHOR	Minimum Concrete Thickness	Minimum Drill Depth in Concrete	Minimum Concrete Embedment	Minimum concrete compressive strength
KH-EZ 3/8"	4-7/8" (124mm)	1/2" beyond anchor length	3-1/4" (83mm)	3000psi
HUS-H 8mm	120mm (4-3/4")	10mm beyond anchor length	75mm (2-3/32")	20 N/mm2
HSL-3 M/40	4-3/4" (120mm)	1/2" beyond anchor length	2-13/32" (60mm)	3000psi
HST M 12	140mm (5-1/2")	10mm beyond anchor length	70mm (2.8")	20 N/mm2

## Pullout Force

Life Fitness specifies Hilti™ static and dynamic anchors. According to the anchor manufacturer, the recommended design pullout force (in tension) for the specified anchors, when properly installed in cracked concrete, is provided in the side table. This table should be used for reference only; for additional and up-to-date information on the anchor capabilities or the design pullout force in other substrates, please consult Hilti directly at <https://www.us.hilti.com>.

SELECTED ANCHOR	DESIGN RESISTANCE IN TENSION
KH-EZ 3/8" x 4"	1535 lb
KH-EZ 3/8" x 5"	1535 lb
HUS-H 8mm x 120mm	3.3 kN
HUS-H 8mm x 140mm	3.3 kN
HSL-3/8 4"	2000 lb
HST M12 x 115/20	8 kN
HST M12 x 195/200	8kN

\* Design strength extracted from the Hilti Anchor Fastening Technology Manual issued September 2014.

## Tools Required

**WARNING!** Adhere to manufacturer's equipment warnings and guidelines. Follow manufacturer's instructions for proper usage.

Floor scanner/rebar detector (optional)	Safety glasses
1" L-shape SDS rotary hammer	Extension cord
1/4" x 12" (6mm x 305mm) carbide drill bit (for 1/4" (6mm) anchors)	Impact wrench
3/8" x 12" (8mm x 305mm) carbide drill bit (for 3/8" (8mm) anchors)	Vacuum (for debris)

## Static Anchor Procedure

If it is possible that the length of your bolt will not provide  
**CAUTION!** the minimum requirement of 2.5" (63.5mm) of engagement, a longer anchor should be used.

1. Place unit into position to be mounted and cycle unit to set stance.
2. Each foot **must** get at least one static fastener.
3. Wearing protective glasses, drill down into the flooring to the required depth as perpendicular as possible, ensuring that the foot thickness is being accounted for; refer to Anchor Selection and Foot Dimensions.
4. Insert fastener and tighten to 18 Foot-Pounds (24Nm) for 1/4" (6mm) anchor or 40 Foot-Pounds (54Nm) for 3/8" (8mm) anchor.

**NOTE:** If the legs/frame do not contact the mounting surface DO NOT pull down with the fastener or anchor. Loosen frame hardware and re-tighten to allow machine to align.

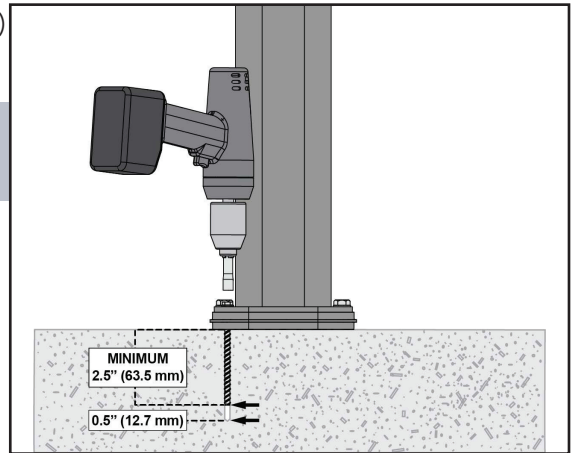
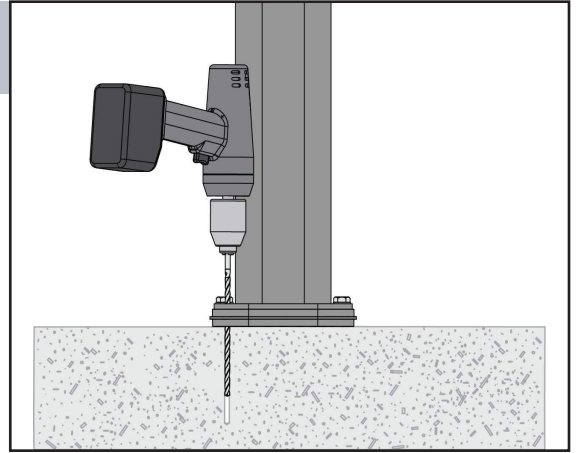

## Foot Dimensions

Use below to determine foot specifications.

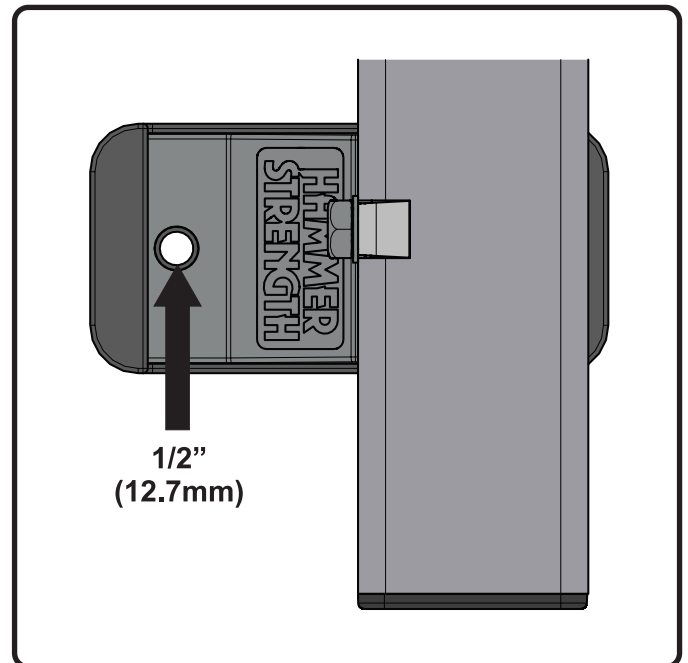
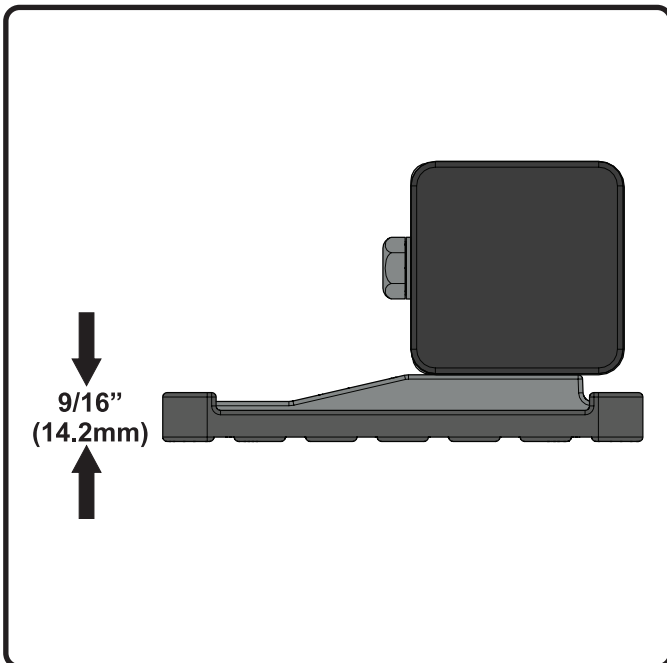

# 12 MAINTENANCE PROCEDURES

## Maintenance Schedule

ACTION	DAILY	WEEKLY	MONTHLY	AS NEEDED
<b>CLEAN</b>				
Upholstery	X			
Guide Rods			X	
Shrouds			X	
Hand Grips				X
<b>WAX</b>				
Frames				X
<b>INSPECT</b>				
Paint			X	
Cable	X			
Hardware		X		
Frame		X		
Hand Grips		X		
Shrouds	X			
<b>LUBRICATE</b>				
Guide Rods				X

### CLEAN...

1. Upholstery with an approved or compatible cleaner.
2. Guide Rods with a cotton cloth.
3. Hand Grips with an approved or compatible cleaner.

### WAX...

1. Frames with a standard, non-abrasive, wax finish.

### INSPECT...

1. Cables. Look for wear or damage and proper tension. Pay close attention at bends.
2. Hardware. Check for loosening. Tighten as required.
3. Frames. Inspect for wear and damage.
4. Handgrips. Check for wear and damage.
5. For paint chips. Fill in immediately with Life Fitness touch-up paint.

## LUBRICATE

Lubricate guide rods with Break-Free® brand lubricant (part number SK50-P0005-0000). Apply the lubricant to a cotton cloth, and then run the cotton cloth up and down the guide rods as needed. **NOTE:** *only a few drops of lubricant are required for each guide rod.*

## ONCE A DAY

1. Wipe down upholstery with a mild soap and water or comparable all purpose cleaner.
2. Visually inspect cables for wear at and around connections and along the entire length of the cable. Always replace at first sign of wear.

## ONCE A WEEK

1. Visually inspect all hardware for loosening, tampering or wear.
2. Check cable terminations for tightness and proper engagement.
3. Inspect all accessories, connecting links, and carabiner clips for wear.
4. Check condition of hand grips.
5. Inspect Shrouds for damage and clean as necessary.

## ONCE A MONTH

1. Clean Guide Rods with Break-Free® brand lubricant (part number SK50-P0005-0000). Clean tops of bearings at stack and inspect for heavy buildup on rods below the head plate. Lift half of stack and do a visual inspection, then clean as necessary.
2. Inspect hardware on all machines and tighten any bolts or nuts that may have loosened over the life of the product.

## NOTES

Use polishing compound (such as car wax) and remove shoe scuffs from powder coated surfaces as necessary.

## CLEANING THE SHROUDS

Adherence to regular and proper cleaning procedures is recommended to preserve the appearance.

## MINIMIZE SCRATCHES

Wash the shrouds with an approved or compatible cleaner. Do not scrub brushes on the shrouds. Fresh paint splashes, grease and smeared glazing compounds can be removed easily before drying by rubbing lightly with isopropyl alcohol. Afterward, a warm final wash should be made.

## **LIFE FITNESS APPROVED CLEANERS** *(United States Availability Only)*

Two preferred cleaners have been approved by LIFE FITNESS reliability experts: PureGreen 24 and Gym Wipes. Both cleaners will safely and effectively remove dirt, grime and sweat from equipment. PureGreen 24 and the Anti-bacterial Force formula of Gym Wipes are both disinfectants that are effective against MRSA and H1N1.

PureGreen 24 is available in a spray which is convenient for gym staff to use. Apply the spray to a microfiber cloth and wipe down the equipment. Use PureGreen 24 on the equipment for at least 2 minutes for general disinfection purposes and at least 10 minutes for fungus and viral control.

Gym Wipes are large, durable pre-moistened wipes to use on the equipment before and after workouts. Use Gym Wipes on the equipment for at least 2 minutes for general disinfection purposes.

Contact Customer Support Services to order these cleaners (1-800-351-3737 or email: customersupport@lifefitness.com).

## **LIFE FITNESS COMPATIBLE CLEANERS**

Mild soap and water or a mild non-abrasive household cleaner can also be used to clean the display and all exterior surfaces. Use a soft microfiber cloth only. Apply the cleaner to the microfiber cloth before cleaning. **DO NOT** use ammonia or acid based cleaners. **DO NOT** use abrasive cleaners. **DO NOT** use paper towels. **DO NOT** apply cleaners directly to the equipment surfaces.

## **REMOVAL OF PAINT, MARKING PEN AND LABELS**

Butyl cellosolve works well for removal of paints, marking pen inks, lipstick, etc.

Labels, stickers, etc. may be removed using kerosene. When the solvent will not penetrate sticker material, apply heat (hair dryer) to soften the adhesive and promote removal. **GASOLINE SHOULD NOT BE USED.**

## **IMPORTANT HAZARDS**

1. **DO NOT** use abrasive or highly alkaline cleaners on the shrouds.
2. **NEVER** scrape shrouds with squeegees, razor blades or other sharp instruments.
3. **DO NOT** clean shrouds in hot sun or at elevated temperatures.
4. **NEVER** use benzene, gasoline, acetone or carbon tetrachloride on the shrouds.

© 2017 Life Fitness, A division of Brunswick Corporation. All Rights Reserved. Life Fitness is a registered trademark of Brunswick Corporation. Gym Wipes® is a registered trademark of The 2XL Corporation. PureGreen 24 is a trademark of Pure Green , LLC.

Life Fitness World Headquarters  
Columbia Centre III  
9525 West Bryn Mawr Ave.  
Rosemont, IL 60018  
847-288-3300