

Bravo[®] 8800/8810

Owner's Manual

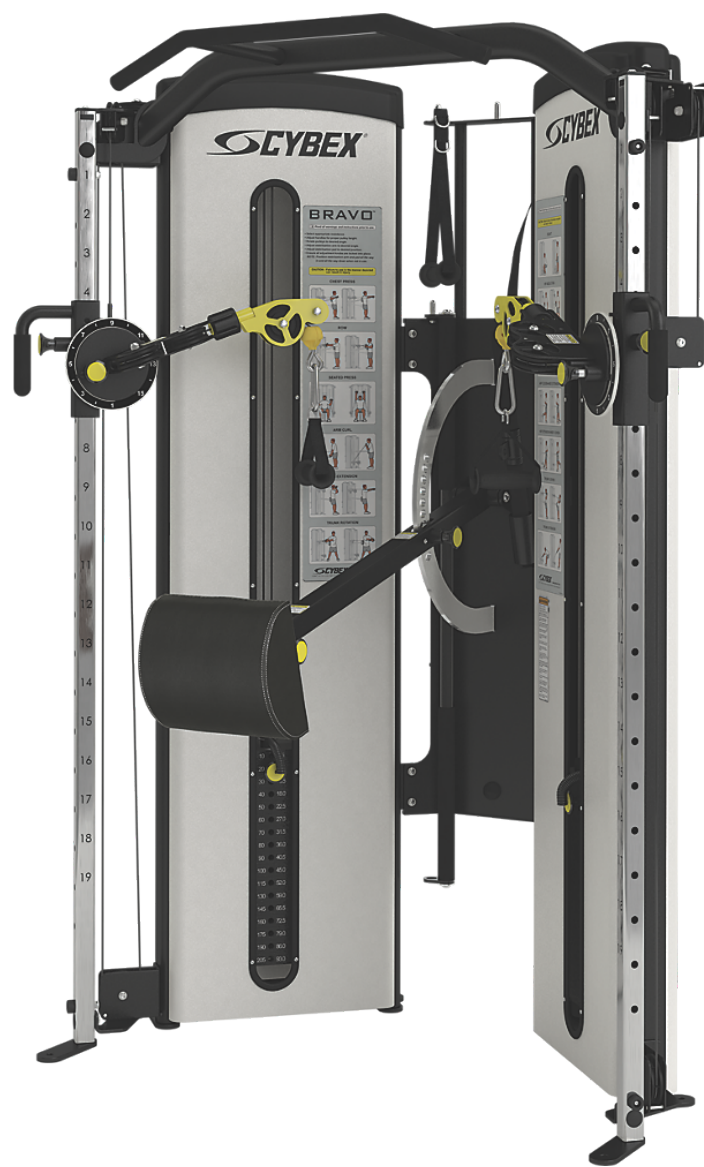

Part Number
8800-999-4 AD



Corporate Headquarters

Columbia Centre III, 9525 West Bryn Mawr Avenue, Rosemont, Illinois 60018 • U.S.A.

847.288.3300 • FAX: 847.288.3703

Service phone number: 800.351.3737 (toll-free within U.S.A., Canada)

Global Website: www.cybexintl.com

International Offices

AMERICAS North America

Cybox International Inc.

Columbia Centre III
9525 West Bryn Mawr Avenue
Rosemont, IL 60018 U.S.A.
Telephone: (847) 288 3300
Service Email: customersupport@lifefitness.com
Sales/Marketing Email: commercialsales@lifefitness.com

Brazil Life Fitness Brasil

Av. Rebouças, 2315
Pinheiros
São Paulo, SP 05401-300
BRAZIL
SAC: 0800 773 8282 option 2
Telephone: +55 (11) 3095 5200 option 2
Service Email: suportebr@lifefitness.com
Sales/Marketing Email: vendasbr@lifefitness.com

Latin America and Caribbean* Life Fitness, Inc.

Columbia Centre III
9525 West Bryn Mawr Avenue
Rosemont, IL 60018 U.S.A.
Telephone: (847) 288 3300
Service Email: customersupport@lifefitness.com
Sales/Marketing Email: commercialsales@lifefitness.com

EUROPE, MIDDLE EAST, and AFRICA (EMEA) Netherlands and Luxemburg

Life Fitness Atlantic BV

Bijdorplein 25-31
2992 LB Barendrecht
THE NETHERLANDS
Telephone: (+31) 180 646 666
Service Email: service.benelux@lifefitness.com
Sales/Marketing Email: marketing.benelux@lifefitness.com

United Kingdom Life Fitness UK LTD

Queen Adelaide
Ely, Cambs, CB7 4UB
Telephone: General Office (+44) 1353.666017
Customer Support (+44) 1353.665507
Service Email: uk.support@lifefitness.com
Sales/Marketing Email: life@lifefitness.com

Germany, Austria, and Switzerland Life Fitness Europe GMBH

Neuhofweg 9
85716 Unterschleißheim
GERMANY
Telephone:
+49 (0) 89 / 31775166 Germany
+43 (0) 1 / 6157198 Austria
+41 (0) 848 / 000901 Switzerland
Service Email: kundendienst@lifefitness.com
Sales/Marketing Email: vertrieb@lifefitness.com

Spain Life Fitness IBERIA

C/Frederic Mompou 5,1ª1ª
08960 Sant Just Desvern Barcelona
SPAIN
Telephone: (+34) 93.672.4660
Service Email: servicio.tecnico@lifefitness.com
Sales/Marketing Email: info.iberia@lifefitness.com

Belgium Life Fitness Benelux NV

Parc Industriel de Petit-Rechain
4800 Verviers
BELGIUM
Telephone: (+32) 87.300.942
Service Email: service.benelux@lifefitness.com
Sales/Marketing Email: marketing.benelux@lifefitness.com

All Other EMEA Countries and Distributor Business EMEA*

Bijdorplein 25-31
2992 LB Barendrecht
THE NETHERLANDS
Telephone: (+31) 180 646 644
Service Email: EMEAServiceSupport@lifefitness.com

ASIA PACIFIC (AP) Japan

Life Fitness Japan, Ltd

4-17-33 Minami Aoyama 1F/B1F
Minato-ku - Tokyo 107-0062
Japan
Telephone: (+81) 0120.114.482
Fax: (+81) 03-5770-5059
Service Email: service.lfj@lifefitness.com
Sales/Marketing Email: sales@lifefitnessjapan.com

Hong Kong Life Fitness Asia Pacific LTD

32/F, Global Trade Square
21 Wong Chuk Hang Road
Hong Kong
Telephone: (+852) 2575.6262
Service Email: Service.HK@lifefitness.com
Sales/Marketing Email: hongkong.sales@lifefitness.com

All Other Asia Pacific countries and distributor business Asia Pacific*

32/F, Global Trade Square
21 Wong Chuk Hang Road
Hong Kong
Telephone: (+852) 2575.6262
Fax: (+852) 2575.6894
Service Email: Service.AP@lifefitness.com
Sales/Marketing Email: Marketing.HK.Asia@lifefitness.com

*Also check www.cybexintl.com for local representation or distributor/dealer

Table of Contents

Safety

Safety Guidelines and Practices.....	5
Anchoring Equipment.....	5
Facility Safety Precautions.....	5
User Safety Precautions.....	6
Warnings and Cautions.....	7
Label Placement.....	8

Assembly

Machine Specifications.....	9
Choosing and Preparing a Site.....	9
Environment.....	9
Verify parts list shown below.....	10
Tools Required.....	11
Assembly Procedure.....	11

Exercise

Intended Use.....	17
Instructions.....	17

Maintenance

Warnings.....	20
Daily Procedures.....	20
Weekly Procedures.....	21
Yearly Procedures.....	23
Cable Adjustment.....	23

Warranty

What is Covered.....	25
Who is Covered.....	25
Who Pays Transportation and Insurance For Service.....	25
What We Will Do To Correct Covered Defects.....	25
What is Not Covered.....	25
Owner's Manual.....	25
Exclusive Warranty.....	25
Changes in Warranty Not Authorized.....	25
Effects of State Laws.....	26
Warranty Coverage.....	26

Cybox® and the Cybox logo are registered trademarks of Cybox International, Inc. Bravo® and its mark are registered trademarks of Cybox International, Inc.

DISCLAIMER: Cybox International, Inc. makes no representations or warranties regarding the contents of this manual. We reserve the right to revise this document at any time or to make changes to the product described within it without notice or obligation to notify any person of such revisions or changes.

© Copyright 2019, Cybox International, Inc.

Columbia Center III - 9525 West Bryn Mawr Ave, Rosemont, IL 60018 • 800-351-3737 • 847-288-3700 • FAX 800-216-8893

www.cyboxintl.com • 8800-999-4 AD • 2019

Safety

Safety Guidelines and Practices

 **TIP:** Read the Owner's Manual carefully before assembling, servicing, or using the equipment. Owner must comply with all safety guidelines in this manual. It is also the owner's responsibility to instruct users on the safe and proper operation of the equipment and to properly display any and all warning labels and instructional placards. All users should read these labels and placards before using equipment.

 **WARNING:** Serious injury or death could occur if the following safety precautions and instructions are not followed.

 **WARNING:** This product can expose you to chemicals including Di-isobutyl Phthalate, which is known to the State of California to cause birth defects or other reproductive harm, and Antimony Trioxide, which is known to the State of California to cause cancer. For more information go to <http://www.P65Warnings.ca.gov>

Anchoring Equipment

Owner should not allow equipment to be used until it is properly anchored as described below.

-  **WARNING:** Anchoring equipment:
- To maximize stability and eliminate rocking, tipping, or falling over, equipment must be anchored to a solid, level surface, utilizing all anchoring holes provided.
 - Fasteners must have a minimum of 500 lbs. tensile capacity. Cybex recommends .3/8" grade 2 bolts or better. A minimum pull force of 220 lbs/100 kgs is required for each anchor position.
 - If leg frames do not contact surface, DO NOT pull down with anchors. Shim any leg or frame not in contact with surface using flat washers.
 - Due to the wide variation of flooring on which machines may be anchored or installed, consult with a qualified and licensed contractor to ensure proper anchoring and installation.

Facility Safety Precautions

Do not allow anyone, including trainers, to use equipment in a manner other than that shown on the warning labels and instructional placards located on every machine.

Do not install equipment on an uneven surface. The solid, level surface should not deviate more than 1/8" over a 10' distance or as defined and required by local building and architectural codes.

It is the responsibility of the facility owner/owner of the equipment to ensure that there is appropriate clearance around each machine to allow for safe use and passage.

In compliance with the ADA (American Disabilities Act) there must be clear floor space of at least 30 by 48 inches and be served by an accessible route for at least one of each type of exercise equipment. If the clear space is enclosed on three sides (e.g., by walls or the equipment itself), the clear space must be 36 by 48 inches.

All other machines must have a clear floor space of 23" for all access point on the machine, unless shown in the Owner's Manual.

The dimensions stated in the assembly instructions of this manual include the maximum foot print (in use) dimensions.

All equipment should be used in a supervised, access-controlled area.

Do not allow equipment to be used by children 12 and under. Supervise disabled and children 13 and older.

The owner should ensure that regular inspection and maintenance checks as detailed in this manual are performed. Keep a log of all maintenance and repair activities.

Each day before use, the owner should inspect the equipment. If there are any loose or worn components such as belts, cables, grips, pulleys, or any missing, damaged labels, or placards, the owner should fix any deficiencies before they allow the equipment to be used.

Use only Cybex components to maintain and repair the equipment.

Display the Facility Safety Sign so it is visible and prominent.

User Safety Precautions

Owners must instruct users to DO the following:

- Follow all warning labels and instructional placards when using equipment.
- Insert weight pin completely before using selectorized equipment.
- Consult a physician prior to commencing an exercise program. If at any time during exercise you feel faint, dizzy or experience pain, stop and consult your physician.
- Use a spotter for Free Weight equipment.

Owners must instruct users to NOT DO the following:

- **DO NOT** pin weights on selectorized equipment in an elevated position or use the machine if found in this position
- **DO NOT** increase weight resistance on equipment by any means other than those provided by Cybex.
- **DO NOT** wear loose or dangling clothing or jewelry while using equipment. Stay clear of moving parts.
- **DO NOT** lean or pull on machine
- **DO NOT** use machine for support during stretching.
- **DO NOT** attach resistance straps, ropes or other means to equipment, except those provided by the manufacturer for intended use on the equipment.
- **DO NOT** exceed the maximum specified user weight.
- **DO NOT** use if equipment appears damaged or inoperable upon inspection
- **DO NOT** use if guards are missing or damaged.
- **DO NOT** remove any labeling from equipment.

Warnings and Cautions

Warning labels indicate a potentially hazardous situation that could result in serious injury or death if the precautions are not observed.

Caution labels indicate a potentially hazardous situation that could result in serious injury or damage to machine if the precautions are not observed.

Contact [Customer Support Services](#) to replace any worn or damaged labels.

⚠ WARNING

To minimize risk of serious injury:

Prior to use:

- Obtain a medical exam before beginning any exercise program.
- Obtain instruction before using.
- Read and understand warning labels. 
- Fully insert adjustment pins before using.
- Inspect machines and attachments before use. **DO NOT** use if the machine or attachments appear to be damaged. **DO NOT** attempt to fix broken or jammed machine or damaged attachments. Notify staff immediately.

During use:

- Use only as shown on instructional placard.
- Do not use for stretching and do not attach straps or other devices.
- Do not modify unit.
- Do not allow children 12 or younger to be on or near unit.
- Notify floor staff if weight plate is raised. **DO NOT USE.**
- Stop exercise if you feel faint, dizzy, or have pain.
- Use a spotter.

Do not remove this label. Replace if damaged or illegible.

DE000001-4 AB

⚠ CAUTION

To avoid injury, be sure pin is fully inserted into adjustment hole before use.

8500-025-4 B

⚠ CAUTION

To minimize risk of injury, do not sit or stand on stabilization pad or arm.

8800-442-4 B

⚠ CAUTION

Pinch hazard.
Keep hands and fingers away when weight stack is elevated.

DE000005-4



Label Placement

The following diagram shows where each label is located.

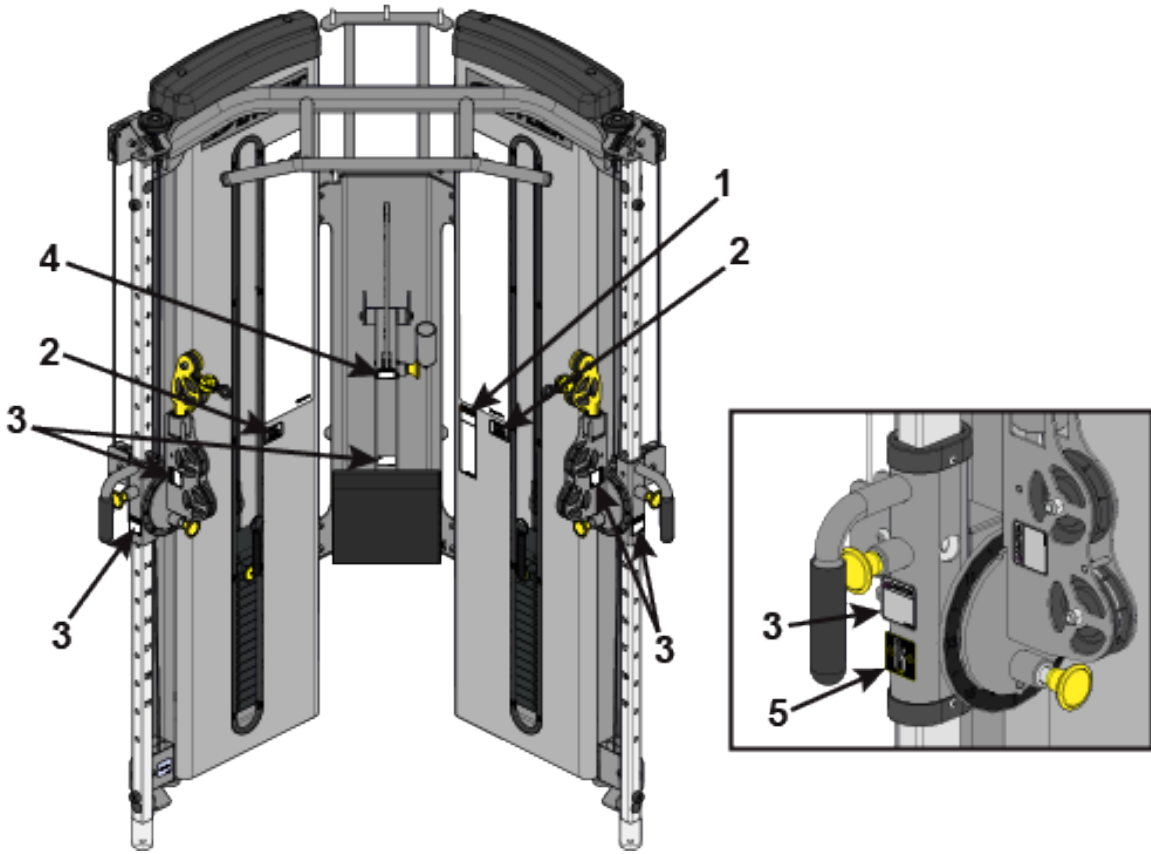

Item	Description	Qty
1	DE000001-X	1
2	DE000005-X	2
3	8500-025-X	8
4	8800-442-X	1
5	1011940-0001	2

Assembly

Machine Specifications

Total Weight and Size: 8800/8810 Bravo

Dimensions/Weight	8800 At Use And At Rest	8810 At Use And At Rest
L x W x H	45" L 54" W x 77" H	45" L 54" W x 87" H
L x W x H	114 cm L x 137 cm W x 196 cm H	114 cm L x 137 cm W x 221 cm H
Machine Weight	866 lbs (393 kg)	901 lbs (407 kg)

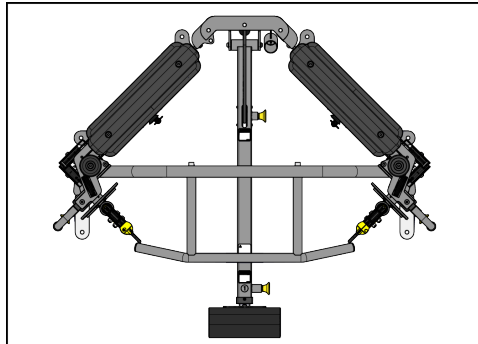

Maximum User Weight	Maximum Training Weight
300 lbs/135kg	350 lbs/159 kg

Choosing and Preparing a Site

Before assembling the unit, verify the chosen site meets the following criteria:

- Area is well lit and well ventilated.
- Surface is structurally sound and properly leveled.
- Free area for access to unit and emergency dismount. Minimum clearance is 23.6 inches (0.6 meters).
- Adjacent units may share the free area.

It is the responsibility of the facility owner/owner of the equipment to ensure that there is appropriate clearance around each machine to allow for safe use and passage.

In compliance with the ADA (American Disabilities Act) there must be clear floor space of at least 30 by 48 inches and be served by an accessible route for at least one of each type of exercise equipment. If the clear space is enclosed on three sides (e.g., by walls or the equipment itself), the clear space must be 36 by 48 inches.

All other machines must have a clear floor space of 23" for all access point on the machine, unless shown in the Owner's Manual.

Environment

Humidity and Static Electricity

The unit is designed to function normally in an environment with a relative humidity range of 30% to 75%. The unit can be shipped and stored in a relative humidity range of 10% to 90%.





Climatic dry air may cause static electricity. During workout, user may experience a shock due to build up of static electricity on the body and the discharge path of the unit. If static electricity is experienced, increase humidity to a comfortable level through the use of a humidifier.

Do not install, use or store the unit in an area of high humidity, such as in the vicinity of a steam room, sauna, indoor pool or outdoors. Exposure to extensive water vapor, chlorine and/or bromine could adversely affect other parts of the unit.

Temperature

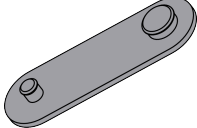
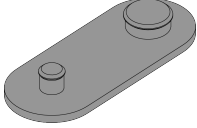
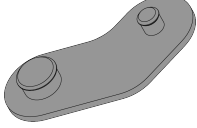
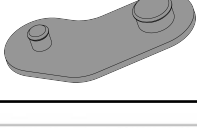
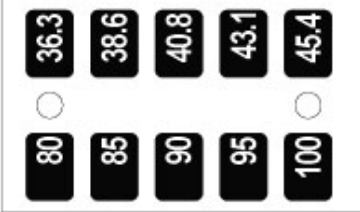
The unit is designed to function normally in an environment with an ambient temperature range of 50° F (10° C) to 104° F (40° C). The unit can be shipped and stored in an environment with an ambient temperature range of 32° F (0° C) to 140° F (60° C).

Verify parts list shown below

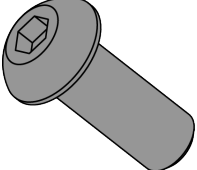
Qty	Part Number	Description	Diagram
2	12090-322	Foot Pad 6.25" × 2.00"	
2	13000-353	Foot Pad 5.00" × 2.00"	
1	13000-354	Foot Pad	
1	13000-355	Foot Pad	
1	DE000007	Decal, Standard 80-100 (Included with weight pack 13000-038)	
16	4700-337	Weight Plate (standard stack) (Included with weight pack 13000-038)	
1	DE000006	Decal, Standard 5-75 (Included with weight pack 13000-038)	
1	8810-101	8810 Chin Up Bar	
4	HC700417	BHSCS .375-16 × 1.00 (Included with 8810-101)	

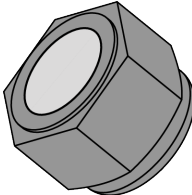
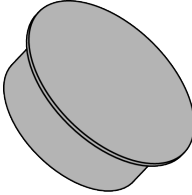
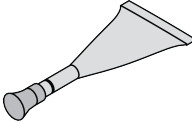
Qty	Part Number	Description	Diagram
2	HN704901	Locknut .375-16, Nylon (Included with 8810-101)	
2	PN660200	Insert, Plastic 1.00 Dia-11G (Included with 8810-101)	
1	YA000201	Loctite #242 (Included with 8810-101)	

Tools Required

- 9/16" Wrench
- 7/32" Allen wrench
- 3/4" Socket wrench
- Hammer
- 3/16" Pin punch
- Loctite® #242

Assembly Procedure

Two people will be required for this procedure.

 **TIP:** Read and understand all instructions thoroughly before assembling this unit. Check all items carefully. If there is damage, see the Customer Service section of this manual for proper procedure to return, replace, or reorder parts.

If machine CAN fit through doorway

Two people will be required for this procedure

1. Move to desired location.
2. Remove shipping cones using a 3/4" socket or wrench.
3. Remove bolt from shipping cone with hammer. Recycle cone. 
4. Attach foot pads to each foot of frame.
5. If weight stack needs to be installed, follow procedure for installing weight plates and weight plate decal.

Securely anchor machine to floor

Owner should not allow equipment to be used until it is properly anchored as described below.



WARNING: Anchoring equipment:

- To maximize stability and eliminate rocking, tipping, or falling over, equipment must be anchored to a solid, level surface, utilizing all anchoring holes provided.
- Fasteners must have a minimum of 500 lbs. tensile capacity. Cybex recommends .3/8” grade 2 bolts or better. A minimum pull force of 220 lbs/100 kgs is required for each anchor position.
- If leg frames do not contact surface, DO NOT pull down with anchors. Shim any leg or frame not in contact with surface using flat washers.
- Due to the wide variation of flooring on which machines may be anchored or installed, consult with a qualified and licensed contractor to ensure proper anchoring and installation.

Verify proper operation

If machine CANNOT fit through doorway

Two people will be required for this procedure

1. Remove shipping cones using a 3/4” socket or wrench.
2. Remove bolt from shipping cone with hammer. Recycle cone. 
3. Attach foot pads to each foot of frame.
4. Remove the two Button Head Socket Cap Screws (BHSCS) securing the top cap to the frame using a 7/32” Allen wrench.

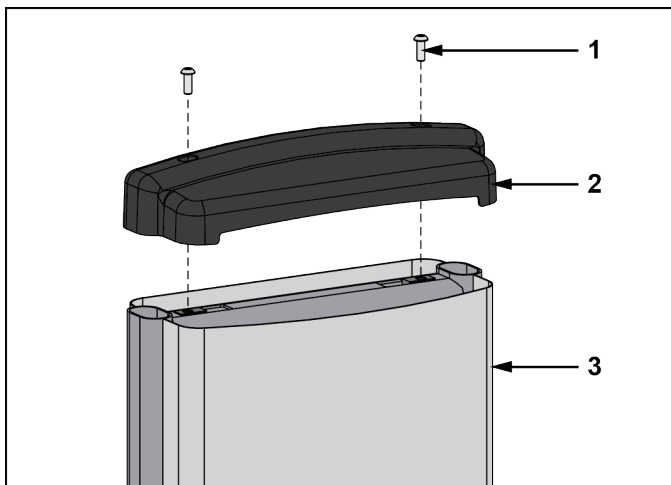

Item	Description	Qty.
1	BHSCS	2
2	Top cap	1
3	Back panel	1

5. Remove back panel from machine.
6. Verify weight stack pin is disengaged.

7. Remove spiral pin securing cable end to top weight using a 3/16" pin punch and hammer.

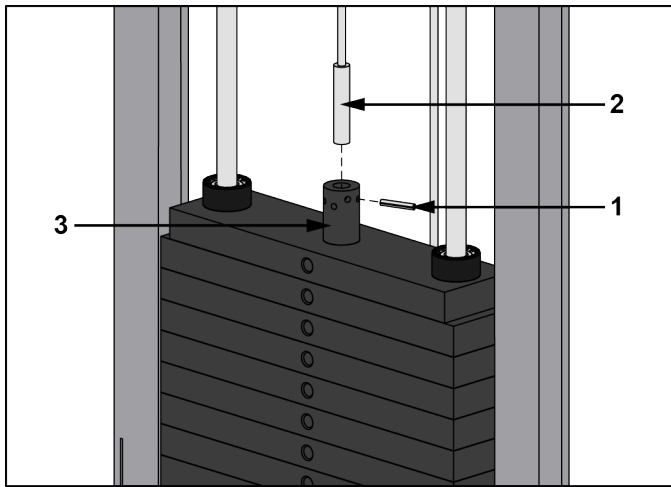

Item	Description	Qty.
1	Spiral pin	1
2	Cable	1
3	Top weight connector	1

8. Remove guide rod caps. Guide rod cap contains a compression spring that will fly if grasp is not released slowly. Slide spring loaded guide rod cap down guide rod until cap is clear of frame. Slowly release grasp of guide rod cap and remove.

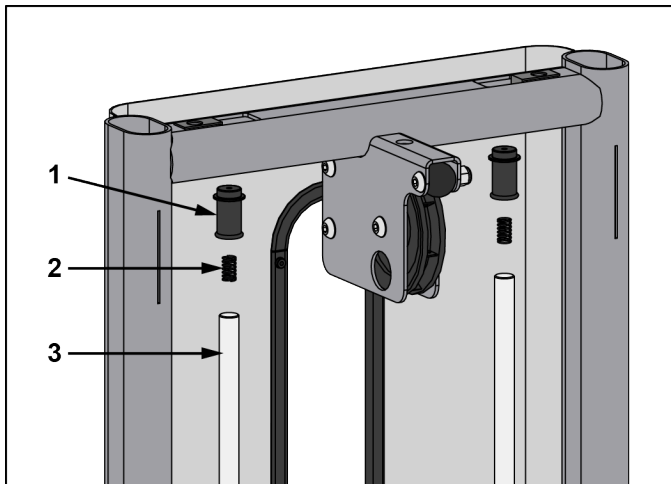

Item	Description	Qty.
1	Guide rod cap	2
2	Compression spring	2
3	Guide rod	2

9. Remove lifting post.

10. Remove weight plates.

11. Remove screws securing Chin-Up Bar to frame using a 7/32" Allen wrench and a 9/16" wrench.

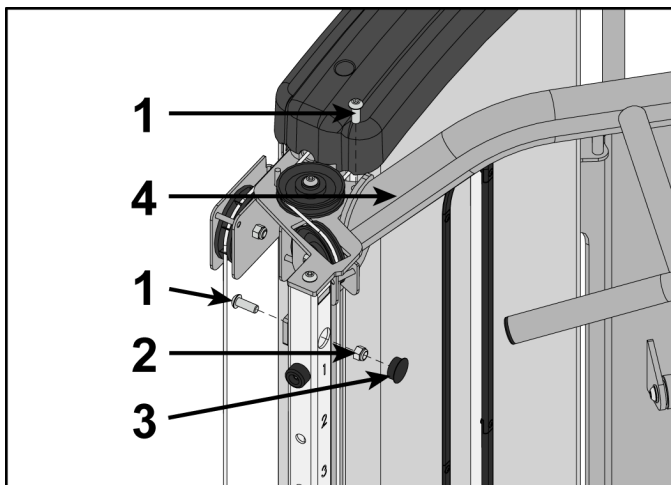

Item	Description	Qty
1	Screw	2
2	Locknut	1
3	Insert plug	1
4	Chin-Up Bar	1

12. Remove the four BHSCS securing one of the halves.

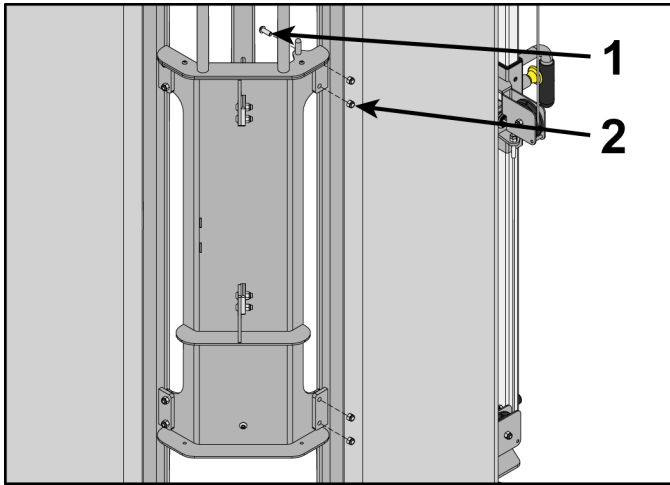

Item	Description	Qty
1	Screw	4
2	Locknut	4

13. Move machine to desired location.

14. Reattach the frame halves and securely tighten the four BHSCS.

15. Reattach Chin-Up Bar. Add Loctite #242 to each BHSCS and threaded holes. Tighten screws securely. Reattach insert plugs.

Install weight plates

1. Lean guide rods slightly outward, away from machine, DO NOT put excessive pressure on guide rods, it will damage lower guide rod caps.
2. Wipe the entire length of the guide rods with a clean cloth.
3. Lubricate the guide rods with a light coating of medium weight oil.
4. Install each weight plate, one at a time, so wide edge of bushing faces upward (1) and narrow edge of bushing (2) faces downward.

Correct: Wide bushing edge upward

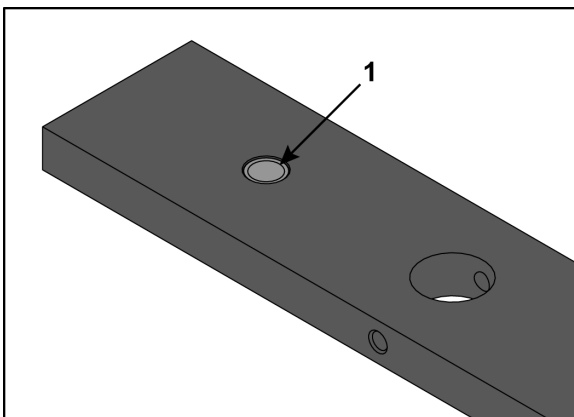

Incorrect: Narrow bushing edge downward.

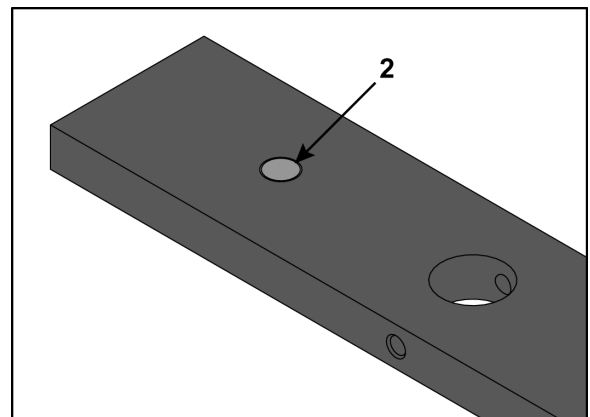

5. Install lifting post.

6. Install compression spring and top guide rod cap onto guide rod. Slide spring loaded top guide rod cap down guide rod until cap is clear of guide rod plate and install. Repeat for opposite side.

Apply weight plate decal

1. Peel off half of backing from weight plate decals, making sure that the decals remain attached to the front sheet.

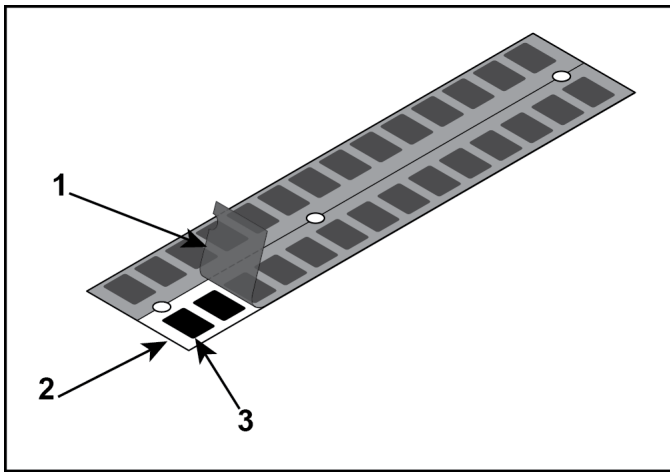

Item	Description	Qty
1	Backing	1
2	Front sheet	1
3	Weight decals	1

- Place decals front sheet in the correct position on weight plates.
- Insert a guide pin through each hole of the decals front sheet. A guide pin can be anything that fits through the weight stack hole, such as a weight stack selector pin.
- Align decals and rub them onto weight plates.
- Remove front sheet, do not peel decals off of weight plates.

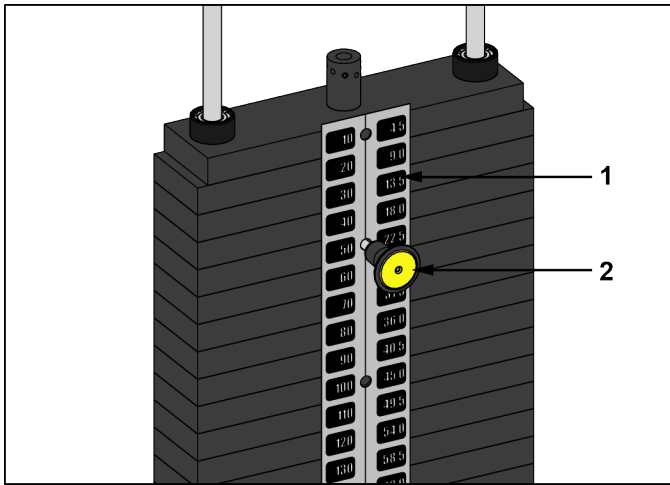

Item	Description	Qty
1	Weight plate decal	1
2	Weight stack selector pin	1

- Repeat above steps for other half of the weight plate decals.

Cable routing

1. Place a small amount of Loctite® on BHSCS and inside threads of ball stop.
2. Secure ball stop to cable using a 1/8" Allen wrench.
3. Reconnect handle, pulley, and cable to adjusting posts on both sides.
4. Position pulley mount parallel to the top weight.
5. Pull down on pulley mount until cable is tight.
6. Verify cable is still routed through all pulleys.
7. Attach pulley mount to lifting post with spiral pin using a hammer and 3/16" pin punch.

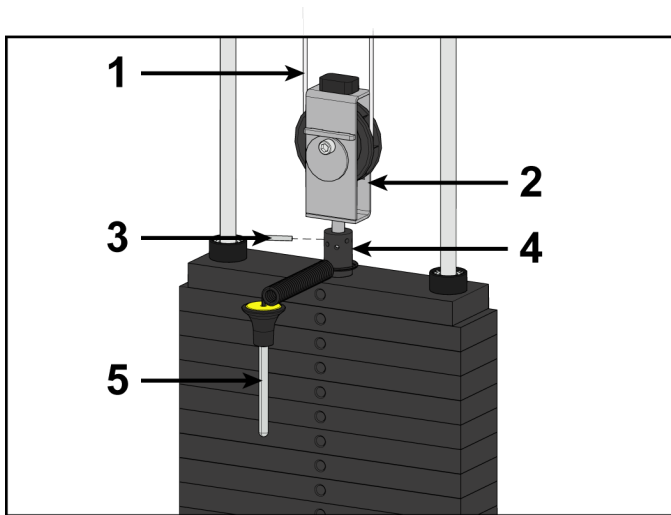

Item	Description	Qty
1	Cable	1
2	Pulley bracket	1
3	Roll pin	1
4	Top weight connector	1
5	Weight selector pin	1

8. Lift top weight up and down simulating normal operation (without selecting any resistance).
9. Verify the cable is moving smoothly.

Install back panel

1. Place back panel into position.
2. Secure top cap in place using two BHSCS and 7/32" Allen wrench.

Securely anchor machine to floor

Owner should not allow equipment to be used until it is properly anchored as described below.

- ⚠ WARNING:** Anchoring equipment:
- To maximize stability and eliminate rocking, tipping, or falling over, equipment must be anchored to a solid, level surface, utilizing all anchoring holes provided.
 - Fasteners must have a minimum of 500 lbs. tensile capacity. Cybex recommends .3/8" grade 2 bolts or better. A minimum pull force of 220 lbs/100 kgs is required for each anchor position.
 - If leg frames do not contact surface, DO NOT pull down with anchors. Shim any leg or frame not in contact with surface using flat washers.
 - Due to the wide variation of flooring on which machines may be anchored or installed, consult with a qualified and licensed contractor to ensure proper anchoring and installation.

Verify proper operation

Exercise

Intended Use

The intended commercial use of this machine is to aid exercise and improve general physical fitness.

Instructions

 **TIP:** Read and understand all instructions and warnings prior to using this machine in the Safety section of the Owner's Manual.

All adjustment points on the machine have yellow handles or knobs.

Set Up

1. Select appropriate resistance.
2. Adjust handles for proper pulley height.
3. Rotate pulleys to desired angle.
4. Adjust stabilization arm to desired angle.
5. Adjust stabilization pad to desired position.
6. Ensure all adjustment knobs are locked into place.
7. Position stabilization arm and pad all the way in and all the way down when finished.

 **CAUTION:** Use only in manner depicted. To avoid serious injury, use equipment only as describe in placards located on each machine.

Chest Press

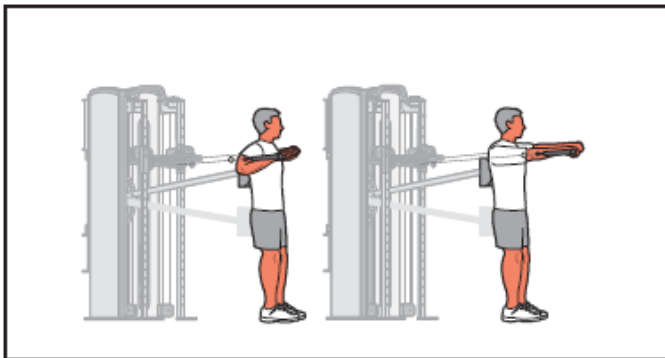

Row

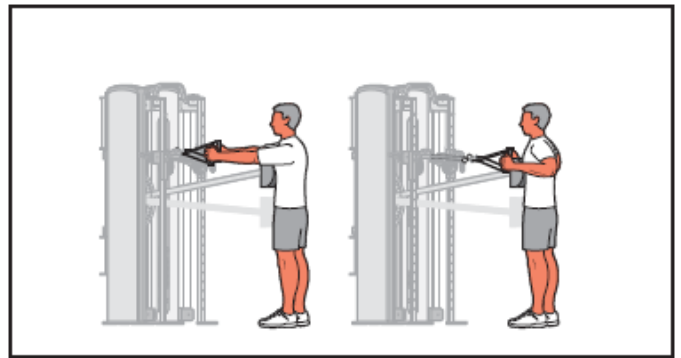

Seated Press

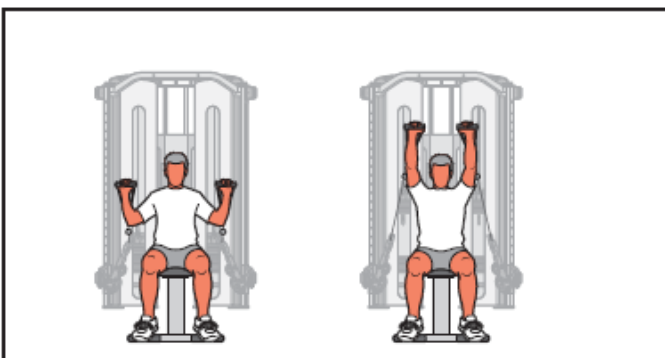

Arm Curl

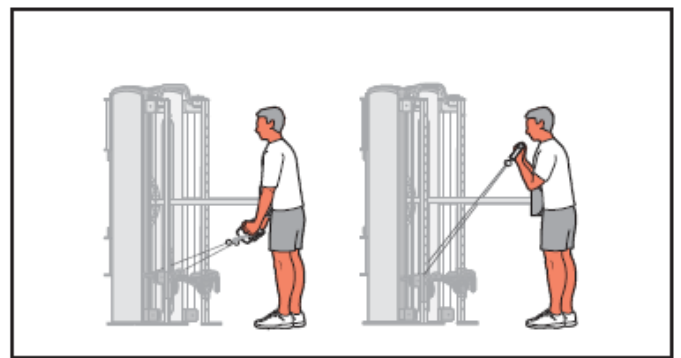

Arm Extension

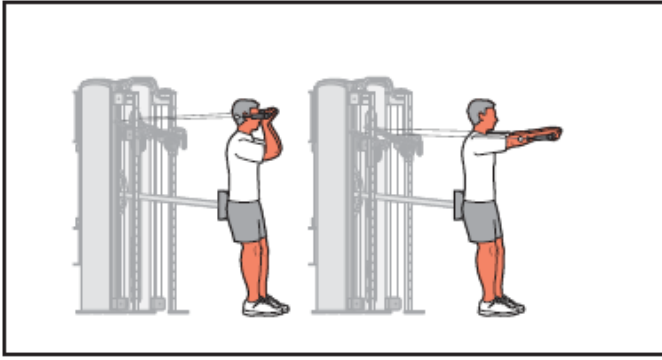

Trunk Rotation

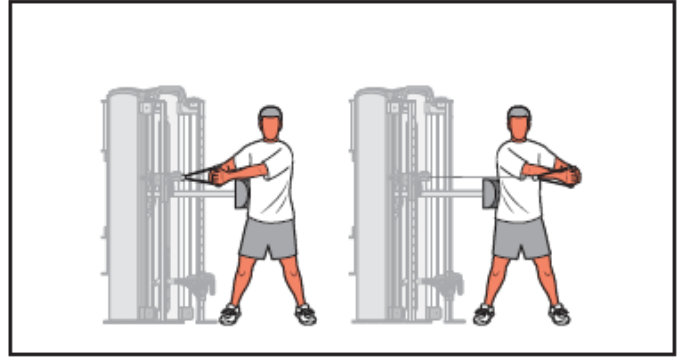

Squat

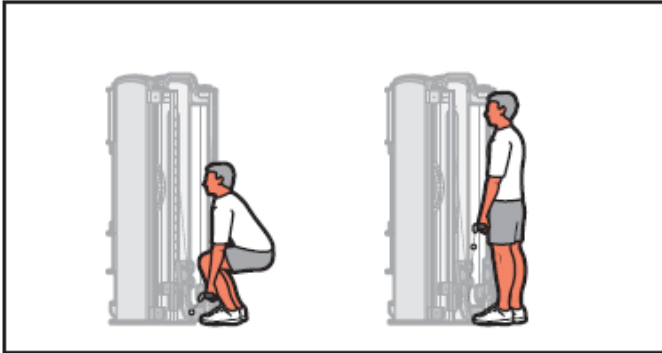

Hip Abduction

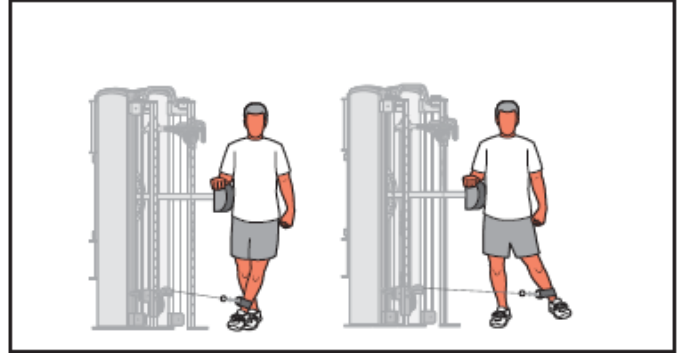

Hip Adduction

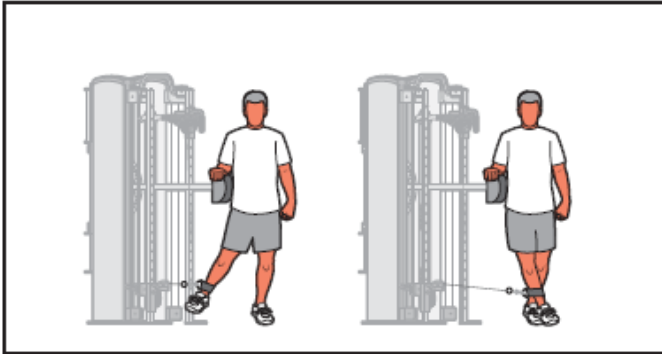

Hip Flexion

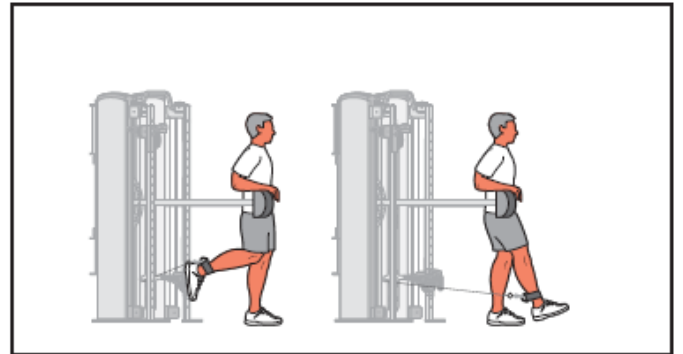

Hip Extension

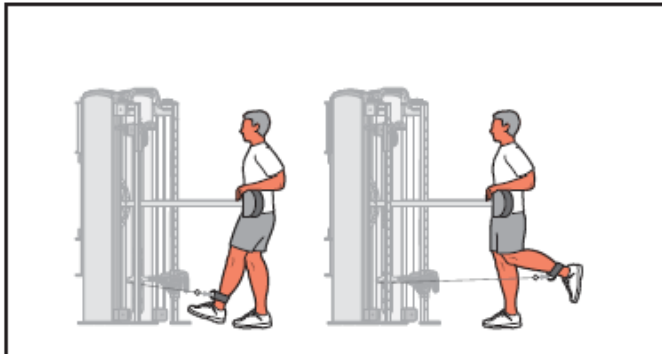

Trunk Flexion

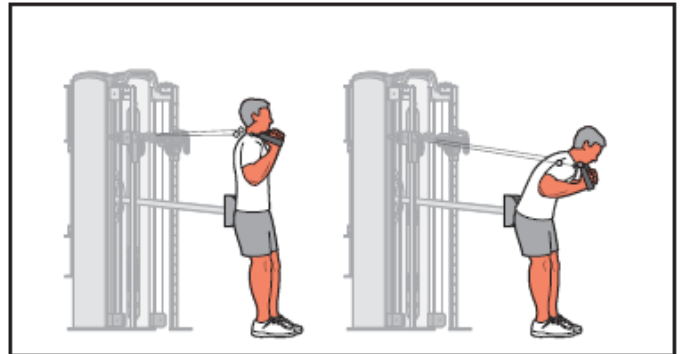

Trunk Extension

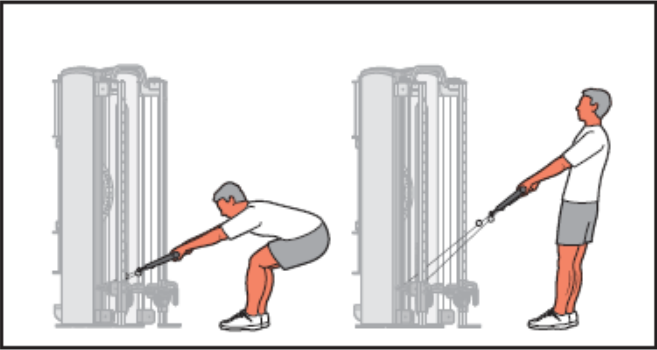



Maintenance

All preventive maintenance activities must be performed on a regular basis. Performing routine preventive maintenance actions can aid in providing safe, trouble-free operation of all Cybex equipment.

Cybex is not responsible for performing regular inspection and maintenance actions for your machines. Instruct all personnel in equipment inspection and maintenance actions and also in accident reporting and recording. Cybex representatives are available to answer any questions that you may have.

Warnings

 **TIP:** Read all warnings in this chapter.

-  **WARNING:** For maintenance, service and repair:
- Must be performed by trained service personnel only
 - Use only Cybex replacement parts.

 **WARNING:** Equipment hazard. To avoid serious injury or death replace worn or damaged components immediately and keep the equipment out of use until repair is completed.

 **WARNING:** The safety level of the equipment can be maintained only if the equipment is examined regularly for damage and wear.

Daily Procedures

When using strong cleaning agents such as rubbing alcohol or bleach, it is advisable to test first in an inconspicuous area. Other cleaning agents may contain harsh or unknown solvents and are subject to formula changes by the product manufacturer without notice. Should you desire to use other cleaning agents, carefully try them in an inconspicuous area to determine potential damage to the material. Never use harsh solvents or cleaners which are intended for industrial applications. To clean stained or soiled areas, a soft white cloth is recommended. Avoid use of paper towels.

Cleaning products may be harmful/irritating to your skin, eyes, etc. Use protective gloves and eye protection. **Do Not** inhale or swallow any cleaning product. Protect surrounding area/clothing from exposure. Use in well ventilated area. Follow all product manufacturer's warnings. Cybex and its vendors cannot be held responsible for damage or injuries resulting from the use or misuse of cleaning products.

Clean Upholstery

If	Then
Light Soiling	<ol style="list-style-type: none">1. Prepare a solution of 10% household liquid soap and warm water.2. Apply with a soft damp cloth.3. If necessary, apply a solution of liquid cleanser with a soft bristle brush.4. Dampen a clean soft cloth in water and wipe residue away.
More Difficult Stains	<ol style="list-style-type: none">1. Prepare a solution of 10% household bleach (sodium hypochlorite) and 90% water. Dampen a soft white cloth in the solution.2. Rub gently on the stained area.3. Dampen a clean soft cloth in water and rinse area.4. If stains are still present, a full strength household bleach may be used. Allow bleach to puddle on the affected area or apply with a bleached-soaked cloth for approximately 30 minutes. Dampen a clean soft cloth in water, and rinse area to remove any remaining bleach concentration.

If	Then
More Difficult Stains (Alternative Method)	<ol style="list-style-type: none"> 1. Dampen a soft white cloth with rubbing alcohol. 2. Gently rub stained area. 3. Dampen a clean soft cloth in water and rinse area.
Restoring Luster	<ol style="list-style-type: none"> 1. Apply a light coat of furniture wax for 30 seconds. 2. Lightly rub area using a clean white cloth.

Clean Frames

Wipe down all frames using a mild solution of warm water and car wash soap. Be sure to dry thoroughly. **AVOID** acid or chlorine based cleaners and also cleaners containing abrasives as these could scratch or damage the equipment.

Clean Chrome

Clean chrome tubes, first using chrome polish and then using a car wax seal. Neutral cleaners with a pH between 5.5 and 8.5 are recommended. Be sure to dry thoroughly. **AVOID** acid or chlorine based cleaners and also cleaners containing abrasives as these could scratch or damage the equipment.

Guidelines for cleaning front panel:

Use clean soft cloths or sponges for application of cleaners and again for washing and rinsing. Follow up each application with warm water rinse.

- **DO NOT** use abrasives or high alkaline cleaners.
- **DO NOT** leave cleaners on for long periods, wash immediately.
- **DO NOT** apply cleaners in direct sunlight or at elevated temperatures.
- **DO NOT** use scrapers, squeegees, or razors.
- **DO NOT** clean with gasoline.

Compatible Cleaners and Detergents:

- Formula 409
- Top Job
- Joy
- Palmolive
- Windex with Ammonia D

To Minimize Fine or Hairline Scratches:

Mild automotive polish applied and removed with a soft clean cloth will help fill scratches.

Suggested Polishes:

- Johnson Paste Wax
- Mirror Glaze #10 Plastic Polish (by Mirror Bright Polish Co.)
- Novus Plastics Polish #1, #2 (By Novus Inc.)

Weekly Procedures

Inspect All Nuts and Bolts

Tighten all loose nuts and bolts as required.





WARNING: Equipment hazard. To avoid serious injury or death replace worn or damaged components immediately and keep the equipment out of use until repair is completed.

Inspect Cables

Inspect all cables for wear or damage and proper tension. When inspecting cables, run fingers on the cable, paying particular attention to bends and attachment points.

The following conditions may indicate a worn cable:

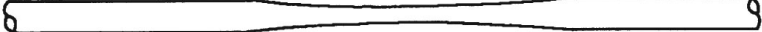
Condition of Cable	Diagram
A tear or crack in the cable sheath that exposes the cable	
A kink in the cable	
A curled sheath	
Necking - A stretched cable sheath	

Bars and Handles

Inspect bars and handles for wear, paying particular attention to tab area connection points.

- ⚠ CAUTION:** Worn handles
- Do not use handles if less than 1/8" of material remains on edge.
 - Replace all worn handles immediately.

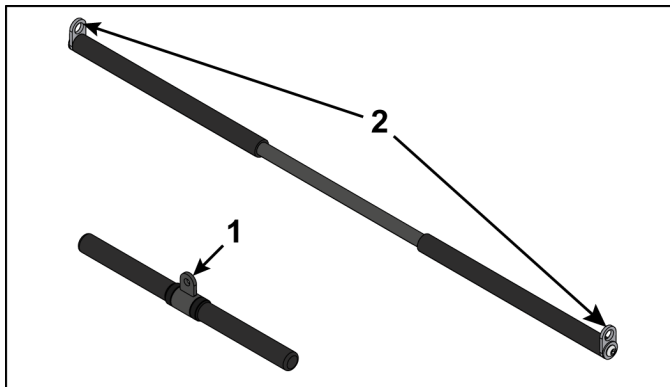

Item	Description	Qty
1	Attachment hole (Straight handle)	1
2	Attachment hole (Lat bar)	2

Inspection	Action
Inspect bars and handles for wear, paying particular attention to tab area connection points.	Replace all worn handles immediately.
Inspect snap links for proper latching (indicates wear).	Replace all worn snap links immediately.

Inspect Other Items

Inspect other items for proper operation, damage, or wear.

Inspection	Action
Inspect grips for looseness or wear.	Replace all loose or worn grips immediately.
Inspect all labeling for readability, including instructional placards, warning and caution decals.	Replace all worn labeling immediately.
Inspect all weight stacks for proper alignment and operation.	Correct all improper alignment and operation issues immediately.
Inspect guide rods for lubrication.	Wipe Weight Stack Guide Rods clean over entire length. Lubricate with a light coat of medium weight automotive engine oil.

Yearly Procedures

Replace all cables and belts annually

Cable Adjustment

Tools Required

- 9/16" Wrench (2)
- Hammer
- 3/16" Pin punch

Four types of cable tension adjustment are used on Cybex Strength Systems:

Jam Nut Adjustment

This type of adjustment uses a jam nut and a tension adjustment nut at the cable cam end as the primary adjustment. The other end of the cable usually contains a roll pin adjustment.

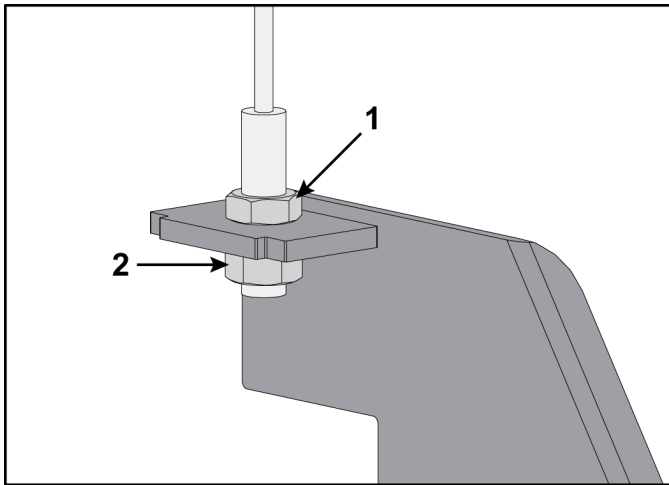

Item	Description	Qty.
1	Jam nut	1
2	Tension adjustment nut	1

Rod End Adjustment

This type of adjustment uses a socket head cap screw (SHCS) securing a cable rod end bearing to the machine. Primary adjustment is by turning the rod end bearing. The other end of the cable usually contains a roll pin cable adjustment.

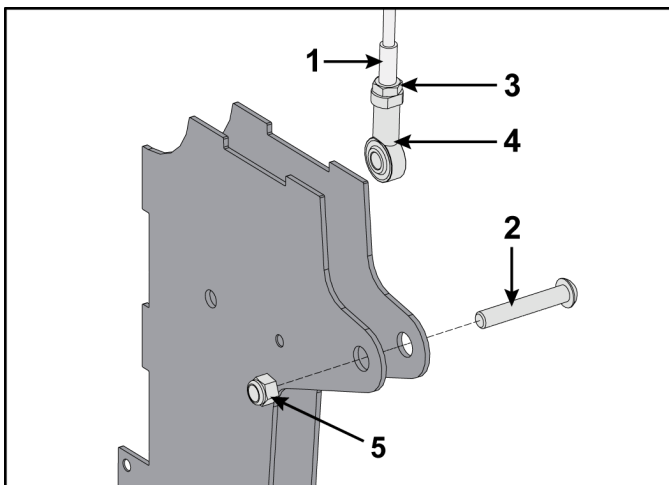

Item	Description	Qty.
1	Cable end	1
2	SHCS	1
3	Jam nut	1
4	Cable rod end bearing	1
5	Nylon locknut	1

Roll Pin Adjustment

This type of adjustment uses a roll pin and series of holes in the weight stack top weight connector.

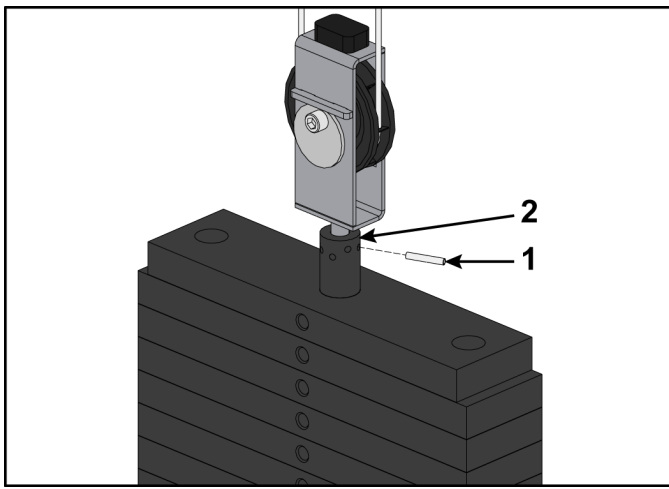

Item	Description	Qty.
1	Roll pin	1
2	Top weight connector	1

Cam End Adjustment

This type of adjustment uses an adjustment bolt on the pulley bracket. Loosen nut and rotate cam bolt to adjust cable.

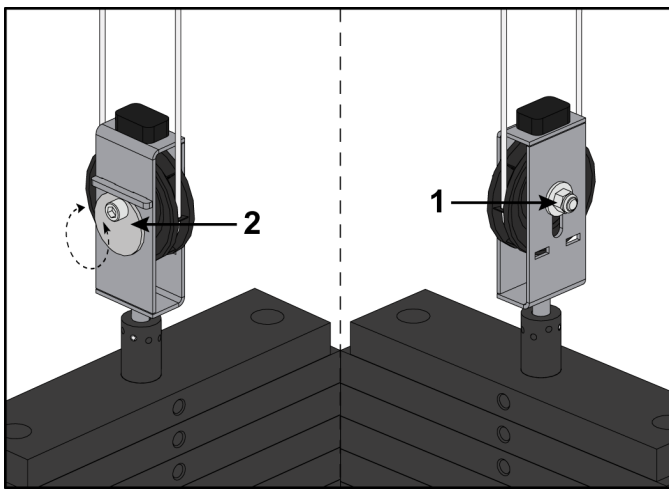

Item	Description	Qty.
1	Nut	1
2	Cam bolt adjustment	1

Warranty

What is Covered

This CYBEX commercial exercise equipment product is warranted to be free of all defects in material and workmanship.

Who is Covered

The original purchaser or any person receiving the product as a gift from the original purchaser.

Who Pays Transportation and Insurance For Service

If the Product or any covered part must be returned to a service facility for repairs, We, Cybex, will pay all transportation and insurance charges for the first year. You are responsible for transportation and insurance charge after the first year.

What We Will Do To Correct Covered Defects

We will ship to you any new or rebuilt replacement part or component, or at our option, replace the Product. Such replacement parts are warranted for the remaining portion of the original warranty period.

What is Not Covered

Any failures or damage caused by unauthorized service, misuse, accident, negligence, improper assembly or installation, debris resulting from any construction activities in the Product's environment, rust or corrosion as a result of the Product's location, alterations or modifications without our written authorization, or by failure on your part to use, operate and maintain the Product as set out in your Operation Manual.

All terms of this warranty are void if this product is moved beyond the continental borders of the United States of America (excluding Alaska, Hawaii and Canada) and are then subject to the terms provided by that country's local authorized Cybex representative.

Owner's Manual

It is VERY IMPORTANT THAT YOU READ THIS MANUAL before operating the Product. Remember to perform the periodic maintenance requirements specified in the Manual to assure proper operation and your continued satisfaction.

Exclusive Warranty

THIS LIMITED WARRANTY IS IN LIEU OF ALL OTHER WARRANTIES OF ANY KIND EITHER EXPRESSED OR IMPLIED, INCLUDING BUT NOT LIMITED TO THE IMPLIED WARRANTIES OF MERCHANTABILITY AND FITNESS FOR A PARTICULAR PURPOSE, AND ALL OTHER OBLIGATIONS OR LIABILITIES ON OUR PART. We neither assume nor authorize any person to assure for us any other obligation or liability concerning the sale of this Product. Under no circumstances shall we be liable under this warranty, or otherwise, of any damage to any person or property, including any lost profits or lost savings, for any special, indirect, secondary, incidental or consequential damages of any nature arising out of the use of or inability to use this Product. Some states do not allow the exclusion or limitation of implied warranties or of liability for incidental or consequential damages, so the above limitations or exclusions may not apply to you. Warranty coverages and terms may differ outside the United States. Please contact the Cybex office servicing your country (contact information found at the front of this manual) or visit the applicable local Cybex website to receive the specific warranty information for your country.

Changes in Warranty Not Authorized

No one is authorized to change, modify or extend the terms of this limited warranty.

Effects of State Laws

This warranty gives you specific legal rights, and you may have other rights which vary from state to state and country by country.

Warranty Coverage

 **NOTE:** There is no warranty coverage for labor on Strength Products.

Item	10 Years	5 Years	1 Year	90 Days
Frame	X			
Pillow Blocks		X		
Pulleys		X		
Weight Plates		X		
Guide Rods		X		
Cables			X	
Grips			X	
Bearings			X	
Belts / Springs				X
Upholstery				X
Hardware / Mechanical				X
Items Not Specified				X



Columbia Center III - 9525 West Bryn Mawr Ave, Rosemont, IL 60018 • 800-351-3737 • 847-288-3700 • FAX 800-216-8893

www.cybexintl.com