



Eagle® NX Glute
Owner's Manual
Strength Systems
Part Number 20170-999-4 A

Table of Contents

Safety

Safety Guidelines and Practices.....	3
Anchoring Equipment.....	3
Facility Safety Precautions.....	3
User Safety Precautions.....	4
Warnings and Cautions.....	5
Label Placement.....	5

Assembly

Machine Specifications.....	7
Verify parts list below.....	7
Choosing and Preparing a Site.....	8
Tools Required.....	8
Assembly Procedure.....	8

Exercise

Intended Use.....	17
Instructions.....	17

Maintenance

Warnings.....	18
Daily Procedures.....	18
Weekly Procedures.....	20
Yearly Procedures.....	21
Cable Adjustment.....	22

Customer Service

Product Registration.....	25
Contacting Service.....	25
Ordering Parts.....	25
Return Material Authorization (RMA).....	26
Damaged Parts.....	26

Cybox® and the Cybox logo are registered trademarks of Cybox International, Inc. Eagle® and its mark are registered trademarks of Cybox International, Inc.

DISCLAIMER: Cybox International, Inc. makes no representations or warranties regarding the contents of this manual. We reserve the right to revise this document at any time or to make changes to the product described within it without notice or obligation to notify any person of such revisions or changes.

© Copyright 2015, Cybox International, Inc.

10 Trotter Drive, Medway, MA 02053 • 888-462-9239 • 508-533-4300 • FAX 508-533-5183

www.cyboxintl.com • 20170-999-4 A • June 2015

Safety

Safety Guidelines and Practices

 Read the Owner's Manual carefully before assembling, servicing, or using the equipment. Owner must comply with all safety guidelines in this manual. It is also the owner's responsibility to instruct users on the safe and proper operation of the equipment and to properly display any and all warning labels and instructional placards. All users should read these labels and placards before using equipment.

⚠ WARNING

Serious injury or death could occur if the following safety precautions and instructions are not followed.

Anchoring Equipment

Owner should not allow equipment to be used until it is properly anchored as described below.

⚠ WARNING

Anchoring equipment:

- To maximize stability and eliminate rocking, tipping, or falling over, equipment must be anchored to a solid, level surface, utilizing all anchoring holes provided.
- Fasteners must have a minimum of 500 lbs. tensile capacity. Cybex recommends $.3/8$ " grade 2 bolts or better. A minimum pull force of 220 lbs/100 kgs is required for each anchor position.
- If leg frames do not contact surface, DO NOT pull down with anchors. Shim any leg or frame not in contact with surface using flat washers.
- Due to the wide variation of flooring on which machines may be anchored or installed, consult with a qualified and licensed contractor to ensure proper anchoring and installation.

Facility Safety Precautions

Do not allow anyone, including trainers, to use equipment in a manner other than that shown on the warning labels and instructional placards located on every machine.

Do not install equipment on an uneven surface. The solid, level surface should not deviate more than $1/8$ " over a 10' distance or as defined and required by local building and architectural codes.

It is the responsibility of the facility owner/owner of the equipment to ensure that there is appropriate clearance around each machine to allow for safe use and passage.

In compliance with the ADA (American Disabilities Act) there must be clear floor space of at least 30 by 48 inches and be served by an accessible route for at least one of each type of exercise equipment. If the clear space is enclosed on three sides (e.g., by walls or the equipment itself), the clear space must be 36 by 48 inches.

All other machines must have a clear floor space of 23” for all access point on the machine, unless shown in the Owner’s Manual.

The dimensions stated in the assembly instructions of this manual include the maximum foot print (in use) dimensions.

All equipment should be used in a supervised, access-controlled area.

Do not allow equipment to be used by children 12 and under. Supervise disabled and children 13 and older.

The owner should ensure that regular inspection and maintenance checks as detailed in this manual are performed. Keep a log of all maintenance and repair activities.

Each day before use, the owner should inspect the equipment. If there are any loose or worn components such as belts, cables, grips, pulleys, or any missing, damaged labels, or placards, the owner should fix any deficiencies before they allow the equipment to be used.

Use only Cybex components to maintain and repair the equipment.

Display the Facility Safety Sign so it is visible and prominent.

User Safety Precautions

Owners must instruct users to DO the following:

- Follow all warning labels and instructional placards when using equipment.
- Insert weight pin completely before using selectorized equipment.
- Consult a physician prior to commencing an exercise program. If at any time during exercise you feel faint, dizzy or experience pain, stop and consult your physician.
- Use a spotter for Free Weight equipment.

Owners must instruct users to NOT DO the following:

- **DO NOT** pin weights on selectorized equipment in an elevated position or use the machine if found in this position
- **DO NOT** increase weight resistance on equipment by any means other than those provided by Cybex.
- **DO NOT** wear loose or dangling clothing or jewelry while using equipment. Stay clear of moving parts.
- **DO NOT** lean or pull on machine
- **DO NOT** use machine for support during stretching.
- **DO NOT** attach resistance straps, ropes or other means to equipment, except those provided by the manufacturer for intended use on the equipment.
- **DO NOT** exceed the maximum specified user weight.
- **DO NOT** use if equipment appears damaged or inoperable upon inspection
- **DO NOT** use if guards are missing or damaged.
- **DO NOT** remove any labeling from equipment.

Warnings and Cautions

Warning labels indicate a potentially hazardous situation that could result in serious injury or death if the precautions are not observed.

Caution labels indicate a potentially hazardous situation that could result in serious injury or damage to machine if the precautions are not observed.

See Contacting Service to replace any worn or damaged labels.



Label Placement

The following diagram shows where each label is located.

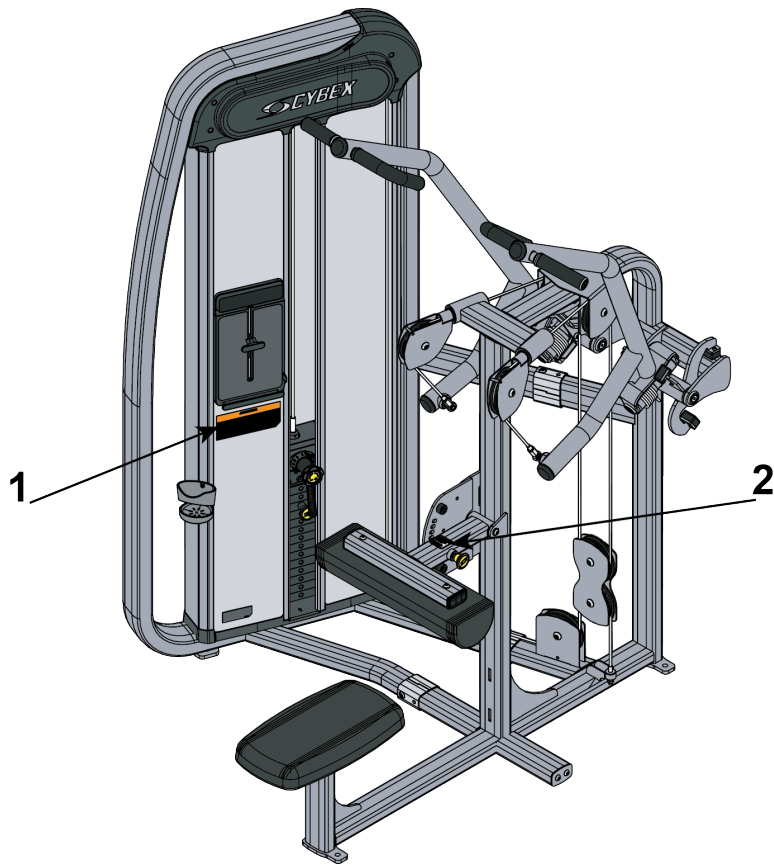

	Description	Qty
1	DE000023-X	1
2	8500-025-X	1

Assembly

Machine Specifications

Total Weight and Size 20130 Pull Down

Weight	Machine Dimensions at Rest	Machine Dimensions in Use
635 Lbs	57" L × 65" W × 74" H	Same
288 Kg	145" cm L × 165 cm W × 188 cm H	Same

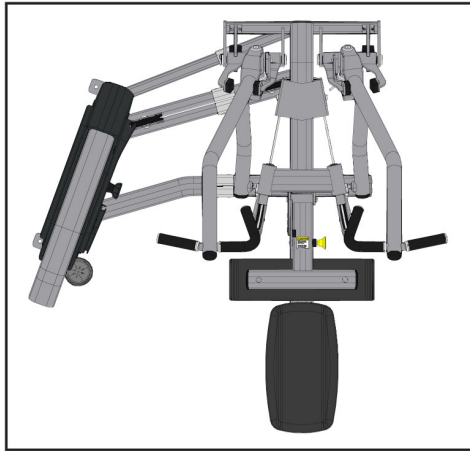

Maximum User Weight	Maximum Training Weight
300 lbs/135 kg	305 lbs/138 kg

Verify parts list below

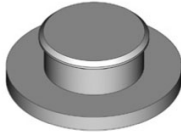
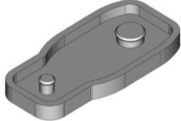
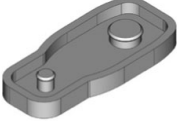
Qty	Part Number	Description	Diagram
3	20000-339	Foot Pad	
2	20000-376	Foot Pad	
3	20000-377	Foot Pad	

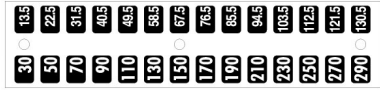
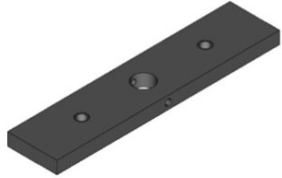
Qty	Part Number	Description	Diagram
1	12000-560	Decal, Weight Plate (30-290)	
13	4000C101	Weight Stack Plate	

Choosing and Preparing a Site

Before assembling the unit, verify the chosen site meets the following criteria:

- Area is well lit and well ventilated.
- Surface is structurally sound and properly leveled.
- Free area for access to unit and emergency dismount. Minimum clearance is 23.6 inches (0.6 meters).
- Adjacent units may share the free area.

It is the responsibility of the facility owner/owner of the equipment to ensure that there is appropriate clearance around each machine to allow for safe use and passage.

In compliance with the ADA (American Disabilities Act) there must be clear floor space of at least 30 by 48 inches and be served by an accessible route for at least one of each type of exercise equipment. If the clear space is enclosed on three sides (e.g., by walls or the equipment itself), the clear space must be 36 by 48 inches.

All other machines must have a clear floor space of 23" for all access point on the machine, unless shown in the Owner's Manual.

Tools Required

- 7/32" Allen wrench
- 5/16" Allen wrench (2)
- 3/4" Socket wrench
- Hammer
- 3/16" Pin punch
- Phillips screwdriver
- Loctite® #242
- Medium weight automotive engine oil
- Clean Cloth

Assembly Procedure

Two people will be required for this procedure.

-  Read and understand all instructions thoroughly before assembling this unit. Check all items carefully. If there is damage, see the Customer Service section of this manual for proper procedure to return, replace, or reorder parts.

If machine CAN fit through doorway

Two people will be required for this procedure

1. Move to desired location.
2. Remove shipping cones using a 3/4" socket or wrench.
3. Remove bolt from shipping cone with hammer. Recycle cone. ♻️
4. Attach foot pads to each foot of frame.
5. If weight stack needs to be installed, follow procedure for installing weight plates and weight plate decal.

If machine CANNOT fit through doorway

Two people will be required for this procedure

1. Remove shipping cones using a 3/4" socket or wrench.
2. Remove bolt from shipping cone with hammer. Recycle cone. ♻️

Disconnect cable

1. Make a note of the current cable routings and connections. This will assist you in reinstalling them properly.
2. Remove ten screws securing top covers (front and back) to frame using a Phillips screwdriver.

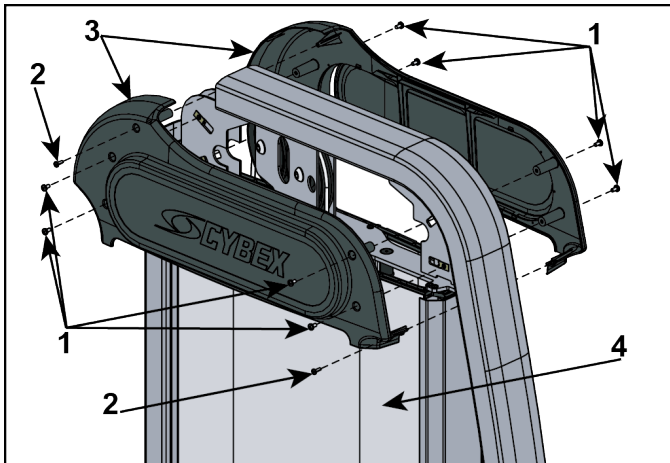

	Description	Qty
1	10-32 screw	8
2	# 8 screw	2
3	Top cover	2
4	Back panel	1

3. Guide front top cover down cable to gain access to pulley assembly.
4. Slide back panel upward and remove.

- Squeeze sides of top weight cover together and lift up.

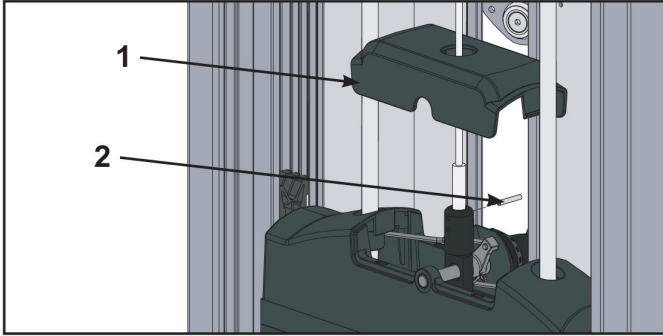

	Description	Qty
1	Top weight cover	1
2	Spiral pin	1

- Remove spiral pin connecting cable assembly using a hammer and a 3/16" pin punch.

Remove pulley assembly

- Remove two button head socket cap screws (BHSCS) and two pulley shaft bolts securing top two pulley assemblies to pulley bracket using two 5/16" Allen wrenches.

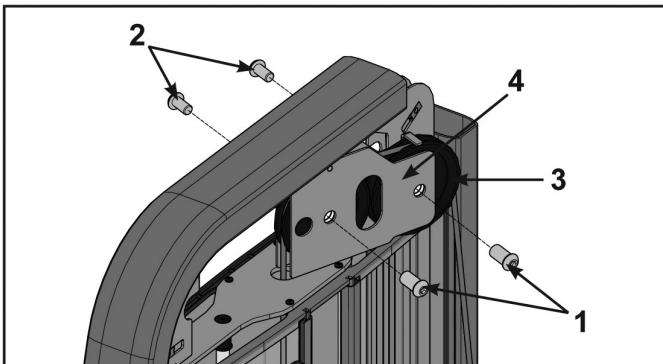

	Description	Qty
1	Pulley shaft bolt	2
2	BHSCS	2
3	Pulley assembly	2
4	Pulley bracket	1

- Remove pulley assemblies from pulley bracket.
- Remove BHSCS and pulley shaft bolts securing lower pulley assembly to pulley bracket using two 5/16" Allen wrenches.

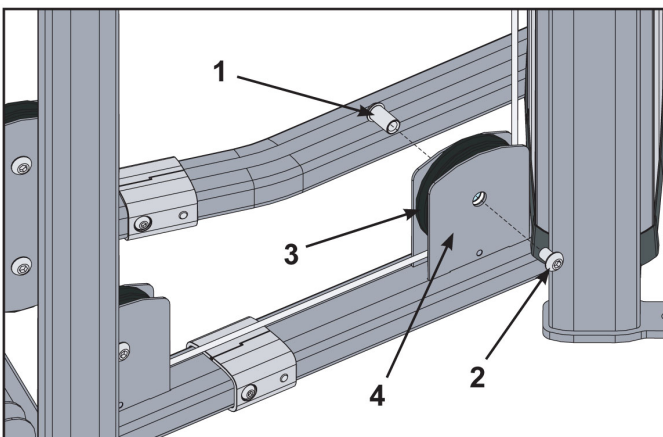

	Description	Qty
1	Pulley shaft bolt	1
2	BHSCS	1
3	Lower pulley assembly	1
4	Pulley bracket	1

- Remove pulley assembly from pulley bracket.
- Route cable up through top cover, guide rod plate, and pulley bracket.

- Set cable aside for rerouting.

Remove weight plates

- Turn the increment weight adjusting knob to select 0 lbs (0 kg).
- Remove four Phillips head screws and plastic mount for guide rod access.

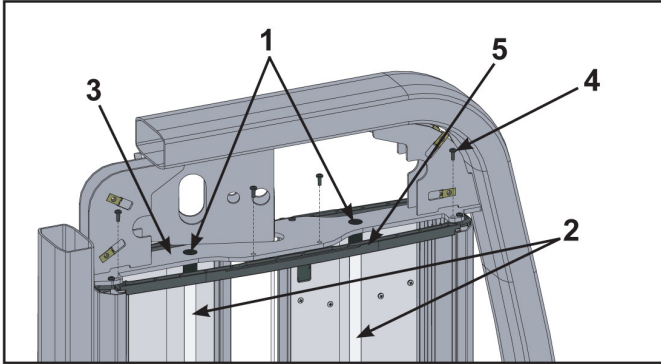

	Description	Qty
1	Top guide rod cap	2
2	Guide rod	2
3	Guide rod plate	1
4	Phillips head screw	4
5	Plastic mount	1

- Remove top guide rod caps. Top guide rod cap contains a compression spring that will fly if grasp is not released slowly. Slide spring loaded top guide rod cap down guide rod until cap is clear of frame. Slowly release grasp of top guide rod cap and set aside.
- Repeat above step for opposite guide rod.
- Lean guide rods slightly outward, away from machine. DO NOT put excessive pressure on guide rods, it will damage lower guide rod caps.
- Slide top weight up and out of the machine and set aside.
- Remove weight plates and set aside for re-installation later.

Separate Frame

- Remove six bolts and three connectors securing two halves of the frame using a 7/32" Allen wrench.

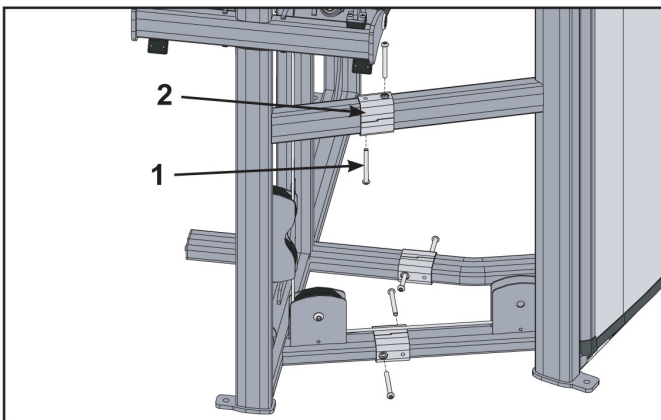

	Description	Qty
1	Bolt	6
2	Connector	3

- Move each half through the doorway to the desired location.

Assemble Frame

1. Apply #242 Loctite to bolts.

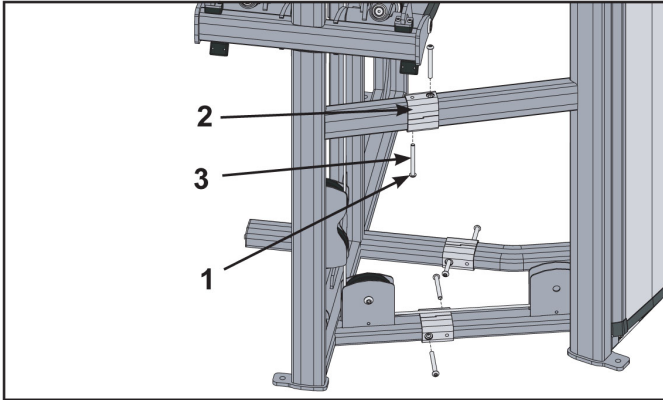

	Description	Qty
1	Bolt	6
2	Connector	3
3	# 242 Loctite	1

2. Secure two halves of the frame with the six bolts and three connectors, using a 7/32" Allen wrench.

Install weight plates

1. Lean guide rods slightly outward, away from machine, DO NOT put excessive pressure on guide rods, it will damage lower guide rod caps.
2. Wipe the entire length of the guide rods with a clean cloth.
3. Lubricate the guide rods with a light coating of medium weight oil.
4. Install each weight plate, one at a time, so wide edge of bushing faces upward (1) and narrow edge of bushing (2) faces downward.

Correct: Wide bushing edge upward

Incorrect: Narrow bushing edge downward.

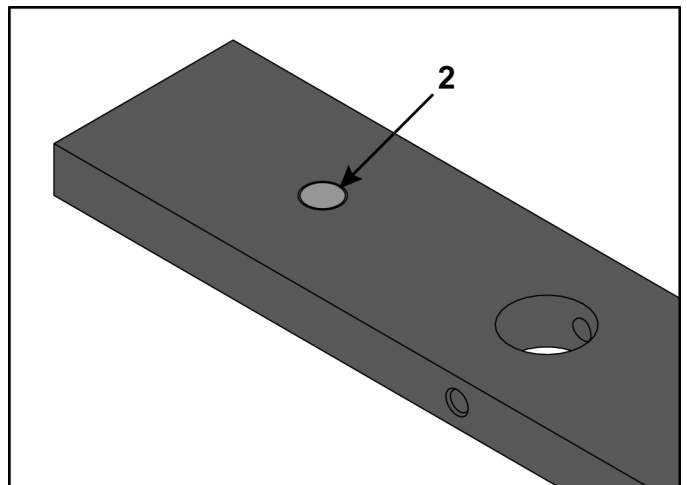
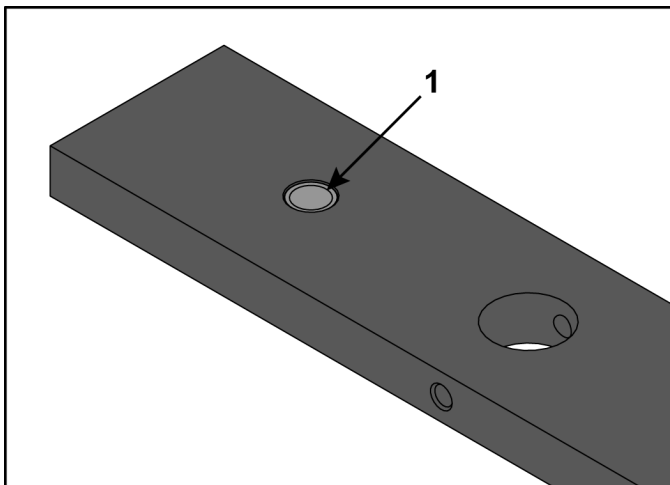

5. Slide top weight onto guide rods.

- Install compression spring and top guide rod cap onto guide rod. Slide spring loaded top guide rod cap down guide rod until cap is clear of guide rod plate and install. Repeat for opposite side.

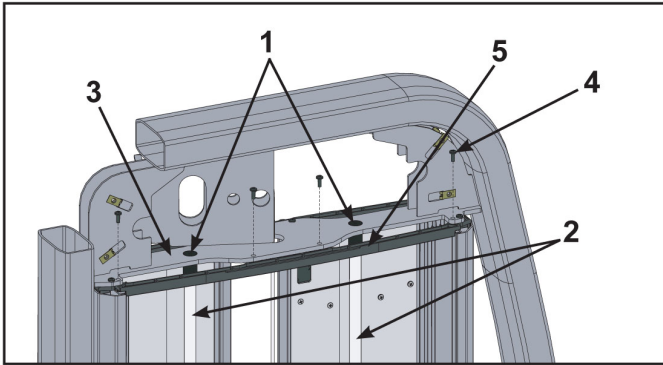

	Description	Qty
1	Top guide rod cap	2
2	Guide rod	2
3	Guide rod plate	1
4	Phillips head screw	4
5	Plastic mount	1

- Install four Phillips head screws securing plastic mount to guide rod plate.

Apply weight plate decal (if not already installed on weight plates)

- Peel off half of backing from weight plate decals, making sure that the decals remain attached to the front sheet.

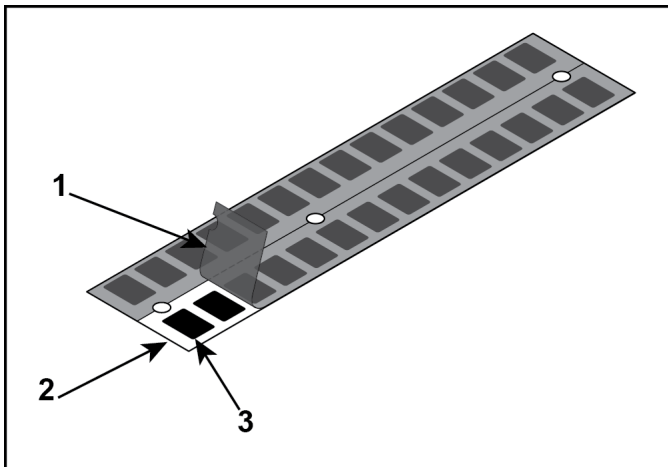

	Description	Qty
1	Backing	1
2	Front sheet	1
3	Weight decals	1

- Place decals front sheet in the correct position on weight plates.
- Insert a guide pin through each hole of the decals front sheet. (A guide pin can be anything that fits through the weight stack hole, such as a weight stack selector pin.)
- Align decals and rub them onto weight plates.

- Remove front sheet, do not peel decals off of weight plates.

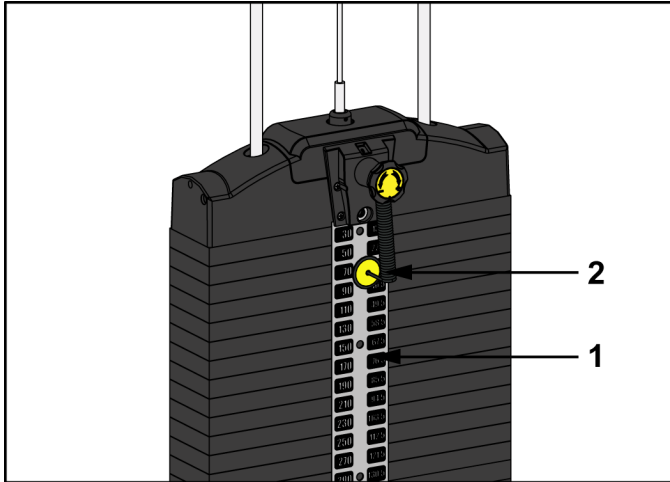

	Description	Qty
1	Weight stack selector pin	1
2	Weight plate decals	1

- Repeat above steps for other half of the weight plate decals.

Install cable

- Route cable through slot in top cover, through pulley bracket, and down through guide rod plate.
- Install two BHSCS and two pulley shaft bolts securing lower pulley assembly to pulley bracket using two 5/16" Allen wrenches.

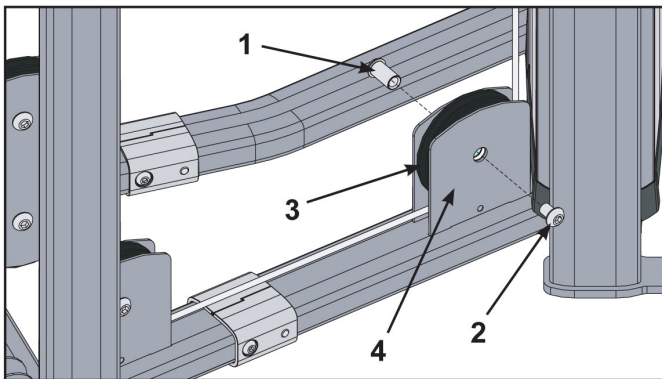

	Description	Qty
1	Pulley shaft bolt	1
2	BHSCS	1
3	Lower pulley assembly	1
4	Pulley bracket	1

- Install two BHSCS and two pulley shaft bolts securing top two pulley assemblies to pulley bracket using two 5/16" Allen wrenches.

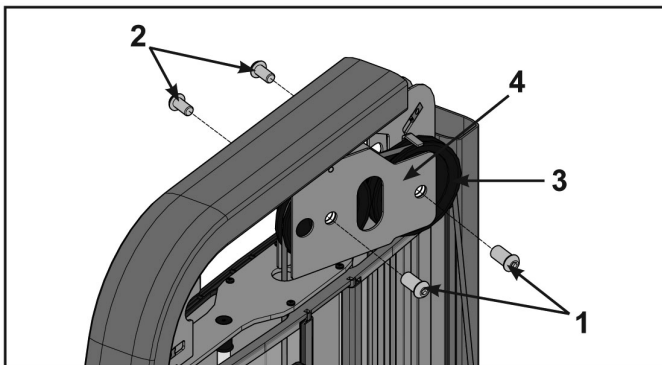

	Description	Qty
1	Pulley shaft bolt	2
2	BHSCS	2
3	Top pulley assembly	2
4	Pulley bracket	1

- Squeeze sides of top weight cover together and lift up. Pull down on cable until it is tight. Install spiral pin connecting cable assembly to top weight.

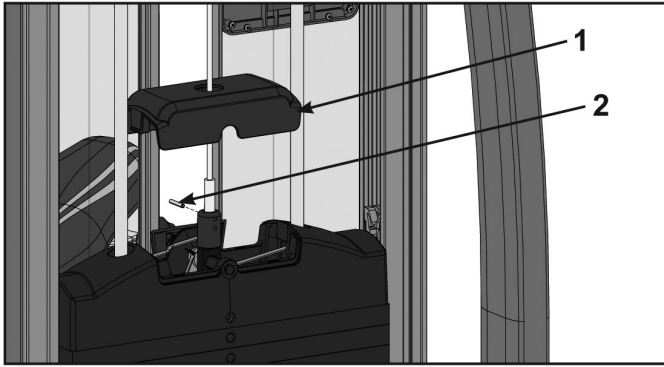

	Description	Qty
1	Top weight cover	1
2	Spiral pin	1

- Verify the cable is moving smoothly.
- Install back panel.
- Install ten screws securing top covers (front and back) to frame using a Phillips screwdriver.

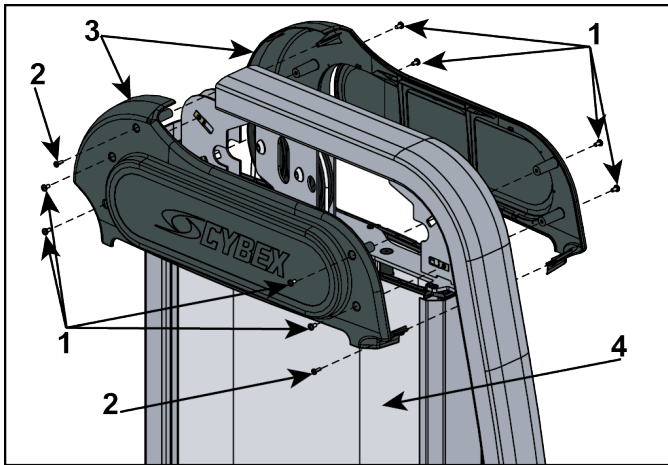

	Description	Qty
1	10-32 screw	8
2	# 8 screw	2
3	Top cover	2
4	Back panel	1

Securely anchor machine to floor

Owner should not allow equipment to be used until it is properly anchored as described below.

⚠ WARNING

Anchoring equipment:

- To maximize stability and eliminate rocking, tipping, or falling over, equipment must be anchored to a solid, level surface, utilizing all anchoring holes provided.
- Fasteners must have a minimum of 500 lbs. tensile capacity. Cybex recommends .3/8" grade 2 bolts or better. A minimum pull force of 220 lbs/100 kgs is required for each anchor position.
- If leg frames do not contact surface, DO NOT pull down with anchors. Shim any leg or frame not in contact with surface using flat washers.
- Due to the wide variation of flooring on which machines may be anchored or installed, consult with a qualified and licensed contractor to ensure proper anchoring and installation.

Verify proper operation

Exercise

Intended Use

The intended commercial use of this machine is to aid exercise and improve general physical fitness.



Instructions

 Read and understand all instructions and warnings prior to using this machine in the Safety section of the Owner's Manual.

CAUTION

Use only in manner depicted. To avoid serious injury, use equipment only as describe in placards located on each machine.

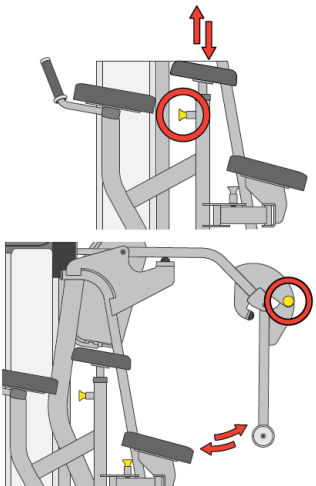
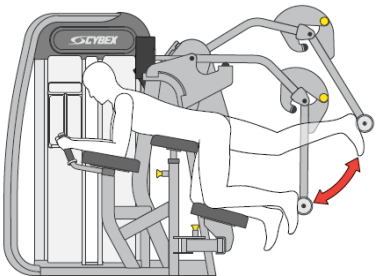
All adjustment points on the machine have yellow handles or knobs.

Set Up	Motion	Muscles Used
<ul style="list-style-type: none"> Adjust abdominal pad for comfortable support. Adjust foot bar to decided start position. Rest lower leg and forearms on pad and grasp handles. Place foot of opposite leg against foot bar. 	<ul style="list-style-type: none"> Push to the rear and upward while maintaining body position. To repeat for opposite side, adjust knee pad and switch sides. 	<p>Gluteus Maximus, Hamstrings, Quadriceps, Adductors</p>
		

Maintenance

All preventive maintenance activities must be performed on a regular basis. Performing routine preventive maintenance actions can aid in providing safe, trouble-free operation of all Cybex equipment.

Cybex is not responsible for performing regular inspection and maintenance actions for your machines. Instruct all personnel in equipment inspection and maintenance actions and also in accident reporting and recording. Cybex representatives are available to answer any questions that you may have.

Warnings

 Read all warnings in this chapter.

⚠ WARNING

For maintenance, service and repair:

- Must be performed by trained service personnel only
- Use only Cybex replacement parts.

⚠ WARNING

Equipment hazard. To avoid serious injury or death replace worn or damaged components immediately and keep the equipment out of use until repair is completed.

Daily Procedures

When using strong cleaning agents such as rubbing alcohol or bleach, it is advisable to test first in an inconspicuous area. Other cleaning agents may contain harsh or unknown solvents and are subject to formula changes by the product manufacturer without notice. Should you desire to use other cleaning agents, carefully try them in an inconspicuous area to determine potential damage to the material. Never use harsh solvents or cleaners which are intended for industrial applications. To clean stained or soiled areas, a soft white cloth is recommended. Avoid use of paper towels.

Cleaning products may be harmful/irritating to your skin, eyes, etc. Use protective gloves and eye protection. **Do Not** inhale or swallow any cleaning product. Protect surrounding area/clothing from exposure. Use in well ventilated area. Follow all product manufacturer's warnings. Cybex and its vendors cannot be held responsible for damage or injuries resulting from the use or misuse of cleaning products.

Clean Upholstery

If	Then
Light Soiling	<ol style="list-style-type: none"> 1. Prepare a solution of 10% household liquid soap and warm water. 2. Apply with a soft damp cloth. 3. If necessary, apply a solution of liquid cleanser with a soft bristle brush. 4. Dampen a clean soft cloth in water and wipe residue away.

If	Then
More Difficult Stains	<ol style="list-style-type: none"> 1. Prepare a solution of 10% household bleach (sodium hypochlorite) and 90% water. Dampen a soft white cloth in the solution. 2. Rub gently on the stained area. 3. Dampen a clean soft cloth in water and rinse area. 4. If stains are still present, a full strength household bleach may be used. Allow bleach to puddle on the affected area or apply with a bleached-soaked cloth for approximately 30 minutes. Dampen a clean soft cloth in water, and rinse area to remove any remaining bleach concentration.
More Difficult Stains (Alternative Method)	<ol style="list-style-type: none"> 1. Dampen a soft white cloth with rubbing alcohol. 2. Gently rub stained area. 3. Dampen a clean soft cloth in water and rinse area.
Restoring Luster	<ol style="list-style-type: none"> 1. Apply a light coat of furniture wax for 30 seconds. 2. Lightly rub area using a clean white cloth.

Clean Frames

Wipe down all frames using a mild solution of warm water and car wash soap. Be sure to dry thoroughly. **AVOID** acid or chlorine based cleaners and also cleaners containing abrasives as these could scratch or damage the equipment.

Clean Chrome

Clean chrome tubes, first using chrome polish and then using a car wax seal. Neutral cleaners with a pH between 5.5 and 8.5 are recommended. Be sure to dry thoroughly. **AVOID** acid or chlorine based cleaners and also cleaners containing abrasives as these could scratch or damage the equipment.

Guidelines for cleaning front panel:

Use clean soft cloths or sponges for application of cleaners and again for washing and rinsing. Follow up each application with warm water rinse.

- **DO NOT** use abrasives or high alkaline cleaners.
- **DO NOT** leave cleaners on for long periods, wash immediately.
- **DO NOT** apply cleaners in direct sunlight or at elevated temperatures.
- **DO NOT** use scrapers, squeegees, or razors.
- **DO NOT** clean with gasoline.

Compatible Cleaners and Detergents:

- Formula 409
- Top Job
- Joy
- Palmolive
- Windex with Ammonia D

To Minimize Fine or Hairline Scratches:

Mild automotive polish applied and removed with a soft clean cloth will help fill scratches.

Suggested Polishes:

- Johnson Paste Wax
- Mirror Glaze #10 Plastic Polish (by Mirror Bright Polish Co.)
- Novus Plastics Polish #1, #2 (By Novus Inc.)

Weekly Procedures

Inspect All Nuts and Bolts

Tighten all loose nuts and bolts as required.





WARNING Equipment hazard. To avoid serious injury or death replace worn or damaged components immediately and keep the equipment out of use until repair is completed.

Inspect Cables

Inspect all cables for wear or damage and proper tension. When inspecting cables, run fingers on the cable, paying particular attention to bends and attachment points.

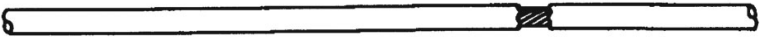
The following conditions may indicate a worn cable:

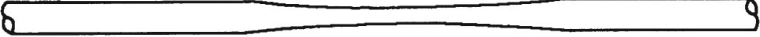
Condition of Cable	Diagram
A tear or crack in the cable sheath that exposes the cable	
A kink in the cable	
A curled sheath	
Necking - A stretched cable sheath	

Bars and Handles

Inspect bars and handles for wear, paying particular attention to tab area connection points.

CAUTION

Worn handles

- Do not use handles if less than 1/8" of material remains on edge.
- Replace all worn handles immediately.

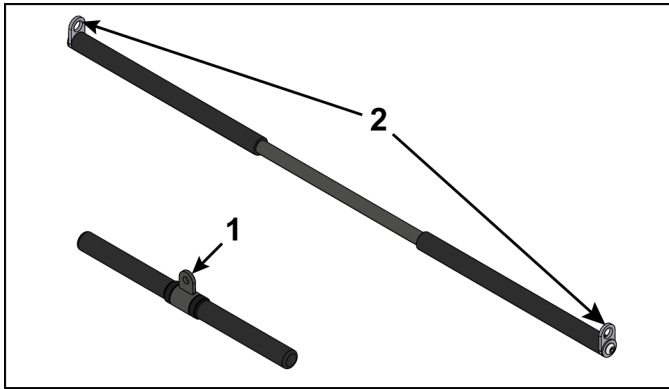

	Description	Qty
1	Attachment hole (Straight handle)	1
2	Attachment hole (Lat bar)	2

Inspection	Action
Inspect bars and handles for wear, paying particular attention to tab area connection points.	Replace all worn handles immediately.
Inspect snap links for proper latching (indicates wear).	Replace all worn snap links immediately.

Inspect Other Items

Inspect other items for proper operation, damage, or wear.

Inspection	Action
Inspect grips for looseness or wear.	Replace all loose or worn grips immediately.
Inspect all labeling for readability, including instructional placards, warning and caution decals.	Replace all worn labeling immediately.
Inspect all weight stacks for proper alignment and operation.	Correct all improper alignment and operation issues immediately.
Inspect guide rods for lubrication.	Wipe Weight Stack Guide Rods clean over entire length. Lubricate with a light coat of medium weight automotive engine oil.

Yearly Procedures

Replace all cables and belts annually

Cable Adjustment

Tools Required

9/16" Wrench (2)

Four types of cable tension adjustment are used on Cybex Strength Systems:

Jam Nut Adjustment

This type of adjustment uses a jam nut and a tension adjustment nut at the cable cam end as the primary adjustment. The other end of the cable usually contains a roll pin adjustment.

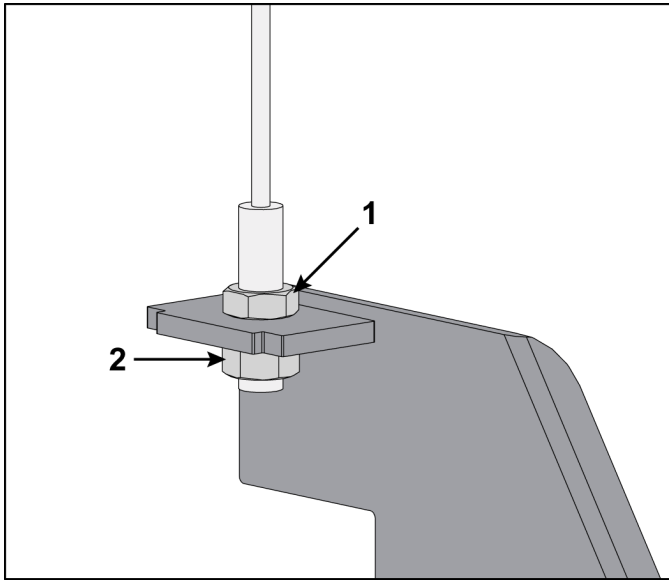

	Description	Qty.
1	Jam nut	1
2	Tension adjustment nut	1

Rod End Adjustment

This type of adjustment uses a socket head cap screw (SHCS) securing a cable rod end bearing to the machine. Primary adjustment is by turning the rod end bearing. The other end of the cable usually contains a roll pin cable adjustment.

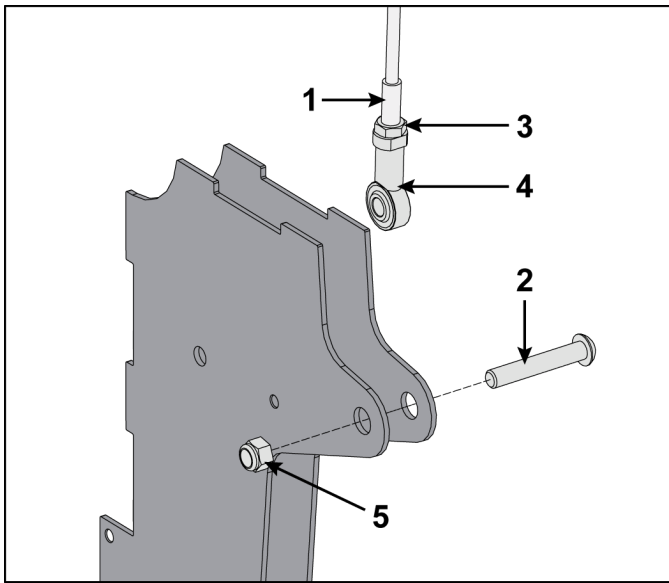

	Description	Qty.
1	Cable end	1
2	SHCS	1
3	Jam nut	1
4	Cable rod end bearing	1
5	Nylon locknut	1

Roll Pin Adjustment

This type of adjustment uses a roll pin and series of holes in the weight stack top weight connector.

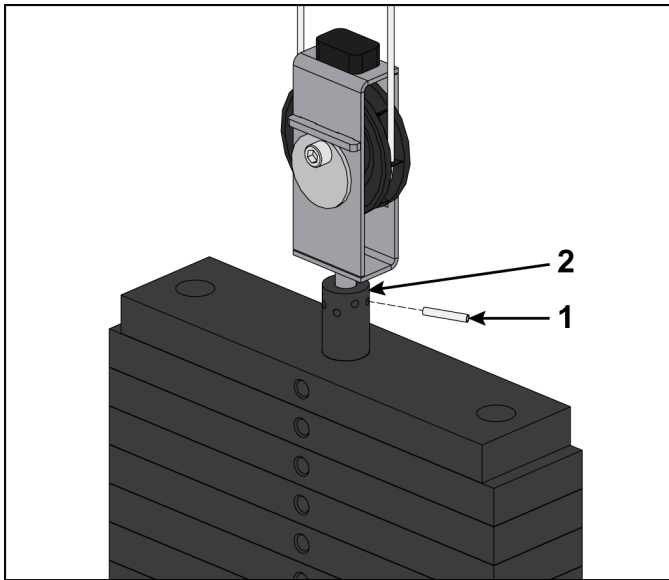

	Description	Qty.
1	Roll pin	1
2	Top weight connector	1

Cam End Adjustment

This type of adjustment uses an adjustment bolt on the pulley bracket. Loosen nut and rotate cam bolt to adjust cable.

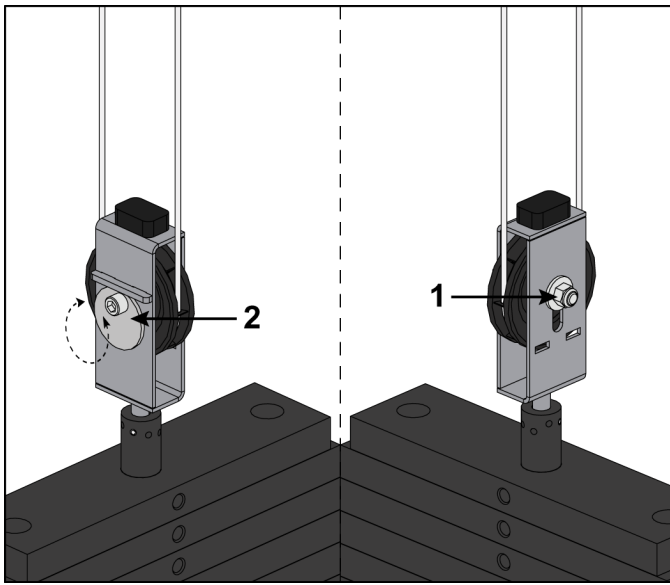

	Description	Qty.
1	Nut	1
2	Cam bolt adjustment	1

Customer Service

Product Registration

To register product do the following:.

1. Visit www.cybexintl.com.
2. Locate Product Registration in the Support section.
3. Fill out form completely.
4. Click the **Submit** button to register product.

Contacting Service

Hours of phone service are Monday through Friday from 8:30 a.m. to 6:00 p.m. Eastern Standard Time.

For Cybex customers living in the USA, contact Cybex Customer Service at 888-462-9239.

For Cybex customers living outside the USA, contact Cybex Customer Service at 508-533-4300 or fax 508-533-5183. Email address internationaltechhelp@cybexintl.com

Find information on the web at www.cybexintl.com.

To contact us online go to www.cybexintl.com.

Ordering Parts

To order parts online go to www.cybexintl.com.

To speak with a customer service representative, call 888-462-9239 (for customers living within the USA) or 508-533-4300 (for customers outside the USA).

The following information located on the serial number decal will assist our Cybex representatives in serving you.

- Unit Serial Number, Product Name and Model Number
- Part Description and Part Number if you have it. All parts can be found on the web at www.cybexintl.com
- Shipping Address
- Contact Name
- Include a description of the problem.

In addition to your shipping address and contact name, your account number is helpful but not required. You may also fax orders to 508-533-5183.

Return Material Authorization (RMA)

The Return Material Authorization (RMA) system is used when returning material for placement, repair or credit. The system assures that returned materials are properly handled and analyzed. Follow the following procedures carefully.

Contact your authorized Cybex dealer on all warranty-related matters. Your local Cybex dealer will request a RMA from Cybex, if applicable. Under no circumstances will defective parts or equipment be accepted by Cybex without proper RMA and an Automated Return Service (ARS) label.

Please contact [Cybex Customer Service](#) for the return of any item that is defective.

Provide the technician with a detailed description of the problem you are having or the defect in the item you wish to return. Provide the model and serial number of your Cybex equipment.

At Cybex's discretion, the technician may request that you return the problem part(s) to Cybex for evaluation and repair or replacement. The technician will assign you a RMA number and will send you an ARS label. The ARS label and the RMA numbers must be clearly displayed on the outside of the package that contains the item(s) to be returned. Include the description of the problem, the serial number of the equipment and the name and address of the owner in the package along with the part(s).

Merchandise returned without an RMA number on the outside of the package or shipments sent COD will not be accepted by the Cybex receiving department.

Damaged Parts

Materials damaged in shipment should not be returned for credit. Shipping damages are the responsibility of the carrier (UPS, Federal Express, trucking companies, etc.)

Apparent Damage

Upon receipt of your shipment, check all items carefully. Any damage seen with a visual check must be noted on the freight bill and signed by the carrier's agent. Failure to do so will result in the carriers refusal to honor your damage claim. The carrier will provide you with the required forms for filing such claims.

Concealed Damage

Damage not seen with a visual check upon receipt of a shipment but notices later must be reported to the carrier as soon as possible. Upon discovery of the damage, a written or phone request to the carrier asking them to perform an inspection of the materials must be made within ten days of the delivery date. Keep all shipping containers and packing materials as they will be needed in the inspection process. The carrier will provide you with an inspection report and the necessary forms for filing a concealed damage claim. Concealed damage claim is the carrier's responsibility.



10 Trotter Drive, Medway, MA 02053 • 888-462-9239 • 508-533-4300 • FAX 508-533-5183

www.cybexintl.com