



**Cybex Bravo Pull  
Owner's Manual  
Strength Systems  
Part Number 18021-999-4 A**

# Table of Contents

## **Safety**

Safety Guidelines And Practices .....	3
Securing Equipment .....	6
Regular Maintenance Activities .....	7
Warnings and Cautions .....	8
Label Placement .....	9

## **Assembly**

Machine Specifications .....	10
Tools Required .....	10
Assembly Procedure .....	10
Environment and Storage .....	16

## **Exercise**

Intended Use .....	17
Instructions .....	17

## **Maintenance**

Daily Procedures .....	19
Weekly Procedures .....	22
Yearly Procedures .....	24
Cable Adjustment .....	25
Belt Adjustment .....	26

## **Customer Service**

Product Registration .....	27
Contacting Service .....	27
Ordering Parts .....	28
Return Material Authorization (RMA) .....	28
Damaged Parts .....	29

Cybox® and the Cybox logo are registered trademarks of Cybox International, Inc.

DISCLAIMER: Cybox International, Inc., makes no representations or warranties regarding the contents of this manual. We reserve the right to revise this document at any time or to make changes to the product described within it without notice or obligation to notify any person of such revisions or changes.

© Copyright 2012, Cybox International, Inc. All rights reserved. Printed in the United States of America.

10 Trotter Drive Medway, MA 02053 • 508-533-4300 • FAX 508-533-5183 [www.cyboxintl.com](http://www.cyboxintl.com) • 18021-999-4 A • February 2012

# Safety

## Safety Guidelines And Practices

Cybox International partners with equipment owners to establish the safest and most effective setup of Cybox equipment. Cybox International urges each facility owner to carefully follow all safety precautions. Following these precautions are the best protection against personal injury or damage to equipment or facility.

The most important safety precaution is to maximize stability for every piece of equipment. The equipment should be securely anchored to the floor. It is imperative the floor be level.

Cybox recommends that all fitness equipment be used in a supervised area. It is recommended that the equipment be located in an access controlled area. Control is the responsibility of the owner. The extent of control is at the discretion of the owner.

It is the responsibility of the purchaser/owners of Cybox products to read and understand the owner's manual, and warning labels; as well as instruct all individuals, whether end users or supervising personnel, on proper usage of the equipment.

 Read the Owner's Manual carefully before assembling, servicing, or using the equipment. In an institutional environment, it is the facility owner's responsibility to properly instruct users on the proper operation of the equipment and to warn them of the potential hazards.



Follow and enforce the User Safety Precautions to protect both the user and the equipment. Keep children away from selectorized strength equipment. Teenagers or disabled users must be supervised.

Do not allow anyone, including trainers, to use equipment in a manner other than shown on the instructional placards located on every machine.

It is the responsibility of the facility owner and/or owner of the equipment to instruct users on proper operation of the equipment and review all labels.

 **WARNING:** *Serious injury or death could occur if these safety precautions are not followed:*

### User Safety Precautions

-  Read all warnings posted on the machine. Warnings are posted on each machine to alert the user to potential problems. *Following warning labels will prevent injury or equipment damage.*
-  Read and understand warning labels and instructional placards prior to exercising. Obtain instruction prior to use. *Each machine has instructions posted on the equipment for proper use.*

- Use the selectorized and plate loaded machines as shown on placards. **DO NOT** modify the machine.
- Never pin the weights in an elevated position. **DO NOT** use the machine if found in this condition. *Seek assistance from floor staff. Weights pinned up have the potential to fall if the user pulls the pin. Floor staff should lower the weights to prevent potential problems.*
- Be certain that the weight pin is completely inserted (for selectorized strength equipment that employ weight stacks). *If the pin is not completely inserted the user may accidentally drop the weights if the pin falls out.*
- Never use dumbbells or other means to incrementally increase the weight resistance. Use only those means provided by the manufacturer for the equipment. *Altering the machine design by adding additional weight as with dumbbells or other means can injure the user, may damage the equipment, and will void the warranty.*
- Set up, anchor, and operate selectorized strength equipment on a solid level surface. *If the floor is not level the equipment is not stable.*
- **DO NOT** wear loose or dangling clothing or jewelry while using selectorized strength equipment. Stay clear of all moving components. *Loose clothing or dangling jewelry can become entangled in moving parts and potentially cause severe injury or damage.*
- Consult a physician prior to commencing an exercise program. If at any time during exercise you feel faint, dizzy or experience pain, stop and consult your physician. *Users must be responsible and cautious with the condition of their own health. Consulting a physician before beginning a program can alert the user to the personal risk if health is an issue.*
- Use a spotter for Free Weight equipment. *A spotter adds an additional level of safety.*
- **DO NOT** exceed the maximum specified user weight. *Too much weight on a machine may prevent it from proper function or damage the machine.*
- **DO NOT** use if equipment appears damaged or inoperable upon inspection. *If the equipment appears damaged or inoperable- contact the floor staff.*
- **DO NOT** attempt to fix a broken or jammed equipment. Notify floor staff. *It is the owner's responsibility to repair broken or jammed equipment.*
- **DO NOT** use if guards are missing or damaged. A missing or broken guard should be replaced by a qualified technician. *Guards prevent things from interfering with function.*
- **DO NOT** remove any labeling from equipment. Replace any damaged labels. Labels give users specific information and alerts. *Replacing damaged labels ensures users can read the labels for information provided.*

## Facility Safety Precautions

-  Read the Owner's Manual carefully before assembling, servicing or using the equipment.
- It is the sole responsibility of the user/owner or facility operator to ensure that regular maintenance is performed.

- Inspect the equipment for worn or loose components prior to use. Tighten/replace any loose or worn components before to using. Pay close attention to belts, cables, grips or pulleys and their connections. Always look for potential problems in equipment condition. *Loose components should be tightened to function properly. Replacing worn components maintains the equipment is in the best condition for regular use.*
- To maximize stability, securely anchor each machine to the floor using the anchor holes provided in each machine. Each machine must be set up, anchored, and operated on a solid level surface.

**Do not install equipment on an uneven surface!**

**DANGER !**

Death or serious injury will occur if the following requirements are not met:



***Cybox is not able to anchor the equipment due to local building codes. The owner is responsible for the actual anchoring of equipment. Consult with a professional contractor.***

***Use fasteners having a minimum of 500 lbs. tensile capacity -- Cybox recommends 3/8" grade 2 bolts or better.***

***If legs/frame does not contact surface, DO NOT pull down with anchors. Shim any leg or frame not in contact with surface using flat washers.***

- Ensure that all users are properly trained on how to use the equipment.
- Verify there is enough room for safe access and operation of the equipment. Spacing requirements for each piece of equipment vary depending on placement. The Assembly section gives equipment dimensions but it is up to the facility to verify there is clearance between and around each machine to operate without interference.
- Perform regular maintenance checks on the equipment as detailed in the Maintenance section of this manual. Inspect all areas most susceptible to wear, including, (but not limited to) cables, pulleys, belts, and grips.
- Immediately replace worn or damaged components. If unable to immediately replace worn or damaged components then remove from service until the repair is made.
- Use only Cybox supplied components to maintain/repair the equipment.
- Keep a repair log of all maintenance activities.
- Display the Facility Safety Sign so it is visible and prominent.

## **Securing Equipment**

### **Do not use machine until it is properly anchored.**

The machine has holes in the feet, which allow for ease in anchoring to the floor. All anchoring holes must be used to maximize stability. Equipment must be secured to a solid, level surface to eliminate rocking, tipping, or falling over due to incorrect usage and misuse.

The solid, level surface should not deviate more than 1/8" over a 10' distance or as defined and required by local building and architectural codes.

Anchoring of equipment must be completed by a qualified licensed contractor.

Due to the wide variation of flooring on which machines may be anchored or installed, verify anchoring method and anchoring fasteners with a qualified and licensed contractor.

A minimum pull out force of 220 lbs/100 kgs is required for each anchor position.

### **PROPER USAGE**

Use equipment only as described in the manual or on the placards located on each machine. Failing to follow proper instructions may result in injury.

### **STANDARD COMPLIANCE**

Cybox products meets applicable ASTM and EN Standards.

## **Regular Maintenance Activities**

Preventative maintenance activities must be performed to maintain normal and safe operation of your equipment. Keeping a log sheet of all maintenance actions will assist you in staying current with all preventative maintenance activities. The preventative maintenance actions are described in detail in the maintenance section of this manual. Briefly, they include:

### **Daily**

Clean upholstery.

### **Weekly**

- Inspect all nuts and bolts for looseness. Tighten as required.
- Inspect all cables and belts for damage or wear. If a cable or belt is worn or damaged, immediately discontinue use until cable or belt has been replaced.
- Check for worn handles, worn snap links, and worn warning labeling. Replace all worn parts immediately.
- Inspect for loose or worn grips. Replace all loose or worn grips immediately.
- Inspect weight stacks for proper alignment and operation. Correct all improper alignment and operation issues immediately.
- Lubricate guide rods using automotive engine oil only.

### **Yearly**

Replace all cables and belts at least annually.

## Warnings and Cautions

Warning decals indicate a potentially hazardous situation that could result in death or serious injury if the precautions are not observed.

Caution decals indicate a potentially hazardous situation that could result in minor or moderate injury if the precautions are not observed.

The diagram following the decals show where each decal is located.

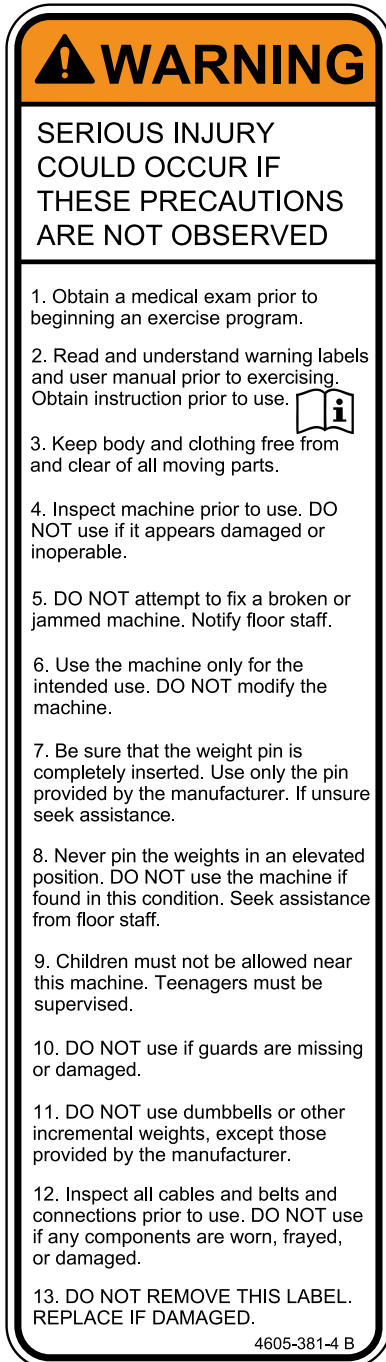

**Label Placement**

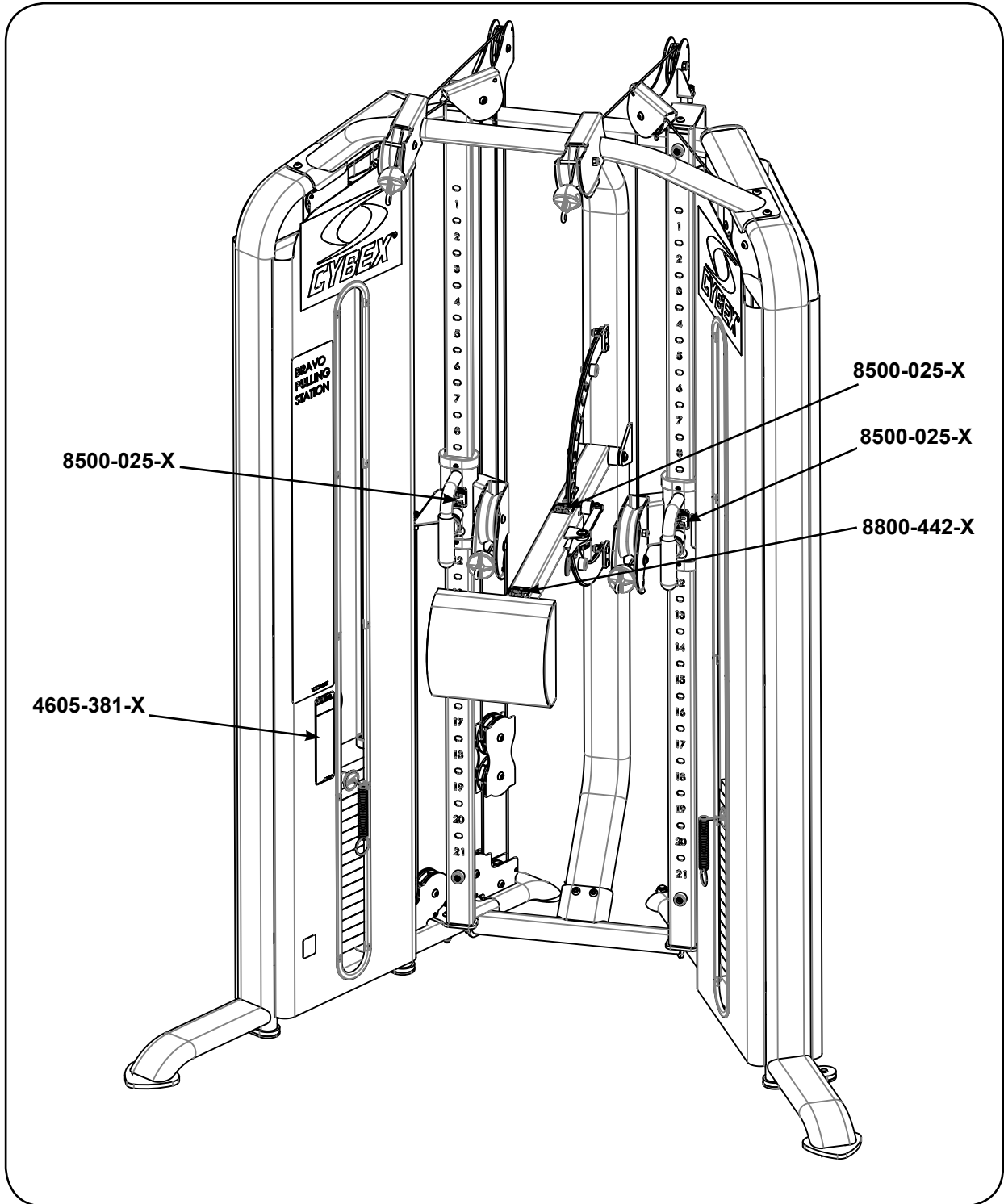

# Assembly

## Machine Specifications

Total Weight and Size 18021 Bravo Pull

Weight	Machine Dimensions at Rest	Machine Dimensions at Use
758 Lbs	62.70" W x 45.46" L x 90.70" H	62.70" W x 45.46" L x 90.70" H
344 Kg	159.26 cm W x 115.47 cm L x 230.38 H	159.26 cm W x 115.47 cm L x 230.38 H

The dimensions stated in the installation instructions are the recommended minimum dimensions as set forth by the manufacturer. The actual area for access and passage shall be the responsibility of the facility and should take into account any required local codes or regulations.



## Tools Required



- 9/16" Wrench
- 7/32" Allen wrench
- 3/4" Socket or wrench
- Hammer
- 3/16" Pin punch

## Assembly Procedure

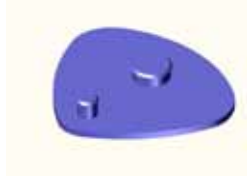
Two people will be required for this procedure.

 Read and understand all instructions thoroughly before assembling this unit. Check all items carefully. If there is damage, see the Customer Service section of this manual for proper procedure to return, replace, or reorder parts.

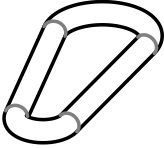
Qty	Part Number	Description	Diagram
4	16010-311	Foot Pad	
2	4800-557	Decal (10-150)	
4	12090-322	Foot Pad	

Qty	Part Number	Description	Diagram
4	GQ000206	Link	
4	8800-008	Handle Assembly	
1	51122	Strap	

**Placement**

If	Then
<b>18021 can fit through doorway</b>	<p><b>Two people will be required for this procedure</b></p> <ol style="list-style-type: none"> <li>1. Move to desired location.</li> <li>2. Remove the four shipping cones using a 3/4" socket wrench.</li> <li>3. Attach foot pads to each foot of frame.</li> </ol>

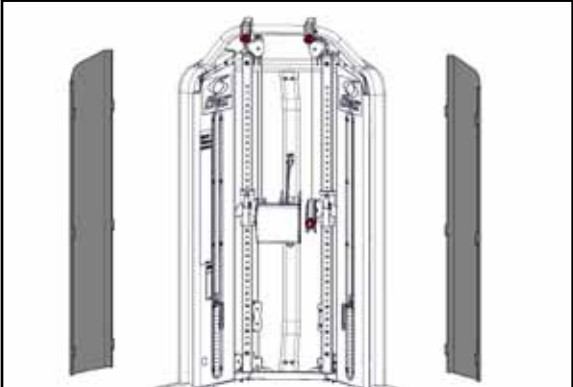
If	Then
<b>18021 cannot fit through doorway</b>	<p><b>Two people will be required for this procedure</b></p> <ol style="list-style-type: none"> <li>1. Remove the four shipping cones using a 3/4" socket or wrench.</li> <li>2. Attach foot pads to each foot of frame</li> <li>3. Remove back panels from machine.</li> </ol> <div align="center" data-bbox="574 1430 1143 1814">  </div>

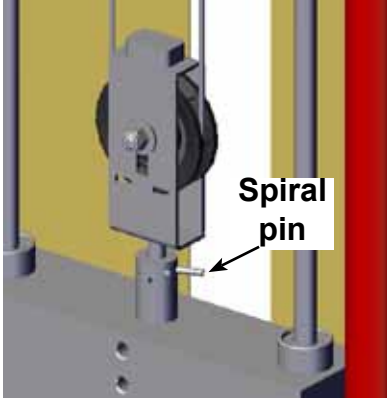
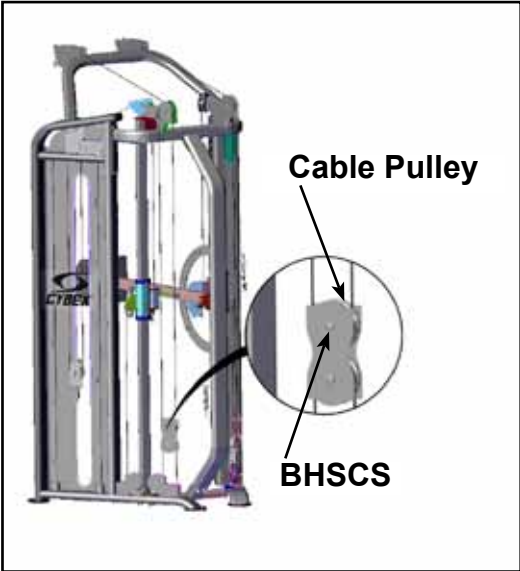
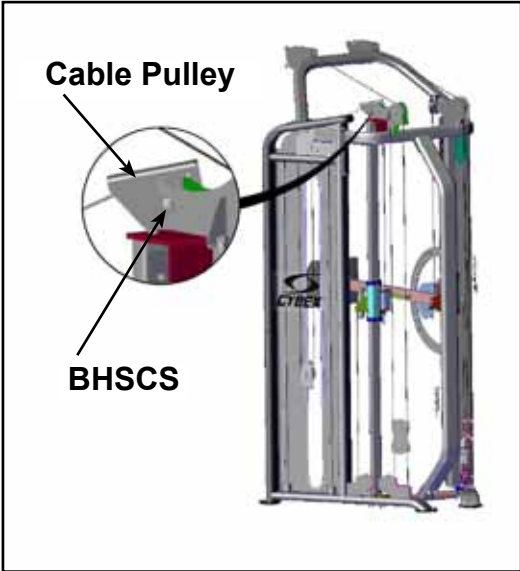
If	Then
<p><b>18021 cannot fit through doorway</b></p>	<ol style="list-style-type: none"> <li>4. Verify weight stack pin is disengaged.</li> <li>5. Remove spiral pin connecting pulley using a hammer and a 3/16" pin punch.</li> </ol>  <ol style="list-style-type: none"> <li>6. Move pulley and cable connections out of the way.</li> <li>7. Remove guide rod caps. Guide rod cap contains a compression spring that will fly if grasp is not released slowly. Slide spring loaded guide rod cap down guide rod until cap is clear of frame. Slowly release grasp of guide rod cap and remove.</li> <li>8. Remove lifting post.</li> <li>9. Remove weight plates.</li> </ol> <p><b>Remove cable pulley</b></p> <ol style="list-style-type: none"> <li>1. Remove button head socket cap screw (BHSCS) and locknut to remove cable pulley using a 7/32" Allen wrench and 9/16" wrench.</li> </ol> <div style="display: flex; justify-content: space-around;">   </div>

If	Then
<p>18021 cannot fit through doorway</p>	<p>2. Remove cable pulleys and cable out of the way.</p> <p><b>Separate Frame</b></p> <p>1. Remove BHSCS and locknuts securing one side of top front cross bar and top rear cross tube using a 7/32" Allen wrench and 9/16" wrench.</p> <div data-bbox="402 464 935 1062"> </div> <div data-bbox="954 464 1495 1062"> </div> <p>2. Remove the button head socket cap screw (BHSCS) securing adjustable post to frame using a 7/32" Allen wrench.</p> <div data-bbox="526 1192 1321 1864"> </div>

If	Then
<p>18021 cannot fit through doorway</p>	<p>3. Remove BHSCS and locknuts securing mounting tube to frame using a 7/32" Allen wrench and 9/16" wrench.</p> <div data-bbox="464 302 1390 865" style="border: 1px solid black; padding: 10px; margin: 10px 0;"> </div> <p>4. Move machine to desired location.</p> <p>5. Reattach frame halves and securely tighten the BHSCS and locknuts.</p>

### Securely anchor machine to the floor

Cyber strongly recommends to maximize stability, equipment must be secured to a solid level surface.

**CAUTION:** *Cyber is not responsible for the actual anchoring of equipment. Consult with a professional contractor.*

**WARNING:** *Use fasteners having a minimum of 500 lbs. tensile capacity (3/8" grade 2 bolts or better).*

**WARNING:** *If legs/frame does not contact surface, DO NOT pull down with anchors. Shim any leg or frame not in contact with surface using flat washers.*

## Install individual weight plates one at a time

1. Position each weight plate so wide edges of bushings face upward and narrow edges of bushings face downward.

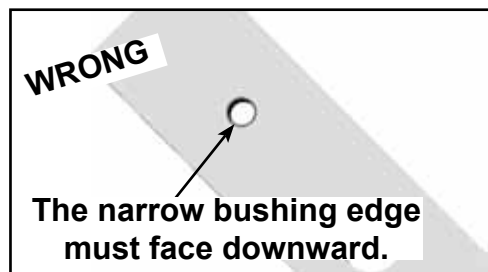
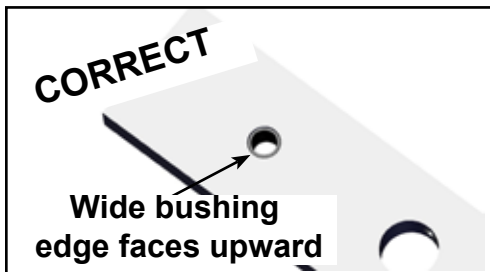

2. Install lifting post.
3. Snap guide rods in to position

## Cable routing

1. Reinstall removed pulleys.
2. Position pulley mount parallel to the top weight.
3. Pull down on pulley mount until cable is tight.
4. Verify cable is still routed through all pulleys.
5. Attach pulley mount to lifting post using a hammer and spiral pin.

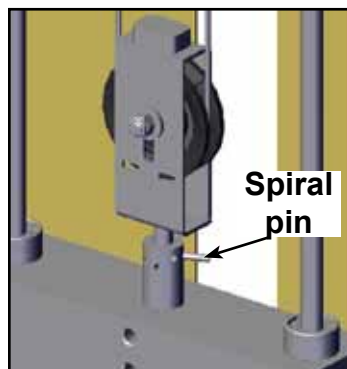

6. Lift top weight up and down simulating normal operation (without selecting any resistance).
7. Verify the cable is moving smoothly.

## Install back panels

## Verify proper operation

## **Environment and Storage**

### **Static Electricity**

To reduce static electricity increase the humidity.

### **Humidity**

The unit is designed to function normally in an environment with a relative humidity range of 30% to 75%. The unit can be shipped and stored in an environment with a relative humidity range of 10% to 90%.

### **Temperature**

The unit is designed to function normally in an environment with an ambient temperature range of 50° F (10° C) to 104° F (40° C). The unit can be shipped and stored in an environment with a relative humidity range of 10% to 90%.

Do not install, use, or store the unit in an area of high humidity, such as near a steam room, sauna, indoor pool or outdoors. Extensive exposure to water vapor, chlorine and/or bromine could adversely affect the equipment.

# Exercise

## Intended Use

The intended commercial use of this machine is to aid exercise and improve general physical fitness.

## Instructions

 Read and understand all instructions and warnings prior to using this machine in the Safety section of the Owner's Manual.

1. Select appropriate resistance.
2. Adjust handles for desired pulley height.
3. Adjust stabilization pad height for desired stabilization.
4. Ensure all adjustment knobs are locked into place.

 **CAUTION:** *Serious injury can result if precautions are not followed. Use equipment only as described in placards located on each machine. Failure to use in the manner depicted can result in injury.*

### LAT PULL

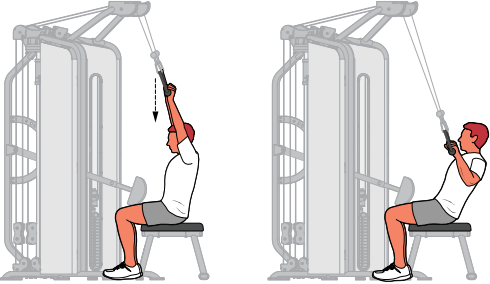

The diagram shows a person sitting on a bench, pulling a handle from a high pulley down towards their chest. Below the main illustration are three anatomical diagrams of the human body: a side view, a front view, and a back view, with the muscles used in the exercise highlighted in red.

**Motions Developed**  
Shoulder Adduction, Elbow Flexion

**Muscles Used**  
Latissimus Dorsi, Teres Major, Middle Trapezius, Rhomboid, Biceps

### HI ROW

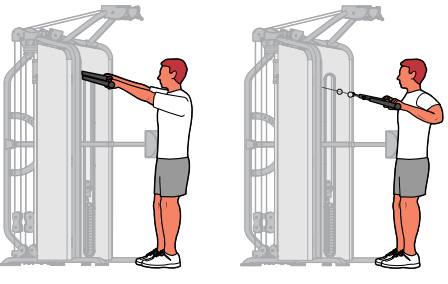

The diagram shows a person standing and pulling a handle from a high pulley towards their chest. Below the main illustration are three anatomical diagrams of the human body: a side view, a front view, and a back view, with the muscles used in the exercise highlighted in red.

**Motions Developed**  
Shoulder Extension, Elbow Flexion

**Muscles Used**  
Latissimus Dorsi, Teres Major, Middle Trapezius, Rear Deltoid, Rhomboid, Biceps

### MID ROW

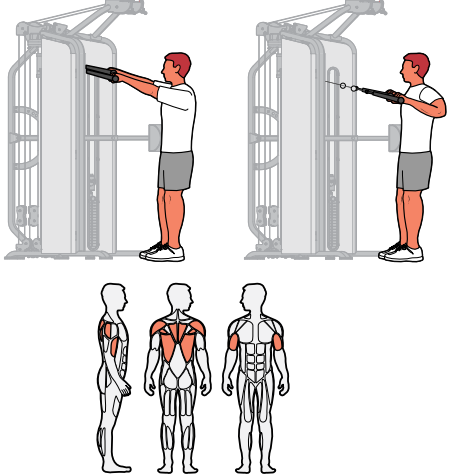

**Motions Developed**  
Shoulder Extension, Elbow Flexion

**Muscles Used**  
Latissimus Dorsi, Teres Major,  
Middle Trapezius, Rear Deltoid,  
Rhomboid, Biceps

### LOW ROW

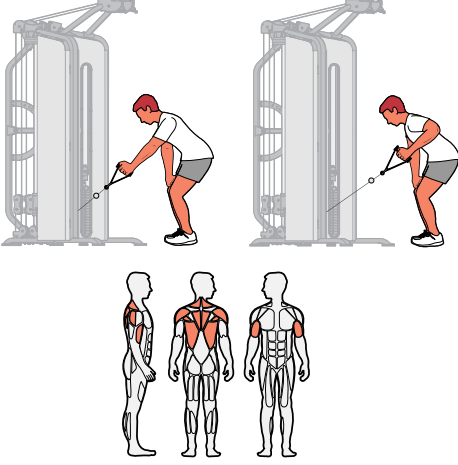

**Motions Developed**  
Shoulder Extension, Elbow Flexion

**Muscles Used**  
Latissimus Dorsi, Teres Major,  
Middle Trapezius, Rear Deltoid,  
Rhomboid, Biceps

### REAR DELT

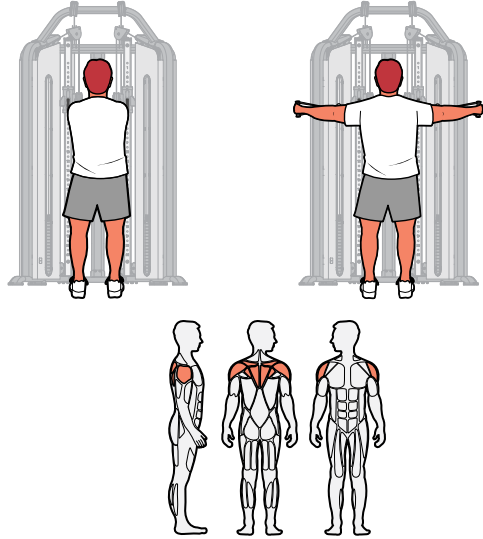

**Motions Developed**  
Horizontal Shoulder Extension

**Muscles Used**  
Rear Deltoid, Rhomboid, Trapezius,

## Maintenance

All preventive maintenance activities must be performed on a regular basis. Performing routine preventive maintenance actions can aid in providing safe, trouble-free operation of all Cybox Strength Systems equipment.

Cybox is not responsible for performing regular inspection and maintenance actions for your machines. Instruct all personnel in equipment inspection and maintenance actions and also in accident reporting/recording. Cybox representatives are available to answer any questions that you may have.

**All inspections and repairs must be performed by trained service personnel only. Cybox will void warranty if non-Cybox replacement parts are used.**

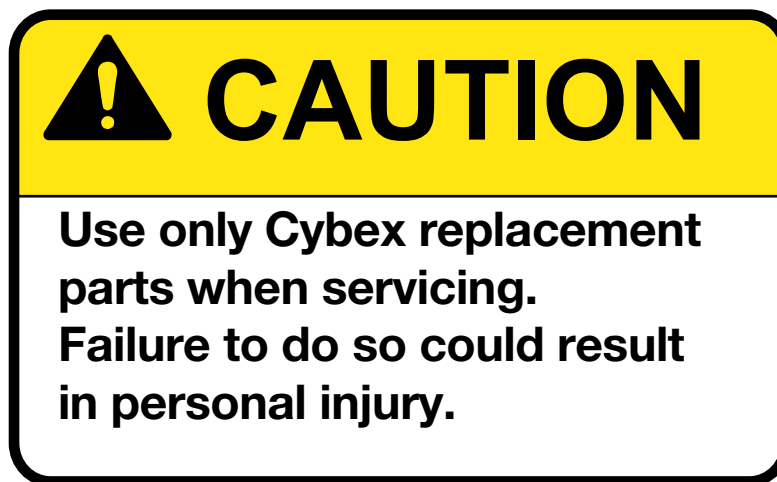

### Daily Procedures

When using strong cleaning agents such as rubbing alcohol or bleach, it is advisable to first test in an inconspicuous area. Other cleaning agents may contain harsh or unknown solvents and are subject to formula changes by the product manufacturer without notice. Should you desire to use other cleaning agents, carefully try them in an inconspicuous area to determine potential damage to the material. Never use harsh solvents or cleaners which are intended for industrial applications. To clean stained or soiled areas, a soft white cloth is recommended. Avoid use of paper towels.

Cleaning products may be harmful/irritating to your skin, eyes, etc. Use protective gloves and eye protection. **Do Not** inhale or swallow any cleaning product. Protect surrounding area/clothing from exposure. Use in well ventilated area. Follow all product manufacturer's warnings. CYBEX and its vendors cannot be held responsible for damage or injuries resulting from the use or misuse of cleaning products.

**Clean Upholstery**

If	Then
<p><b>Light Soiling</b></p>	<ol style="list-style-type: none"> <li>1. Prepare a solution of 10% household liquid soap and warm water.</li> <li>2. Apply with a soft damp cloth.</li> <li>3. If necessary, apply a solution of liquid cleanser with a soft bristle brush.</li> <li>4. Dampen a clean soft cloth in water and wipe residue away.</li> </ol>
<p><b>More Difficult Stains</b></p>	<ol style="list-style-type: none"> <li>1. Prepare a solution of 10% household bleach (sodium hypochlorite) and 90% water. Dampen a soft white cloth in the solution.</li> <li>2. Rub gently on the stained area.</li> <li>3. Dampen a clean soft cloth in water and rinse area.</li> <li>4. If stains are still present, a full strength household bleach may be used. Allow bleach to puddle on the affected area or apply with a bleached-soaked cloth for approximately 30 minutes. Dampen a clean soft cloth in water, and rinse area to remove any remaining bleach concentration.</li> </ol>
<p><b>More Difficult Stains (Alternative Method)</b></p>	<ol style="list-style-type: none"> <li>1. Dampen a soft white cloth with rubbing alcohol.</li> <li>2. Gently rub stained area.</li> <li>3. Dampen a clean soft cloth in water and rinse area.</li> </ol>
<p><b>Restoring Luster</b></p>	<ol style="list-style-type: none"> <li>1. Apply a light coat of furniture wax for 30 seconds.</li> <li>2. Lightly rub area using a clean white cloth.</li> </ol>

**Clean Frames**

Wipe down all frames using a mild solution of warm water and car wash soap. Be sure to dry thoroughly. **AVOID** acid or chlorine based cleaners and also cleaners containing abrasives as these could scratch or damage the equipment.

## **Clean Chrome**

Clean chrome tubes, first using chrome polish and then using a car wax seal. Neutral cleaners with a pH between 5.5 and 8.5 are recommended. Be sure to dry thoroughly. AVOID acid or chlorine based cleaners and also cleaners containing abrasives as these could scratch or damage the equipment.

### **Guidelines for cleaning front panel:**

Use clean soft cloths or sponges for application of cleaners and again for washing and rinsing. Follow up each application with warm water rinse.

- **DO NOT** use abrasives or high alkaline cleaners.
- **DO NOT** leave cleaners on for long periods, wash immediately.
- **DO NOT** apply cleaners in direct sunlight or at elevated temperatures.
- **DO NOT** use scrapers, squeegees, or razors.
- **DO NOT** clean with gasoline.

### **Compatible Cleaners and Detergents:**

- Formula 409
- Top Job
- Joy
- Palmolive
- Windex with Ammonia D

### **To Minimize Fine or Hairline Scratches:**

Mild automotive polish applied and removed with a soft clean cloth will help fill scratches.

### **Suggested Polishes:**

- Johnson Paste Wax
- Mirror Glaze #10 Plastic Polish (by Mirror Bright Polish Co.)
- Novus Plastics Polish #1, #2 (By Novus Inc.)

**Weekly Procedures**

**Inspect All Nuts and Bolts**

Tighten all loose nuts and bolts as required.



**WARNING:** *Serious injury or death may result if the following precautions are not followed. Replace all worn cables and belts. Worn cables and belts can fail if not replaced.*







**Inspect cables and belts**

Inspect all cables and belts for wear or damage and proper tension. When inspecting cables and belts, run fingers on the cable or belt, paying particular attention to bends in cables and attachment points. The following conditions may indicate a worn cable:

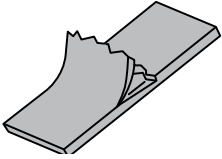
**Cables**

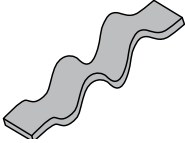
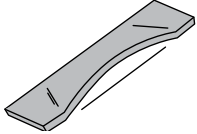
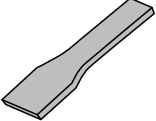
Condition of Cable	Diagram
A tear or crack in the cable sheath that exposes the cable	<p>A horizontal line representing a cable. In the middle, there is a small gap where the outer sheath is missing, exposing the inner core. The gap is shaded with diagonal lines to indicate the exposed interior.</p>
A kink in the cable	<p>A horizontal line representing a cable. It has a sharp V-shaped bend or kink in the middle, where the cable is sharply folded back on itself.</p>
A curled sheath	<p>A horizontal line representing a cable. The outer sheath is wavy and curved upwards in the middle, indicating it is not straight.</p>
Necking - A stretched cable sheath	<p>A horizontal line representing a cable. The middle section is significantly thinner than the ends, indicating the sheath has stretched and become weak.</p>

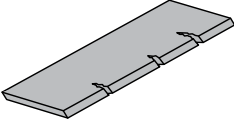
**Belts**

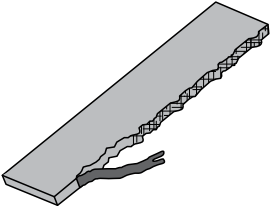
Condition of Belt	3D View	3D or Side View
Peeling of the belt's skin.		
Wave in belt		
Belt is necked down (narrow section)	<p data-bbox="654 632 984 779">Replace belt if any section is over 1/32" (.03) narrower than the rest of belt</p> 	<p data-bbox="1000 632 1498 737">Examine edge of belt (both sides). Replace belt if any section is narrower than the rest.</p> 
Cracks or splits		
One or more strands of kevlar is hanging out, or if there is a significant amount of frayed kevlar.		



**CAUTION:** *Personal injury or property damage may occur if the following precautions are not followed. Do not use if less than 1/8" of material remains to the edge. Replace all worn handles immediately. Failure to replace worn handles can result in injury or property damage.*

Inspect bars and handles for wear, paying particular attention to tab area connection points.

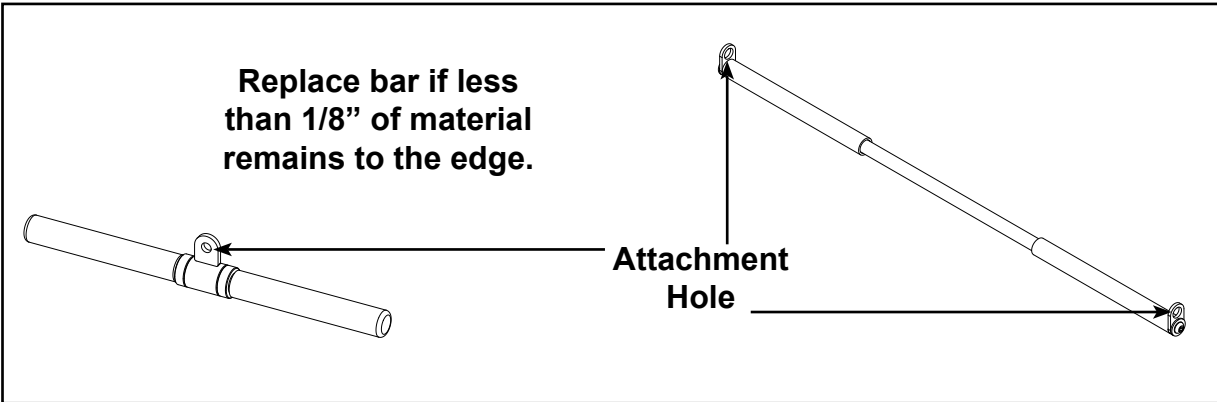

Inspection	Action
Inspect bars and handles for wear, paying particular attention to tab area connection points.	Replace all worn handles immediately.
Inspect snap links for proper latching (indicates wear).	Replace all loose or worn grips immediately.
Inspect all labeling for readability, including instructional placards, warning and caution decals.	Replace all worn labeling immediately.
Inspect all weight stacks for proper alignment and operation.	Correct all improper alignment and operation issues immediately.
Inspect guide rods for lubrication.	Wipe Weight Stack Guide Rods clean over entire length. Lubricate with a light coat of medium weight automotive engine oil.

## Yearly Procedures

Replace all cables and belts annually

## Cable Adjustment

### Tools Required

9/16" Wrench (2)

Four types of cable tension adjustment are used on Cybox Strength Systems:

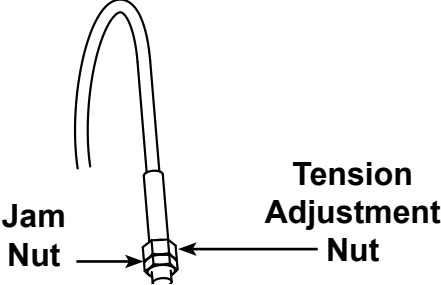
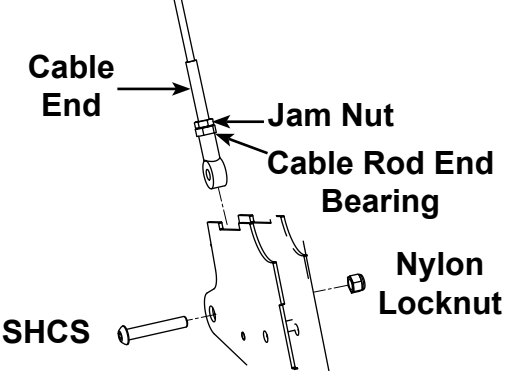
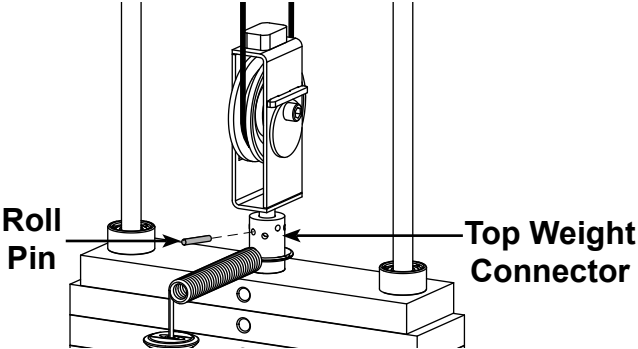
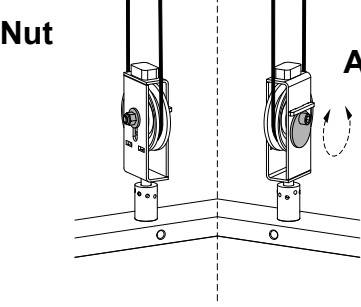
Cable Adjustment	Description	Diagram
Jam Nut Adjustment	This type of adjustment uses a jam nut and a tension adjustment nut at the cable cam end as the primary adjustment. The other end of the cable usually contains a roll pin adjustment.	 <p>The diagram shows a cable with a curved end. A 'Jam Nut' is positioned on the cable, and a 'Tension Adjustment Nut' is positioned further down the cable. Arrows point from the labels to the respective nuts.</p>
Rod End Adjustment	This type of adjustment uses a socket head cap screw (SHCS) securing a cable rod end bearing to the machine. Primary adjustment is by turning the rod end bearing. The other end of the cable usually contains a roll pin cable adjustment.	 <p>The diagram shows a cable rod end bearing assembly. Labels include 'Cable End', 'Jam Nut', 'Cable Rod End Bearing', 'SHCS' (socket head cap screw), and 'Nylon Locknut'. Arrows point from the labels to the corresponding parts.</p>
Roll Pin Adjustment	This type of adjustment uses a roll pin and series of holes in the weight stack top weight connector.	 <p>The diagram shows a weight stack with a 'Top Weight Connector' and a 'Roll Pin'. Arrows point from the labels to the respective parts.</p>
Cam End Adjustment	This type of adjustment uses an adjustment bolt on the pulley bracket. Loosen nut and rotate cam bolt to adjust cable.	 <p>The diagram shows a pulley bracket with a 'Nut' and a 'Cam Bolt Adjustment'. Arrows point from the labels to the respective parts.</p>

## Belt Adjustment

### Tools Required

- 7/32" Wrench
- Torque wrench (lbs-in)

Belt Adjustment	Action
Loose Belt	<ol style="list-style-type: none"><li>1. Using a 7/32" Allen wrench loose set screws.</li><li>2. Pull belt tight.</li><li>3. Secure belt in place with set screws.</li><li>4. Torque set screws to 300-350 lb-in.</li><li>5. Verify that the belt is moving smoothly and is routed straight from the top pulley bracket to the to weight belt clamp</li></ol>

# Customer Service

## Product Registration

To register product do the following:

1. Visit [www.cybexintl.com](http://www.cybexintl.com).
2. Locate Product Registration in the Support section.
3. Fill out form completely.
4. Click the Submit button to register product.

## Contacting Service

Hours of phone service are Monday through Friday from 8:30 a.m. to 6:00 p.m. Eastern Standard Time.

For Cybex customers living in the USA, contact Cybex Customer Service at 888-462-9239.

For Cybex customers living outside the USA, contact Cybex Customer Service at 508-533-4300 or fax 508-533-5183. email address [internationaltechhelp@cybexintl.com](mailto:internationaltechhelp@cybexintl.com)

Find information on the web at [www.cybexintl.com](http://www.cybexintl.com).

To contact us online go to [www.cybexintl.com](http://www.cybexintl.com). Select Support > Service. In the left navigation panel, click Get Service - Service Request Form. Fill out form completely and click the Submit Query button

## Ordering Parts

To order parts online go to [www.cybexintl.com](http://www.cybexintl.com). Select Support > Parts / Ordering. In the left navigation panel, click Parts Diagrams - Current Products. Select from the drop down boxes.

To speak with a customer service representative, call 888-462-9239 (for customers living within the USA) or 508-533-4300 (for customers outside the USA).

The following information located on the serial number decal will assist our Cybex representatives in serving you.

- Unit Serial Number, Product Name and Model Number
- Part Description and Part Number if you have it. All parts can be found on the web at [www.cybexintl.com](http://www.cybexintl.com)
- Shipping Address
- Contact Name
- Include a description of the problem.

In addition to your shipping address and contact name, your account number is helpful but not required. You may also fax orders to 508-533-5183.

## Return Material Authorization (RMA)

The Return Material Authorization (RMA) system is used when returning material for placement, repair or credit. The system assures that returned materials are properly handled and analyzed. Follow the following procedures carefully.

Contact your authorized Cybex dealer on all warranty-related matters. Your local Cybex dealer will request a RMA from Cybex, if applicable. Under no circumstances will defective parts or equipment be accepted by Cybex without proper RMA and an Automated Return Service (ARS) label.

Please contact Cybex Customer Service for the return of any item that is defective.

Provide the technician with a detailed description of the problem you are having or the defect in the item you wish to return. Provide the model and serial number of your Cybex equipment.

At Cybex's discretion, the technician may request that you return the problem part(s) to Cybex for evaluation and repair or replacement. The technician will assign you a RMA number and will send you an ARS label. The ARS label and the RMA numbers must be clearly displayed on the outside of the package that contains the item(s) to be returned. Include the description of the problem, the serial number of the equipment and the name and address of the owner in the package along with the part(s).

Merchandise returned without an RMA number on the outside of the package or shipments sent COD will not be accepted by the Cybex receiving department.

## ***Damaged Parts***

Materials damaged in shipment should not be returned for credit. Shipping damages are the responsibility of the carrier (UPS, Federal Express, trucking companies, etc.)

### **Apparent Damage**

Upon receipt of your shipment, check all items carefully. Any damage seen with a visual check must be noted on the freight bill and signed by the carrier's agent. Failure to do so will result in the carriers refusal to honor your damage claim. The carrier will provide you with the required forms for filing such claims.

### **Concealed Damage**

Damage not seen with a visual check upon receipt of a shipment but notices later must be reported to the carrier as soon as possible. Upon discovery of the damage, a written or phone request to the carrier asking them to perform an inspection of the materials must be made within ten days of the delivery date. Keep all shipping containers and packing materials as they will be needed in the inspection process. The carrier will provide you with an inspection report and the necessary forms for filing a concealed damage claim. Concealed damage claim is the carrier's responsibility.







10 Trotter Drive Medway, MA 02053 • 508-533-4300 • FAX 508-533-5183

[www.cybexintl.com](http://www.cybexintl.com)