



**VR1® Leg Press**  
**Owner's and Service Manual**  
Strength Systems  
Part Number 13040-999-4 A





**VR1<sup>®</sup> Leg Press**  
**Owner's and Service Manual**  
**Strength Systems**  
Part Number 13040-999-4 A

Cybex<sup>®</sup> and the Cybex logo are registered trademarks of Cybex International, Inc.  
VR1<sup>®</sup> and its mark are registered trademarks of Cybex International, Inc.

**DISCLAIMER:** Cybex International, Inc., makes no representations or warranties regarding the contents of this manual. We reserve the right to revise this document at any time or to make changes to the product described within it without notice or obligation to notify any person of such revisions or changes.

© Copyright 2008, Cybex International, Inc. All rights reserved.

Printed in the United States of America.  
10 Trotter Drive Medway, MA 02053 • 508-533-4300 • FAX 508-533-5183  
www.cybexinternational.com • techhelp@cybexintl.com • techpubs@cybexintl.com • 13040-999-4 A • June 2008



# Table of Contents

## i Table of Contents

### **1 Safety**

Safety .....	1-1
Warning/Caution Decals .....	1-2
Regular Maintenance Activities.....	1-5
Using Proper Form .....	1-5

### **2 Exercises**

Intended Use. . . . .	2-1
Instructions. . . . .	2-2

### **3 Customer Service**

Contacting Service .....	3-1
Ordering parts .....	3-1
Return Material Authorization (RMA). . . . .	3-2
Damaged Parts .....	3-3

### **4 Assembly** .....

4-1

### **5 Maintenance**

Daily Procedures .....	5-1
Weekly Procedures .....	5-4
Yearly Procedures .....	5-6
Environment. . . . .	5-7
Storage .....	5-7

### **6 Service** .....

6-1



# 1 - Safety

## Safety

Read the Owner's manual carefully before assembling, servicing or using the equipment.

It is the responsibility of the facility owner and/or owner of the equipment to instruct users on proper operation of the equipment and review all labels.

***!Warning: Serious injury could occur if these safety precautions are not observed:***

### User Safety Precautions

- Obtain a medical exam prior to beginning an exercise program.
- Read and understand warning labels and user manual prior to exercising. Obtain instruction prior to use. 
- Keep body and clothing free from and clear of all moving parts.
- Inspect machine prior to use. **DO NOT** use if it appears damaged or inoperable.
- **DO NOT** attempt to fix a broken or jammed machine. Notify floor staff.
- Use the machine only for the intended use. **DO NOT** modify the machine.
- Be sure that the weight pin is completely inserted. Use only the pin provided by the manufacturer. If unsure, seek assistance.
- Never pin the weights in an elevated position. **DO NOT** use the machine if found in this condition. Seek assistance from floor staff.
- Children must not be allowed near these machines. Teenagers must be supervised.
- **DO NOT** use if guards are missing or damaged.
- **DO NOT** use dumbbells or other incremental weights, except those provided by the manufacturer.
- Inspect all cables and belts and connections prior to use. **DO NOT** use if any components are worn, frayed or damaged.
- **DO NOT** remove any labeling from equipment. Replace any damaged labels.
- Stop exercising if you feel faint, dizzy or experience pain at any time while exercising and consult your physician.

## Facility Safety Precautions

- Read the Owner's Manual carefully before assembling, servicing or using the equipment.
- Securely anchor each machine to the floor using the anchor holes provided in each machine.

**NOTE:** *Cybox is not responsible for the actual anchoring of equipment. Consult with a professional contractor.*

**NOTE:** *Use fasteners having a minimum of 500 lbs. tensile capacity (3/8" grade 2 bolts or better).*

**NOTE:** *If legs/frame does not contact surface, **DO NOT** pull down with anchors. Shim any leg or frame not in contact with surface using flat washers.*

- Make sure that each machine is set up and operated on a solid level surface. **Do not install equipment on an uneven surface.**
- Make sure that all users are properly trained on how to use the equipment.
- Make sure there is enough room for safe access and operation of the equipment.
- Perform regular maintenance checks on the equipment. Also pay close attention to all areas most susceptible to wear, including (but not limited to) cables, pulleys, belts and grips.
- Immediately replace worn or damaged components. If unable to immediately replace worn or damaged components, then remove from service until the repair is made.
- Use only Cybox supplied components to maintain/repair the equipment.
- Keep a repair log of all maintenance activities.
- Inspect all cables and belts and connections prior to use. **DO NOT** use if any components are worn, frayed or damaged.

**NOTE:** *It is the sole responsibility of the user/owner or facility operator to ensure that regular maintenance is performed.*

### Warning/Caution Decals

Warning decals indicate a potentially hazardous situation, which, if not avoided, could result in death or serious injury.

Caution decals indicate a potentially hazardous situation, which, if not avoided, could result in minor or moderate injury.

The warning and caution decals are shown on the following page. The diagrams following the decals show where each decal is located.



**! WARNING**

**SERIOUS INJURY  
COULD OCCUR IF  
THESE PRECAUTIONS  
ARE NOT OBSERVED**

1. Obtain a medical exam prior to beginning an exercise program.
2. Read and understand warning labels and user manual prior to exercising. Obtain instruction prior to use. 
3. Keep body and clothing free from and clear of all moving parts.
4. Inspect machine prior to use. DO NOT use if it appears damaged or inoperable.
5. DO NOT attempt to fix a broken or jammed machine. Notify floor staff.
6. Use the machine only for the intended use. DO NOT modify the machine.
7. Be sure that the weight pin is completely inserted. Use only the pin provided by the manufacturer. If unsure seek assistance.
8. Never pin the weights in an elevated position. DO NOT use the machine if found in this condition. Seek assistance from floor staff.
9. Children must not be allowed near this machine. Teenagers must be supervised.
10. DO NOT use if guards are missing or damaged.
11. DO NOT use dumbbells or other incremental weights, except those provided by the manufacturer.
12. Inspect all cables and belts and connections prior to use. DO NOT use if any components are worn, frayed, or damaged.
13. DO NOT REMOVE THIS LABEL. REPLACE IF DAMAGED.

4605-381-4 A



**! CAUTION**

**Failure to correctly  
adjust could result in  
personal injury.  
Always fully engage  
the detent pin before  
use to avoid injury.**

8500-025-4

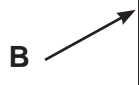

**! CAUTION**



**Keep away from moving  
parts. Failure to do so could  
result in personal injury.**

8500-026-4

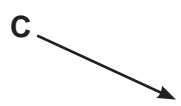

Leg Press - 13040

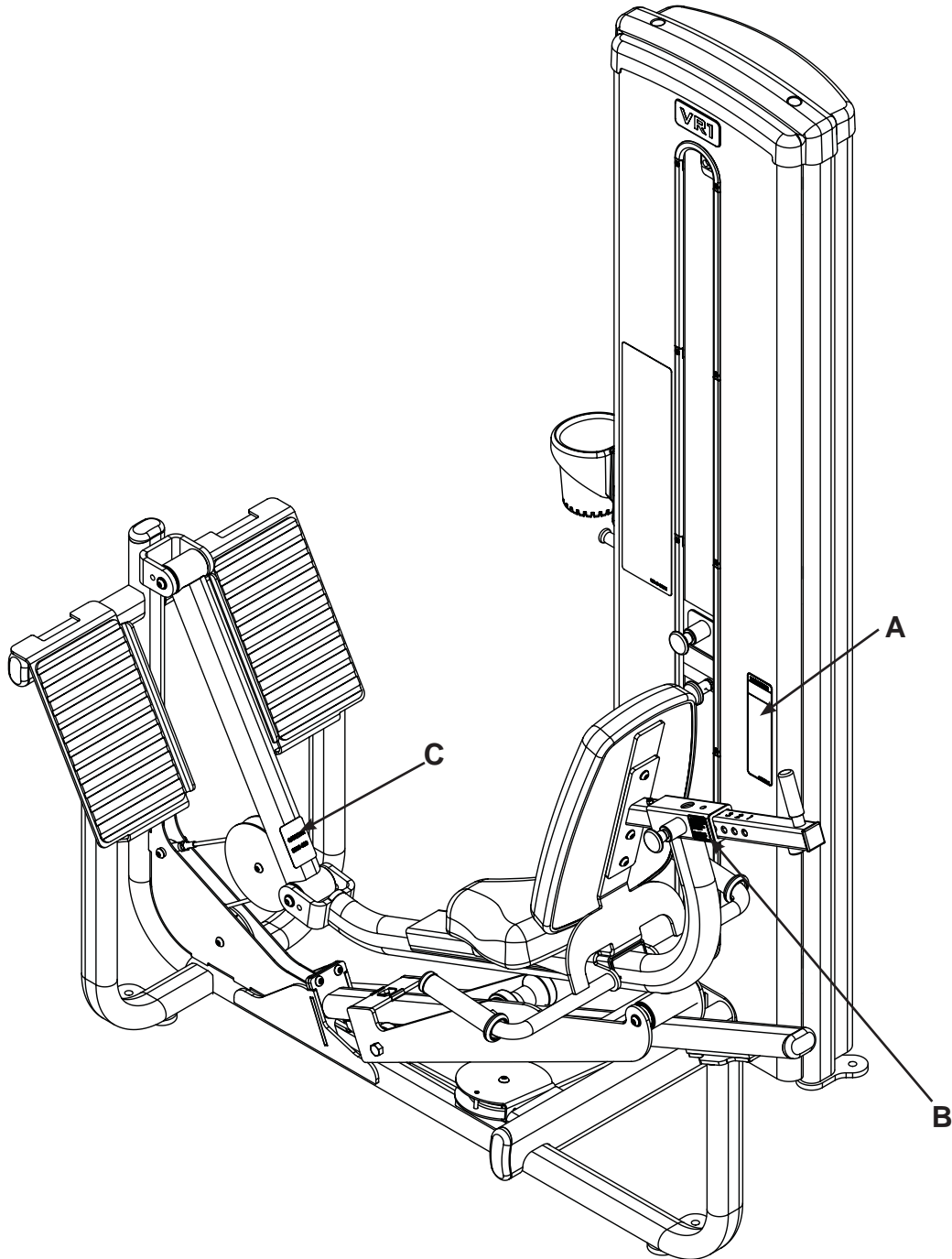

**Description**

**Part No.**

- A. Warning Label.....4605-381-4
- B. Caution Decal.....8500-025-4
- C. Caution Decal.....8500-026-4

## Regular Maintenance Activities

Preventative maintenance activities must be performed to maintain normal operation of your equipment. Keeping a log sheet of all maintenance actions will assist you in staying current with all preventative maintenance activities. The preventative maintenance actions are described in detail in Chapter 5. Briefly, they include:

### Daily

1. Clean upholstery.

### Weekly

1. Inspect all nuts and bolts for looseness. Tighten as required.
2. Inspect all cables and belts for damage or wear (see Chapter 5). *If a cable or belt is worn or damaged, immediately discontinue use until cable or belt has been replaced.*
3. Check for worn handles, worn snap links, and worn warning labeling. Replace all worn parts immediately.
4. Inspect for loose or worn grips. Replace all loose or worn grips immediately.
5. Inspect weight stacks for proper alignment and operation. Correct all improper alignment and operation issues immediately.
6. Lubricate guide rods using automotive engine oil only.

### Yearly

1. Replace all cables and belts at least annually.

## Using Proper Form

Before working out, read and understand the exercises located on the placard and in Chapter 2.

*This page intentionally left blank*

## 2 - Exercise

### Intended Use

The intended use of this equipment is to aid or improve general physical fitness and exercise. For Commercial use.

### Instructions

Read and understand all instructions and warnings prior to using this machine. See Chapter 1, Safety, in the Owner's Manual or consult with floor staff.

### MUSCLES USED

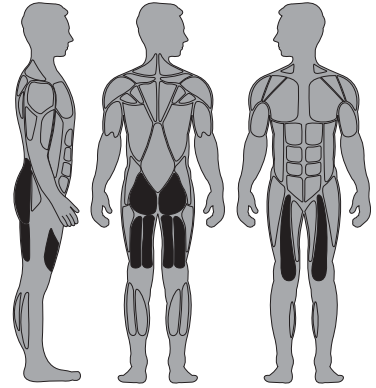

Quadriceps, Gluteus Maximus,  
Hamstrings

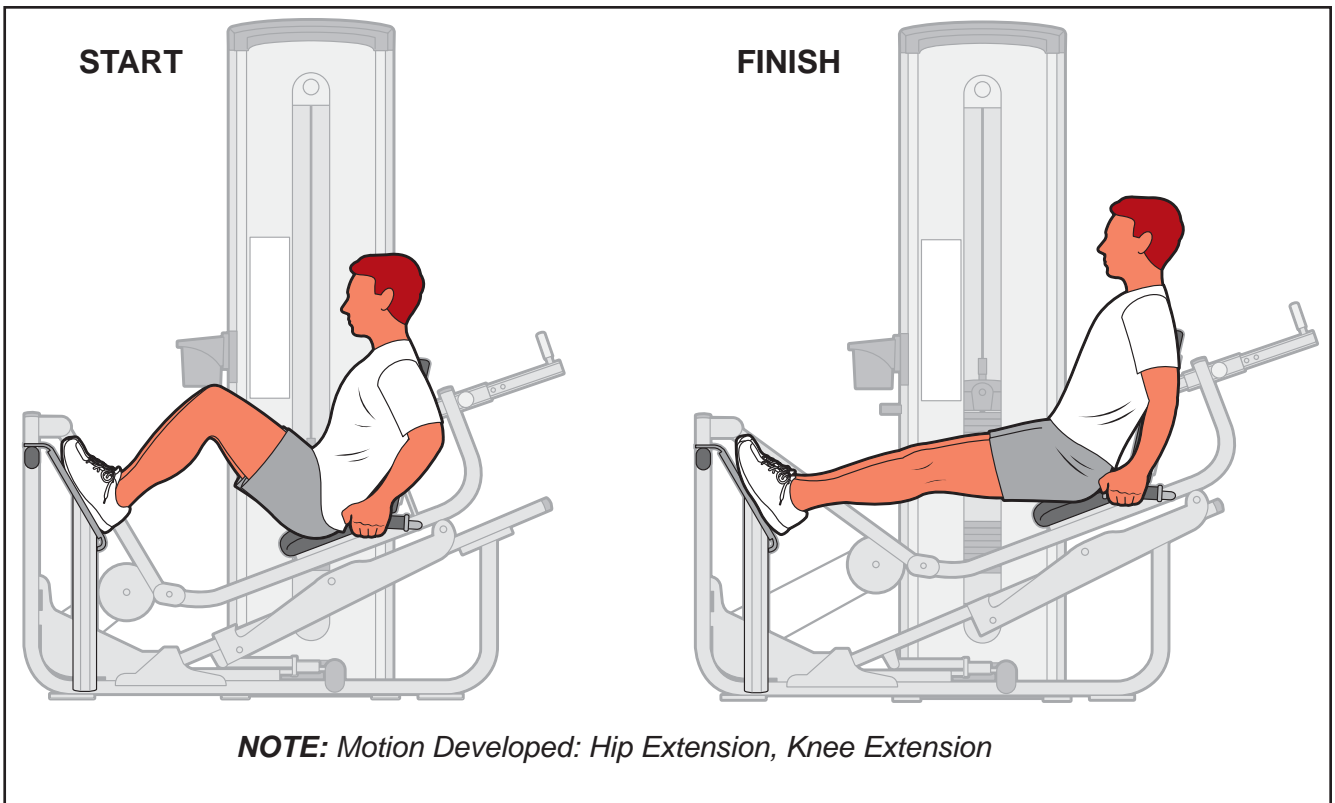

**NOTE:** All adjustment points on the machine have yellow handles or knobs.

**NOTE:** See next page for "Set Up" and "Movement."

**Set Up**

1. Adjust seat to desired start position of about 90 degrees at the knee.
2. Position feet comfortably on foot plates with toes pointed slightly outward.

**Movement**

1. Press back into back pad by extending legs.

**NOTE:** *Do not hyperextend knees.*

## 3 - Customer Service

### Contacting Service

Hours of phone service are Monday through Friday from 8:30 to 6:00 p.m. Eastern Standard Time.

For Cybex customers living in the USA, contact Cybex Customer Service at **888-462-9239**.

For Cybex customers living outside the USA, contact Cybex Customer Service at **508-533-4300** or fax **508-533-5183**.

Order parts and find information on the web at [www.eCybex.com](http://www.eCybex.com) or by e-mail at [techhelp@cybexintl.com](mailto:techhelp@cybexintl.com).

### Ordering Parts

Fax orders to **508-533-5183**. To speak with a customer service representative, call **888-462-9239** (for customers living within the USA) or **508-533-4300** (for customers outside the USA). You may also contact us through e-mail at [techhelp@cybexintl.com](mailto:techhelp@cybexintl.com)

Having the following information ready when calling will assist our Cybex representatives in serving you.

- **Unit Serial Number**
- **Product Name**

The unit serial number and product name can be found on the serial number decal. See Chapter 6 for exact location of serial number decal.

- **Part Description**
- **Part Number**

Part descriptions and part numbers are located in Chapter 6 of this manual.

- **Shipping Address**
- **Contact Name**

In addition to your shipping address and contact name, your account number is helpful but not required.

## **Return Material Authorization (RMA)**

The Return Material Authorization (RMA) system outlines the procedures to follow when returning material for placement, repair or credit. The system assures that returned materials are properly handled and analyzed. Follow the following procedures carefully.

Contact your authorized Cybex dealer on all warranty-related matters. Your local Cybex dealer will request a RMA from Cybex, if applicable. Under no circumstances will defective parts or equipment be accepted by Cybex without proper RMA and an Automated Return Service (ARS) label.

- 1. Call the Customer Service Hot Line listed above for the return of any item that is defective.**
- 2. Provide the technician with a detailed description of the problem you are having or the defect in the item you wish to return.**
- 3. Provide the model and serial number of your VR1 equipment.**
- 4. At Cybex's discretion, the technician may request that you return the problem part(s) to Cybex for evaluation and repair or replacement. The technician will assign you a RMA number and will send you an ARS label. The ARS label and the RMA numbers must be clearly displayed on the outside of the package that contains the item(s) to be returned. Include the description of the problem, the serial number of the VR1 equipment and the name and address of the owner in the package along with the part(s).**
- 5. Forward the package through UPS to Cybex.**

**Attn: Customer Service Department**

**Cybex International, Inc.**

**1975 24th Ave SW**

**Owatonna, MN 55060**

***NOTE:*** Merchandise returned without an RMA number on the outside of the package or shipments sent COD will not be accepted by the Cybex receiving department.



## Damaged Parts

Materials damaged in shipment should not be returned for credit. Shipping damages are the responsibility of the carrier (UPS, Federal Express, trucking companies, etc.)

**Apparent Damage** - Upon receipt of your shipment, check all items carefully. Any damage seen with a visual check must be noted on the freight bill and signed by the carrier's agent. Failure to do so will result in the carriers refusal to honor your damage claim. The carrier will provide you with the required forms for filing such claims.

**Concealed Damage** - Damage not seen with a visual check upon receipt of a shipment but notices later must be reported to the carrier as soon as possible. Upon discovery of the damage, a written or phone request to the carrier asking them to perform an inspection of the materials must be made within ten days of the delivery date. Keep all shipping containers and packing materials as they will be needed in the inspection process. The carrier will provide you with an inspection report and the necessary forms for filing a concealed damage claim. Concealed damage claim is the carrier's responsibility.

*This page intentionally left blank*

## 4 - Assembly

### Tools Required

- 7/32" Allen wrench
- 3/4" Socket or wrench
- Hammer
- 3/16" Pin punch

**NOTE:** Two people will be required to perform this procedure.

**NOTE:** It is the responsibility of the facility owner/owner of the equipment to ensure that there is appropriate clearance around each machine to allow for safe use and passage.

**NOTE:** Refer to Chapter 6 for reference diagrams.

**1. Read and understand all instructions thoroughly before assembling this product.**

**2. Verify you have received the appropriate configuration.**

- A. Verify that you received the correct color machine that you ordered.
- B. Verify you received the proper weight stack and weight stack decals.
- C. Verify you received the appropriate owner's manual.
- D. Verify you received the warranty sheet.

**3. Move to desired location.**

**NOTE:** If weight stacks need to be removed before moving to desired location proceed to step 7.

**NOTE:** If weight stacks need to be installed proceed to step 8.

**4. Remove shipping feet.**

***!Warning: Use extreme caution when removing shipping cones and installing feet. Failure to do so could result in injury.***

- A. With an assistant, carefully remove each (standard) cone-shaped shipping support using a 3/4" socket or wrench.
- B. Carefully place rubber feet (supplied with machine) on each foot of the frame.

**NOTE:** It is important that you perform regular inspection and maintenance activities on your equipment. See the CYBEX VR1 Owner's Manual for inspection and maintenance activities. If you do not have a CYBEX Owner's Manual or if you have any questions or concerns, Call Cybex Customer Relations at 888-462-9239.

5. Securely anchor machine to the floor.

- A. Securely anchor machine to the floor using the anchor holes provided in each machine.

**NOTE:** Cybox is not responsible for the actual anchoring of equipment. Consult with a professional contractor.

**NOTE:** Use fasteners having a minimum of 500 lbs tensil capacity (3/8" grade 2 bolts or better).

**NOTE:** If legs/frame does not contact surface, **DO NOT** pull down with anchors. Shim any leg or frame not in contact with surface using flat washers.

6. Verify proper operation.

7. Removing weight plates.

- A. Using a 7/32" Allen wrench, remove the two Button Head Socket Cap Screws (BHSCS) securing the top cap to the frame. See Figure 1.

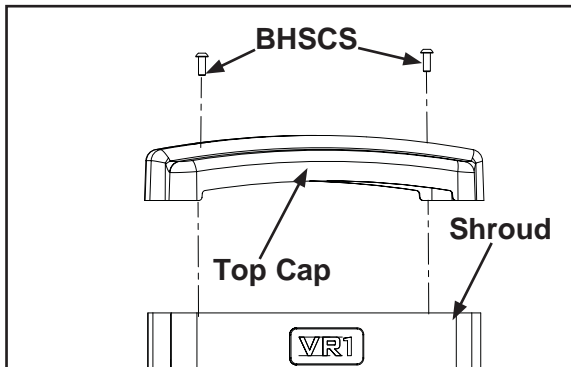

Figure 1

- B. Remove top cap and BHSCS and set aside.
- C. Carefully lift shroud up and out of machine.
- D. Slide spring loaded guide rod cap down guide rod until cap is clear of frame. **NOTE:** Guide rod cap is spring loaded.

- E. Slowly release grasp of guide rod cap. See Figure 2. **NOTE:** Guide rod cap contains a compression spring that will fly if grasp is not released slowly.

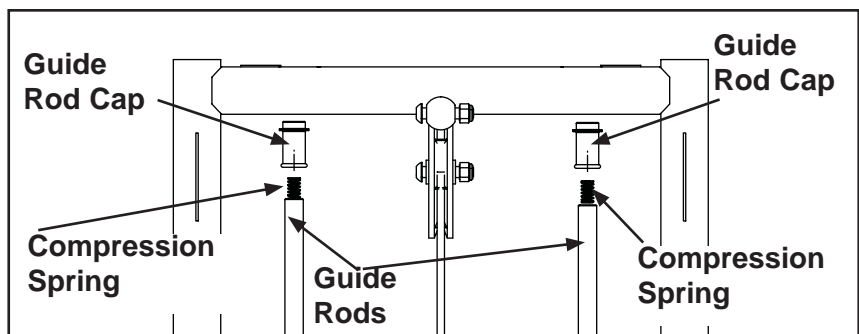

Figure 2

- F. Remove guide rod cap and spring and set aside.
- G. Repeat steps 7D - 7F for other guide rod.
- H. Using a 3/16" pin punch and hammer, carefully remove roll pin securing cable end to top weight connector. See Figure 3.
- I. Carefully lean guide rods slightly outward. **NOTE:** Excessive pressure on guide rods may damage lower guide rod caps.

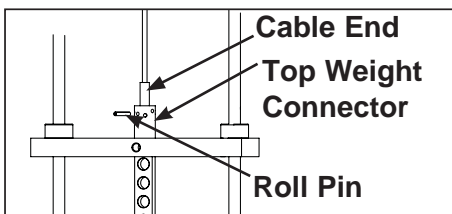

Figure 3

- J. Slide top weight up and out of machine and carefully set aside.
- K. Have an assistant hold guide rods vertical.
- L. Carefully remove each weight plate and set aside.
- M. Wipe guide rods clean over entire length. Lubricate with light coating of medium weight automotive engine oil.

### 8. Installing weight plates.

- A. Have an assistant hold guide rods vertical.
- B. Carefully align weight plates (removed in step 7M) over guide rods and slowly lower each weight plate. **NOTE:** Install weight plates in reverse order as removed in step 7M. **NOTE:** When installing weight plates, position plates so wide edges of bushings face upward and narrow edges of bushings face downward. See Figures 4A and 4B.

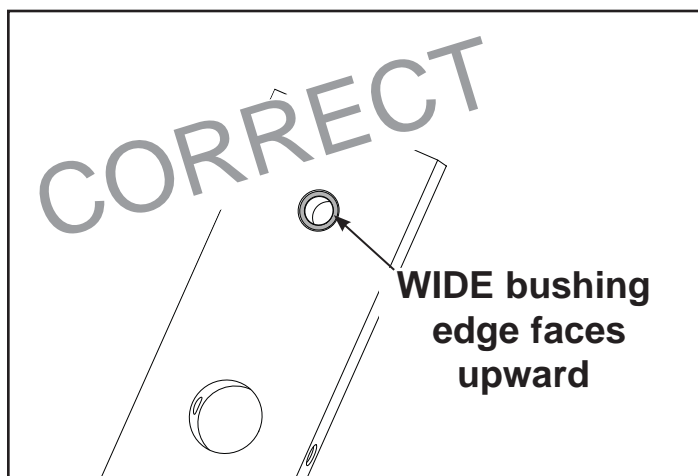

Figure 4A

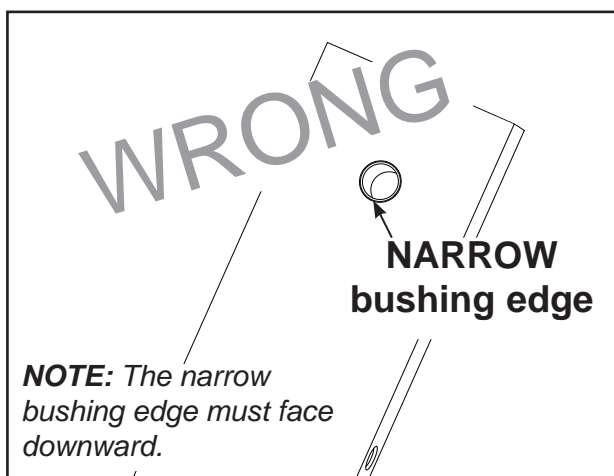

Figure 4B

- C. Repeat steps 8A and 8B for each weight plate.
- D. Carefully slide top weight (removed in step 7J) over guide rods.

**9. Cable routing.**

- A. Verify cable is routed through top of pulley bracket and then route cable end to top weight connector.
- B. Pull cable tight and secure in place with roll pin removed in step 7H.
- C. Place weight stack pin in each plate to verify proper installation.
- D. Without selecting any resistance, lift top weight up and down (simulating normal operation).
- E. Have an assistant verify that the cable is moving smoothly and is routed straight from the pulley bracket to the top of the weight plate connector.

**10. Install back shroud.**

- A. Carefully place shroud into position.
- B. Secure top cap in place with the two BHSCS removed in step 7A.

**11. Complete Steps 4 and 5.**

## 5 - Maintenance

All preventive maintenance activities must be performed on a regular basis. Performing routine preventive maintenance actions can aid in providing safe, trouble-free operation of all Cybox Strength Systems equipment.

**NOTE:** *Cybox is not responsible for performing regular inspection and maintenance actions for your machines. Instruct all personnel in equipment inspection and maintenance actions and also in accident reporting/recording. Cybox phone representatives are available to answer any questions or concerns that you may have.*



**NOTE:** *All inspections and repairs must be performed by trained service personnel only.*

**Cybox will void warranty if non-Cybox replacement parts are used.**

### Daily Procedures

- 1. Upholstery** - Wipe down all upholstery as per the recommendations listed below for light soiling and more difficult stains.

#### *Light Soiling*

- A solution of 10% household liquid soap with warm water applied with a soft damp cloth.
- If necessary, a solution of liquid cleanser and water applied with a soft bristle brush. Wipe away the residue with a water dampened cloth.

*More Difficult Stains*

- Dampen a soft white cloth with a solution of 10% household bleach (sodium hypochlorite), 90% water. Rub gently. Rinse with a water dampened cloth to remove bleach concentration.
- The same procedure can be used with full strength household bleach, if necessary.
- Allow bleach to puddle on the affected area or apply with a soaked cloth for approximately 30 minutes. Rinse with a water dampened cloth to remove any remaining bleach concentration.

*Alternative Method for Difficult Stains*

- Dampen a soft white cloth with rubbing alcohol and rub gently. Rinse with a water dampened cloth to remove any remaining rubbing alcohol concentration.

**NOTE:** *To restore luster, a light coat of spray furniture wax can be used. Apply for 30 seconds and follow with a light buffing using a clean white cloth.*

***Please Review Carefully***

When using strong cleaning agents such as rubbing alcohol or bleach, it is advisable to first test in an inconspicuous area. Other cleaning agents may contain harsh or unknown solvents and are subject to formula changes by the product manufacturer without notice. Should you desire to use other cleaning agents, carefully try them in an inconspicuous area to determine potential damage to the material. Never use harsh solvents or cleaners which are intended for industrial applications. To clean stained or soiled areas, a soft white cloth is recommended. Avoid use of paper towels.

Cleaning products may be harmful/irritating to your skin, eyes, etc. Use protective gloves and eye protection. Do not inhale or swallow any cleaning product. Protect surrounding area/clothing from exposure. Use in well ventilated area. Follow all product manufacturer's warnings. CYBEX and its vendors cannot be held responsible for damage or injuries resulting from the use or misuse of cleaning products.

**2. Frames** - Wipe down all frames using a mild solution of warm water and car wash soap. Be sure to dry thoroughly. **AVOID** acid or chlorine based cleaners and also cleaners containing abrasives as these could scratch or damage the equipment.

**3. Chrome** - Clean chrome tubes, first using chrome polish and then using a car wax seal. Neutral cleaners with a pH between 5.5 and 8.5 are recommended. Be sure to dry thoroughly. **AVOID** acid or chlorine based cleaners and also cleaners containing abrasives as these could scratch or damage the equipment.



**4. Guidelines for cleaning front panel:**

- Use clean soft cloths or sponges for application of cleaners and again for washing and rinsing.
- Follow up the application with warm water rinse.
- Don't use abrasives or high alkaline cleaners.
- Don't leave cleaners on for long periods, wash immediately.
- Don't apply cleaners in direct sunlight or at elevated temperatures.
- Don't use scrapers, squeegees or razors.
- Don't clean with gasoline.

**Compatible Cleaners and Detergents:**

- Formula 409
- Top Job
- Joy
- Palmolive
- Windex with Ammonia D

**To Minimize Fine or Hairline Scratches:**

Mild automotive polish applied and removed with a soft, clean cloth will help fill scratches.

**Suggested Polishes:**

- Johnson Past Wax
- Mirror Glaze #10 Plastic Polish (by Mirror Bright Polish Co.)
- Novus Plastics Polish #1, #2 (By Novus Inc.)

## Weekly Procedures

1. Check all nuts and bolts for looseness. Tighten as required.
2. Inspect all cables for wear or damage and proper tension. When inspecting cables, run fingers on the cable, paying particular attention to bends in cable and attachment points.

**WARNING: Replace all worn cables immediately. The following conditions may indicate a worn cable:**

- A tear or crack in the cable sheath that exposes the cable. See Figure 1.

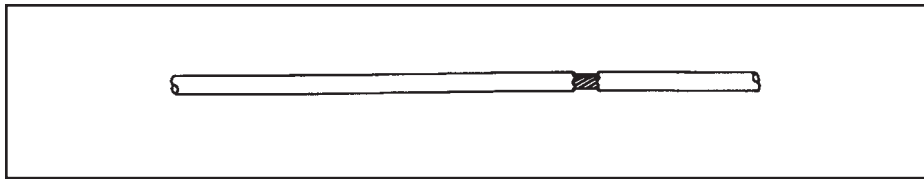

Figure 1.

- A kink in the cable. See Figure 2.

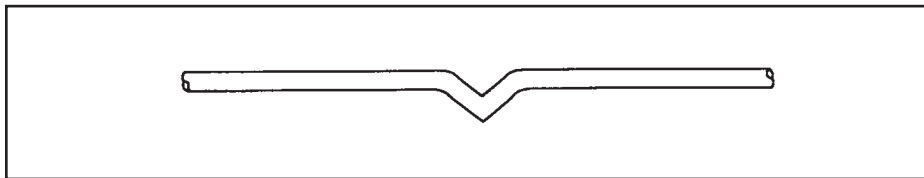

Figure 2.

- A curled sheath. See Figure 3.

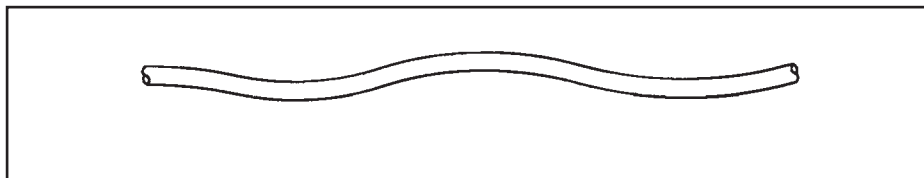

Figure 3.

- "Necking", a stretched cable sheath. See Figure 4.

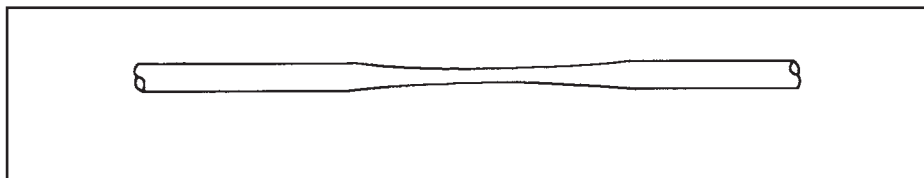

Figure 4.

3. Inspect bars and handles for wear, paying particular attention to tab area connection points.

**Replace all worn handles immediately.**

***!CAUTION: Replace all worn handles immediately. Do not use if less than 1/8" of material remains to the edge. See Figure 5.***

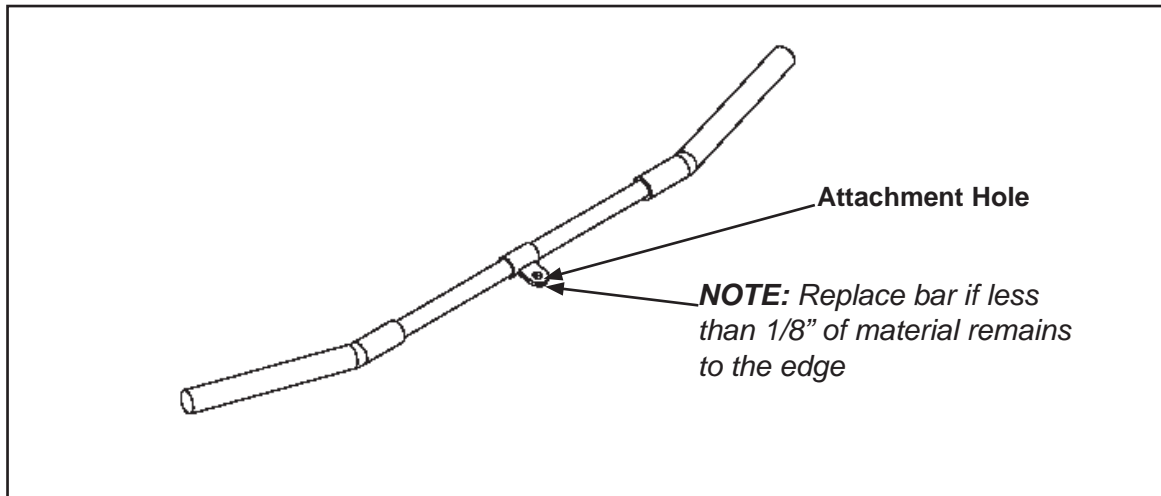

Figure 5

4. Inspect snap links for proper latching (indicates wear)

**Replace all worn snap links immediately.**

5. Inspect for loose or worn grips.

**Replace all loose or worn grips immediately.**

6. Inspect all labeling for readability. This includes instructional placards, warning and caution decals.

**Replace all worn labeling immediately.**

7. Inspect all weight stacks for proper alignment and operation.

**Correct all improper alignment and operation issues immediately.**

8. Wipe Weight Stack Guide Rods clean over entire length. Lubricate with a light coat of medium weight automotive engine oil.

## Yearly Procedures

1. Replace all cables at least annually.

## Cable Adjustment

Three types of cable tension adjustment are used on Cybox Strength Systems:

- 1. Jam Nut Adjustment** - This type uses a jam nut and a tension adjustment nut at the cable cam end as the primary adjustment. The other end of the cable usually contains a roll pin adjustment. See Figures 6 and 7.
- 2. Rod End Adjustment** - This type of adjustment contains a socket head cap screw (SHCS) securing a cable rod end bearing to the machine. Primary adjustment is by turning the rod end bearing. The other end of the cable usually contains a roll pin cable adjustment. See Figures 7 and 8.
- 3. Roll Pin Adjustment** - This type of adjustment utilizes a roll pin and series of holes in the weight stack top weight connector. See Figure 8.

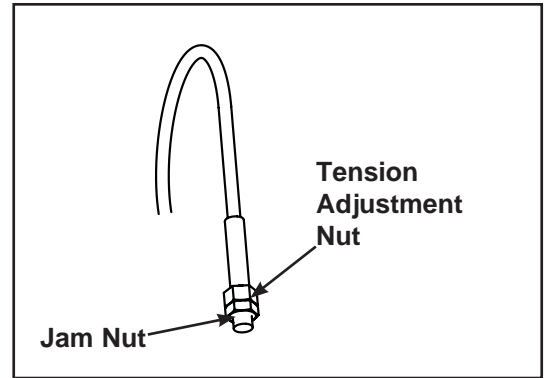

Figure 6

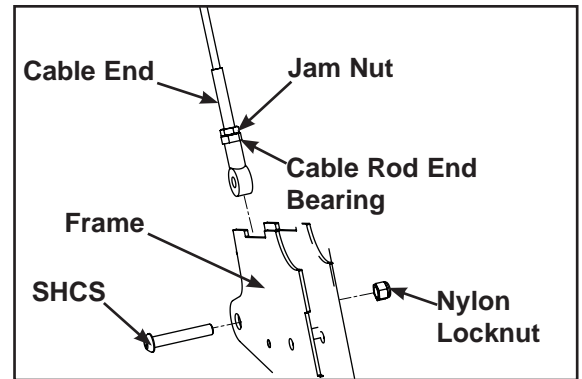

Figure 7

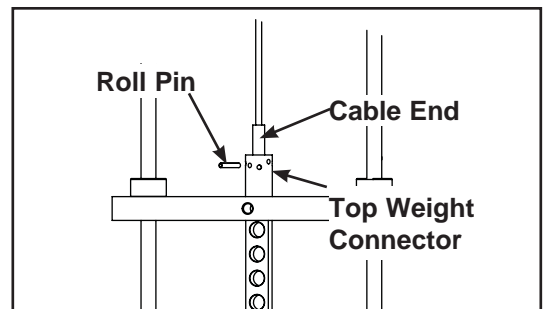

Figure 8

## Environment

**Static Electricity** - Depending upon where you live, you may experience dry air, causing a common experience of static electricity. This may be especially true in the winter time. You may notice a static build-up just by walking across a carpet and then touching a metal object. The same can hold true while working out on your unit. You may experience a shock due to the build-up of static electricity on your body and the discharge path of the unit. If you experience this type of situation, you may want to increase the humidity to a comfortable level through the use of a humidifier.

**Humidity** - The unit is designed to function normally in an environment with a relative humidity range of 30% to 75%.

**NOTE:** *Do not install or use the unit in an area of high humidity, such as in the vicinity of a steam room, sauna, indoor pool or outdoors. Exposure to extensive water vapor, chlorine and/or bromine could adversely affect the electronics as well as other parts of the machine.*

**Temperature** - The unit is designed to function normally in an environment with an ambient temperature range of 50° F (10° C) to 104° F(40° C) degrees.

## Storage

**Humidity** - The unit can be shipped and stored in an environment with a relative humidity range of 10% to 90%.

**NOTE:** *Do not store the unit in an area of high humidity, such as in the vicinity of a steam room, sauna, indoor pool or outdoors. Exposure to extensive water vapor, chlorine and/or bromine could adversely affect the electronics as well as other parts of the machine.*

**Temperature** - The unit can be shipped and stored in an environment with an ambient temperature range of 32° F (0° C) and 140 F (60° C) degrees.

*This page intentionally left blank.*

## 6 - Service

Please refer to the next several pages for parts lists, exploded-view diagrams and cable and belt routing diagrams.



***NOTE:** All inspections and repairs must be performed by trained service personnel only.*

Cybex will void warranty if non-Cybex replacement parts are used.

*This page intentionally left blank.*



# LEG PRESS

PRODUCT NO. 13040

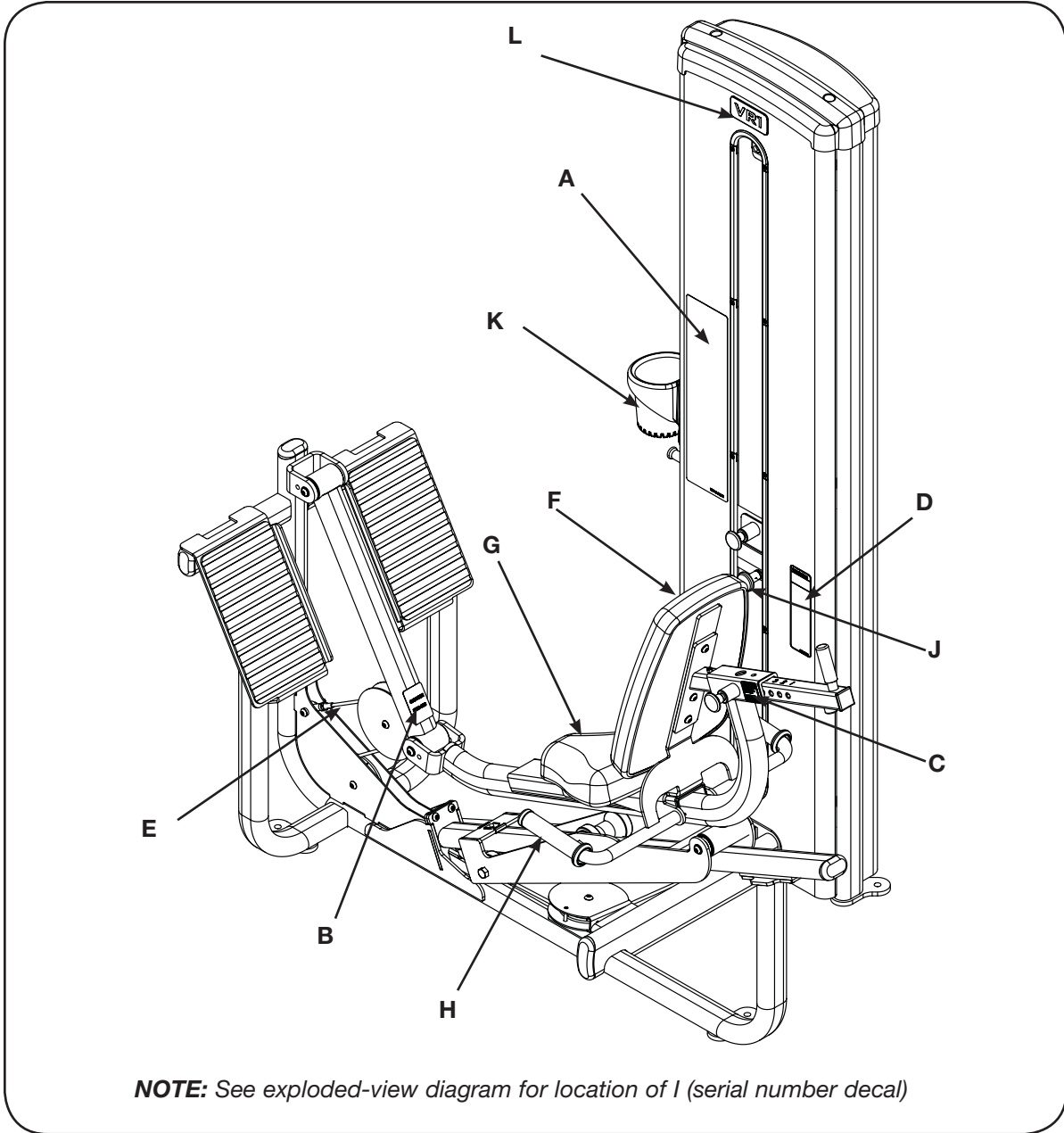

**NOTE:** See exploded-view diagram for location of I (serial number decal)

DESCRIPTION	PART NO.	DESCRIPTION	PART NO.
A. Placard Decal .....	13040-598	G. Seat Pad .....	4800-164
B. Caution Decal .....	8500-026	H. Grip .....	4605-500
C. Caution Decal .....	8500-025	I. Serial Number Decal	
D. Warning Label .....	4605-381	J. Weight Selector Pin.....	BH030207
E. Cable.....	13040-002	K. Water Bottle Holder.....	13000-400
F. Back Pad.....	4800-176	L. VR1 Decal.....	13000-399

**Cybex VR1 Owner's Manual**

ITEM	QTY	PART NO.	DESCRIPTION
1	5	08014	PULLEY ASSEMBLY, 4.50 IN.
2	1	11040-440	KNOB
3	2	11040-572	GUARD, INCREMENT WEIGHT
4	2	11080-337	SHAFT PIVOT
5	2	11090-374	END CAP
6	2	11090-376	RING, HANDLE GRIP
7	1	11090-385	GRIP
8	2	12210-347	GUIDE ROD CAP
9	2	12210-348	GUIDE ROD CAP
10	2	13000-322	ROLLER
11	1	13000-342	MOLDED TOP CAP
12	4	13000-353	FOOT PAD
13	1	13000-354	FOOT PAD (NOT SHOWN)
14	1	13000-355	FOOT PAD
15	2	13000-364	BEARING, FLANGE .62 ID. x .92 OD. x 1.75 LG
16	1	13000-400	HOLDER, WATER BOTTLE
17	1	13000-403	MOUNT, WATER BOTTLE HOLDER
18	1	13040-002	CABLE S/A
19	2	13040-005	ROLLER ASSEMBLY
20	1	13040-200	W/FRAME
21	1	13040-201	W/CARRIAGE
22	1	13040-203	P/GUIDE TUBE
23	1	13040-204	W/LINK BAR
24	1	13040-205	SEAT
25	1	13040-206	P/DETENT TUBE
26	1	13040-207	PIVOT
27	1	13040-328	GUIDE CHANNEL
28	2	13040-335	NON-SLIP
29	2	13040-336	WT ROD .625 DIA X 66.43
30	1	13040-337	PIVOT SHAFT
31	1	13040-338	HANDLE SHAFT
32	1	3900-438	DECAL, CYBEX
33	1	4505-329	P/PIN,DETENT
34	1	4605-511	INSERT,PLASTIC 5.94
35	1	4700C066	TOP WT 20 - 3 x 12
36	1	51198	WARRANTY BOOK (NOT SHOWN)
37	2	8630-340	SPACER
38	1	BH030207	PIN, WEIGHT SELECTOR
39	2	BR030206	RING, RETAINING
40	2	BR030220	RETAINING RING 1.250 INTERNAL
41	1	BS070201	COM SPRING .56 x .66 1.50 LG
42	2	BS070208	COMPRESSION SPRING
43	1	CM000211	DECAL, PATENT PENDING
44	1	FB030213	ROD END BEARING FEMALE .375-24 UNF
45	6	FB030232	BEARING, RADIAL 17 mm EXTENDED RACE
46	4	FB030240	BEARING, TAPPERED ROLLER
47	10	FC030006	TOLERANCE RING 1.575 ID
48	4	GP000215	SHOULDER ADAPTER
49	1	HC620431	BHSCS .250-20 X 2.00
50	1	HC700414	BHSCS .375-16 X .625
51	2	HC700415	BHSCS .375-16 X .75

ITEM	QTY	PART NO.	DESCRIPTION
52	5	HC700417	BHSCS .375-16 X 1.00
53	2	HC700426	BHSCS .375-16 X 2.00
54	1	HC700428	BHSCS .375-16 X 2.25
55	2	HC781254	HX HD CAP SC .500-13 UNC X 5.50
56	2	HF449063	INSERT 3/4 X 1/4-20
57	2	HF700000	PANEL FASTNER, .375-16 , U TYPE
58	2	HN625200	LOCKNUT, .250-20 NYLON
59	11	HN704901	LOCKNUT, .375-16 NYLON
60	2	HN784901	NYLON LOCKNUT .500-13 THIN
61	1	HP286819	SPIRAL PIN .188 X 1.12
62	7	HS347600	WASHER, SAE .375
63	2	HS720004	WASH, FELT .641 1.250 .125T
64	2	HT512517	TAP SC 10-24 X 1.00 TYPE WB PN HD PHIL BLK
65	1	HT552515	TAP SC NO. 8-16 X .75 PLASTITE PN HD PHIL BLK
66	1	JC620415	BHSCS .250-20 X .75
67	2	JC620422	BHSCS .250-20 x 1.50
68	7	JC700412	BHSCS .375-16 X .50
69	2	JC700420	BHSCS .375-16 X 1.25
70	2	JC700422	BHSCS .375-16 X 1.50
71	5	JC700424	BHSCS .375-16 X 1.75
72	1	JN714400	NUT, HEX JAM .375-24 UNF
73	5	JS347400	LOCKWASHER, INT TOOTH .375
74	1	PN660200	INSERT, PLASTIC 1.00 DIA-11 GA
75	1	PP090211	INSERT, PL 1.50 SQ X 10-14 GA
76	1	PP130002	INSERT, DOMED PLASTIC
77	4	PP130003	INSERT, DOMED PLASTIC
78	1	PR060003	BUMPER, RECESS
79	2	PR060005	BUMPER, WEIGHT
80	2	PR069400	BUMPER, RECESS
81	2	4605-500	GRIP 1.38 OD X .94 ID 6 INCHES
82	1	4800-176	BACK PAD
83	1	4800-164	SEAT PAD
84	1	8500-026-X*	CAUTION DECAL
85	1	8500-025-X*	CAUTION DECAL
86	1	13000-399	VR1 DECAL
87	1	13040-100	EDGE TRIM
88	1	13040-598-X*	PLACARD
89	1	13040-322	FRONT PANEL
90	1	13040-324	BACK PANEL
91	1	13000-208	LATCH
92	1	13000-101	5 LB OPTIONAL HALF WEIGHT
92	1	13000-102	7.5 LB OPTIONAL HALF WEIGHT
93	10	HT552511	TAP SC 16 X .38 BLACK
94	1	13040-999-X*	OWNERS MANUAL (NOT SHOWN)
95	1	4605-381-X*	WARNING DECAL
96	19	13000-033	WEIGHT PLATE PACK (LIGHT)
97	19	13000-037	WEIGHT PLATE PACK (STANDARD)
98	1	4700-337	WEIGHT PLATE (LIGHT)
99	1	4700-338	WEIGHT PLATE (STANDARD)
100	1	4800-557	DECAL, WEIGHT PLATE (10-150)
101	1	13000-551	DECAL, WEIGHT PLATE (160-200)
102	1	13000-552	DECAL, WEIGHT PLATE (10-220)
103	1	13000-553	DECAL, WEIGHT PLATE (235-295)

**\*Language Key**

- 1- German
- 2- French
- 3- Spanish
- 4- English
- 6- Japanese
- 7- Swedish
- 8- Russian

LEG PRESS MAIN ASSEMBLY DETAIL

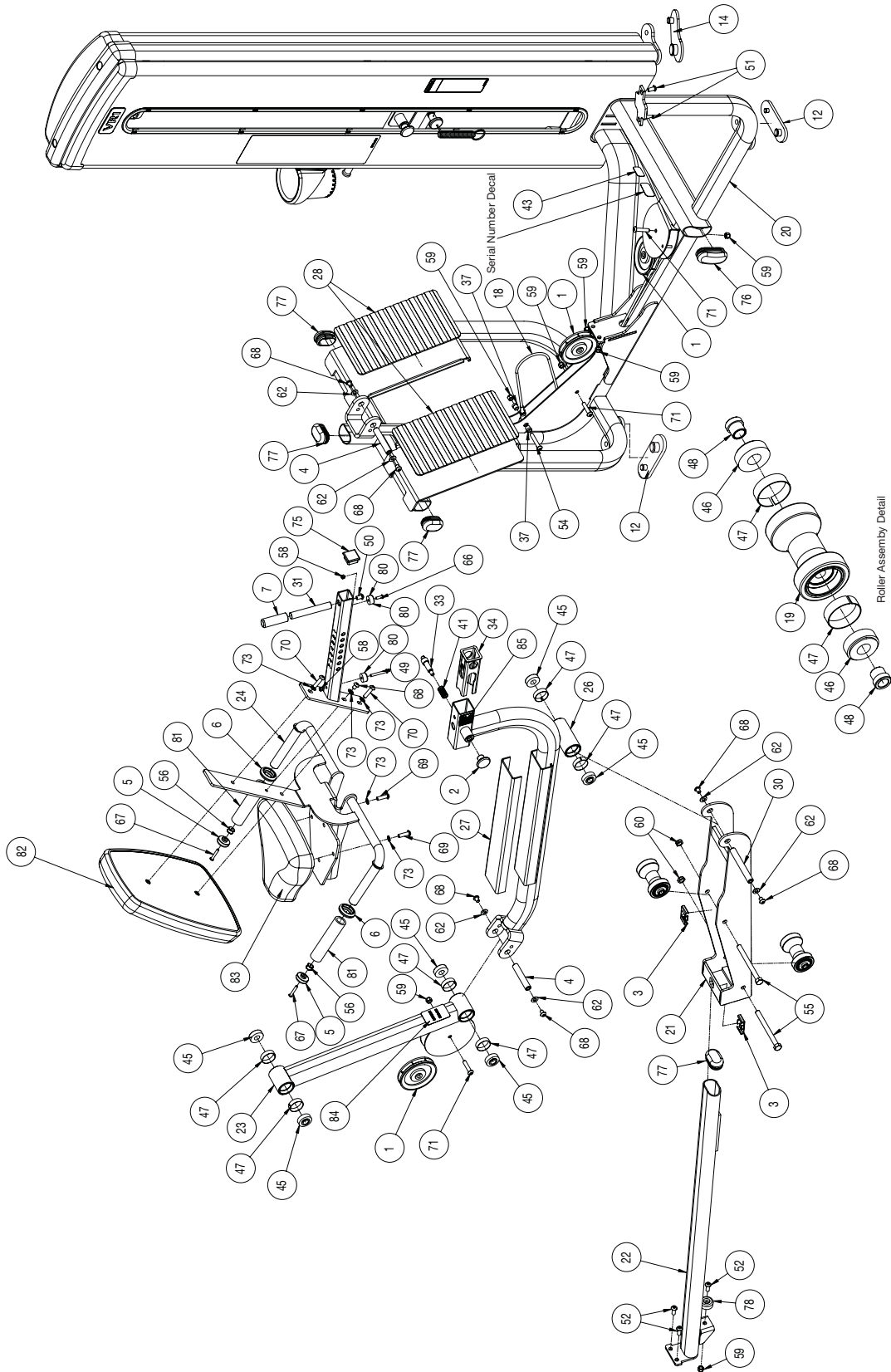



### LEG PRESS CABLE ASSEMBLY DETAIL

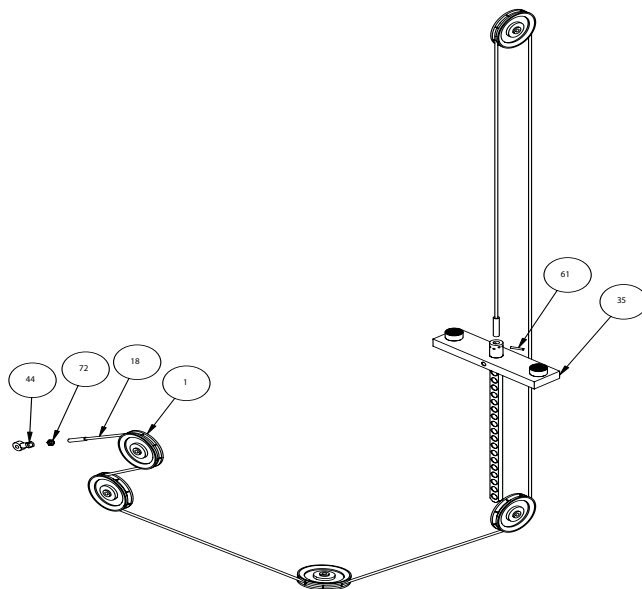
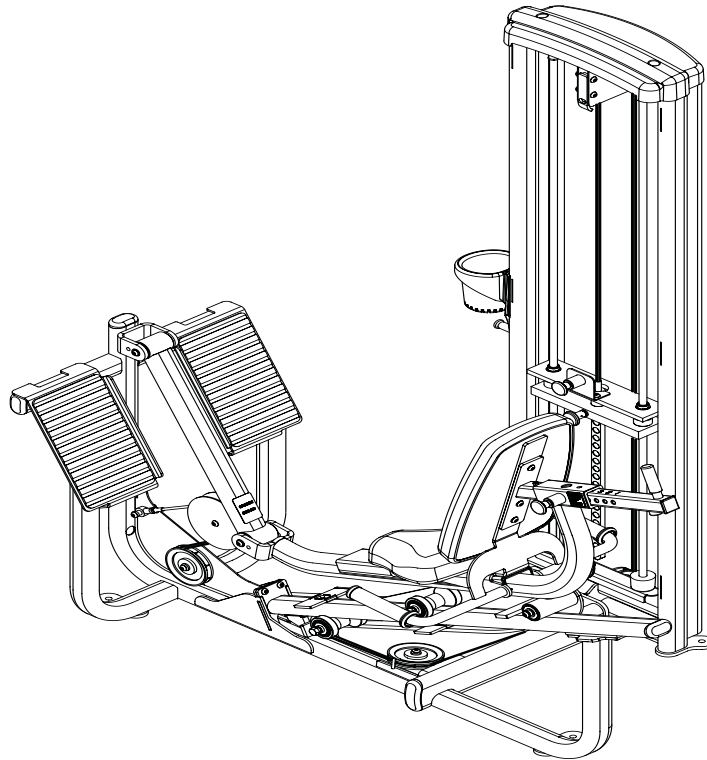







10 Trotter Drive Medway, MA 02053 • 508-533-4300 • FAX 508-533-5183  
www.cybexinternational.com • Techhelp@cybexintl.com•techpubs@cybexintl.com