

Row HX Trainer

HXD-ALLLX-101, HXL-ALLLX-101

Owner's Manual



Corporate Headquarters

10601 W Belmont Ave, Franklin Park, IL 60131 • U.S.A.
847.288.3300 • FAX: 847.288.3703
Service phone number: 800.351.3737 (toll-free within U.S.A., Canada)
Global Website: www.lifefitness.com

International Offices

AMERICAS

North America

Life Fitness, LLC

10601 W Belmont Ave
Franklin Park, IL 60131 U.S.A.
Telephone: (847) 288 3300
Service Email:
customersupport@lifefitness.com
Sales/Marketing Email:
consumerproducts@lifefitness.com

Brazil

Life Fitness Brasil

Av. Rebouças, 2315
Pinheiros
São Paulo, SP 05401-300
BRAZIL
SAC: 0800 773 8282 option 2
Telephone: +55 (11) 3095 5200 option 2
Service Email: suportebr@lifefitness.com
Sales/Marketing Email:
vendasbr@lifefitness.com

Latin America and Caribbean*

Life Fitness, LLC

10601 W Belmont Ave
Franklin Park, IL 60131 U.S.A.
Telephone: (847) 288 3300
Service Email:
customersupport@lifefitness.com
Sales/Marketing Email:
consumerproducts@lifefitness.com

EUROPE, MIDDLE EAST, and AFRICA (EMEA)

Netherlands and Luxemburg

Life Fitness Atlantic BV

Bijdorplein 25-31
2992 LB Barendrecht
THE NETHERLANDS
Telephone: (+31) 180 646 666
Service Email:
service.benelux@lifefitness.com
Sales/Marketing Email:
marketing.benelux@lifefitness.com

United Kingdom

Life Fitness UK LTD

Queen Adelaide
Ely, Cambs, CB7 4UB
Telephone: General Office (+44)
1353.666017
Customer Support (+44) 1353.665507
Service Email: uk.support@lifefitness.com
Sales/Marketing Email: life@lifefitness.com

Germany, Austria, and Switzerland

Life Fitness Europe GMBH

Neuhofweg 9
85716 Unterschleißheim
GERMANY
Telephone:
+49 (0) 89 / 31775166 Germany
+43 (0) 1 / 6157198 Austria
+41 (0) 848 / 000901 Switzerland
Service Email:
kundendienst@lifefitness.com
Sales/Marketing Email:
vertrieb@lifefitness.com

Spain

Life Fitness IBERIA

C/Frederic Mompou 5,1ª^a
08960 Sant Just Desvern Barcelona
SPAIN
Telephone: (+34) 93.672.4660
Service Email:
servicio.tecnico@lifefitness.com
Sales/Marketing Email:
info.iberia@lifefitness.com

Belgium

Life Fitness Benelux NV

Parc Industriel de Petit-Rechain
4800 Verviers
BELGIUM
Telephone: (+32) 87 300 942
Service Email:
service.benelux@lifefitness.com
Sales/Marketing Email:
marketing.benelux@lifefitness.com

All Other EMEA Countries and Distributor Business EMEA*

Life Fitness Atlantic BV

Bijdorplein 25-31
2992 LB Barendrecht
THE NETHERLANDS
Telephone: (+31) 180 646 644
Service Email:
EMEAServiceSupport@lifefitness.com

ASIA PACIFIC (AP)

Japan

Life Fitness Japan, Ltd

4-17-33 Minami Aoyama 1F/B1F
Minato-ku - Tokyo 107-0062
Japan
Telephone: (+81) 0120.114.482
Fax: (+81) 03-5770-5059
Service Email: service.lfj@lifefitness.com
Sales/Marketing Email:
sales@lifefitnessjapan.com

Hong Kong

Life Fitness Asia Pacific LTD

32/F, Global Trade Square
21 Wong Chuk Hang Road
Hong Kong
Telephone: (+852) 2575.6262
Service Email: Service.HK@lifefitness.com
Sales/Marketing Email:
hongkong.sales@lifefitness.com

All Other Asia Pacific countries and distributor business Asia Pacific*

Life Fitness Asia Pacific LTD

32/F, Global Trade Square
21 Wong Chuk Hang Road
Hong Kong
Telephone: (+852) 2575.6262
Fax: (+852) 2575.6894
Service Email: Service.AP@lifefitness.com
Sales/Marketing Email:
Marketing.HK.Asia@lifefitness.com

*Also check www.lifefitness.com for local representation or distributor/dealer

User and Service Documents Link

<https://lifefitness9512.zendesk.com/hc/en-us>

<https://www.lftechsupport.com/web/document-library/documents>

Additional information is available online using the links above.

تتوفر معلومات إضافية على الإنترنت باستخدام الرابط أعلاه.

点击上面的链接可在线获取更多信息。

Flere oplysninger er tilgængelige online gennem linket ovenfor.

Bijkomende informatie is online beschikbaar via bovenstaande link.

Vous trouverez plus d'informations en ligne à l'aide du lien ci-dessus.

Zusätzliche Informationen finden Sie online über den oben angegebenen Link.

Ulteriori informazioni sono disponibili online utilizzando il link sopra riportato.

追加情報は上記リンクを使用してオンラインで利用可能です。

상기 링크를 통해 온라인에서 추가 정보를 볼 수 있습니다.

Informações adicionais estão disponíveis on-line, através do link acima.

Дополнительная информация доступна в интернете по ссылке, указанной выше.

Mediante el enlace anterior podrá acceder a información adicional en línea.

Ytterligare information finns online genom att använda länken ovan.

İnternet üzerinden daha fazla bilgi edinmek için yukarıdaki bağlantıyı kullanabilirsiniz.

هناك معلومات إضافية متاحة على الإنترنت باستخدام الرابط أعلاه.

Informazio osagarria eskuragarri dago goiko estekaren bidez.

Допълнителна информация можете да намерите онлайн, като използвате връзката по-горе.

Mitjançant l'enllaç anterior podreu accedir a informació addicional en línia.

使用上面的連結線上提供額外資訊。

Dodatne informacije možete pronaći na internetu sljedeći vezu iznad.

ከላይ የተመጠውን አገናኝ(ሊንክ) በመጠቀም መረጃዎች አንላይን ያገኛሉ።

Lisätietoja on saatavissa verkosta käyttämällä yllä olevaa linkkiä.

Wubetumi anya nsem afoforo aka ho wa websait so denam asem a ewa atifi ho a wubemia so so.

Πρόσθετες πληροφορίες είναι διαθέσιμες online χρησιμοποιώντας το σύνδεσμο παραπάνω.

מידע נוסף אפשר לקבל באינטרנט באמצעות הקישור לעיל.

További információ elérhető online, a fenti hivatkozás segítségével.

Viðbótarupplýsingar eru fáanlegar á netinu með því að smella á tengilinn hér fyrir ofan.

Plus indicium per superum situm potes invenire.

മുകളിലുള്ള ലിങ്ക് ഉപയോഗിച്ച് ഓൺലൈനിൽ കൂടുതൽ വിവരങ്ങൾ ലഭ്യമാണ്.

Ytterligere informasjon er tilgjengelig på nettet via linken ovenfor.

Dodatkowe informacje są dostępne online pod powyższym odnośnikiem.

Informações adicionais estão disponíveis online a usar o link acima.

Informații suplimentare sunt disponibile online, utilizând link-ul de mai sus.

Dodatne informacije dostupne su na mreži putem gornjeg linka.

Ďalšie informácie sú dostupné online na vyššie uvedenom odkaze.

Table of Contents

Safety

Safety Instructions.....	4
--------------------------	---

Getting Started

Specifications - Row HX Trainer.....	6
Tank Filling.....	7

Operation

Computer Instructions with Bluetooth.....	9
Auto Start.....	9
Calibration Procedure.....	10
Resistance.....	11
Slider Footplate.....	11
How to Row.....	13
How Often.....	13

Maintenance

Service Schedule.....	14
Water Treatment Procedure.....	14
Long Term Water Treatment.....	14
Vertical Storage (Not Available in All Areas).....	14
Optional Storage (Not Available in All Areas).....	15

Troubleshooting







Console.....	16
Mechanical.....	16
Console Firmware Update.....	17

Warranty

What is Covered.....	18
Who is Covered.....	18
How Long is it Covered.....	18
Who Pays Shipping and Insurance for Service.....	18
What We Will Do To Correct Covered Defects.....	18
What is Not Covered.....	18
What You Must Do.....	18
User Manual.....	18
Product Registration.....	18
How to Get Parts and Service.....	18
Exclusive Warranty.....	19
Changes in Warranty Not Authorized.....	19
Effects of State Laws.....	19

1. Safety

Safety Instructions

-  **WARNING:** Heart rate monitoring systems may be inaccurate. Over exercising may result in serious injury or death. If you feel faint, stop exercising immediately.
-  **WARNING:** Do not insert fingers into tank!
-  **WARNING:** Never operate this rower without feet properly secured in Foot straps, or without the sliding portion of the Slider Footplate locked into position!
-  **CAUTION:** Do not fill past the calibration mark as indicated on the tank level sticker or water spillage can occur.
-  **CAUTION:** The rower can stand vertically for storage. Please allow the unit to sit for 5 minutes before standing it up for storage. Please follow the instructions given in the Basic Operation section of this manual.
-  **CAUTION:** After rowing exercise, please allow unit to sit for 5 minutes before standing up

- Before using this product, it is essential to read this ENTIRE operation manual and ALL instructions. This product is intended for use solely in the manner described in this manual.
- UNDERSTANDING EACH AND EVERY WARNING TO THE FULLEST IS IMPORTANT. IF ANY OF THESE WARNINGS ARE UNCLEAR, CONTACT Life Fitness Family of Brands CUSTOMER SERVICE IMMEDIATELY AT .
- This equipment is categorized as class HC per EN ISO 20957-1. As such this equipment is only intended for home use only. It is not intended for commercial, institutional and/or studio facilities. Contact Life Fitness with any questions regarding this classification.
- It is recommended that all users of Life Fitness Family of Brands exercise equipment be informed of the following information prior to use.
- As with any piece of fitness equipment, consult a physician before beginning your exercise program.
- Please be aware that any fitness regiment, before being undertaken, is best preceded by a physical checkup from a certified physician.
- Injuries to health may result from incorrect or excessive training.
- Stop the machine immediately if any signs of excessive wearing are present on the belts, pulleys and bungee cords. Do not use unit until said parts are repaired or replaced.
- Do not allow children under 14 years of age unattended access to the machine.
- Please keep hands away from moving parts, as indicated by the warning label on the mainframe of your machine.
- If any of the adjustment devices are left projecting, they could interfere with the user's movement.
- Do not store in freezing conditions with water in the tank as it can expand and crack the components.
- This fitness equipment is not intended for use by persons (including children) with reduced physical, sensory or mental capabilities, or lack of experience and knowledge, unless they have been given supervision or instruction concerning use of the equipment by a person responsible for their safety.
- Place on a stable, flat surface in a horizontal position during use for maximum stability.
- Check all belts, pulleys and bungee cords regularly for signs of wear, and replace if needed.
- Check regularly and follow all instructions for maintenance as specified in this manual.
- Replace immediately any defective parts and do not operate unit until all repairs are complete.
- Do not use any equipment in any way other than designed or intended by the manufacturer. It is imperative that Life Fitness equipment is used properly to avoid injury.
- Injuries may result if exercising improperly or excessively. It is recommended that all individuals consult a physician prior to commencing an exercise program. If at any time during exercise you feel faint, dizzy or experience pain, STOP EXERCISING and consult your physician.
- Keep body parts (hands, feet, hair, etc.), clothing and jewelry away from moving parts to avoid injury.
- Follow instructions provided in this manual for correct foot position and basic rowing techniques.
- For more detailed rowing techniques, please refer to our International website <http://www.lifefitness.com>.
- This equipment is not intended for use by children. Keep children under the age of 14 away from the machine.
- DO NOT use or permit use of any equipment that is damaged and/or has worn or broken parts. For all Life Fitness Family of Brands equipment use only replacement parts supplied by Life Fitness Family of Brands.
- Cables and belts pose an extreme liability if used when frayed. Always replace any cable or belt at first sign of wear (consult Life Fitness Family of Brands if uncertain).
- MAINTAIN LABELS AND NAME PLATES - Do not remove labels for any reason. They contain important information. If unreadable or missing, contact Life Fitness Family of Brands for a replacement.

- EQUIPMENT MAINTENANCE - Preventative maintenance is the key to smooth operating equipment as well as to keep your liability to a minimum. Equipment needs to be inspected at regular intervals.
- Ensure that any person(s) making adjustments or performing maintenance or repair of any kind is qualified to do so.
- DO NOT ATTEMPT TO USE OR REPAIR ANY ACCESSORY APPROVED FOR USE WITH THE LIFE FITNESS EQUIPMENT WHICH APPEARS TO BE DAMAGED OR WORN.
- It is the purchaser's sole responsibility to properly instruct its end users and supervising personnel as to the proper operating procedures of all Life Fitness Family of Brands equipment.
- Do not allow users to wear loose fitting clothing or jewelry while using equipment. It is also recommended to have users secure long hair back and up to avoid contact with moving parts.
- All bystanders must stay clear of all users, moving parts and attached accessories and components while machine is in operation.

2. Getting Started

Specifications - Row HX Trainer

Row HX Trainer is not suitable for therapeutic purposes.

Product Class	HC
Braking System	Speed Independent
Product Gross Weight	87.08 lb (32.7 kg)
Max User Weight	330 lb (150 kg)
Minimum Safe Operating Surface Area	131.09" (333 cm) Length x 67.71" (172 cm) Width
Dimensions	83.85" (213 cm) Length x 20.47" (52 cm) Width x 22.04" (56 cm) Height

The live area shall be not less than 23.62" (60 cm) greater than the training area in the directions from which the equipment is accessed. The live area must also include the area for emergency dismount.

Live area and Training area

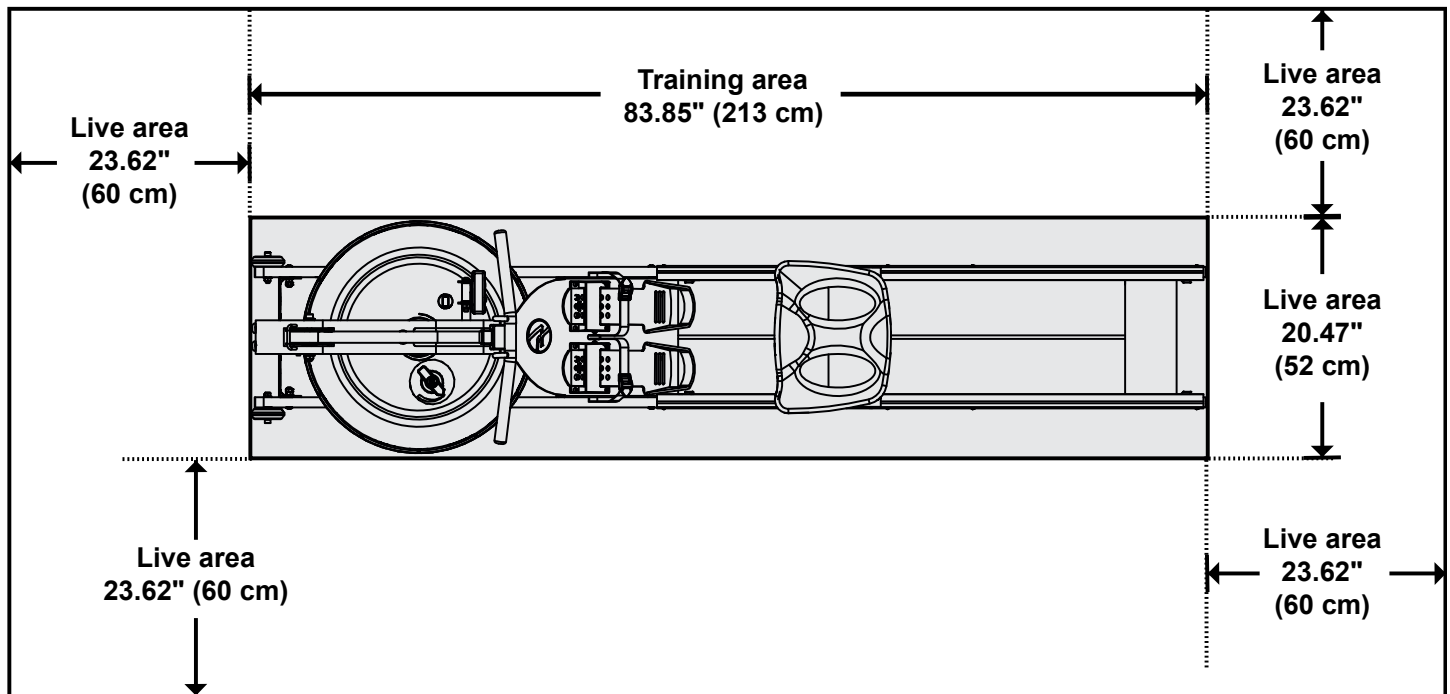

Tank Filling

Tools required:

- Siphon, included with rower
- Bucket, 5 gallons (19 liters)
- Water
- Drop cloth

NOTE: Where water quality is known to be poor, we recommend the use of distilled water.



CAUTION: Use a drop cloth under the tank when filling to avoid staining floor or carpet.

1. Turn resistance knob counter-clockwise to maximum position.

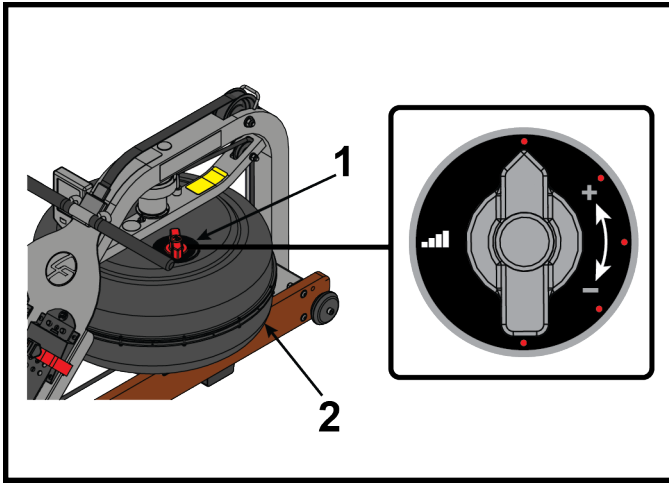

Item	Description	Qty.
1	Resistance knob	1
2	Tank	1

2. Remove cap from tank.

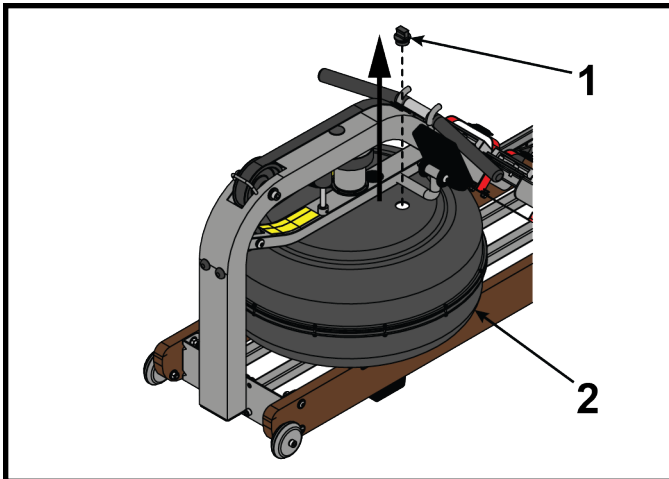

Item	Description	Qty.
1	Cap	1
2	Tank	1



WARNING: Do not insert fingers into tank!

3. Place siphon into bucket and siphon hose into tank.

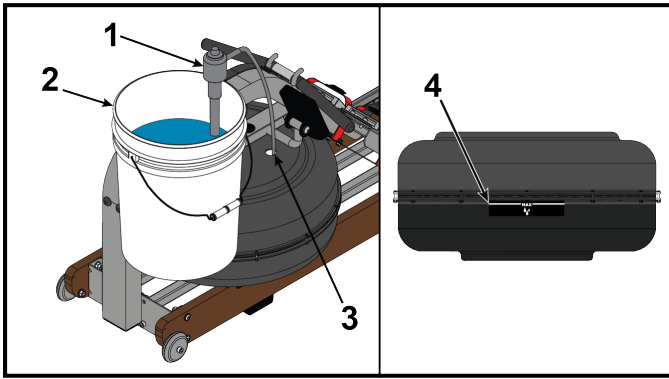

Item	Description	Qty.
1	Siphon	1
2	Bucket	1
3	Siphon hose in tank	1
4	Max fill line	1

4. Pump 4.5 Gallons (17 Liters) of water into tank.

NOTE: The siphon valve must be closed to allow siphoning action to occur.

NOTE: Do not fill past max fill line on side of tank.

TIP: Placing the bucket in an elevated position will allow the siphon to continually pump water into the tank.

NOTE: Opening the siphon valve will stop the pumping action. Use this feature to avoid water spillage when nearing filling completion.

5. Drop one water treatment tablet into tank. Add a water treatment tablet every six months.

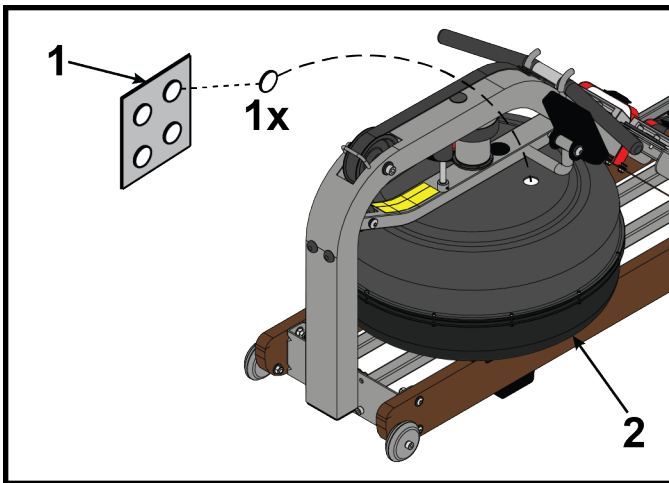

Item	Description	Qty.
1	Water treatment tablet	1
2	Tank	1

6. Install cap to tank.

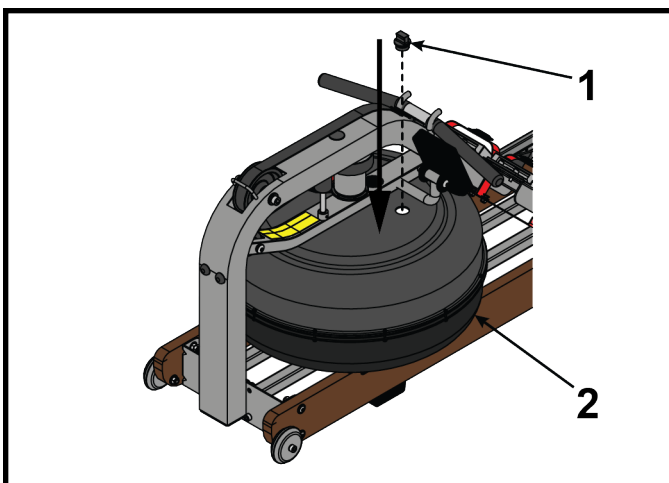

Item	Description	Qty.
1	Cap	1
2	Tank	1

3. Operation

Computer Instructions with Bluetooth

TIME: Auto start elapsed time.

500M TIME: Time to row 500 meters.

PULSE: Requires optional receiver and chest strap (sold separately). Updated every two seconds.

SPM: Strokes per minute updated each stroke.

CAL HOUR: Calories burned per hour at the current Watts. Shows total calories burned when exercise is stopped.

LEVEL UP / DOWN: Auto-level adjust to the Adjuster Knob on the tank.

WATTS: Unit of power updated every second.

DISTANCE: Updated every second.

POWER GRAPH: Press **RESET** to change display from POWER CURVE to Cumulative Power Graph.



Auto Start

Auto Start: Commence rowing to activate.

RESET ALL VALUES: Hold button down for 3 seconds to **RESET**.

DISTANCE:

Add 100m distance, up to 1000m then add 500m, each button push to accumulate required distance then begin rowing to initiate distance count down.

AUTO-PAUSE: A temporary halt in exercise will result in the following:

- For over 5 seconds and under 5 minutes:
- SPM / 500 METER / WATT to zero.
- Distance / TIME values are saved.
- CAL per hour defaults to Total CAL.
- A resumption in exercise in less than 5 minutes will resume Distance / TIME from saved values automatically.

AUTO POWER DOWN: Calories burned per hour at the current Watts. Shows total calories burned when exercise is stopped.

LEVEL UP / DOWN: Over 5 minutes. All values revert to zero after restart.

WARNING: Heart rate monitoring systems may be inaccurate. Over exercise may result in serious injury or death. If you feel faint, stop exercising immediately.

NOTE:

BLUETOOTH CONNECTIVITY: To enable Bluetooth connectivity with any compatible smart device, hold UP and DOWN buttons together for 5 seconds to initiate Bluetooth function. Open app and connect. Compatible with fitness apps such as the FluidRower app, available for iOS and Android.

Calibration Procedure

1. Press and hold **RESET** and **DOWN** for 5 Seconds. Display will show 



2. Turn knob to Level 1.

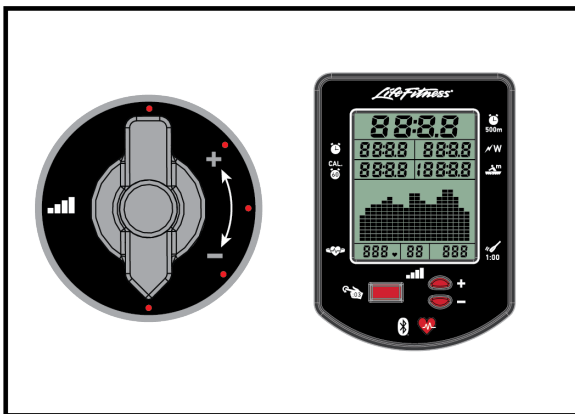

3. Press **RESET**.
4. Display will now show Level 2.
5. Level 1 Calibration is complete.

- Turn knob to Level 2.

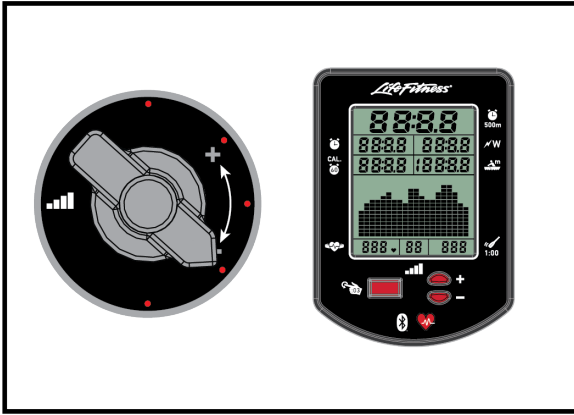

- Press **RESET**.
- Display will now show Level 3.
- Level 2 Calibration is complete.
- Repeat for levels 3, 4, and 5.
- At level 5, press **RESET** and display will show level 5.
- Calibration is complete.

Resistance

The level of resistance is determined by the level indicator located on the top of the tank. Level one indicates lightest resistance, level 5 represents heaviest resistance. Allow for up to ten strokes after adjusting resistance knob for desired resistance level to be reached.

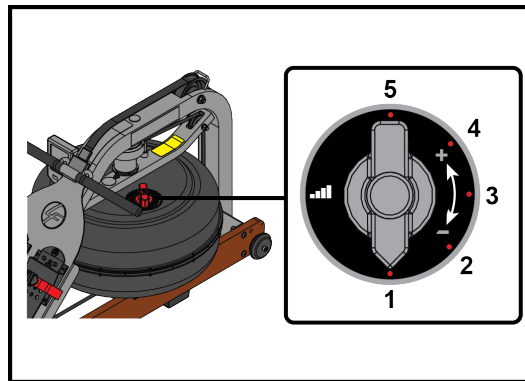

Slider Footplate

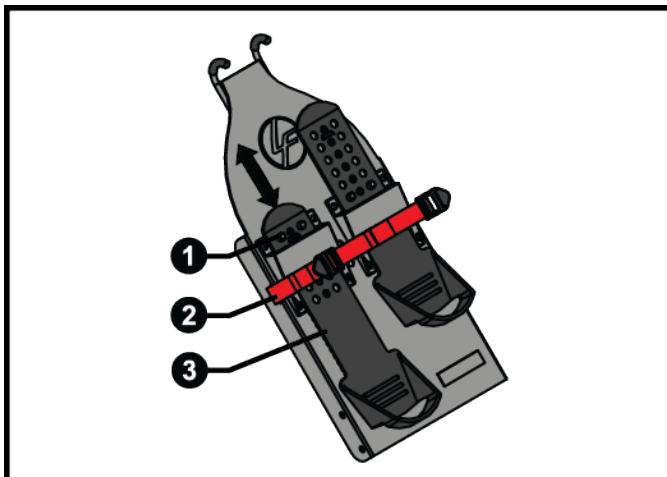

Item	Description	Qty.
1	Mounting pegs	4
2	Foot strap	2
3	Slide	2

The Slider Footplate is designed to fit a wide range of foot sizes, and is very simple to use.

To adjust, lift the top of the sliding portion of the footplate and slide up or down. The numbers 1-6 represent a guideline from which the proper length can be determined. Secure the plate onto the mounting pegs and push down firmly to lock into position.



Tighten the Footstraps securely and begin your workout.



WARNING: Never operate this rower without feet properly secured in Foot straps, or without the sliding portion of the Slider Footplate locked into position!

How to Row

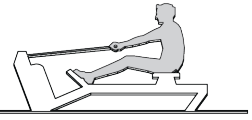
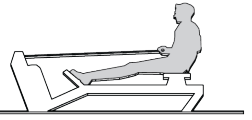
1. Begin the stroke comfortably forward and push strongly back with your legs while keeping your arms and back straight.

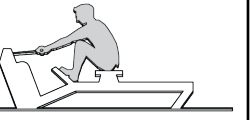
Catch	Drive	Finish	Recovery	Catch
Comfortably forward with straight back and arms.	Push with the legs while arms remain straight.	Pull through with arms and legs rocking slightly back over your pelvis.	Upper body tips forward over your pelvis and move forward.	Catch and begin again.
				

2. Begin to pull your arms back as they pass over your knees and continue the stroke through to completion rocking slightly back over your pelvis.
3. Return to the starting position and repeat.
4. For further details regarding rowing technique please refer to our website at www.lifefitness.com.

How Often

- Begin with 5 minute training sessions once a day and aim for around 2:30 to 2:45 for 500m time. Row at a pace that keeps the water circulating continuously between strokes.
- Progress a few minutes more each day until you are comfortable with 30-45 minutes training time 3 or 4 times a week.
- This will provide aerobic endurance benefits, muscle toning and sufficient calorie burning to form part of a weight loss program.

 **WARNING:** Always consult a doctor before beginning an exercise program. Stop immediately if you feel faint or dizzy.

4. Maintenance

All preventive maintenance activities must be performed on a regular basis. Performing routine preventive maintenance actions can aid in providing safe, trouble-free operation of all *Life Fitness* equipment.

Life Fitness is not responsible for performing regular inspection and maintenance actions for your machines. Instruct all personnel in equipment inspection and maintenance actions and also in accident reporting and recording. *Life Fitness* representatives are available to answer any questions that you may have.

Service Schedule

Item	Time Frame	Instructions	Notes
Seat and Seat Rails	Weekly	Wipe down seat wheels and side rails with lint free cloth.	
Frame	Weekly	Wipe down Frame with lint free cloth.	
Tank and Water Treatment	12 months to 2 years	Follow instructions as specified in the Water Treatment Procedure section of this manual.	
Bungee Cord	Check every hundred hours for correct tension and for signs of wear.	The Bungee Cord should last for many years. If a Bungee Cord change is required, please contact your local service representative or contact Customer Service.	
Rowing Belt	Check every hundred hours for correct tension and for signs of wear.	The Rowing Belt should provide many years of trouble free use. If a Rowing Belt change is required, please contact your local service representative or contact Customer Service.	

Water Treatment Procedure

Add one Water Treatment Tablet per full tank.

NOTE: The amount of water treatment can vary widely depending on the unit's location and exposure to sunlight. DO NOT, UNDER ANY CIRCUMSTANCES USE OTHER TREATMENT TABLETS OTHER THAN THOSE SUPPLIED WITH YOUR UNIT.

The unit includes Water Treatment Tablets, which is sufficient for several years of water treatment. Treat when water becomes discolored or shows signs of Algae/Bacterial growth. To purchase additional Water Treatment Tablets, contact Customer Service.

Long Term Water Treatment

Do not use any water treatment other than the tablets supplied with this unit. For replacement tablets, contact Customer Service. Water treatment schedules for the *Row HX Trainer* will vary according to the fluid tanks exposure to sunlight, but expect 8-12 months near a bright, sunlit window and 2 years or more for a darker location. At the point of finding the water slightly cloudy, add a chlorine Tablet.

 **CAUTION:** It is recommended that a drop cloth be used under the fluid tank whenever the tank is open for water treatment.

 **CAUTION:** Do not fill past the calibration mark as indicated on the tank level sticker or water spillage can occur.

Vertical Storage (Not Available in All Areas)

The *Row HX Trainer* can be stored in a vertical, upright position with use of the optional vertical storage stand specified for this machine and with water in the tank. For safety, store on level ground in a suitable location, such as a corner of a room. It is recommended that a non-marring material (such as a thin carpet or small towel) be placed under the upper rear of the unit to avoid marring the unit or the floor.

Optional Storage (Not Available in All Areas)

1. Install the Z brackets, bolts, and knobs onto the stand base by hand.

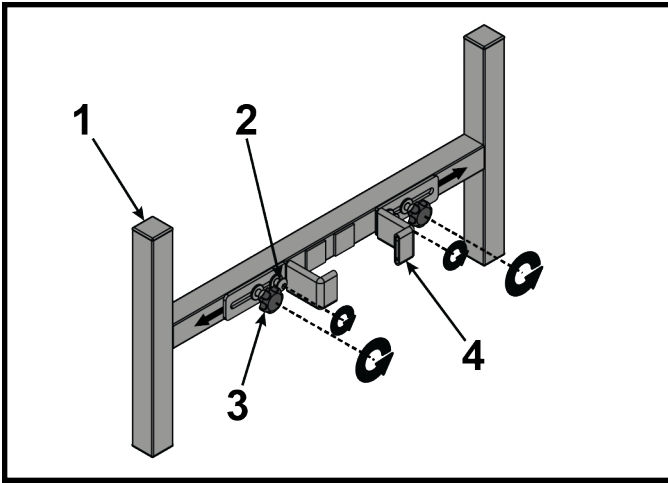

Item	Description	Qty.
1	Stand base	1
2	Bolt	2
3	Knob	2
4	Z bracket	2

2. Install the stand base onto the frame as shown. Tighten knob by hand to secure stand base to rower.

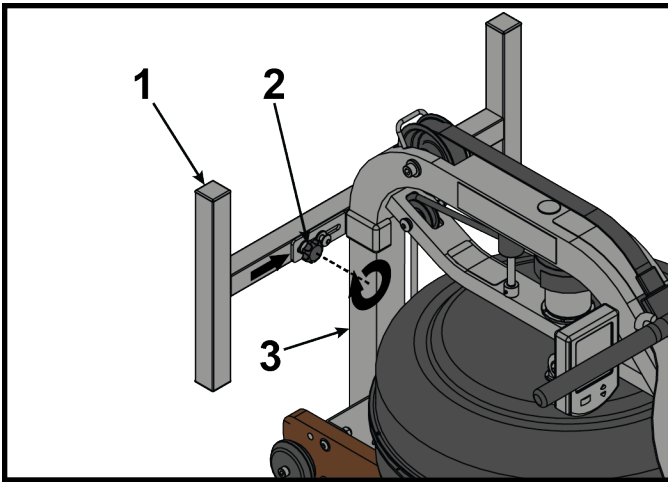

Item	Description	Qty.
1	Stand base	1
2	Knob	2
3	Frame	2

3. Stand rower up vertically.

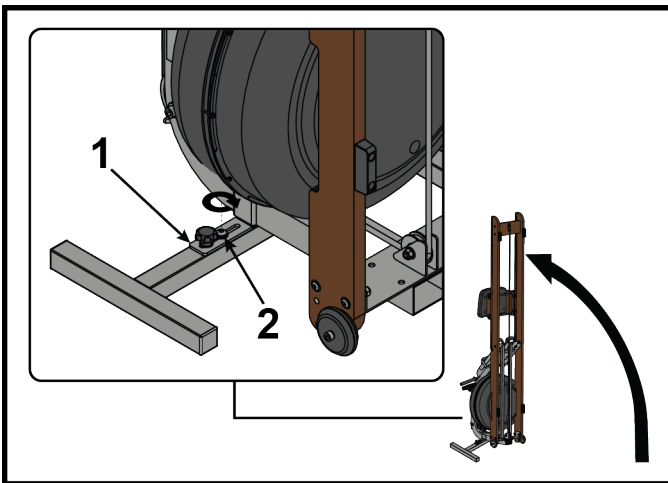

Item	Description	Qty.
1	Stand base	1
2	Bolt	2

4. Tighten bolts to stand base using an 8 mm Allen wrench. Tighten to 13 ft.-lbs. (17.6 Nm).

5. Troubleshooting

Console

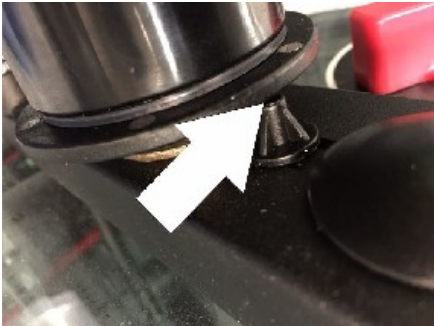
Fault	Probable Cause	Solution
Computer screen illuminates, but does not register when rowing.	Loose or failed connection/ Sensor gap too wide (see erratic computer display).	Check that the computer lead is connected properly. If connected properly check sensor gap. Contact your local service center if this fails to address the problem.
The Row HX Trainer computer does not illuminate after battery installation.	Batteries installed incorrectly or need replacing.	Reinstall batteries in correct position and try again. If the LCD screen fails to illuminate, try rotating the batteries slightly in the computer. If this fails, contact your local service center.
The Row HX Trainer computer display is erratic while displaying SPM and 500 meter times.	Gap between sensor and magnetic ring is too wide.	Adjust sensor location using rear sliding adjustment located near timing pulley. 
The monitor level is not synchronized with the tank level	Monitor level needs to be re calibrated	Please refer to "Calibration Procedure" section of this manual

Mechanical

Fault	Probable Cause	Solution
Water changes color or becomes cloudy.	Rower is in direct sunlight or has not had water treatment.	Change rower location to reduce direct exposure to sunlight. Add 1x Water Treatment Tablet or change tank water as directed in the water treatment section of this manual. Consider using distilled water to refill tank.
Rowing stroke return too light.	Bungee not under enough tension.	Tighten by small increments using the bungee tie off tab point and test tension by allowing the rowing handle to return to its furthest point forward while still having some slight tension. Note: Light fraying of the bungee cord is normal.
Cracked water tank	Tank hardware over tightened.	Make sure to not over tighten the tank bolts. The water tank bolts must be torqued to 9.5 in-lb (11 kg-cm). Replace water tank if leaking.
	Tank material degraded by using chemical cleaner to wipe tank.	Only wipe the tank with water and a clean cloth. Do NOT use any chemical content cleaner. Replace water tank if leaking.
	Rower in direct sunlight	Change rower location to reduce direct exposure to sunlight. Direct sunlight could have adverse affects on tank durability.

Console Firmware Update

Tools Required: Smartphone

Time: 10 minutes

This procedure needs to be performed for each rower. The bluetooth connection can only pair one phone to one rower at a time.

1. Download the **Fluid Connect** from an app store to a phone.
This download includes the firmware, takes a minute to download, and is under 100k bytes.
2. Tap the app on the phone to open. Turn the rower console on at the same time.
3. Tap the center of the app screen on the phone to start.
4. Tap **Next** on the phone.
5. On the rower, Push and hold the **Up** and **Down** buttons for 3 seconds to enable the Bluetooth function on the console.

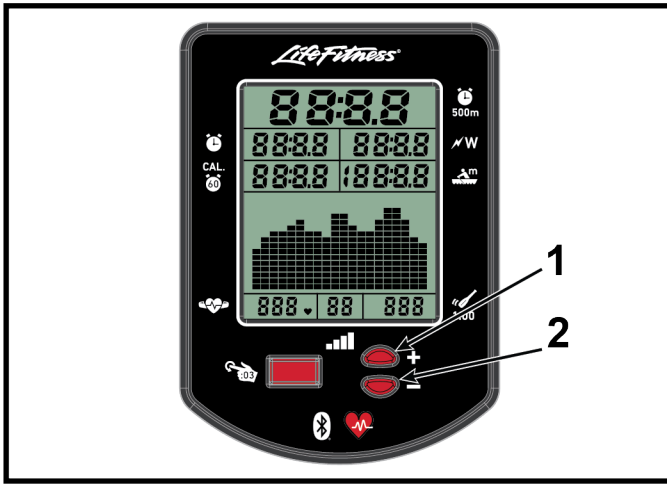

Item	Description	Qty
1	Up button	1
2	Down button	1

6. Tap **Next** on the phone.
7. Press the **Up** button to let console communicate with the phone.
8. Tap **Next** on the phone.
Console will start communicating with the phone via Bluetooth. Once the phone has located the console, a 4 digit number will show on both the console and the phone.
9. Press **UPDATE** to activate the firmware update. The app will automatically choose the latest firmware version for your console.

When the update process is completed, the console will reboot and restart.

6. Warranty

What is Covered

This Row HX Trainer is warranted to be free of all defects in material and workmanship.

Who is Covered

The original purchaser or any person receiving the product as a gift from the original purchaser. Warranty will be voided on subsequent transfers.

How Long is it Covered

Residential: All electrical and mechanical components and labor are covered, after the date of purchase, as listed on the chart below. Non-Residential: Warranty void (the Row HX Trainer is intended for residential use only).

Structural Frame (Not coatings)	Tank	Mechanical	Labor	All other
5 Years	3 Years	2 Years	1 Year	1 Year

Who Pays Shipping and Insurance for Service

If the Product or any warranted part must be returned to a service facility for repairs, Life Fitness will pay all shipping and insurance charges during the warranty period (within the United States only). The purchaser is responsible for shipping and insurance charges after the warranty has expired.

What We Will Do To Correct Covered Defects

We will ship to you any new or rebuilt replacement part or component, or at our option, replace the Product. Such replacement parts are warranted for the remaining portion of the original warranty period.

What is Not Covered

Any failures or damage caused by unauthorized service, misuse, accident, negligence, improper assembly or installation, debris resulting from any construction activities in the Product's environment, rust or corrosion as a result of the Product's location, alterations or modifications without our written authorization, or by failure on your part to use, operate and maintain the Product as set out in your Operation Manual.

All terms of this warranty are void if this product is moved beyond the continental borders of the United States of America (excluding Alaska, Hawaii and Canada) and are then subject to the terms provided by that country's local authorized Life Fitness Family of Brands representative.

What You Must Do

Retain proof of purchase. use, operate and maintain the Product as specified in the Manual; notify the place of purchase of any defect within 10 days after discovery of the defect; if instructed, return any defective part for replacement or, if necessary, the entire Product for repair. Life Fitness reserves the right to decide whether or not a product is to be returned for repair.

User Manual

It is VERY IMPORTANT THAT YOU READ THE MANUAL before operating the Row HX Trainer. Remember to perform the periodic maintenance requirements specified in the Manual to assure proper operation and your continued satisfaction.

Product Registration

Register online at <https://lifefitness.com/home/support/product-registration>. Our receipt assures that your name, address and date of purchase are on file as a registered owner of the Product. Being a registered owner assures coverage in the event you lose your proof of purchase. Please retain your proof of purchase, such as your bill of sale or receipt.

How to Get Parts and Service

Refer to the Corporate Headquarters section of this manual for your local service contact information. Reference your name, address and the serial number of your Product (consoles and frames may have different serial numbers). They will tell you how to get a replacement part, or, if necessary, arrange for service where your Product is located.

Exclusive Warranty

THIS LIMITED WARRANTY IS IN LIEU OF ALL OTHER WARRANTIES OF ANY KIND EITHER EXPRESSED OR IMPLIED, INCLUDING BUT NOT LIMITED TO THE IMPLIED WARRANTIES OF MERCHANTABILITY AND FITNESS FOR A PARTICULAR PURPOSE, AND ALL OTHER OBLIGATIONS OR LIABILITIES ON OUR PART. We neither assume nor authorize any person to assure for us any other obligation or liability concerning the sale of this Product. Under no circumstances shall we be liable under this warranty, or otherwise, of any damage to any person or property, including any lost profits or lost savings, for any special, indirect, secondary, incidental or consequential damages of any nature arising out of the use of or inability to use this Product. Some states do not allow the exclusion or limitation of implied warranties or of liability for incidental or consequential damages, so the above limitations or exclusions may not apply to you. Warranty coverages and terms may differ outside the United States. Please contact the Life Fitness office servicing your country (contact information found at the front of this manual) or visit the applicable local Life Fitness website to receive the specific warranty information for your country.

Changes in Warranty Not Authorized

No one is authorized to change, modify or extend the terms of this limited warranty.

Effects of State Laws

This warranty gives you specific legal rights, and you may have other rights which vary from state to state and country by country.

