

Row CX Trainer

Row CX Owner's Manual



Corporate Headquarters

Columbia Centre III, 9525 West Bryn Mawr Avenue, Rosemont, Illinois 60018 • U.S.A.
847.288.3300 • FAX: 847.288.3703
Service phone number: 800.351.3737 (toll-free within U.S.A., Canada)
Global Website: www.lifefitness.com

International Offices

AMERICAS North America Life Fitness, Inc.

Columbia Centre III
9525 West Bryn Mawr Avenue
Rosemont, IL 60018 U.S.A.
Telephone: (847) 288 3300
Fax: (847) 288 3703
Service Email: customersupport@lifefitness.com
Service Website: www.lifefitness.com/parts
Sales/Marketing Email:
consumerproducts@lifefitness.com
Operating Hours: 7:00 am-6:00 pm (CST)

Brazil Life Fitness Brasil

Av Reboucas 2315
Jd. Paulistano
São Paulo, SP 05401-300
BRAZIL
SAC: 0800 773 8282
Telephone: +55 (11) 3095 5200
Fax: +55 (11) 3095 5201
Service Email: suporte@lifefitness.com.br
Sales/Marketing Email: lifefitness@lifefitness.com.br
Service Operating Hours: 9:00 - 17:00 (BRT)
(Monday-Friday)
Store Operating Hours: 9:00 -20:00 (BRT)
(Monday-Friday)
10:00 - 16:00 (BRT) (Saturday)

Latin America & Caribbean* Life Fitness, Inc.

Columbia Centre III
9525 West Bryn Mawr Avenue
Rosemont, IL 60018 U.S.A.
Telephone: (847) 288 3300
Fax: (847) 288 3703
Service Email: customersupport@lifefitness.com
Service Website: www.lifefitness.com/parts
Sales/Marketing Email:
consumerproducts@lifefitness.com
Operating Hours: 7:00 am-6:00 pm (CST)

EUROPE, MIDDLE EAST, & AFRICA (EMEA) Netherlands & Luxemburg Life Fitness Atlantic BV

Bijddorplein 25-31
2992 LB Barendrecht
THE NETHERLANDS
Telephone: (+31) 180 646 666
Fax: (+31) 180 646 699
Service Email: service.benelux@lifefitness.com
Sales/Marketing Email:
marketing.benelux@lifefitness.com
Operating Hours: 9:00h-17:00h (CET)

United Kingdom & Ireland Life Fitness UK LTD

Queen Adelaide
Ely, Cambs, CB7 4UB
Telephone: General Office (+44) 1353.666017
1353.666017
Customer Support (+44) 1353.665507
Fax: (+44) 1353.666018
Service Email: uk.support@lifefitness.com
Sales/Marketing Email: life@lifefitness.com
Operating Hours:
General Office: 9.00am - 5.00pm (GMT)
Customer Support: 8.30am - 5.00pm (GMT)

Germany & Switzerland Life Fitness Europe GMBH

Siemensstraße 3
85716 Unterschleißheim
GERMANY
Telephone: (+49) 89.31 77 51.0 (Germany)
(+41) 0848 000 901 (Switzerland)
Fax: (+49) 89.31 77 51.99 (Germany)
(+41) 043 818 07 20 (Switzerland)
Service Email: kundendienst@lifefitness.com
Sales/Marketing Email: kundenberatung@lifefitness.com
Operating Hours: 08.30 -16.30h (CET)

Austria Life Fitness Austria

Vertriebs G.m.b.H.
Dückerstraße 7-9/3/36
1220 Vienna
AUSTRIA
Telephone: (+43) 1.61.57.198
Fax: (+43) 1.61.57.198.20
Service Email: kundendienst@lifefitness.com
Marketing/Sales Email: kundenberatung@lifefitness.com
Operating Hours: 08:30-16:30h (MEZ)

Spain Life Fitness IBERIA

C/Frederic Mompou 5,1ª^a
08960 Sant Just Desvern Barcelona
SPAIN
Telephone: (+34) 93.672.4660
Fax: (+34) 93.672.4670
Service Email: servicio.tecnico@lifefitness.com
Sales/Marketing Email: info.iberia@lifefitness.com
Operating Hours:
9.00h-18.00h (Monday-Thursday)
8.30h-15.00h (Friday)

Belgium Life Fitness Benelux NV

Parc Industriel de Petit-Rechain
4800 Vierviers
BELGIUM
Telephone: (+32) 87 300 942
Fax: (+32) 87 300 943
Service Email: service.benelux@lifefitness.com
Sales/Marketing Email:
marketing.benelux@lifefitness.com
Operating Hours: 9.00h -17.00h (CET)

All Other EMEA Countries & Distributor Business C-EMEA*

Bijddorplein 25-31
2992 LB Barendrecht
THE NETHERLANDS
Telephone: (+31) 180 646 644
Fax: (+31) 180 646 699
Service Email: service.db.cemea@lifefitness.com
Sales/Marketing Email:
marketing.db.cemea@lifefitness.com
Operating Hours: 9.00h-17.00h (CET)

ASIA PACIFIC (AP) Japan

Life Fitness Japan

Japan Nippon Brunswick Bldg., #8F
5-27-7 Sendagaya
Shibuya-Ku, Tokyo
Japan 151-0051
Telephone: (+81) 3.3359.4309
Fax: (+81) 3.3359.4307
Service Email: service@lifefitnessjapan.com
Sales/Marketing Email: sales@lifefitnessjapan.com
Operating Hours: 9.00h-17.00h (JAPAN)

Hong Kong Life Fitness Asia Pacific LTD

32/F, Global Trade Square
21 Wong Chuk Hang Road
HONG KONG
Telephone: (+852) 2575.6262
Fax: (+852) 2575.6894
Service Email: HongKongEnquiry@lifefitness.com
Sales/Marketing Email:
Marketing.HK.Asia@lifefitness.com
Operating Hours: 9.00h-17.00h
Service Operating Hours: 9.00h-18.00h

All Other Asia Pacific countries & distributor business Asia Pacific*

32/F, Global Trade Square
21 Wong Chuk Hang Road
HONG KONG
Telephone: (+852) 2575.6262
Fax: (+852) 2575.6894
Service Email: HongKongEnquiry@lifefitness.com
Sales/Marketing Email:
Marketing.HK.Asia@lifefitness.com
Operating Hours: 9.00h-17.00h
Service Operating Hours: 9.00h-18.00h

*Also check www.lifefitness.com for local representation or distributor/dealer

Table of Contents

Safety

Safety Instructions.....	5
Access Control.....	5
Installation.....	5
Proper Usage.....	5
Inspection.....	6
Operating Warnings.....	6

Specifications

Specifications - Row CX Trainer.....	7
--------------------------------------	---

Operation

Computer Instructions.....	8
Tank Filling.....	8
Options.....	9
Slider Footplate.....	9
Resistance.....	10
How to Row.....	10
How Often.....	10
Vertical Storage.....	11

Maintenance

Service Schedule.....	12
Water Treatment Procedure.....	12
Long Term Water Treatment.....	12
Troubleshooting.....	12

Warranty

What is Covered.....	14
Who is Covered.....	14
How Long is it Covered.....	14
Who Pays Shipping and Insurance for Service.....	14
What We Will Do To Correct Covered Defects.....	14
What is Not Covered.....	14
What You Must Do.....	14
User Manual.....	14
Product Registration.....	14
How to get Parts and Service.....	14
Exclusive Warranty.....	15
Changes in Warranty Not Authorized.....	15
Effects of State Laws.....	15

1. Safety

Safety Instructions

- Before using this product, it is essential to read this ENTIRE operation manual and ALL instructions. The Row CX Trainer is intended for use solely in the manner described in this manual.
- UNDERSTANDING EACH AND EVERY WARNING TO THE FULLEST IS IMPORTANT. IF ANY OF THESE WARNINGS ARE UNCLEAR, CONTACT LIFE FITNESS CUSTOMER SERVICE IMMEDIATELY AT 1-800-735-3867.
- This equipment is categorized as class HC per EN ISO 20957-1. As such this equipment is only intended for home use only. It is not intended for commercial, institutional and/or studio facilities. Contact LIFE FITNESS with any questions regarding this classification.
- It is recommended that all users of LIFE FITNESS exercise equipment be informed of the following information prior to use.
- As with any piece of fitness equipment, consult a physician before beginning your Row CX Trainer exercise program.
- Please be aware that any fitness regiment, before being undertaken, is best preceded by a physical checkup from a certified physician.
- Injuries to health may result from incorrect or excessive training.
-  **Warning:** Heart rate monitoring systems may be inaccurate. Over exercise may result in serious injury or death. If you feel faint or dizzy stop exercising immediately.
- Stop the machine immediately if any signs of excessive wearing is present on the belts, pulleys and bungee cords. Do not use unit until said parts are repaired or replaced.
- Do not allow children unattended access to the machine.
- The Row CX Trainer can stand vertically for storage. When doing so, please follow the instructions given in the Basic Operation section of this manual.
- Please keep hands away from moving parts, as indicated by the warning label on the mainframe of your machine.
- If any of the adjustment devices are left projecting, they could interfere with the user's movement.
- Do not store in freezing conditions with water in the tank as it can expand and crack the components.
- Health and Environmental Regulations Warning - This product may contain chemicals known to the State of California to cause cancer, birth defects, or other reproductive harm. For more information related to the European Commission Regulation (EC) No. 1907/2006 (REACH) and the California Safe Drinking Water and Toxic Enforcement Act of 1986 (Proposition 65), please visit <https://www.lftechsupport.com/web/guest/environmental-regulations-information>.

Access Control

This fitness equipment is not intended for use by persons (including children) with reduced physical, sensory or mental capabilities, or lack of experience and knowledge, unless they have been given supervision or instruction concerning use of the equipment by a person responsible for their safety.

Installation

- Place on a stable, flat surface in a horizontal position during use for maximum stability.
- Check all belts, pulleys and bungee cords regularly for signs of wear, and replace if needed.
- Check regularly and follow all instructions for maintenance as specified in this manual.
- Replace immediately any defective parts and do not operate unit until all repairs are complete.

Proper Usage

- Do not use any equipment in any way other than designed or intended by the manufacturer. It is imperative that LIFE FITNESS equipment is used properly to avoid injury.
- Injuries may result if exercising improperly or excessively. It is recommended that all individuals consult a physician prior to commencing an exercise program. If at any time during exercise you feel faint, dizzy or experience pain, STOP EXERCISING and consult your physician.
- Keep body parts (hands, feet, hair, etc.), clothing and jewelry away from moving parts to avoid injury.

- Follow instructions provided in this manual for correct foot position and basic rowing techniques.
- For more detailed rowing techniques, please refer to our International website www.lifefitness.com

Inspection

- DO NOT use or permit use of any equipment that is damaged and/or has worn or broken parts. For all LIFE FITNESS equipment use only replacement parts supplied by LIFE FITNESS.
- Cables and belts pose an extreme liability if used when frayed. Always replace any cable or belt at first sign of wear (consult LIFE FITNESS if uncertain).
- MAINTAIN LABELS AND NAME PLATES - Do not remove labels for any reason. They contain important information. If unreadable or missing, contact LIFE FITNESS for a replacement.
- EQUIPMENT MAINTENANCE - Preventative maintenance is the key to smooth operating equipment as well as to keep your liability to a minimum. Equipment needs to be inspected at regular intervals.
- Ensure that any person(s) making adjustments or performing maintenance or repair of any kind is qualified to do so.
- DO NOT ATTEMPT TO USE OR REPAIR ANY ACCESSORY APPROVED FOR USE WITH THE LIFE FITNESS EQUIPMENT WHICH APPEARS TO BE DAMAGED OR WORN.
- Check all belts, pulleys and bungee cords regularly for signs of wear, and replace if needed.
- Check regularly and follow all instructions for maintenance as specified in this manual.
- Replace immediately any defective parts and do not operate unit until all repairs are complete.

Operating Warnings

- Keep children away from LIFE FITNESS equipment. Parents or others supervising children must provide close supervision of children if the equipment is used in the presence of children.
- Do not allow users to wear loose fitting clothing or jewelry while using equipment. It is also recommended to have users secure long hair back and up to avoid contact with moving parts.
- All bystanders must stay clear of all users, moving parts and attached accessories and components while machine is in operation.

2. Specifications

Specifications - Row CX Trainer

Life Fitness Row CX Trainer is not suitable for therapeutic purposes.

Product Class	HC
Braking System	Speed Independent
Product Gross Weight	70.99lb (32.2kg)
Max User Weight	330lb (150kg)
Minimum Safe Operating Surface Area	131.09" (333cm) Length x 67.71" (172cm) Width
Dimensions	83.85" (213cm) Length x 20.47" (52cm) Width x 22.04" (56cm) Height

The live area shall be not less than 23.62" (60cm) greater than the training area in the directions from which the equipment is accessed. The live area must also include the area for emergency dismount.

Live area and Training area

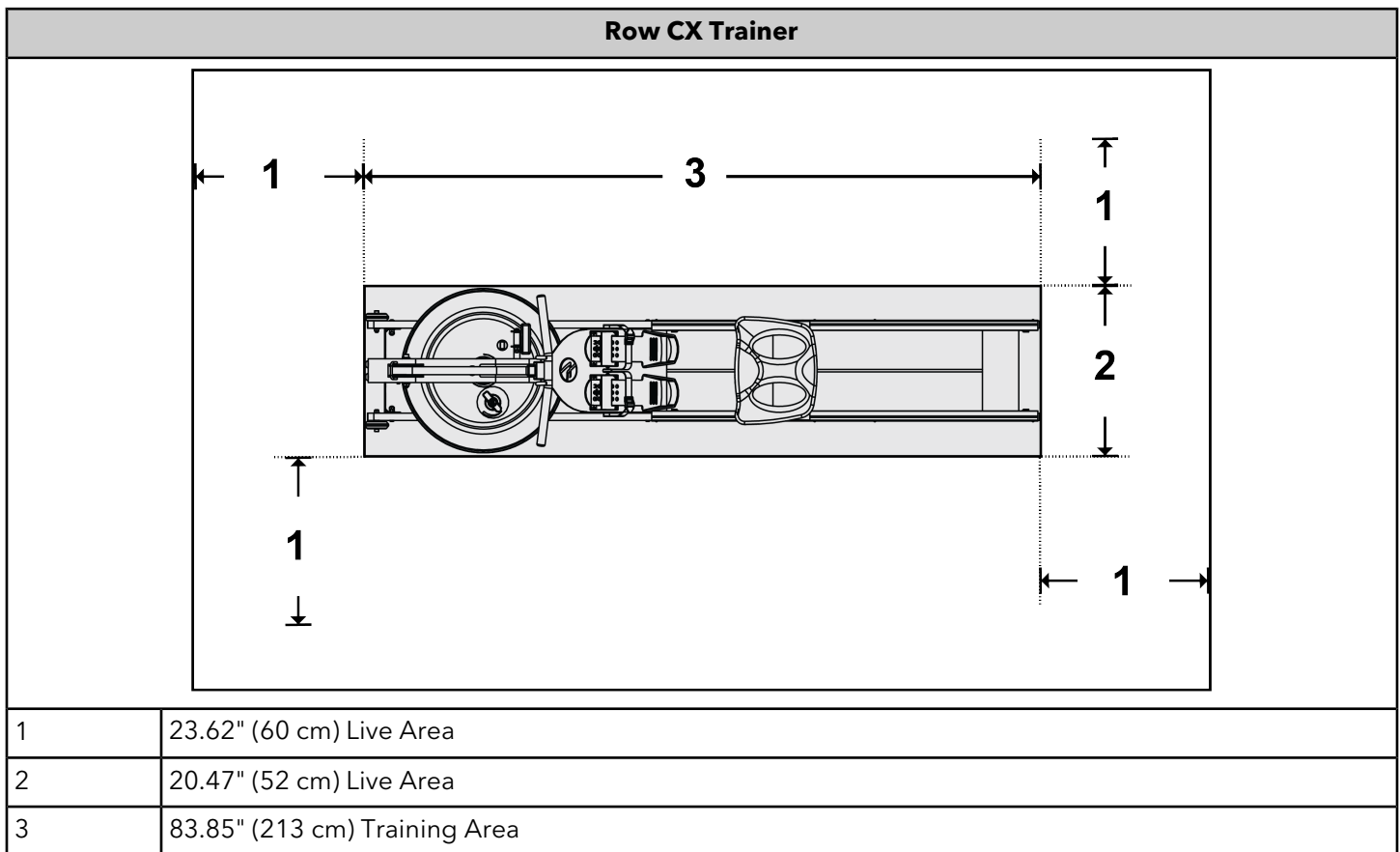

3. Operation

Computer Instructions

TIME: Auto start elapsed time.

500M TIME: Time to row 500 meters, updated at the completion of each stroke.

PULSE: Requires optional receiver and chest strap (sold separately).



SPM: Strokes per minute updated each stroke.

CAL HOUR: Updated each stroke.

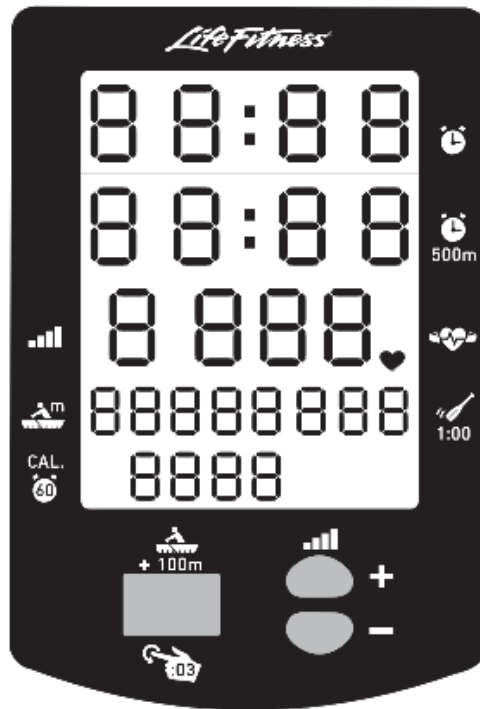
LEVEL UP/ DOWN: Use the LEVEL UP/DOWN buttons in conjunction with the Fluid Tank Resistance Adjuster Handle for accurate 500M/Distance/CAL/WATTS.



Tank Filling

-  **Caution:** Use a drop cloth under the tank when filling to avoid staining floor or carpet.
-  **Caution:** Do not fill past the calibration mark as indicated on the tank level sticker or water spillage can occur.

<ul style="list-style-type: none">• Remove black plug only for filling. Fill at MAX resistance + sign only.• Once filling is complete, insert tank plug into place.	
--	--

-  **Warning:** Do not insert fingers into tank!

1. Filling requires a large bucket (not supplied) and the Fluid Rower Siphon (included). Filling will take approximately 4.5 gallons (17 liters) of water.
2. Remove the tank plug on top of tank and insert the flexible tube into the rear of the tank while keeping the rigid hose in the bucket.
 🖱️ **Note:** Where water quality is known to be poor, Life Fitness recommends the use of distilled water.
3. Move the adjuster knob to the plus sign (+), and begin filling. Note: The siphon valve must be closed to allow siphoning action to occur. Tip: Placing the bucket in an elevated position will allow the siphon to continually pump water into the tank. Do not fill past the calibration mark indicated on the tank!
 🖱️ **Note:** Opening the siphon valve will stop the pumping action. Use this feature to avoid water spillage when nearing filling completion.
4. Once filling is complete (to the proper calibration level as indicated on the tank), follow water treatment schedule as shown.

Options

AUTO START: Commence rowing to activate.

RESET ALL VALUES: Hold button down for 3 seconds first to RESET.

DISTANCE: Add 100m distance, up to 1000m then add 500m, each button push to accumulate required distance then begin rowing to initiate distance count down.

AUTO-PAUSE: A temporary halt in exercise will result in the following:

- **For over 5 seconds and under 5 minutes:**
- SPM/500METER/WATT to zero.
- Distance/TIME values are saved.
- CAL per hour defaults to Total CAL.
- A Resumption in exercise in less than 5 minutes will resume Distance TIME/ from saved values automatically.

AUTO POWER DOWN: Over 5 minutes. All values revert to zero after restart.

⚠️ **Warning:** Heart rate monitoring systems may be inaccurate. Over exercise may result in serious injury or death. If you feel faint, stop exercising immediately.

Slider Footplate

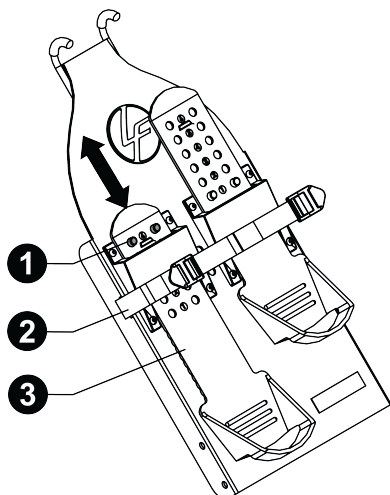

	Description	Qty.
1	Mounting pegs	4
2	Foot strap	2
3	Slide	2

The Slider Footplate is designed to fit a wide range of foot sizes, and is very simple to use.

To adjust, lift the top of the sliding portion of the footplate and slide up or down. The numbers 1-6 represent a guideline from which the proper length can be determined. Secure the plate onto the mounting pegs and push down firmly to lock into position.

Tighten the Footstraps securely and begin your workout.

Warning: Never operate this rower without feet properly secured in Footstraps, or without the sliding portion of the Slider Footplate locked into position!

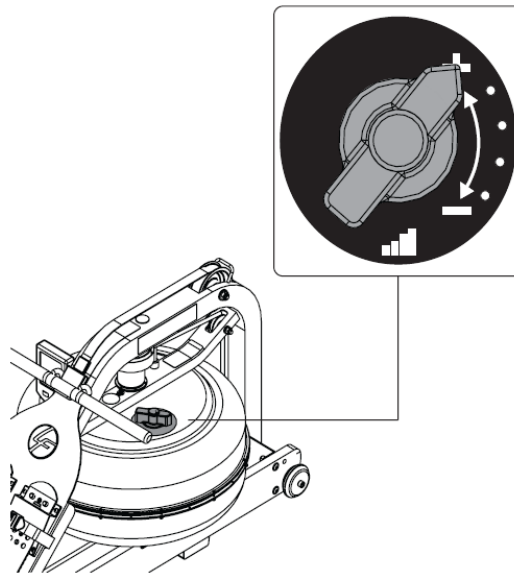

Resistance

The level of resistance is determined by the level indicator located on the top of the tank. Level one indicates lightest resistance, level four represents heaviest resistance. Allow for up to ten strokes after adjusting resistance handle for desired resistance level to be reached.

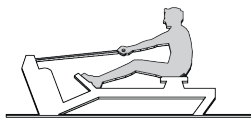
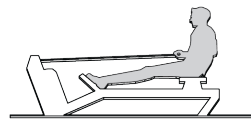
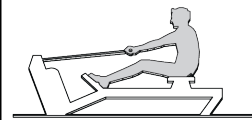

How to Row

1. Begin the stroke comfortably forward and push strongly back with your legs while keeping your arms and back straight.

Catch	Drive	Finish	Recovery	Catch
Comfortably forward with straight back and arms.	Push with the legs while arms remain straight.	Pull through with arms and legs rocking slightly back on your pelvis.	Upper body tips forward over your pelvis and move forward.	Catch and begin again.
				

2. Begin to pull your arms back as they pass over your knees and continue the stroke through to completion rocking slightly back over your pelvis.
3. Return to the starting position and repeat.
4. For further details regarding rowing technique please refer to our website at www.lifefitness.com.

How Often

- Begin with 5 minute training sessions once a day and aim for around 2:30 to 2:45 for 500m time. Row at a pace that keeps the water circulating continuously between strokes.
- Progress a few minutes more each day until you are comfortable with 30-45 minutes training time 3 or 4 times a week.
- This will provide aerobic endurance benefits, muscle toning and sufficient calorie burning to form part of a weight loss program.

 **Warning:** Always consult a doctor before beginning an exercise program. Stop immediately if you feel faint or dizzy.

Vertical Storage

The Life Fitness Row CX Trainer can easily be stored in a vertical, upright position. For safety, choose a suitable location, such as a corner of a room. It is recommended that something soft (such as carpet or a small towel) be placed under the upper rear of the unit to avoid marring the unit or the floor.

4. Maintenance

Service Schedule

Item	Time Frame	Instructions	Notes
Seat and Seat Rails	Weekly	Wipe down Seat Rails with lint free cloth.	
Frame	Weekly	Wipe down Frame with lint free cloth.	
Tank and Water Treatment	12 months to 2 years	Follow instructions as specified in the "Water Treatment Procedure" section of this manual.	
Bungee Cord	Check every hundred hours for correct tension and for signs of wear.	The Bungee Cord should last for many years. If a Bungee Cord change is required, please contact your local service representative or go online at www.lifefitness.com for further details.	
Rowing Belt	Check every hundred hours for correct tension and for signs of wear.	The Rowing Belt should provide many years of trouble free use. If a Rowing Belt change is required, please contact your local service representative or go online at www.lifefitness.com for further details.	

Water Treatment Procedure

Add one Water Treatment Tablet per full tank.

 **Note:** The amount of water treatment can vary widely depending on the rower's location and exposure to sunlight. **DO NOT, UNDER ANY CIRCUMSTANCES USE OTHER TREATMENT TABLETS OTHER THAN THOSE SUPPLIED WITH YOUR ROWER.**

Your rower box contents include 4x Water Treatment Tablets, which is sufficient for several years of water treatment. Treat when water becomes discolored or shows signs of Algae/Bacterial growth. To purchase additional Water Treatment Tablets, please consult your nearest regional dealer/distributor or check our website at www.lifefitness.com

Long Term Water Treatment

Do not use any water treatment other than the tablets supplied with this rower. For replacement tablets, contact [Cybex Customer Service](#). Water treatment schedules for the Life Fitness Row CX Trainer will vary according to the fluid tanks exposure to sunlight, but expect 8-12 months near a bright, sunlit window and 2 years or more for a darker location. At the point of finding the water slightly cloudy, add a chlorine Tablet.

 **Caution:** It is recommended that a drop cloth be used under the fluid tank whenever the tank is open for water treatment.

 **Caution:** Do not fill past the calibration mark as indicated on the tank level sticker or water spillage can occur.

Troubleshooting

Fault	Probable Cause	Solution
Water changes color or becomes cloudy.	Rower is in direct sunlight or has not had water treatment.	Change rower location to reduce direct exposure to sunlight. Add 1x Water Treatment Tablet or change tank water as directed in the water treatment section of this manual.

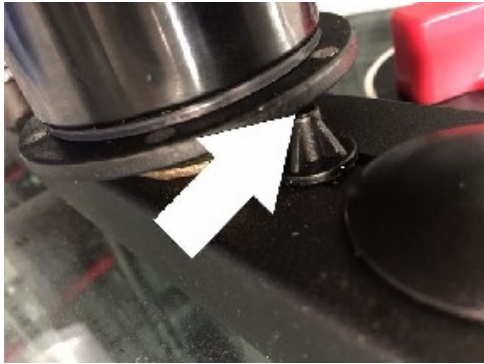
Fault	Probable Cause	Solution
Rowing stroke return too light.	Bungee not under enough tension.	Tighten by small increments using the bungee tie off tab point and test tension by allowing the rowing handle to return to its furthest point forward while still having some slight tension. Note: Light fraying of the bungee cord is normal.
Computer screen illuminates, but does not register when rowing.	Loose or failed connection/Sensor gap too wide (see erratic computer display).	Check that the computer lead is connected properly. If connected properly check sensor gap. Contact your local service center if this fails to address the problem.
The Row CX Trainer computer does not illuminate after battery installation.	Batteries installed incorrectly or need replacing.	Reinstall batteries in correct position and try again. If the LCD screen fails to illuminate, try rotating the batteries slightly in the computer. If this fails, contact your local service center.
The Row CX Trainer computer display is erratic while displaying SPM and 500 meter times.	Gap between sensor and magnetic ring is too wide.	Adjust sensor location using rear sliding adjustment located near timing pulley. 

5. Warranty

What is Covered

This LIFE FITNESS commercial exercise equipment Product is warranted to be free of all defects in material and workmanship.

Who is Covered

The original purchaser or any person receiving the product as a gift from the original purchaser.

How Long is it Covered

Residential: All electrical and mechanical components and labor are covered, after the date of purchase, as listed on the chart below. Non-Residential: Warranty void (the Row CX Trainer is intended for residential use only).

Structural Frame (Not coatings)	Tank	Mechanical	Labor	All other
5 Years	3 Years	2 Years	1 Year	1 Year

Who Pays Shipping and Insurance for Service

If the Product or any warranted part must be returned to a service facility for repairs, Life Fitness will pay all shipping and insurance charges during the warranty period (within the United States only). The purchaser is responsible for shipping and insurance charges after the warranty has expired.

What We Will Do To Correct Covered Defects

We will ship to you any new or rebuilt replacement part or component, or at our option, replace the Product. Such replacement parts are warranted for the remaining portion of the original warranty period.

What is Not Covered

Any failures or damage caused by unauthorized service, misuse, accident, negligence, improper assembly or installation, debris resulting from any construction activities in the Product's environment, rust or corrosion as a result of the Product's location, alterations or modifications without our written authorization, or by failure on your part to use, operate and maintain the Product as set out in your Operation Manual.

All terms of this warranty are void if this product is moved beyond the continental borders of the United States of America (excluding Alaska, Hawaii and Canada) and are then subject to the terms provided by that country's local authorized Life Fitness representative.

What You Must Do

Retain proof of purchase. use, operate and maintain the Product as specified in the Manual; notify the place of purchase of any defect within 10 days after discovery of the defect; if instructed, return any defective part for replacement or, if necessary, the entire Product for repair. Life Fitness reserves the right to decide whether or not a product is to be returned for repair.

User Manual

It is VERY IMPORTANT THAT YOU READ THE MANUAL before operating the Row CX Trainer. Remember to perform the periodic maintenance requirements specified in the Manual to assure proper operation and your continued satisfaction.

Product Registration

Register online at www.lifefitness.com/home/product-registration.html. Our receipt assures that your name, address and date of purchase are on file as a registered owner of the Product. Being a registered owner assures coverage in the event you lose your proof of purchase. Please retain your proof of purchase, such as your bill of sale or receipt.

How to get Parts and Service

Refer to the Corporate Headquarters section of this manual for your local service contact information. Reference your name, address and the serial number of your Product (consoles and frames may have different serial numbers). They will tell you how to get a replacement part, or, if necessary, arrange for service where your Product is located.

Exclusive Warranty

THIS LIMITED WARRANTY IS IN LIEU OF ALL OTHER WARRANTIES OF ANY KIND EITHER EXPRESSED OR IMPLIED, INCLUDING BUT NOT LIMITED TO THE IMPLIED WARRANTIES OF MERCHANTABILITY AND FITNESS FOR A PARTICULAR PURPOSE, AND ALL OTHER OBLIGATIONS OR LIABILITIES ON OUR PART. We neither assume nor authorize any person to assure for us any other obligation or liability concerning the sale of this Product. Under no circumstances shall we be liable under this warranty, or otherwise, of any damage to any person or property, including any lost profits or lost savings, for any special, indirect, secondary, incidental or consequential damages of any nature arising out of the use of or inability to use this Product. Some states do not allow the exclusion or limitation of implied warranties or of liability for incidental or consequential damages, so the above limitations or exclusions may not apply to you. Warranty coverages and terms may differ outside the United States. Please contact the Life Fitness office servicing your country (contact information found at the front of this manual) or visit the applicable local Life Fitness website to receive the specific warranty information for your country.

Changes in Warranty Not Authorized

No one is authorized to change, modify or extend the terms of this limited warranty.

Effects of State Laws

This warranty gives you specific legal rights, and you may have other rights which vary from state to state and country by country.