

TOTAL BODY EXERCISER

MACHINE OWNER'S MANUAL



ALL PRO2 SERIES MODELS

A6780 REV CC



Prescribed for Progress™

Corporate Headquarters

Columbia Centre III, 9525 Bryn Mawr Avenue, Rosemont, IL 60018 • U.S.A.
847.288.3300 • FAX: 847.288.3703
Service phone number: 800.351.3737 (toll-free within U.S.A., Canada)
Global Website: www.lifefitness.com

International Offices

AMERICAS

North America

SCIFIT

Columbia Centre III
9525 Bryn Mawr Avenue
Rosemont, IL 60018 U.S.A.
Telephone: (847) 288 3300
Email: Service@scifit.com
Service Website: www.scifit.com/service-information

Brazil

Life Fitness Brasil

Av. Rebouças, 2315
Pinheiros
São Paulo, SP 05401-300
BRAZIL
SAC: 0800 773 8282 option 2
Telephone: +55 (11) 3095 5200 option 2
Service Email: suportebr@lifefitness.com
Sales/Marketing Email:
vendasbr@lifefitness.com

Latin America and Caribbean*

Life Fitness, LLC

Columbia Centre III
9525 Bryn Mawr Avenue
Rosemont, IL 60018 U.S.A.
Telephone: (847) 288 3300
Service Email:
customersupport@lifefitness.com
Sales/Marketing Email:
commercialsales@lifefitness.com

EUROPE, MIDDLE EAST, and AFRICA (EMEA)

Belgium, Netherlands, and Luxemburg

Life Fitness Atlantic BV

Bijdorpplein 25-31
2992 LB Barendrecht
THE NETHERLANDS
+3118064666
Service Email:
service.benelux@lifefitness.com
Sales/Marketing Email:
marketing.benelux@lifefitness.com

United Kingdom

Life Fitness UK LTD

Unit 109^a
Lancaster Way Business Park
Ely, Cambs, CB6 3NX
Telephone: General Office (+44)
1353.666017
Customer Support (+44) 1353.665507
Service Email: uk.support@lifefitness.com
Sales/Marketing Email: life@lifefitness.com

Germany, Austria, and Switzerland

Life Fitness Europe GMBH

Neuhofweg 9
85716 Unterschleißheim
GERMANY
Telephone:
+49 (0) 89 / 31775166 Germany
+43 (0) 1 / 6157198 Austria
+41 (0) 848 / 000901 Switzerland
Service Email:
kundendienst@lifefitness.com
Sales/Marketing Email:
vertrieb@lifefitness.com

Spain

Life Fitness IBERIA

C/Frederic Mompou 5,1^a
08960 Sant Just Desvern Barcelona
SPAIN
Telephone: (+34) 93.672.4660
Service Email:
servicio.tecnico@lifefitness.com
Sales/Marketing Email:
info.iberia@lifefitness.com

All Other EMEA Countries and Distributor Business EMEA*

Life Fitness Atlantic BV

Bijdorpplein 25-31
2992 LB Barendrecht
THE NETHERLANDS
+3118064666
Service Email:
emeaservicesupport@lifefitness.com

ASIA PACIFIC (AP)

Japan

Life Fitness Japan, Ltd

4-17-33 Minami Aoyama 1F/B1F
Minato-ku - Tokyo 107-0062
Japan
Telephone: (+81) 0120.114.482
Fax: (+81) 03-5770-5059
Service Email: service.lfj@lifefitness.com
Sales/Marketing Email:
sales@lifefitnessjapan.com

Hong Kong

Life Fitness Asia Pacific LTD

26/F, Global Trade Square
21 Wong Chuk Hang Road
Wong Chuk Hang
Hong Kong
Telephone: (+852) 25756262
Fax: (+852) 25756894
Service Email: service.hk@lifefitness.com
Sales/Marketing Email:
marketing.hk.asia@lifefitness.com

All Other Asia Pacific countries and distributor business Asia Pacific*

Life Fitness Asia Pacific LTD

26/F, Global Trade Square
21 Wong Chuk Hang Road
Wong Chuk Hang
Hong Kong
Telephone: (+852) 25756262
Fax: (+852) 25756894
Service Email: service.ap@lifefitness.com
Sales/Marketing Email:
marketing.hk.asia@lifefitness.com

*Also check www.SCIFIT.com for local representation or distributor/dealer

* Order online 24/7 at www.SCIFIT.com

User and Service Documents Link

<https://fn.fit/KnowledgeBase>

<https://fn.fit/SupportDocuments>

Additional information is available online using the links above.

تتوفر معلومات إضافية على الإنترنت باستخدام الرابط أعلاه.

点击上面的链接可在线获取更多信息。

Flere oplysninger er tilgængelige online gennem linket ovenfor.

Bijkomende informatie is online beschikbaar via bovenstaande link.

Vous trouverez plus d'informations en ligne à l'aide du lien ci-dessus.

Zusätzliche Informationen finden Sie online über den oben angegebenen Link.

Ulteriori informazioni sono disponibili online utilizzando il link sopra riportato.

追加情報は上記リンクを使用してオンラインで利用可能です。

상기 링크를 통해 온라인에서 추가 정보를 볼 수 있습니다.

Informações adicionais estão disponíveis on-line, através do link acima.

Дополнительная информация доступна в интернете по ссылке, указанной выше.

Mediante el enlace anterior podrá acceder a información adicional en línea.

Ytterligare information finns online genom att använda länken ovan.

İnternet üzerinden daha fazla bilgi edinmek için yukarıdaki bağlantıyı kullanabilirsiniz.

هناك معلومات إضافية متاحة على الإنترنت باستخدام الرابط أعلاه.

Informazio osagarria eskuragarri dago goiko estekaren bidez.

Допълнителна информация можете да намерите онлайн, като използвате връзката по-горе.

Mitjançant l'enllaç anterior podreu accedir a informació addicional en línia.

使用上面的連結線上提供額外資訊。

Dodatne informacije možete pronaći na internetu sljedeći vezu iznad.

ከላይ የተመጠውን አገናኝ(ሊንክ) በመጠቀም መረጃዎች አንላይን ያገኛሉ።

Lisätietoja on saatavissa verkosta käyttämällä yllä olevaa linkkiä.

Wubetumi anya nsem afoforo aka ho wo websait so denam asem a ewo atifi ho a wubemia so so.

Πρόσθετες πληροφορίες είναι διαθέσιμες online χρησιμοποιώντας το σύνδεσμο παραπάνω.

מידע נוסף אפשר לקבל באינטרנט באמצעות הקישור לעיל.

További információ elérhető online, a fenti hivatkozás segítségével.

Viðbótarupplýsingar eru fáanlegar á netinu með því að smella á tengilinn hér fyrir ofan.

Plus indicium per superum situm potes invenire.

മുകളിലുള്ള ലിങ്ക് ഉപയോഗിച്ച് ഓൺലൈനിൽ കൂടുതൽ വിവരങ്ങൾ ലഭ്യമാണ്.

Ytterligere informasjon er tilgjengelig på nettet via linken ovenfor.

Dodatkowe informacje są dostępne online pod powyższym odnośnikiem.

Informações adicionais estão disponíveis online a usar o link acima.

Informații suplimentare sunt disponibile online, utilizând link-ul de mai sus.

Dodatne informacije dostupne su na mreži putem gornjeg linka.

Ďalšie informácie sú dostupné online na vyššie uvedenom odkaze.

Table of Contents

Safety

Introduction.....	6
Safety Information.....	6

Product Overview

Product Overview.....	8
-----------------------	---

Service and Technical Data

Maintenance.....	9
------------------	---

Assembly and Relocation

PRO2 Assembly.....	10
PRO2 Relocate.....	18

Adjustments

Machine Start-up.....	20
Low Starting Resistance Information.....	21
Console Adjustment.....	22
Upper Crank Adjustment.....	23
Lower Crank Adjustment.....	24

Biomechanical Positioning

Machine Entry.....	25
Initiating a Workout.....	25
Exit the Machine.....	25

Specifications

Specifications.....	26
---------------------	----

Warranty

What is Covered.....	27
Who is Covered.....	27
How Long it is Covered.....	27
Who Pays Transportation and Insurance For Service.....	27
What We Will Do To Correct Covered Defects.....	27
What is Not Covered.....	27
What You Must Do.....	27
How to Get Parts and Service.....	27
Exclusive Warranty.....	27
Changes in Warranty Not Authorized.....	28
Effects of State Laws.....	28
Terms of Warranty Coverage.....	28

1. Safety

Introduction

Thank you for your purchase of this SCIFIT exercise machine. We have incorporated the finest technology and ergonomic design into this machine to assist you in achieving your fitness goals.

To review the latest guidelines and recommendations, visit the American College of Sports Medicine website: www.acsm.org

FCC Warning - Possible Radio / Television Interference

This equipment has been tested and found to comply with the limits for a Class A digital device, pursuant to part 15 of the FCC rules. These limits are designed to provide reasonable protection against harmful interference when the equipment is operated in a commercial environment. This equipment generates, uses and can radiate radio frequency energy, and if not installed and used in accordance with the instruction manual, may cause harmful interference to radio communications. Operation of this equipment in a residential area is likely to cause harmful interference in which case the user will be required to correct the interference at his own expense.

Safety Information

- ⚠ **DANGER:** To reduce the risk of electrical shock or injury from moving parts, always unplug the machine before cleaning or attempting any maintenance activity.
 - ⚠ **WARNING:** Health-related injuries may result from incorrect or excessive use of exercise equipment. It is STRONGLY recommended seeing a physician for a complete medical exam before undertaking an exercise program, particularly if the user has a family history of high blood pressure or heart disease, is over the age of 45, smokes, has high cholesterol, is obese, or has not exercised regularly in the past year. If, at any time while exercising, the user experiences faintness, dizziness, pain, or shortness of breath, he or she must stop well immediately.
 - ⚠ **WARNING:** To reduce the risk of burns, fire, electrical shock, or injury, it is imperative to connect each product to a properly grounded electrical outlet.
 - ⚠ **WARNING:** Heart rate monitoring systems may be inaccurate. Over exercising may result in serious injury or death. If you feel faint, stop exercising immediately.
 - ⚠ **WARNING:** Allow a distance of 40 in. (1m) between the widest part of the machine and other objects on either side. Provide 40 in (1m) between the front or rear of the SCIFIT machine to any other objects.
 - ⚠ **WARNING:** This product can expose you to chemicals including Ethylbenzene, which is known to the State of California to cause cancer, and Toluene, which is known to the State of California to cause birth defects or other reproductive harm. For more information go to <http://www.P65Warnings.ca.gov>
 - ⚠ **CAUTION:** Any changes or modifications to this equipment could void the product warranty.
- Life Fitness does not warrant nor guarantee that component parts used in the manufacture of products offered under the Life Fitness are latex-free. Users of these products must take all necessary precautions to prevent accidental contact that could lead to an adverse latex reaction.
 - Read all warnings and instructions on each product prior to using your exercise machine. Save these instructions for future reference.
 - If warnings are missing or damaged, please contact customer service immediately for replacement warning labels. Warning labels are shipped with every product and should be installed before the product is used. SCIFIT is not responsible for missing or damaged warning labels.
 - Use the exercise machine only for its intended purposes as described in this manual. Do not use attachments not recommended by the manufacturer.
 - Never insert objects into any opening in these products. If an object should drop inside, turn off the power, unplug the power cord from the outlet, and carefully retrieve it. If the item cannot be reached, contact customer support services..
 - This machine is intended for indoor use only. Do not place in direct sunlight, high humidity or where water is present (i.e. pool or spa areas).
 - This machine is not intended for use by persons with reduced physical sensory or mental capabilities, or lack of experience and knowledge, unless they have been given supervision or instruction concerning use of the machine by a person responsible for their safety. Keep children under the age of 14 away from this machine.
 - Never operate the machine with the air openings blocked. Keep air openings free of lint, hair, or any other obstructing material.
 - Never place liquids of any type directly on the unit, except in an accessory tray or holder. Containers with lids are recommended. Do not use these products in bare feet. Always wear shoes. Wear shoes with rubber or high-traction soles. Do not use shoes with heels, leather soles, cleats or spikes. Make sure no stones are embedded in the soles.
 - Keep all loose clothing, shoelaces, and towels away from moving parts.

- Do not reach into, or underneath, the unit or tip it on its side during operation.
- Do not allow other people to interfere in any way with the user or equipment during a workout.
- When the product is not in use, SCIFIT recommends unplugging the product. Disconnect from the electrical outlet when not in use, and before putting on or taking off parts.
- Free standing equipment shall be installed on a stable and leveled surface.
- Do not stand or sit on plastic shrouds.
- Use caution when mounting or dismounting the machine. Use the stationary handlebar whenever additional stability is required.

Machine Safety Perimeter

PRO2

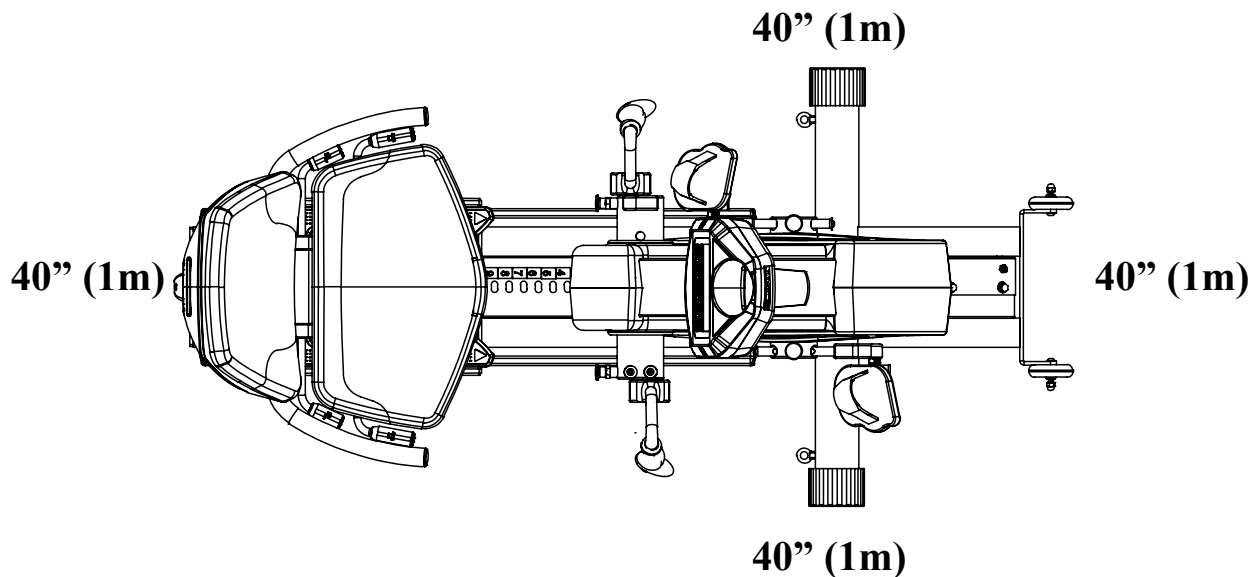

2. Product Overview

Product Overview

PRO2

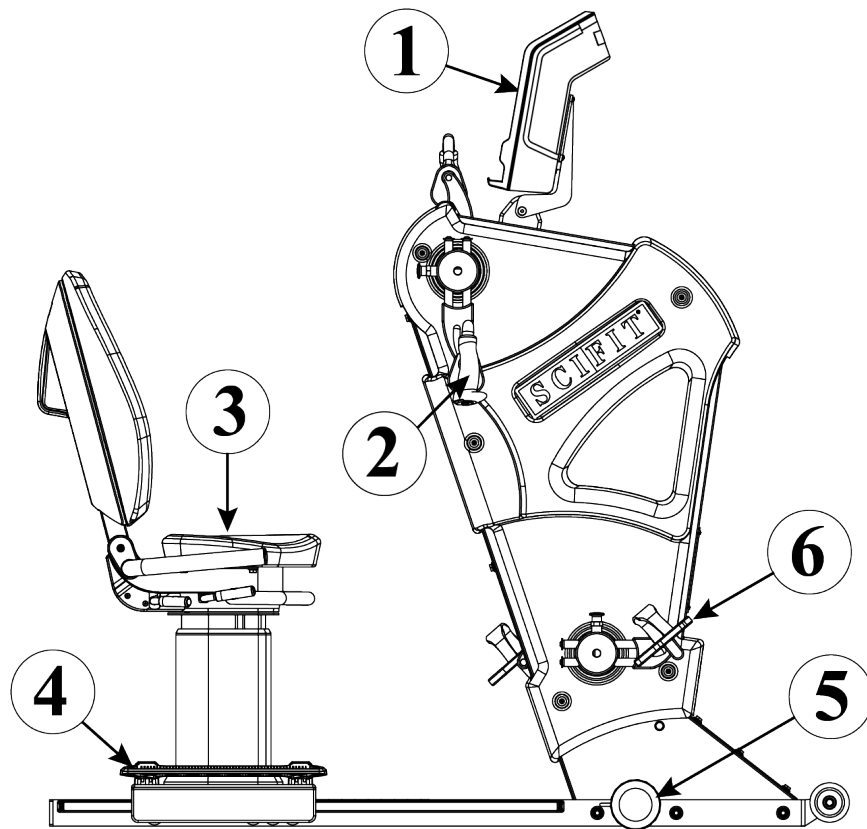

1	GEN4 Console
2	Adjustable Upper Cranks with Ergonomic Grips
3	Ergonomic Seat Assembly (Premium Seat Shown)
4	Forward/Backward Seat Adjustment Foot Lever
5	Leveling Endcaps
6	Adjustable Lower Foot Pedal Cranks

3. Service and Technical Data

Maintenance

Component	Action	When
Upholstery	Clean With a Damp Cloth	Daily
Base Roller Track	Clean With a Damp Cloth	Weekly
Battery	Refer to "Rotary CNSL Prog. Manual" For battery Check Instruct.	Monthly
Chain	General Purpose Chain Lubricant	Every 6 Mo.

ATTENTION: Contact your local waste management agency for specific requirements concerning recycling and disposal locations of batteries.

4. Assembly and Relocation

PRO2 Assembly

Short assembly steps will be required when the machine arrives at the customer location. The following steps will show these steps for the PRO2 machine models.

Tools Required:

- Torque wrench set 48 ft-lbs/65 Nm
- 12 in/30.5 cm Ratchet extension
- 5/16 in/8 mm Hex bit
- 12 in/30.5 mm Center Punch
- 5 mm Allen Hex bit
- Cordless drill or Ratchet
- Phillips Screw driver or bit

Parts Required:

- Washer, Flat 3/8" (Qty. 4)
- Washer, Split 3/8" (Qty. 4)
- Bolt, 3/8"-16 x 1" Socket (Qty. 4)
- Console to Quadrant mounting hardware (2 pcs.)
- Console to Console mounting bracket M5 x 12 mm black phillips screws (Qty. 4)

1. The PRO2 machine will arrive with two securing shipping brackets located on the front part of the frame. These brackets will need to be removed.

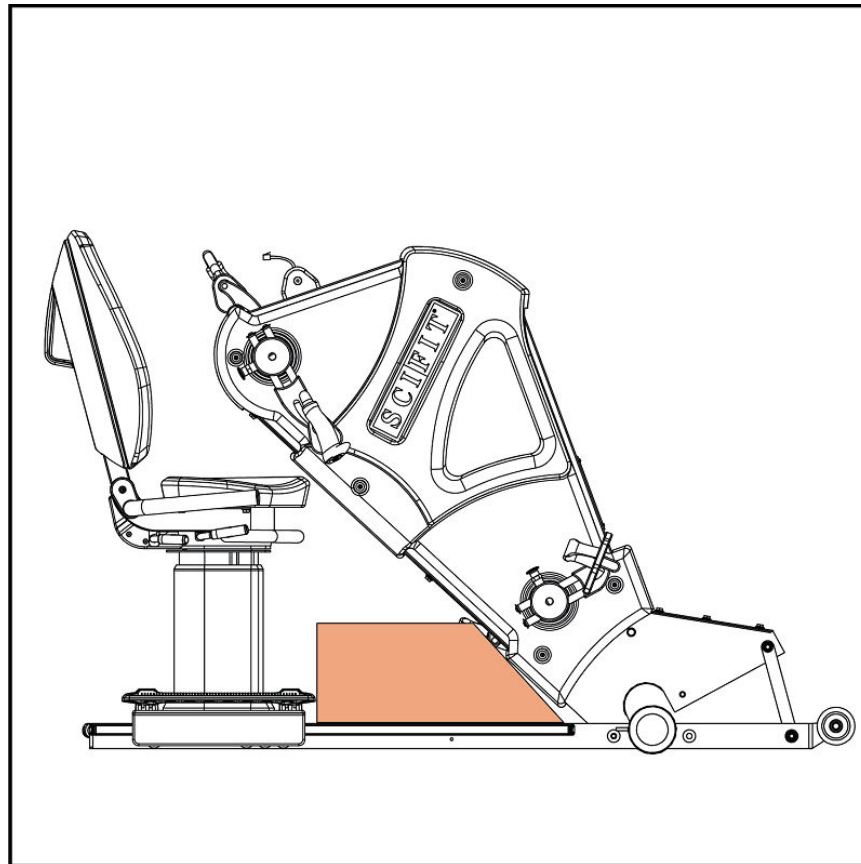

2. Use a 5/16" hex bit and ratchet or cordless drill to remove the top and bottom securing shipping hardware of both brackets as shown and place the hardware to the side for later use. **NOTE: At this time the metal shipping brackets may be disposed.**

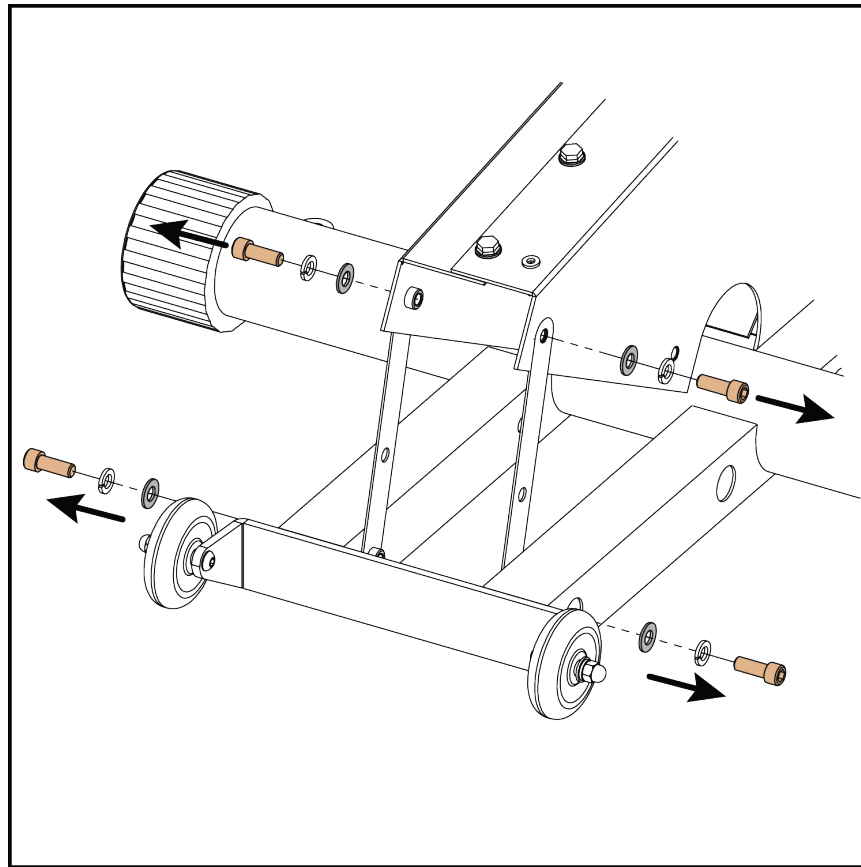

3. Stand up the main body of the PRO2, then remove any packaging that was on the machine. **NOTE: Use a 5/16" hex bit and ratchet to loosen the securing pivot hardware if needed.**

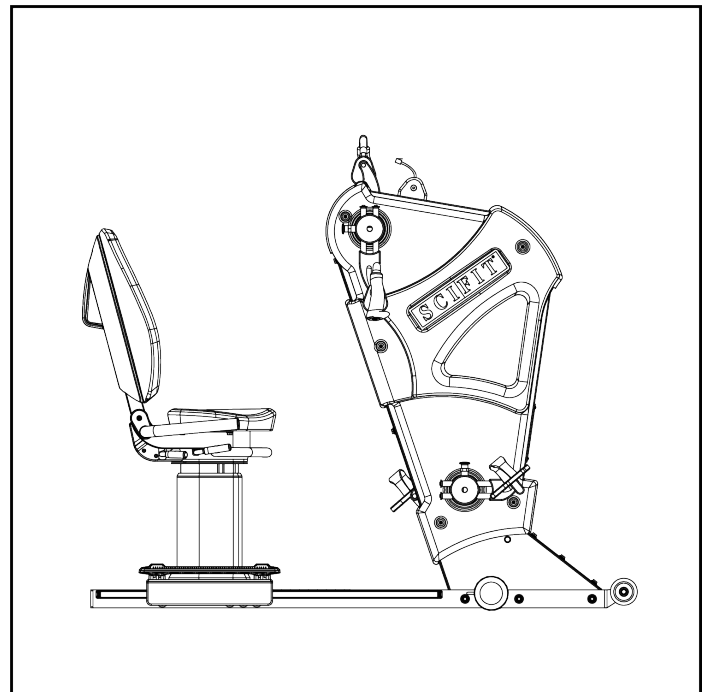
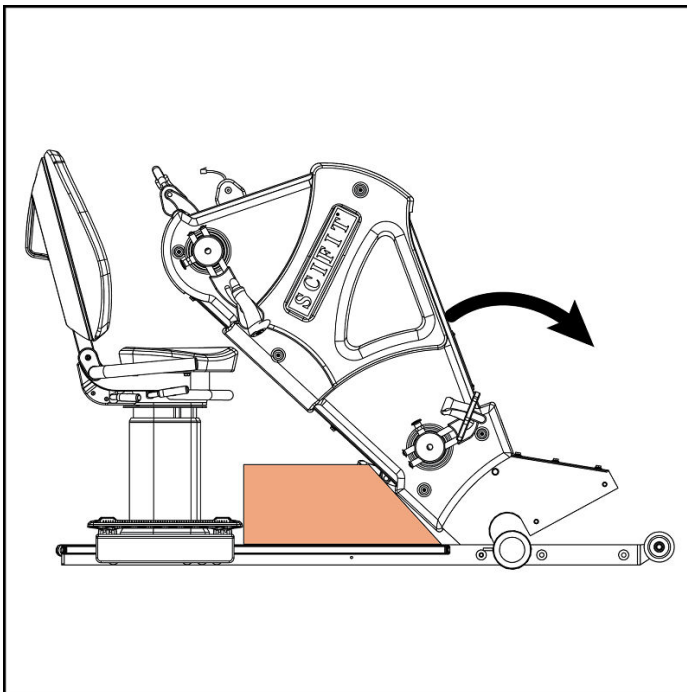

4. Starting on the right side, take the 12" center punch and insert it into the second hole from the front (nearest to the round tube).

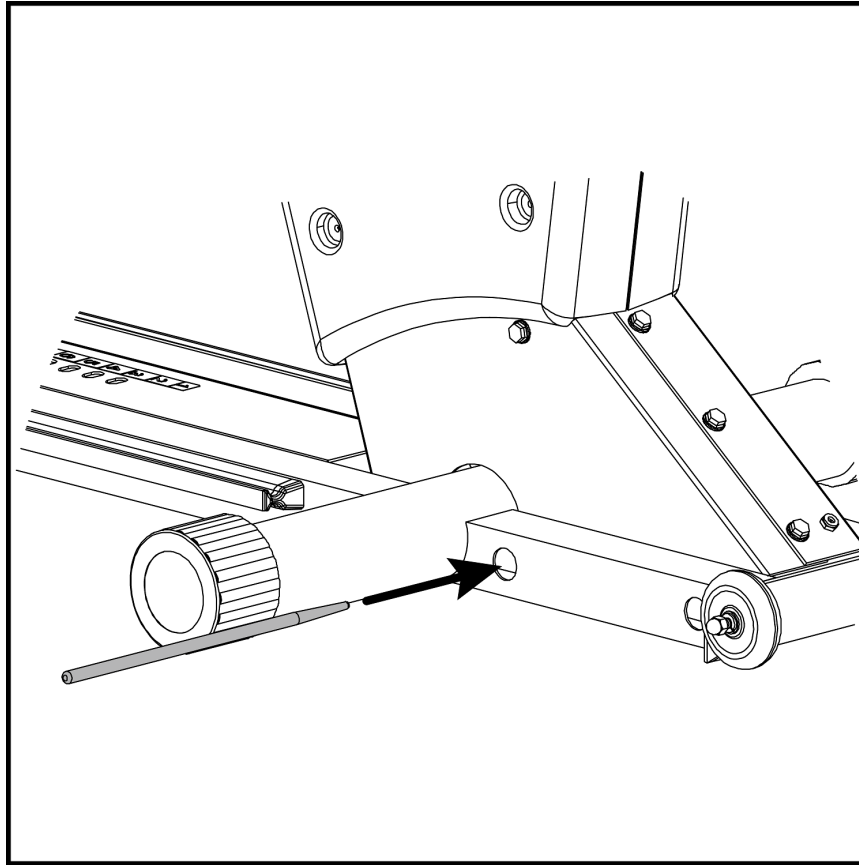

5. Attach a 5/16" hex bit to a 12" extension, then take a 3/8" bolt, 3/8" split washer and 3/8" flat washer from the shipping bracket hardware that was set aside and **loosely** insert the hardware into the front hole of the base frame closest to the transport wheels as shown.

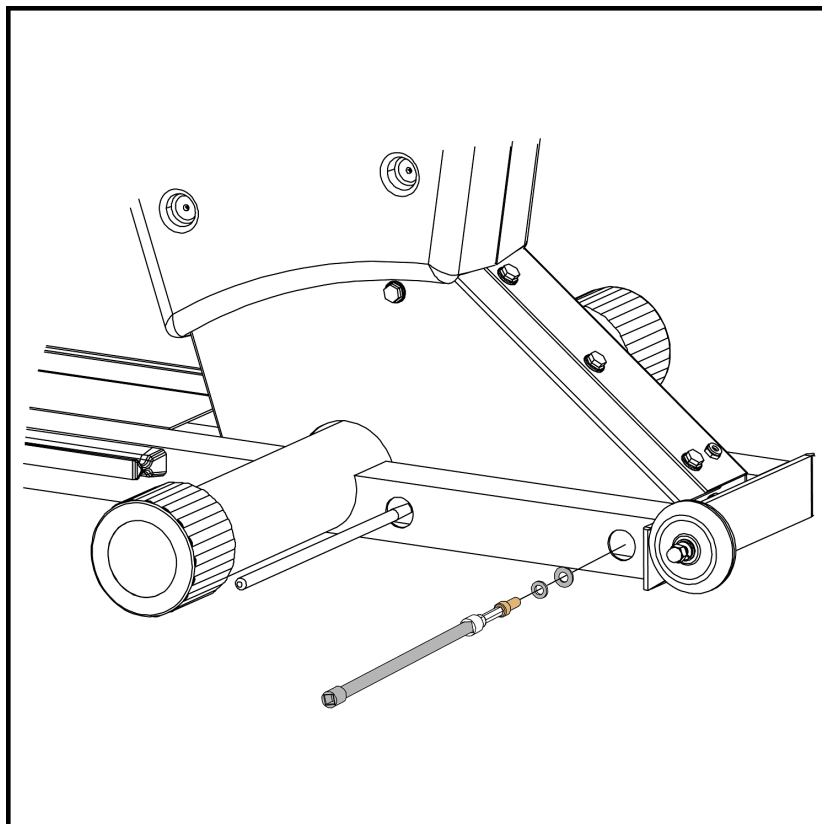

6. Remove the center punch , then again use the 12" extension with attached 5/16" hex bit and take a 3/8" bolt, 3/8" split washer and 3/8" flat washer, then **loosely** insert the hardware into the hole where the center punch was located.

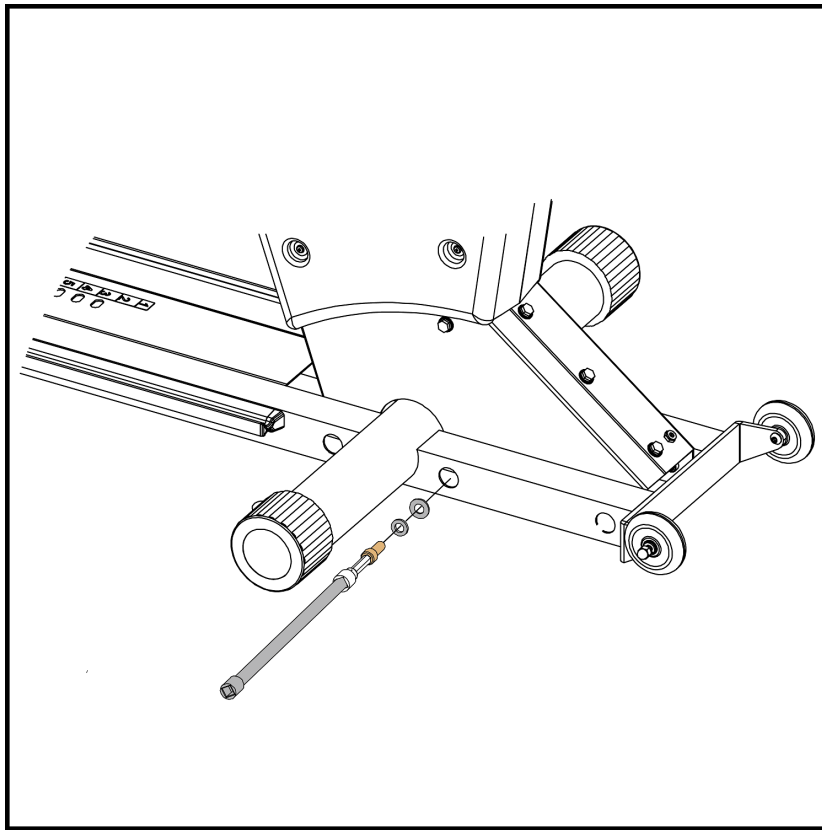

7. Go to the left side and use the 12" extension with attached 5/16" hex bit to **loosely** insert a 3/8" bolt, 3/8" split washer and 3/8" flat washer into the front hole of the base frame closest to the transport wheels as shown.

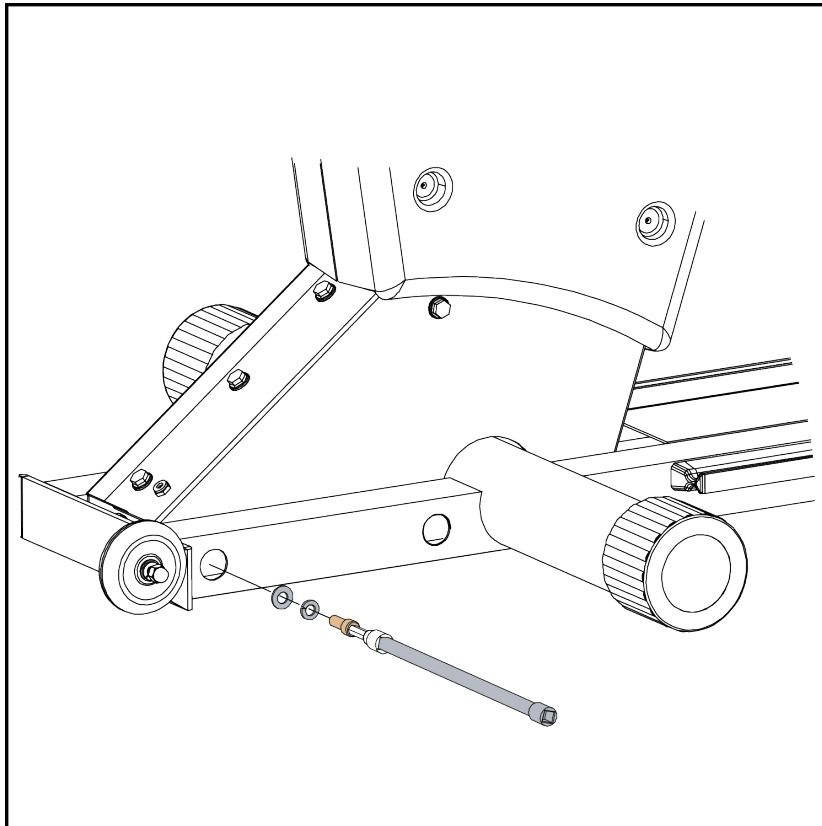

8. Finally take the 12" extension with attached 5/16" hex bit and **loosely** insert the last set of 3/8" bolt, 3/8" split washer and 3/8" flat washer into the hole closest to the round tube as shown.

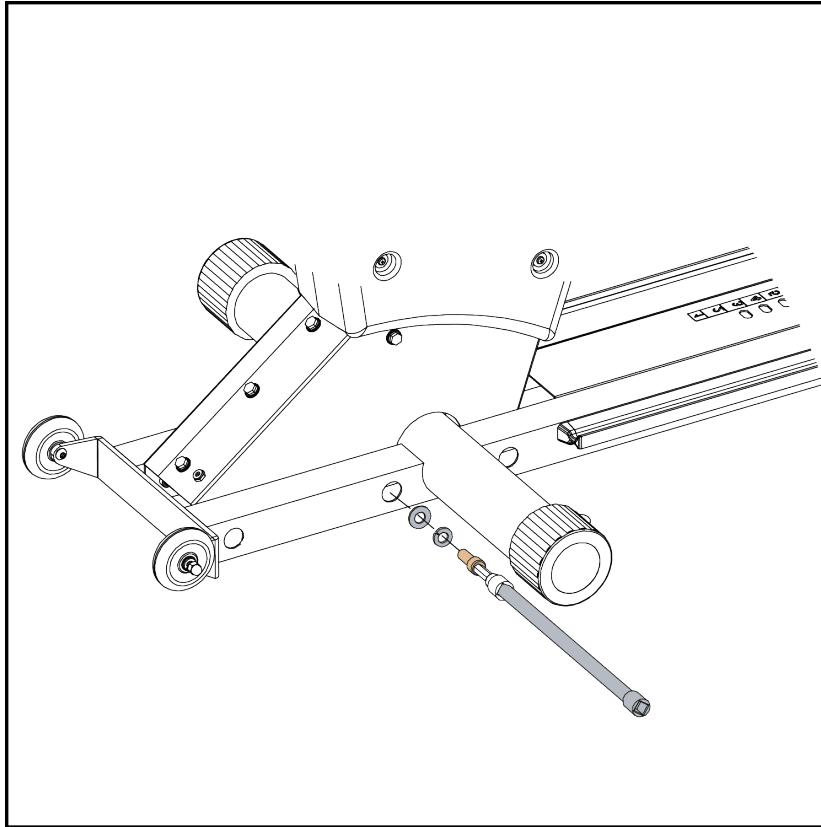

9. Starting on the left side take the torque wrench set at 48 ft-lbs/65 Nm, then attach the 12" extension and 5/16" hex bit. Tighten the main body to base frame hardware in the three holes.

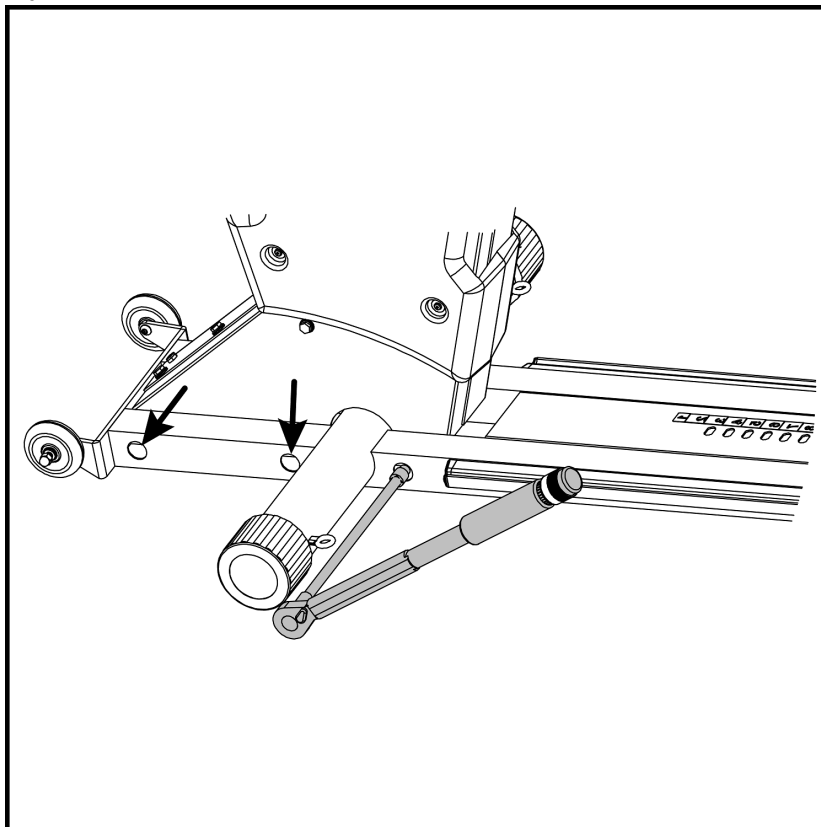

10. Repeat step 9 on the right side.

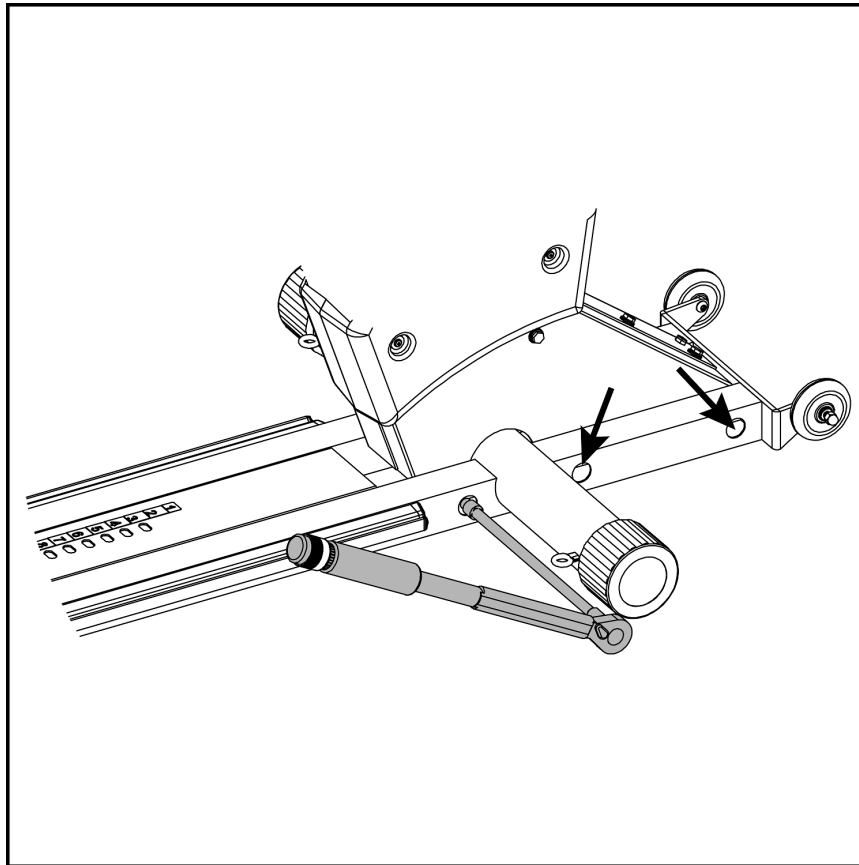

11. Go to the top of the machine and use (Qty. 2) 5 mm hex bits and ratchet or cordless drill to remove the console mounting bracket to quadrant hardware.

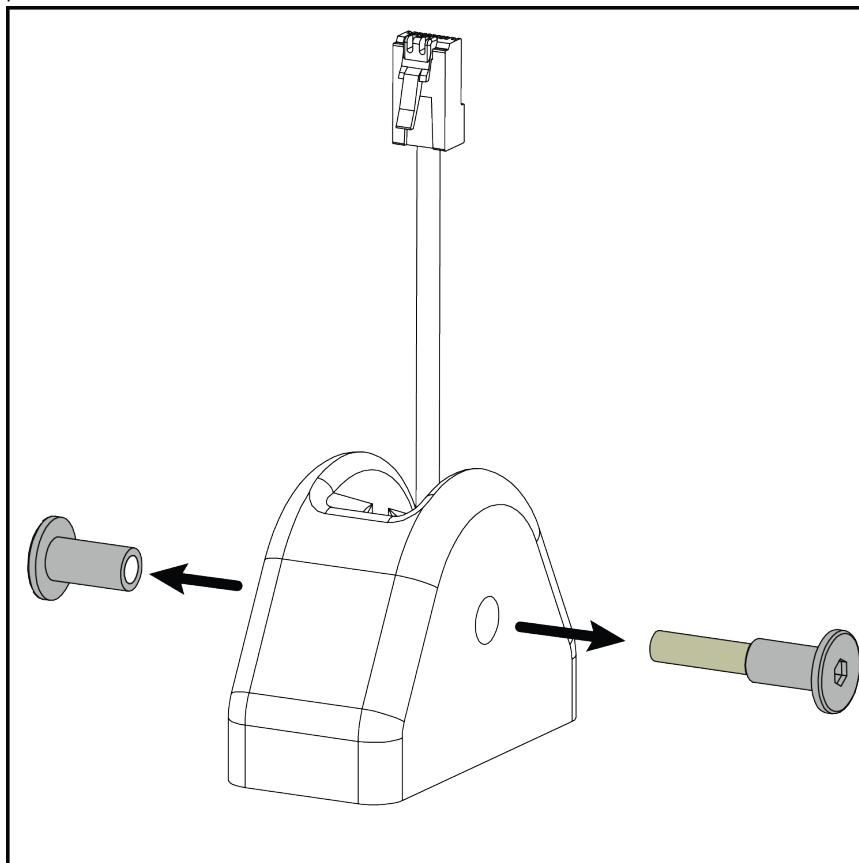

12. Align the holes of the console mounting bracket with the holes of the quadrant, then re-insert the console mounting bracket to quadrant hardware and secure with the 5 mm hex bits

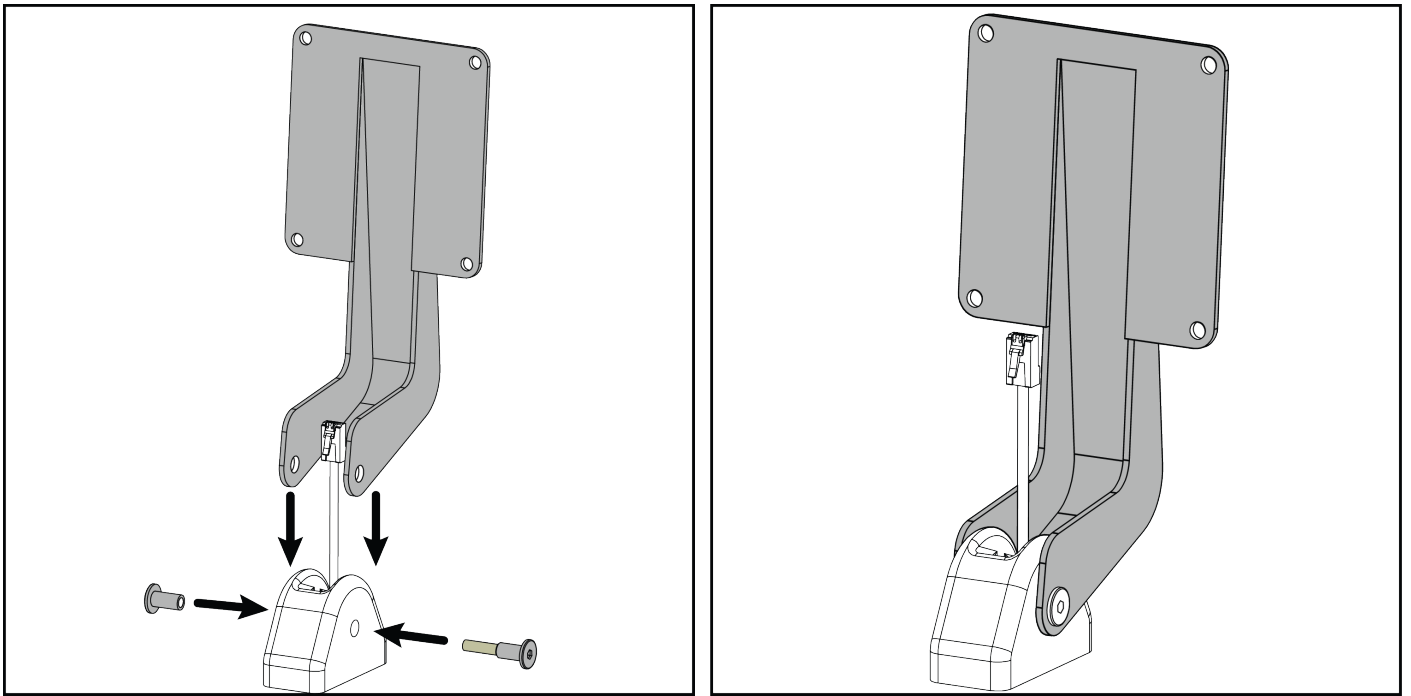

13. Connect the machine communication cable to the RJ45 connector at the rear of the console.

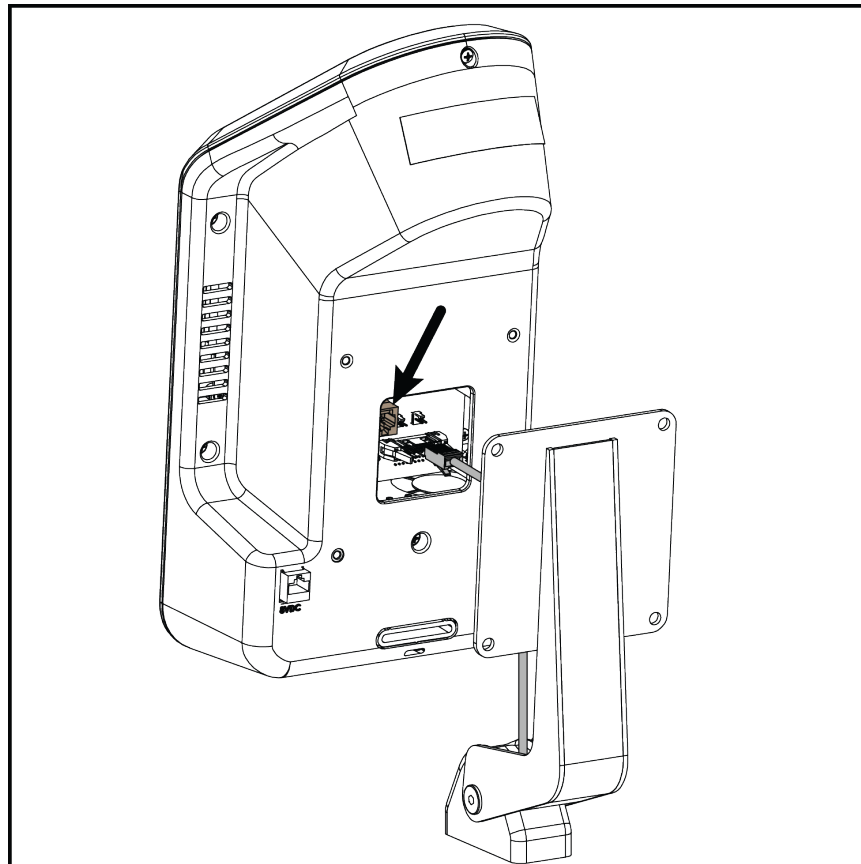

14. Align the mounting holes of the console and the mounting bracket, then use a phillips screw driver or bit to secure the console with (Qty. 4) M5 x 12 mm black phillips screws.

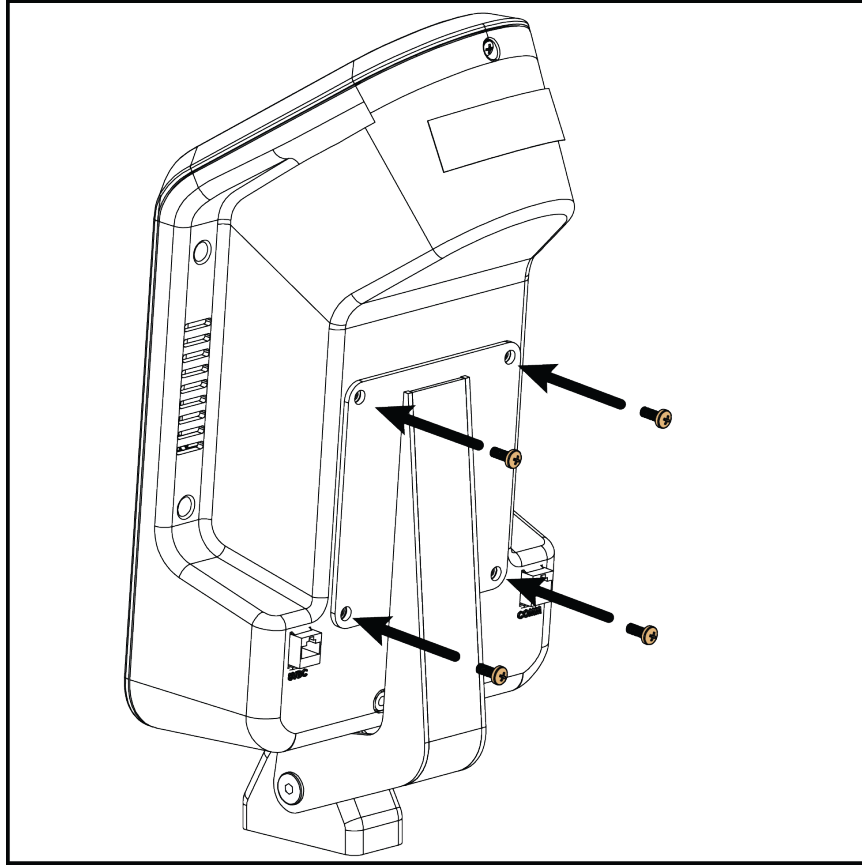

ASSEMBLY COMPLETE

PRO2 Relocate

1. Remove the seat by pressing down on either left or right yellow foot levers, then slide the seat assembly off the base frame and place to the side.

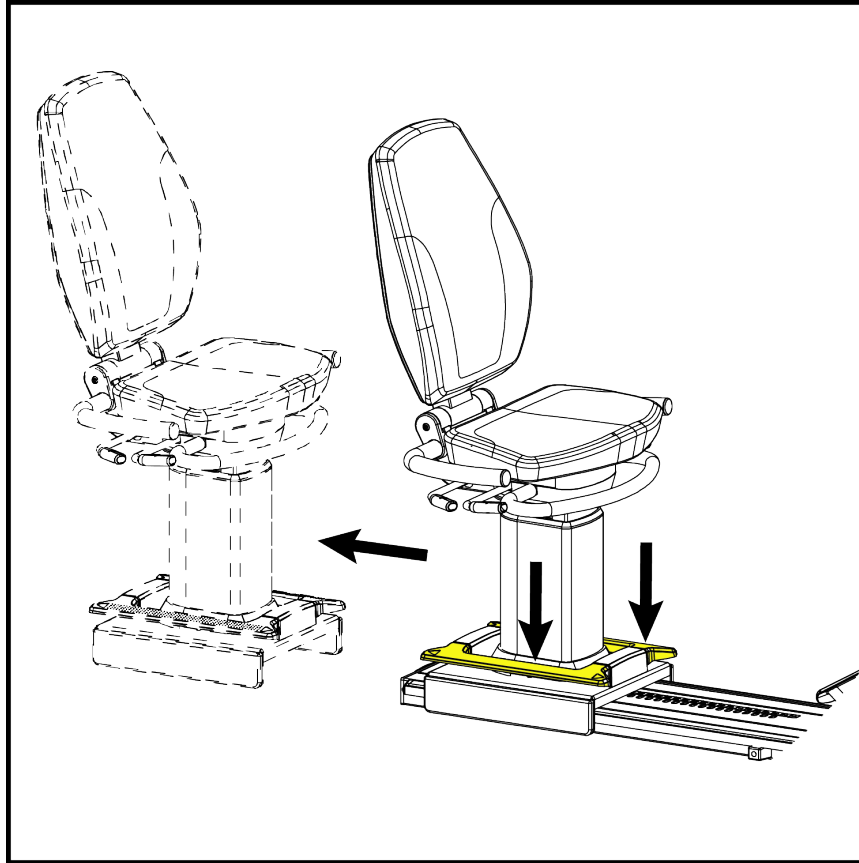

2. Grab the lift handle at the back of the base frame and lift until the front transport wheels touch the floor, then move the machine to the preferred location.

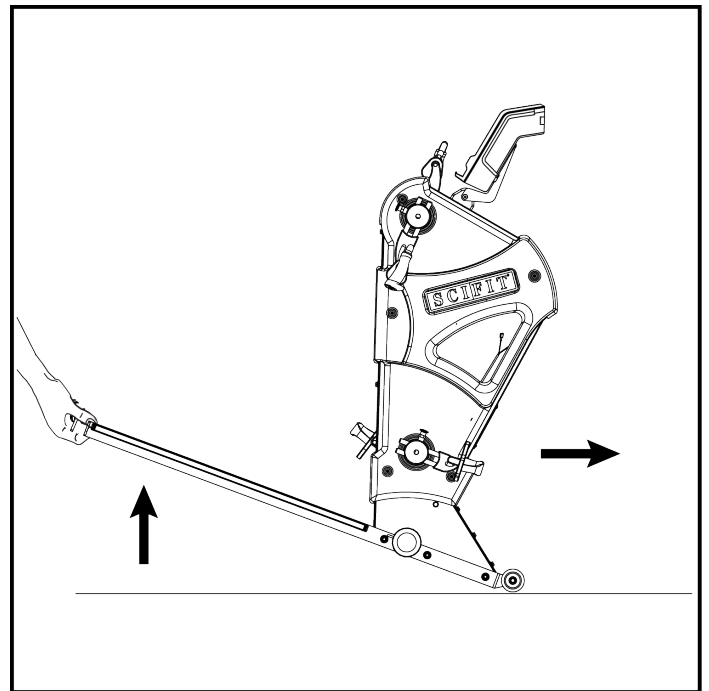
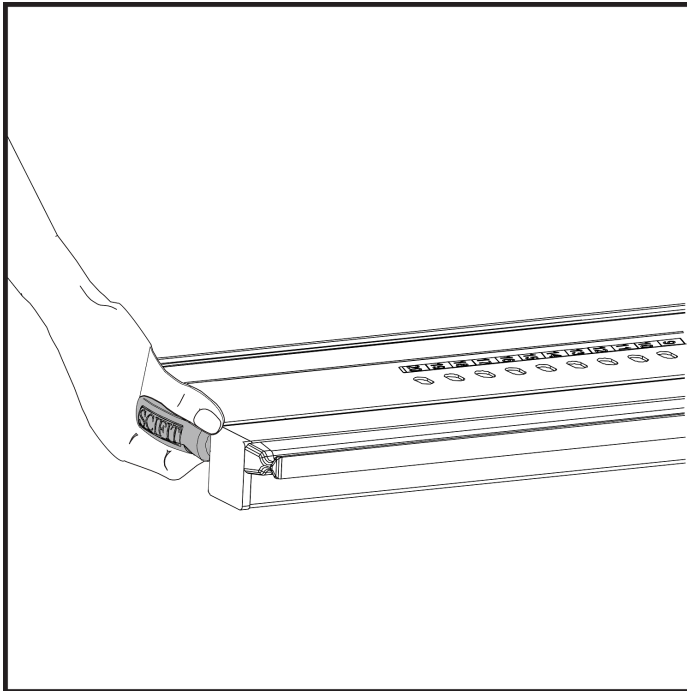

3. Once at the location, if needed adjust the left and right end caps to make the machine level with the floor.

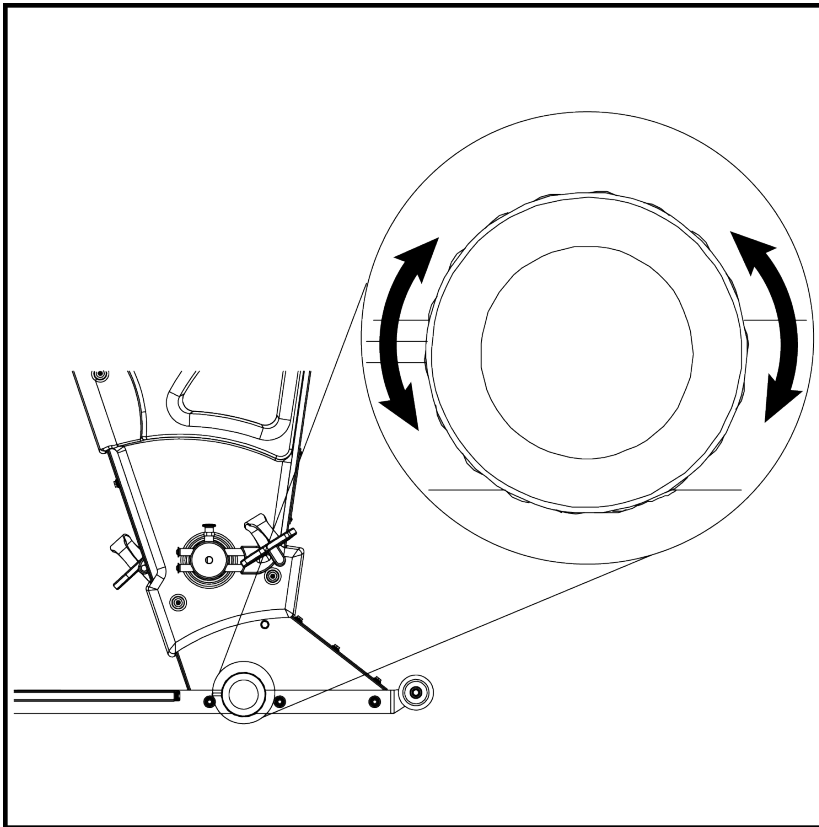

4. Remount the seat assembly by pressing either the left or right yellow foot levers, then slide the seat assembly onto the base frame and release the foot lever at the preferred position.

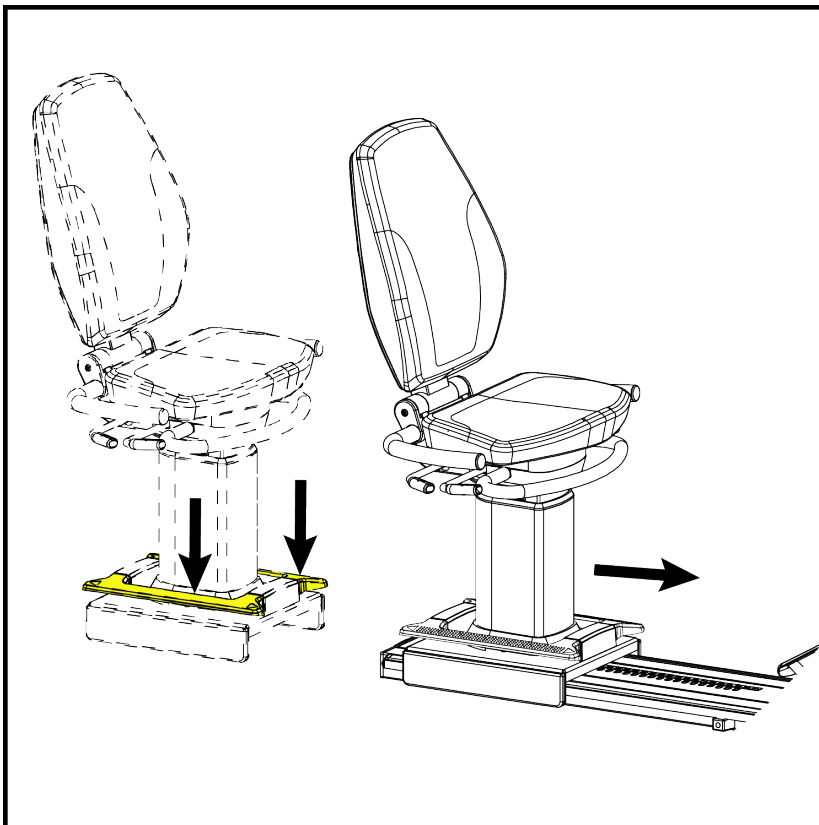

RELOCATION COMPLETE

5. Adjustments

Machine Start-up

There are two ways to activate the console screen to begin a workout.

Turn either the upper or lower cranks to activate the console.

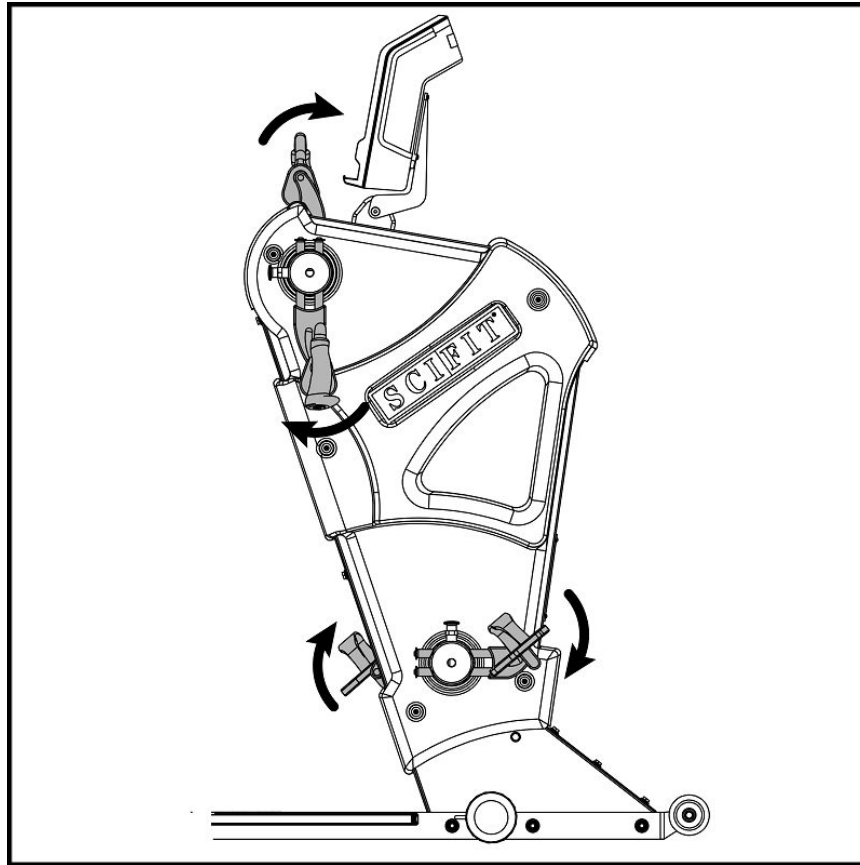

Connect the wallpack to the machine.

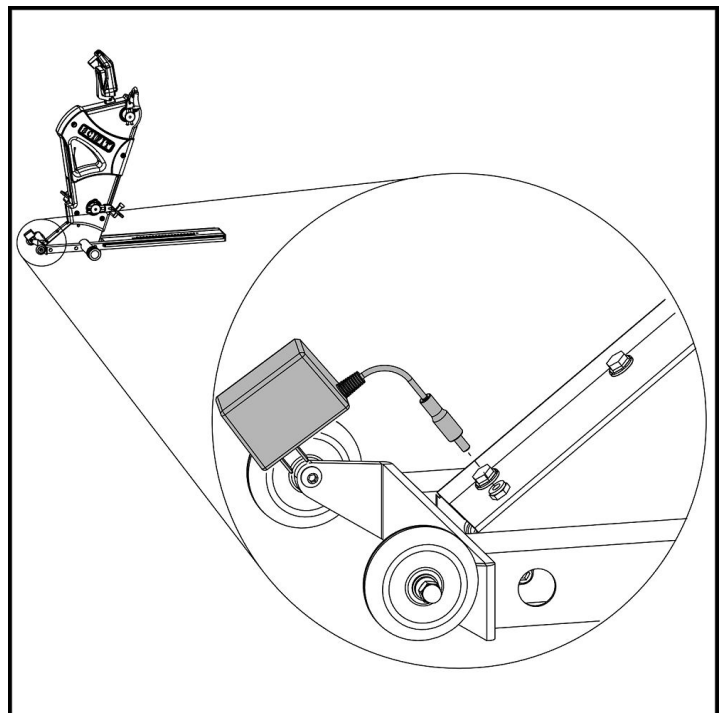
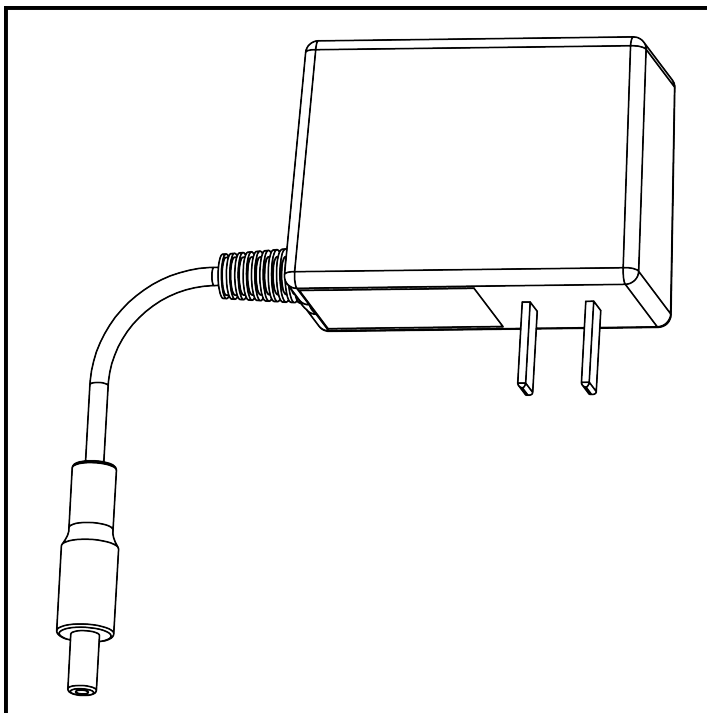

Low Starting Resistance Information

In facilities where the lowest possible starting resistance is desired, please use the enclosed, UL Approved, 18 volt adapter (#P4861) to plug your SCIFIT product into an electrical outlet. While all SCIFIT products provide low starting resistance, the use of the 18 volt adapter makes a noticeable difference in lowering the starting resistance.

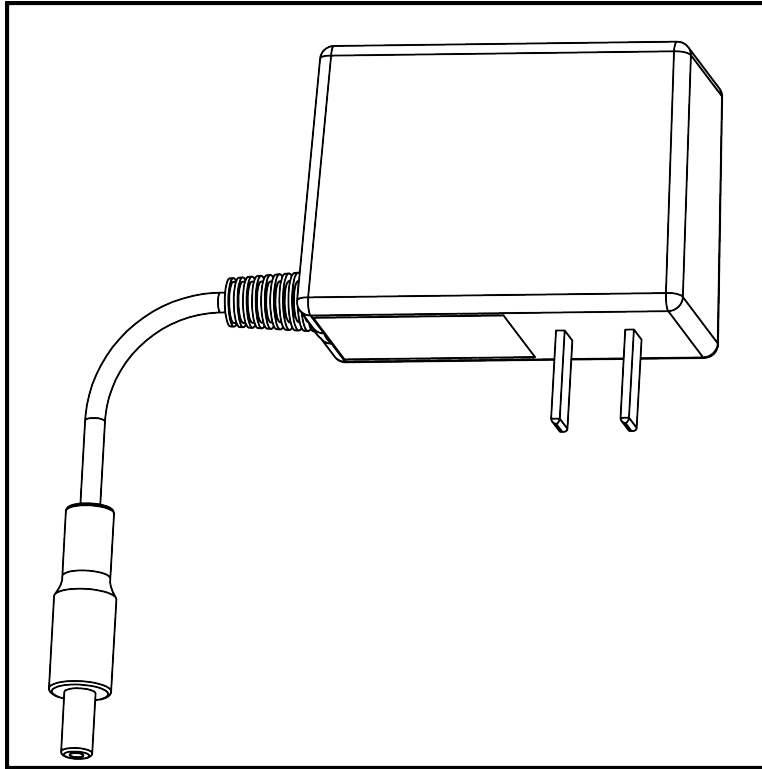

AC adapter extensions (#P4669) are available to order from our parts department. This adds 6 feet to the existing 6 foot cord on your adapter.



Console Adjustment

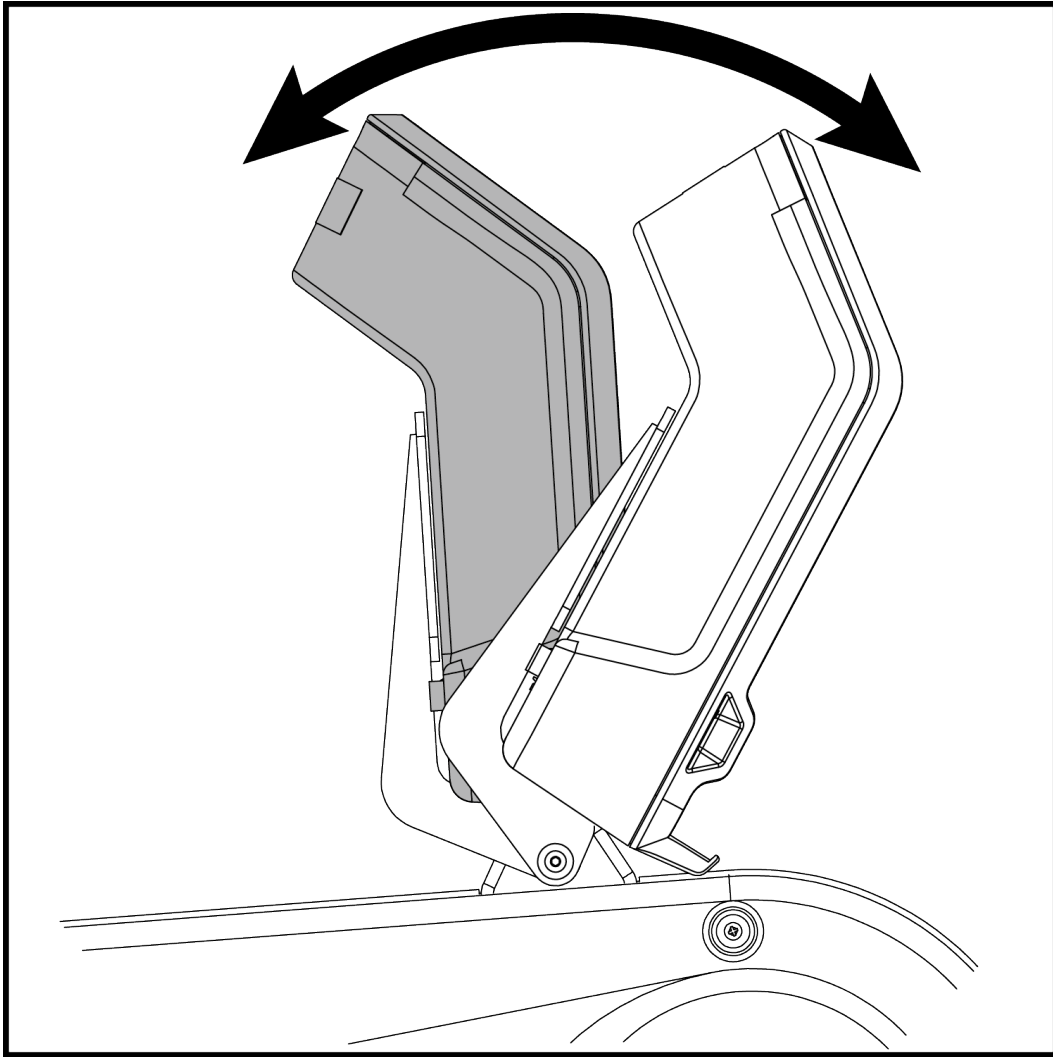

Upper Crank Adjustment

⚠ WARNING: Ensure that the adjustment knob is fully engaged into the hole of the crank rod when adjusting.

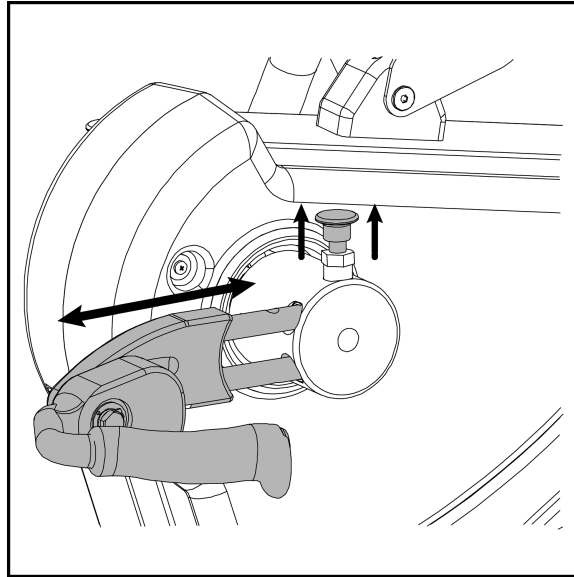

8" (20cm) Radius, 1st hole position

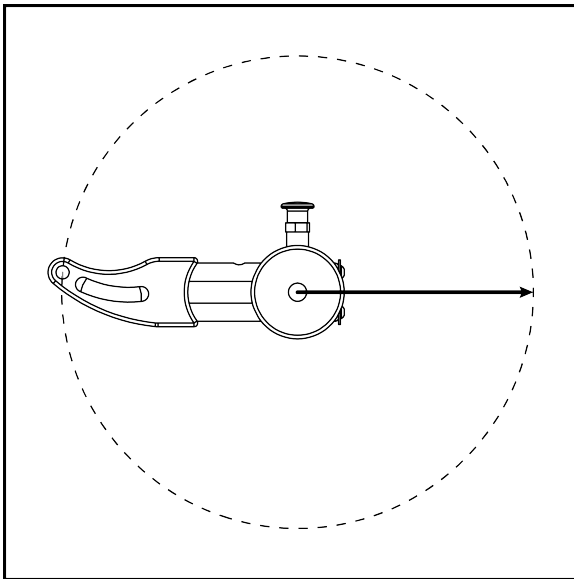

7" (18 cm) Radius, 2nd hole position

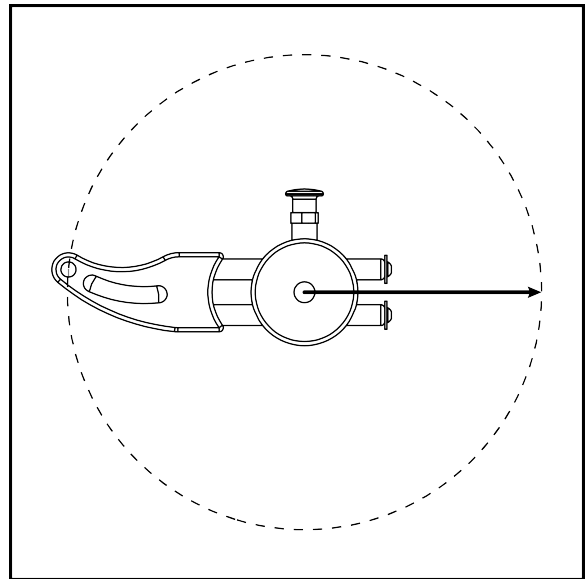

6" (15 cm) Radius, 3rd hole position

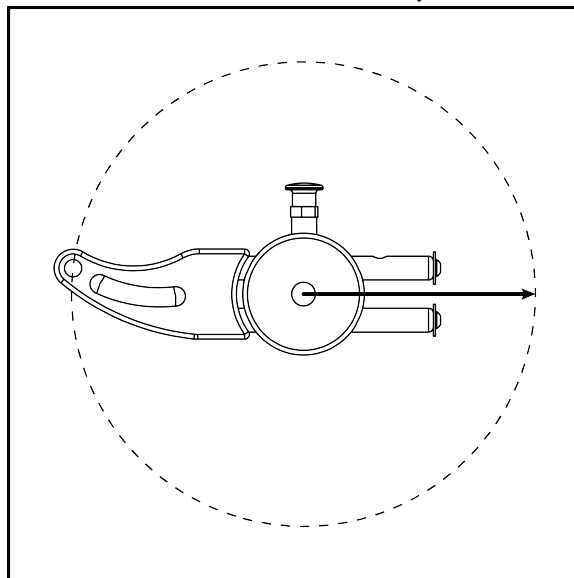

Lower Crank Adjustment

⚠ WARNING: Ensure that the adjustment knob is fully engaged into the hole of the crank rod when adjusting.

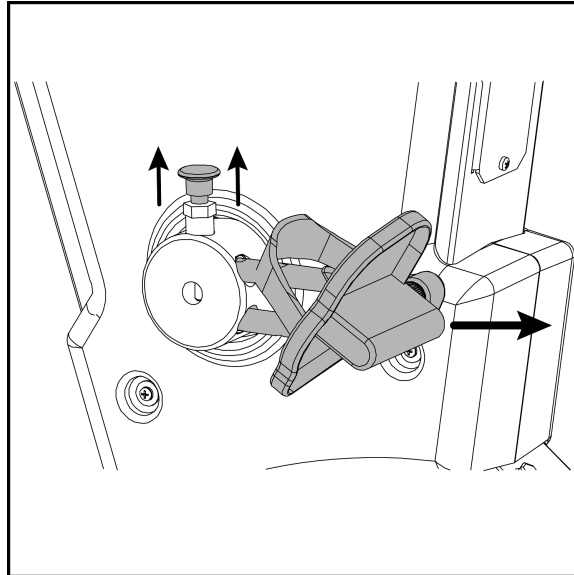

6.85" (17 cm) Radius, 1st hole position

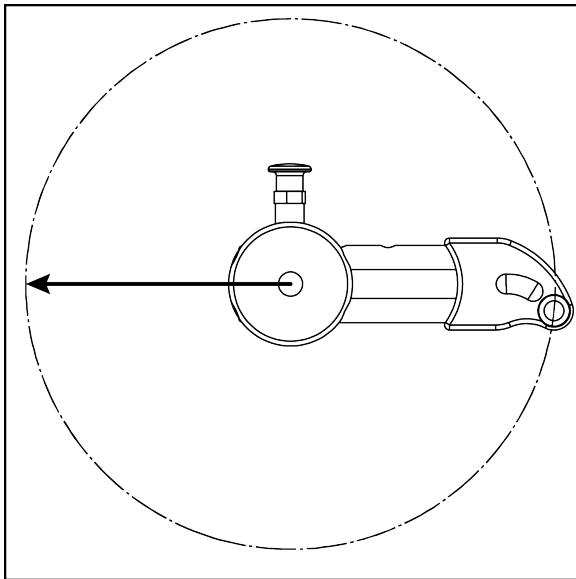

5.60" (14 cm) Radius, 2nd hole position

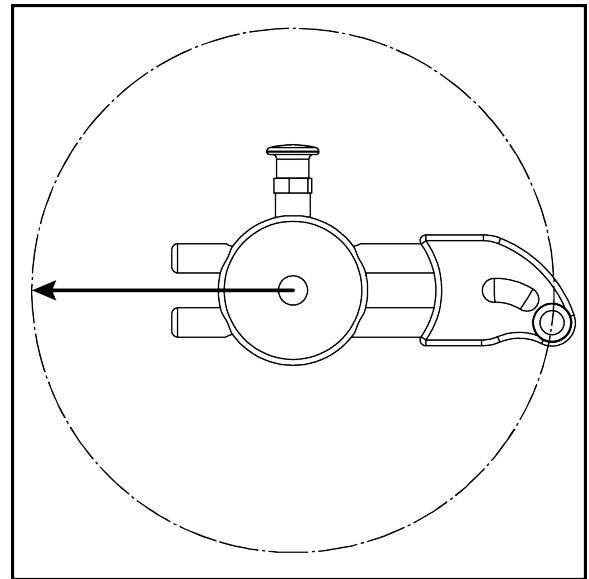

4.35" (11 cm) Radius, 3rd hole position

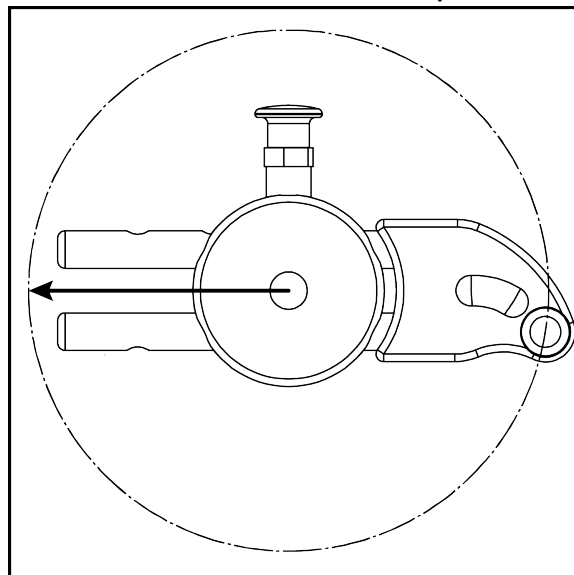

6. Biomechanical Positioning

Machine Entry

1. Choose one of the following to position seat for entry.
 - Press and hold the yellow foot lever located on either side of the seat base (see Seat System manual), then move the seat back to allow sufficient entry space and release the foot lever. You may grab the handles on either side of the console to stabilize yourself and sit on the seat.
 - Lift upward on the yellow swivel lever (Premium only) located on either side of the seat (see Seat System manual) and rotate the seat 90 degrees to the right or left to access the bottom seat pad and release, then sit down and again lift upward on the swivel lever and rotate back into the original position.
2. Position the seat forward or backward to a comfortable location using the yellow foot lever, then release the lever allowing for a slight knee bend when placing your feet on the foot pads or pedals.
3. Adjust the height (Premium only) of the seat using the yellow bar on the front of the seat (see Seat System manual) to obtain a comfortable position.

Initiating a Workout

1. Place your feet on the foot pads or pedals (depends on machine), then grab the handlebars and begin pushing the foot pads or pedals and handlebars continuously to keep the console powered up.

NOTE: The AC adapter may also be connected to the machine to keep the console continuously powered-up.

2. Select the workout program preferred (see Console Program manual) and begin the workout.

Exit the Machine

Choose one of the following ways to exit the machine.

1. Press and hold the yellow foot lever located on either side of the base of the seat base, then move the seat back to allow sufficient exit space and release the foot lever. Carefully lift yourself up and exit the machine.
2. Lift upward on the yellow swivel lever (Premium only) located on either side of the seat and rotate the seat 90 degrees right or left, then release. Carefully lift yourself upward and exit the machine.



7. Specifications

Specifications

PRO2

Max User Weight	Standard Seat - 500 lbs (227 kg) Bariatric Seat- 600 lbs (272 kg) Premium Seat - 450 lbs (204 kg)
Power	Self generating w/auto recharge battery back-up. Standard 18V AC Adapter
Resistance System	Electromagnetic Self Generating Bi-Directional Resistance
Programs	Quick Start, Manual, Constant Workout, ISO-Strength, Hills, Heart Rate, Fit-Quik, Random, Stress Test, Heart Fit Test, Heart Fit Training, Power Fit Test and Power Fit Training
Accuracy Class	Class A
Machine Weight	223 lbs (101kg)
Length	61 in. (155cm)
Height	62 in. (158cm)
Width	30 in. (77cm)

8. Warranty

What is Covered

This Life Fitness commercial exercise equipment product is warranted to be free of all defects in material and workmanship.

Who is Covered

The original purchaser or any person receiving the product as a gift from the original purchaser. Warranty will be voided on subsequent transfers.

How Long it is Covered

All coverage is provided by specific Product according to the guidelines listed in the Warranty Information.

Who Pays Transportation and Insurance For Service

If the Product or any covered part must be returned to a service facility for repairs, We, Life Fitness, will pay all transportation and insurance charges for the first year. You are responsible for transportation and insurance charge after the first year.

What We Will Do To Correct Covered Defects

We will ship to you any new or rebuilt replacement part or component, or at our option, replace the Product. Such replacement parts are warranted for the remaining portion of the original warranty period.

What is Not Covered

Any failures or damage caused by unauthorized service, misuse, accident, negligence, improper assembly or installation, debris resulting from any construction activities in the Product's environment, rust or corrosion as a result of the Product's location, alterations or modifications without our written authorization or by failure on your part to use, operate and maintain the Product as set out in your Operation Manual ("Manual").

One type RJ45 interchangeable Network ready and Fitness Entertainment port is supplied with the Product. This port complies with the FitLinxx CSAFE specification dated August 4, 2004 stating: 4.75 VDC to 10 VDC; maximum current of 85 mA. Any Product damage caused by a load exceeding this FitLinxx CSAFE specification is not covered by warranty.

All terms of this warranty are void if this product is moved beyond the continental borders of the United States of America (excluding Alaska, Hawaii and Canada) and are then subject to the terms provided by that country's local authorized Life Fitness representative.

What You Must Do

Register your Product online at <http://www.scifit.com/warranty-registration-2/>.

Retain proof of purchase; use, operate and maintain the Product as specified in the Manual; notify Customer Support Services of any defect within 10 days after discovery of the defect; if instructed, return any defective part for replacement or, if necessary, the entire Product for repair.

How to Get Parts and Service

Refer to the Corporate Headquarters section of this manual for your local service contact information. Reference your name, address and the serial number of your Product (consoles and frames may have different serial numbers). They will tell you how to get a replacement part, or, if necessary, arrange for service where your Product is located.

Exclusive Warranty

THIS LIMITED WARRANTY IS IN LIEU OF ALL OTHER WARRANTIES OF ANY KIND EITHER EXPRESSED OR IMPLIED, INCLUDING BUT NOT LIMITED TO THE IMPLIED WARRANTIES OF MERCHANTABILITY AND FITNESS FOR A PARTICULAR PURPOSE, AND ALL OTHER OBLIGATIONS OR LIABILITIES ON OUR PART. We neither assume nor authorize any person to assure for us any other obligation or liability concerning the sale of this Product. Under no circumstances shall we be liable under this warranty, or otherwise, of any damage to any person or property, including any lost profits or lost savings, for any special, indirect, secondary, incidental or consequential damages of any nature arising out of the use of or inability to use this Product. Some states do not allow the exclusion or limitation of implied warranties or of liability for incidental or consequential damages, so the above limitations or exclusions may not apply to you. Warranty coverages and terms may differ outside the United States. Please contact the Life Fitness office

servicing your country (contact information found at the front of this manual) or visit the applicable local Life Fitness website to receive the specific warranty information for your country.

Changes in Warranty Not Authorized

No one is authorized to change, modify or extend the terms of this limited warranty.

Effects of State Laws

This warranty gives you specific legal rights, and you may have other rights which vary from state to state and country by country.

Terms of Warranty Coverage

Please use the link below to access component warranty terms:

<http://lifefitness.com/warranties>



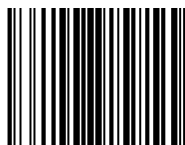

A6780