

ICG CONNECT SYSTEM INSTALLATION GUIDE

MODEL NO: VI-CON-SYS-01

MANUFACTURED BY:

Cytech GmbH
Happurger Str. 86
90482 NUERNBERG | Germany
info@indoorcycling.com
www.indoorcycling.com
Phone: +49(0)911 / 54 44 50



CAUTION!

READ ALL PRECAUTIONS AND INSTRUCTIONS IN THIS MANUAL BEFORE YOU START USING THIS EQUIPMENT. PLEASE KEEP THIS MANUAL FOR FUTURE REFERENCE.
IMPROPER ASSEMBLY, USE OR MAINTENANCE CAN VOID THE WARRANTY TERMS.

ADDITIONAL MANUAL LANGUAGES AVAILABLE FOR DOWNLOAD AT WWW.INDOORCYCLING.COM



CORPORATE HEADQUARTERS

Columbia Centre III, 9525 West Bryn Mawr Avenue, Rosemont, Illinois 60018 • U.S.A.
847.288.3300 • FAX: 847.288.3703 • Service phone number: 800.351.3737 (toll-free within U.S.A., Canada)
Global Website: www.lifefitness.com

AMERICAS

North America

Life Fitness, Inc. Columbia Centre III
9525 West Bryn Mawr Avenue, Rosemont, IL 60018 U.S.A.
Telephone: (847) 288 3300
Service Email: customersupport@lifefitness.com
Sales/Marketing Email: commercialsales@lifefitness.com

Brazil

Life Fitness Brasil
Av. Reboucas, 2315 Pinheiros,
Sao Paulo, SP 05401-300 BRAZIL
SAC: 0800 773 8282 option 2
Telephone: +55 (11) 3095 5200
Service Email: suportebr@lifefitness.com
Sales/Marketing Email: vendasbr@lifefitness.com

Latin America and Caribbean*

Life Fitness, Inc. Columbia Centre III
9525 West Bryn Mawr Avenue Rosemont, IL 60018 U.S.A.
Telephone: (847) 288 3300
Service Email: customersupport@lifefitness.com
Sales/Marketing Email: commercialsales@lifefitness.com

EUROPE, MIDDLE EAST, and AFRICA (EMEA)

Netherlands and Luxemburg
Life Fitness Atlantic BV
Bijdorplein 25-31, 2992 LB Barendrecht
THE NETHERLANDS
Telephone: (+31) 180 646 666
Service Email: service.benelux@lifefitness.com
Sales/Marketing Email: marketing.benelux@lifefitness.com

United Kingdom

Life Fitness UK LTD
Queen Adelaide, Ely, Cambs, CB7 4UB
Telephone: General Office (+44) 1353.666017
Customer Support (+44) 1353.665507
Service Email: uk.support@lifefitness.com
Sales/Marketing Email: life@lifefitness.com

Germany, Austria, and Switzerland

Life Fitness Europe GMBH
Neuhofweg 9, 85716 Unterschleisheim
GERMANY
Telephone:
+49 (0) 89 / 31775166 Germany
+43 (0) 1 / 6157198 Austria
+41 (0) 848 / 000901 Switzerland
Service Email: kundendienst@lifefitness.com
Sales/Marketing Email: vertrieb@lifefitness.com

Spain

Life Fitness IBERIA
C/Frederic Mompou 5,1o1a
08960 Sant Just Desvern Barcelona
SPAIN
Telephone: (+34) 93.672.4660
Service Email: servicio.tecnico@lifefitness.com
Sales/Marketing Email: info.iberia@lifefitness.com

Belgium

Life Fitness Benelux NV
Parc Industriel de Petit-Rechain, 4800 Verviers
BELGIUM
Telephone: (+32) 87 300 942
Service Email: service.benelux@lifefitness.com
Sales/Marketing Email: marketing.benelux@lifefitness.com

All Other EMEA Countries and Distributor Business EMEA*

Bijdorplein 25-31, 2992 LB Barendrecht
THE NETHERLANDS
Telephone: (+31) 180 646 644
Service Email: EMEAServiceSupport@lifefitness.com

ASIA PACIFIC (AP)

Japan
Life Fitness Japan, Ltd
4-17-33 Minami Aoyama 1F/B1F, Minato-ku - Tokyo 107-0062
Japan
Telephone: (+81) 0120.114.482
Fax: (+81) 03-5770-5059
Service Email: service.lfj@lifefitness.com
Sales/Marketing Email: sales@lifefitnessjapan.com

Hong Kong

Life Fitness Asia Pacific LTD
32/F, Global Trade Square
21 Wong Chuk Hang Road
Hong Kong
Telephone: (+852) 2575.6262
Service Email: Service.HK@lifefitness.com
Sales/Marketing Email: hongkong.sales@lifefitness.com

All Other Asia Pacific countries and distributor business Asia Pacific*

32/F, Global Trade Square
21 Wong Chuk Hang Road
Hong Kong
Telephone: (+852) 2575.6262
Fax: (+852) 2575.6894
Service Email: Service.AP@lifefitness.com
Sales/Marketing Email: Marketing.HK.Asia@lifefitness.com

*Also check www.lifefitness.com for local representation or distributor/dealer

Table of Contents

1. IMPORTANT PRECAUTIONS	4
2. SYSTEM SPECIFICATIONS	5
3. PACKAGE CONTENTS.....	5
4. INSTALLATION REQUIREMENTS.....	6
4.1. Power Outlets	6
4.2. Wasp installation	6
4.3. Example Indoor cycling area layout.....	7
4.4. Drilling template	8
5. NOT INCLUDED WITH THE ICG CONNECT SYSTEM	8
Indoor Cycles.....	8
External video device:.....	8
External video device cable:	8
Wasp Network cables	8
Network Cable / Connection to Internet for updating	8
6. UNBOXING	9
INSTALLATION.....	9
7. Assembly & Connection	10
8. CONNECTION SCHEMATIC	13
9. TURNING ON THE ICG CONNECT SYSTEM.....	14
10. SETTINGS MENU.....	14
Entering the Settings Menu	14
11. SETTINGS.....	15
TIME AND DATE SETUP	15
LANGUAGE	15
METRIC.....	15
HDMI AUDIO	15
DEMO MODE.....	15
SYSTEM INFORMATION.....	15
12. Software updates.....	15
12.1. Update via USB Flash drive	15
12.2. Update via ethernet cable and internet connection.	22
CLEANING THE ICG CONNECT SYSTEM	26
WARRANTY	26

1. IMPORTANT PRECAUTIONS

1. It is the sole responsibility of the owner/operator and his staff to ensure that all users are informed of all warnings and precautions prior to using the ICG CONNECT SYSTEM.
2. Position the ICG CONNECT SYSTEM next to the Indoor Cycle on a level surface as recommended in the installation guide. Be sure there is enough space around the ICG CONNECT SYSTEM to mount, dismount and operate the equipment safely.
3. ICG CONNECT SYSTEM is intended for indoor use only. Keep the equipment away from moisture and dust. Do not place the training equipment in a garage, covered patio, near water or pools. Operating temperature of the equipment must be between 15°C~ 40°C Celsius (59°~104°F) at max. humidity of 65%.
4. Regularly inspect all parts of the ICG CONNECT SYSTEM. Please replace defective parts immediately and do not use the equipment until repairs are carried out. Only use original parts from the manufacturer.
5. Keep unattended children away from the ICG CONNECT SYSTEM.
6. **WARNING:** The training equipment can be used by children aged from 14 years and above and persons with lack of experience and knowledge if they have been given supervision or instruction concerning use of the appliance in a safe way and understand the hazards involved. Persons with reduced physical, sensory, or mental capabilities are prohibited from using the training equipment. Children shall not play with the training equipment. Cleaning and user maintenance shall not be made by children without supervision.
7. To ensure the level of safety of the ICG CONNECT SYSTEM a regular maintenance is mandatory.

MEDICAL DISCLAIMER!

Not all exercise programs are suitable for everyone. Please consult your physician before beginning this or any other exercise program. ICG CONNECT programs are designed for fit, healthy, able-bodied users. Any action in response to the instructions provided in this program is at user discretion. You should always warm up for a few minutes before beginning any workout, and you should never exercise beyond the level at which you feel comfortable. The usage of a heart rate monitor is highly recommended!

If at any time you feel you are exercising beyond your current fitness abilities, or you feel discomfort, you must stop your workout immediately! The user assumes all risk of injury in the use of this program.

WARNING: To prevent damage, do not move the unit while the Power, HDMI or Ethernet Cables are connected to the System.

WARNING: To prevent risk of electric shock or fire, do not allow this system to become wet.

Do not expose the ICG CONNECT SYSTEM to moist environments, and do not place liquid filled containers on or near the unit.

ATTENTION: To prevent a risk of electric shock, be sure the power plug is fully and correctly inserted into the wall socket.

CAUTION: RISK OF ELECTRIC SHOCK. DO NOT OPEN!

High voltage is present within the enclosure. Do not open the housing.

Only trained and qualified ICG / Life Fitness service technicians may service the ICG CONNECT SYSTEM.

2. SYSTEM SPECIFICATIONS

ASSEMBLED DIMENSIONS:	53.5 x 36 x 116CM / 22 x 14 x 46IN
ASSEMBLED WEIGHT:	23KG / 51LBS
OPERATING SYSTEM (OS):	ICG Customized Linux OS
COMPUTER:	AMD Ryzen R1505 APU
ASPECT RATIO:	16:9 (External Screen)
SCREEN VIEWING POSITION:	Adjustable - Tilt & Pivot (rotation)
VIDEO RESOLUTION:	Full HD 1080P
SOFTWARE UPDATE:	Internet via Ethernet cable / USB Flashdrive
USB :	1 x 2.0
HDMI :	1 x 1.3
AUDIO PORT :	1 x 3.5MM input
ETHERNET PORT:	RJ45
DISPL AY TYPE:	39CM / 15.6IN IPS Panel with capacitive touch
POWER REQUIREMENTS:	110-220v AC input
LEVELLING FEET:	2
TRANSPORT WHEELS:	2
WARRANTY (PARTS)	1 Year mechanical and electronic components

3. PACKAGE CONTENTS

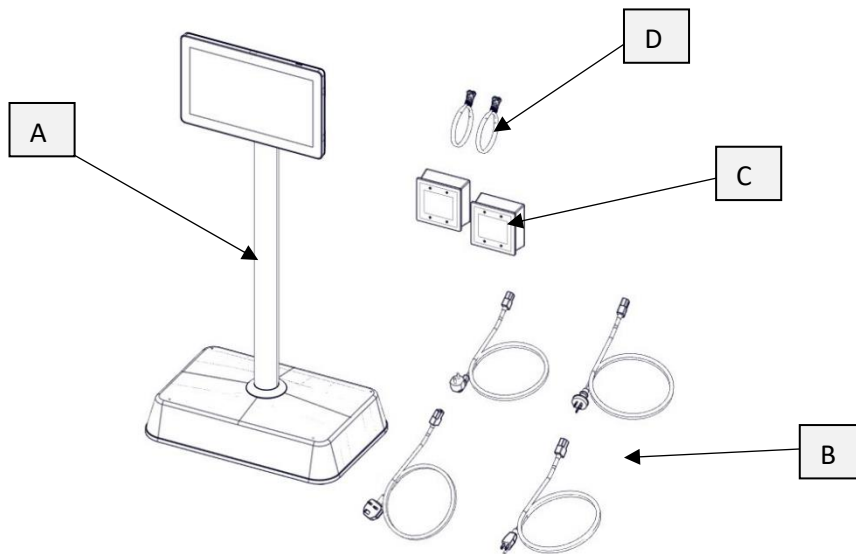

REF.	QTY	Description
A	1	Pre- assembled ICG CONNECT SYSTEM
B	4	ICG CONNECT SYSTEM POWER CABLES EUROPE: CEE 7/7 TYPE F US: NEMA-5 TYPE B UK: BS 1363 AU: AS 3112 TYPE I
C	2	WASP (RECEIVER FOR ANT DATA FROM IC5, 6, 7 & 8 INDOOR CYCLES
D	2	CAT 5 RJ45 NETWORK CABLES FOR TESTING SYSTEM FUNCTIONALITY 1 METER (3 FEET)

4. INSTALLATION REQUIREMENTS

The following requirements must be met for installation and use of the ICG CONNECT SYSTEM.

4.1. Power Outlets

The ICG CONNECT SYSTEM requires one power outlet with 110/220V AC output

4.2. Wasp installation

The ICG CONNECT SYSTEM requires installation of the Cat 5 or better network cables for optimal positioning of the supplied WASPS. The layout of the indoor cycling area may vary from facility to facility and therefore the sourcing of the network cables and installation is the responsibility of the customer.

Network cable requirements (WASPS)

Cat 5 or better network cables / Max. cable length: 50m (164 feet) not included in scope of delivery.

The Wasps should be positioned for optimal coverage of the indoor cycling area with no greater distance than approx. 5m in direct line of sight to the furthest bike for best results.

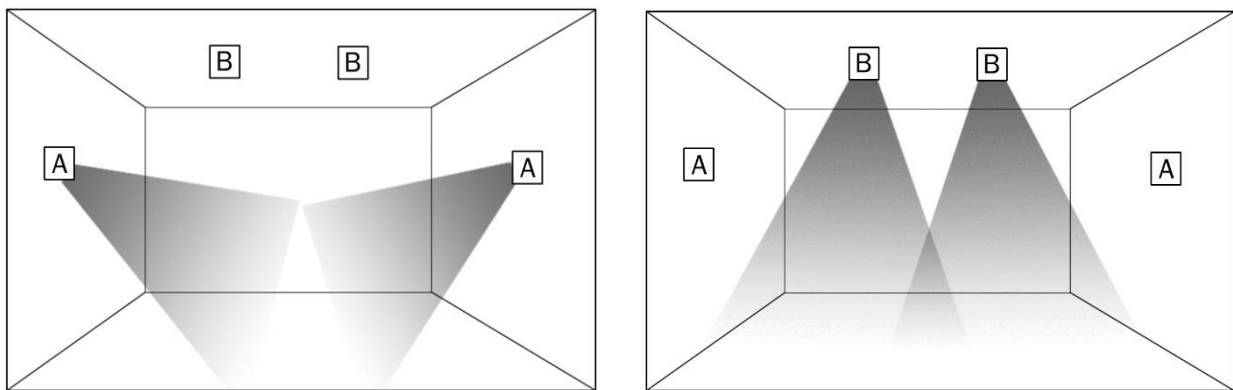

4.3. Example Indoor cycling area layout.

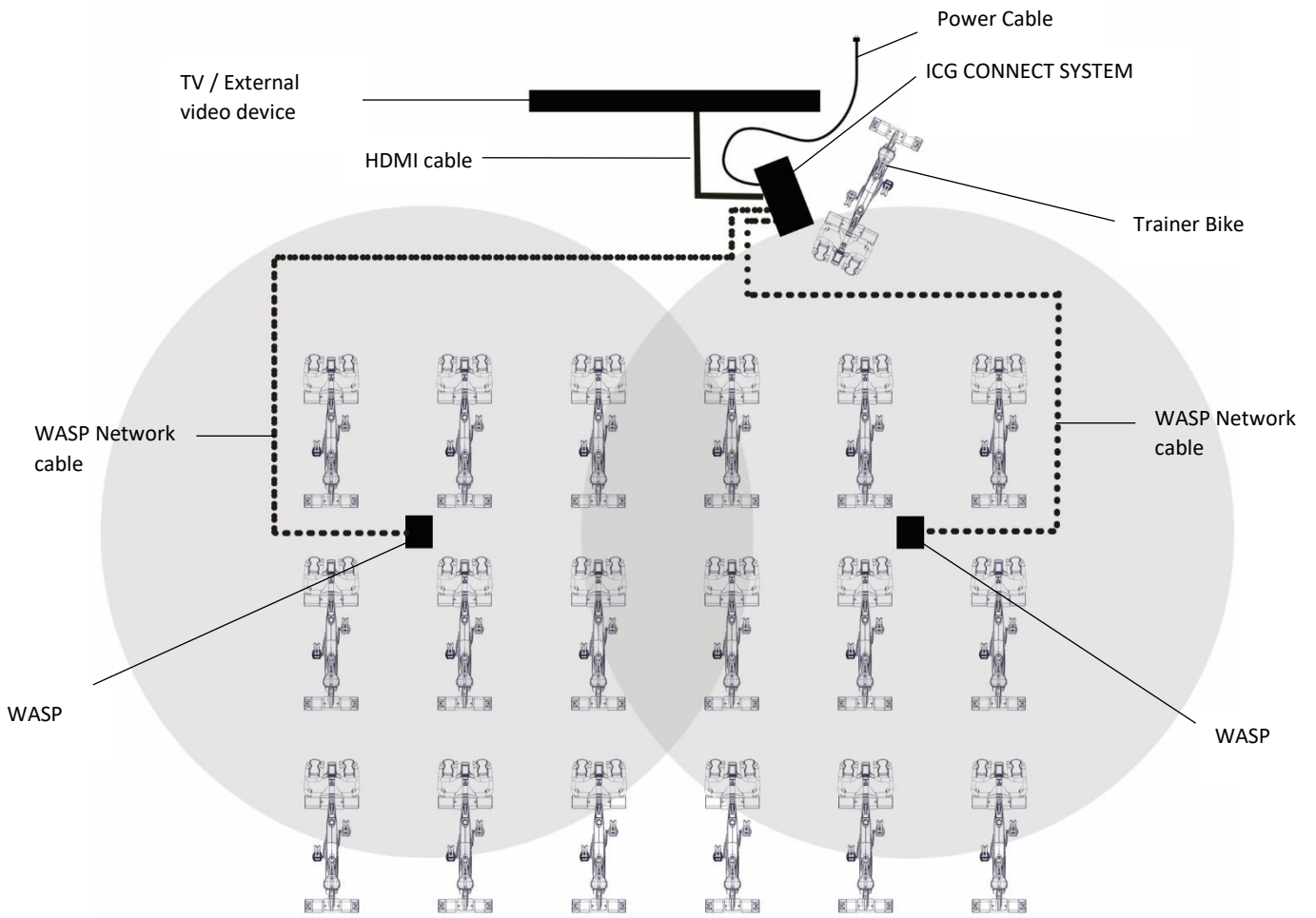

4.4. Drilling template

The Wasps can be mounted according to the Drilling template (hardware not included).

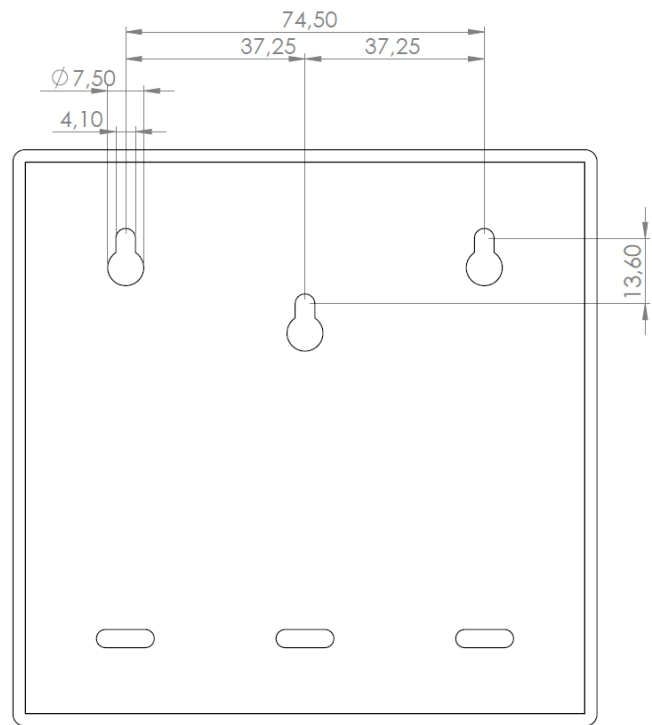

5. NOT INCLUDED WITH THE ICG CONNECT SYSTEM

Indoor Cycles

The ICG CONNECT SYSTEM only works with IC5, IC6, IC7 & IC8 series bikes.

External video device:

TV or Projector
Resolution: 1080P
Input: HDMI 1.3

External video device cable:

High Speed HDMI Cable
Max. length 10m (32 feet)

Wasp Network cables

Cat 5 or better network cables / Max. cable length: 50m (164 feet) not included in scope of delivery.

Network Cable / Connection to Internet for updating

The ICG CONNECT SYSTEM does not require an internet connection for operation. A connection is optional for software updates. Software updates can also be installed by downloading the required file to a USB Flashdrive.

6. UNBOXING

1. Position the box on side and open it as shown below. Lift the ICG CONNECT SYSTEM from the box. Take note to remove any hardware taped to the Styrofoam inside the packaging.

Open the box from the side and remove the Styrofoam and the unit from the box. Be careful not to damage the contents when opening.

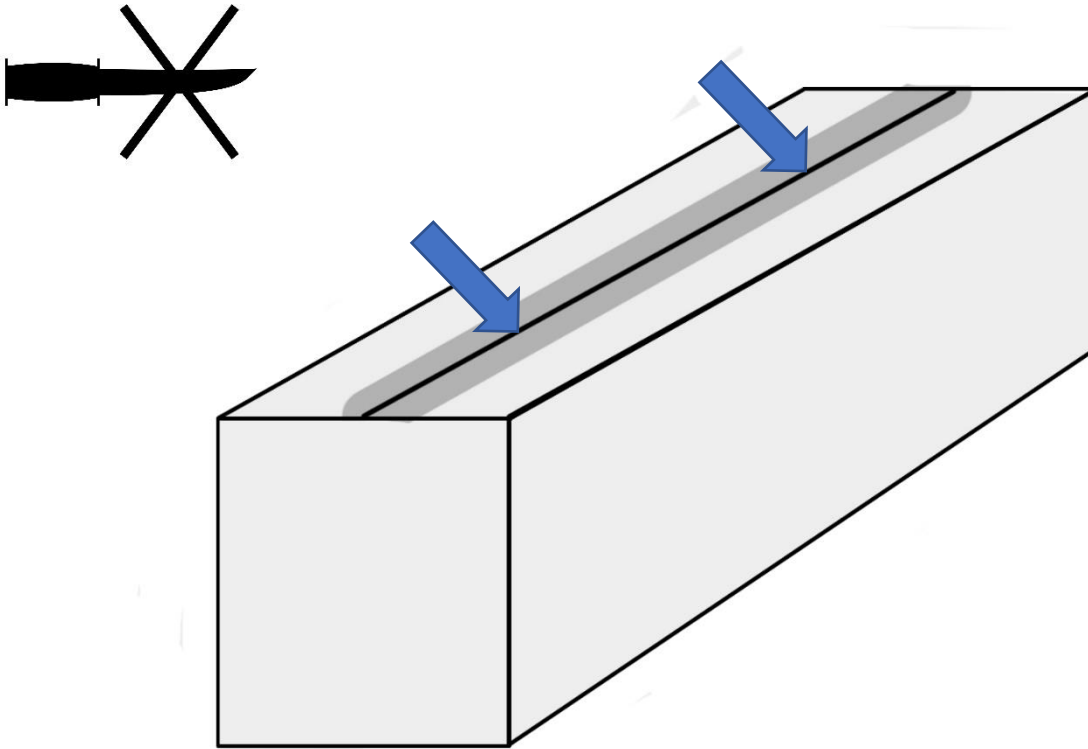

Unboxing Video: / <https://youtu.be/1PzuLkx7Nmo>

7. Assembly & Connection

1. Remove the 3mm Hex screw from the rear of the base.

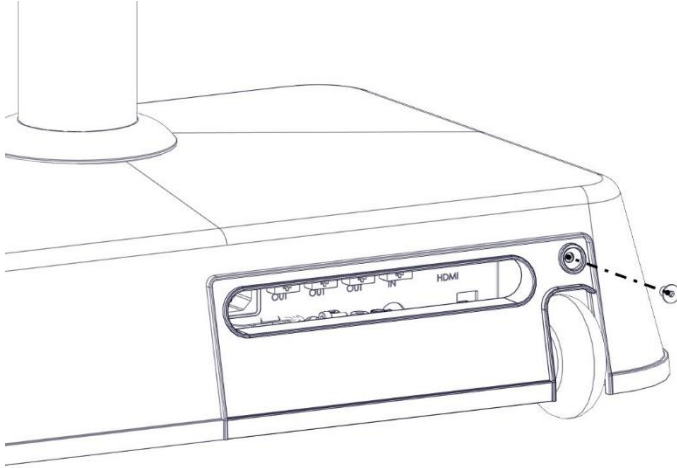

2. The panel is hinged on the left side. Pull the panel from the right side.

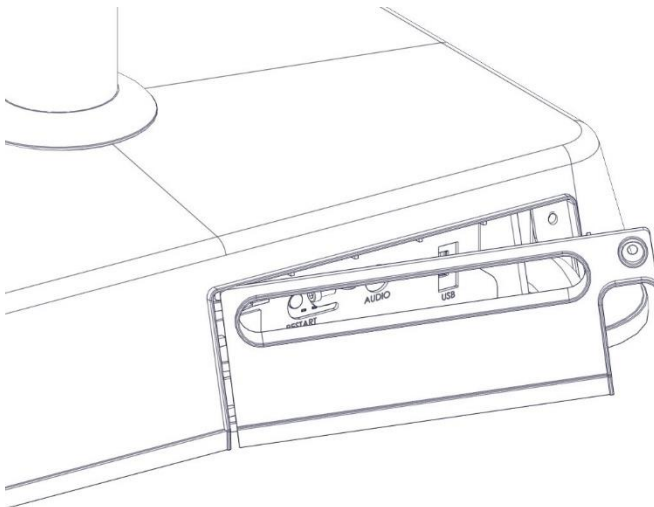

- Slide the power cable for your region, HDMI cable, both network cables for the WASPs and the optional network cable for updates through the slot of the removable cover.

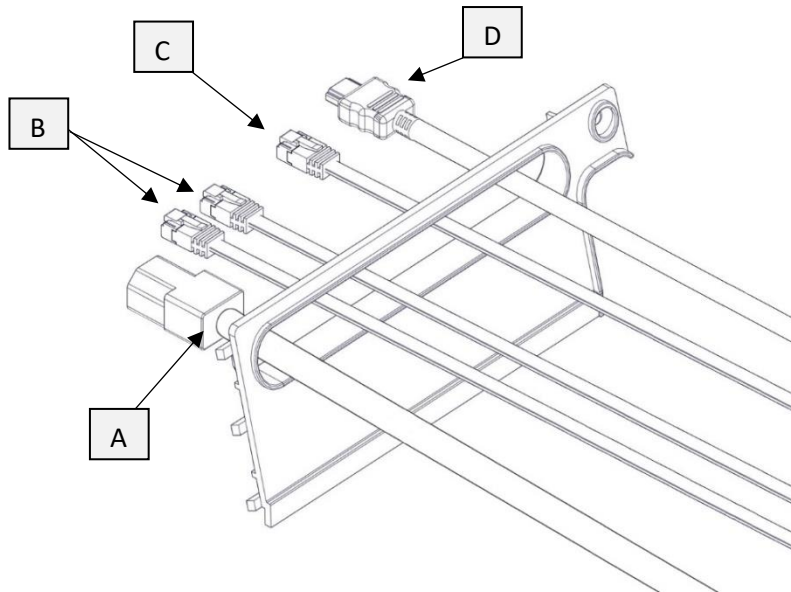

REF.	QTY	Description
A	1	Power Cable
B	2	CAT 5 or better RJ45 cables for the Wasps (max 50m /164 feet)
C	1	CAT 5 or better RJ45 cable for the optional internet connection for updates.
D	1	High Speed HDMI Cable (Max 10m / 32ft)

- Plug in the power cable (A).
- Connect your TV or external video device with the HDMI cable (D) into the connector panel labeled HDMI.
- Plug in the network cables for the WASPs into the RJ45 sockets marked "OUT". The system can support up to 3 WASPs but only 2 are required for most facilities. Additional WASPs sold separately.
- If you would like to connect the system to the internet, connect to your network with internet connection with a network cable to the RJ45 socket marked "IN".

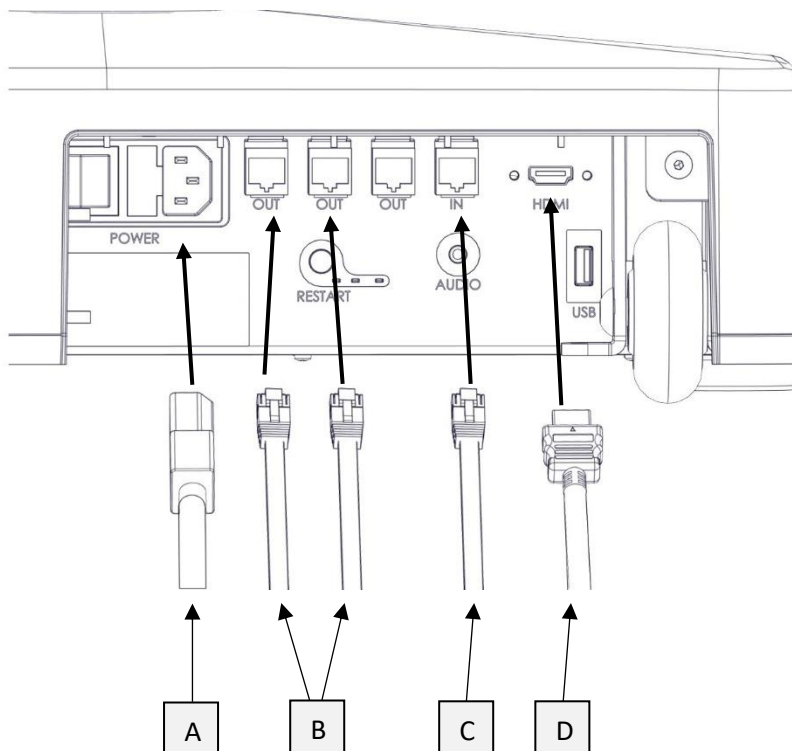

REF.	QTY	Description
A	1	Power Cable
B	2	CAT 5 or better RJ45 cables for the Wasps (max 50m /164 feet)
C	1	CAT 5 or better RJ45 cable for the optional internet connection for updates.
D	1	High Speed HDMI Cable (Max 10m / 32ft)

8. Remove the lid from the WASP (fig. 1) with a small flat head screwdriver and plug in the other end of the network cables from the ICG CONNECT SYSTEM to the WASPs (fig. 2). Cut the plastic of the WASP at the predetermined areas for routing the cable best suited for your installation.

WARNING! Installed WASPs and Cat 5 or better network cables from an older MYRIDE CONNECT can be used for the ICG CONNECT SYSTEM but the old POEs must be removed before use.

fig. 1

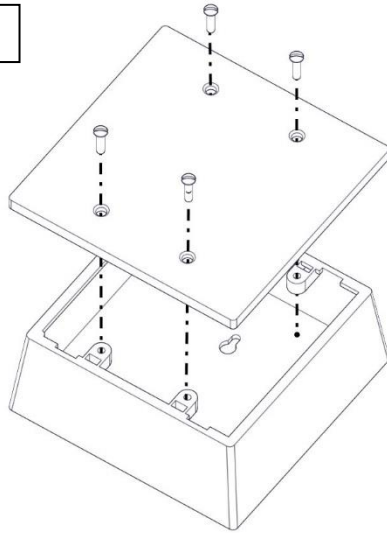
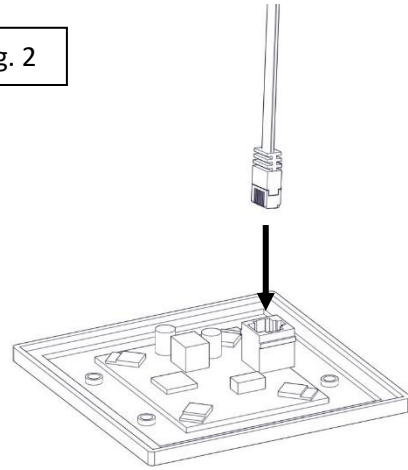
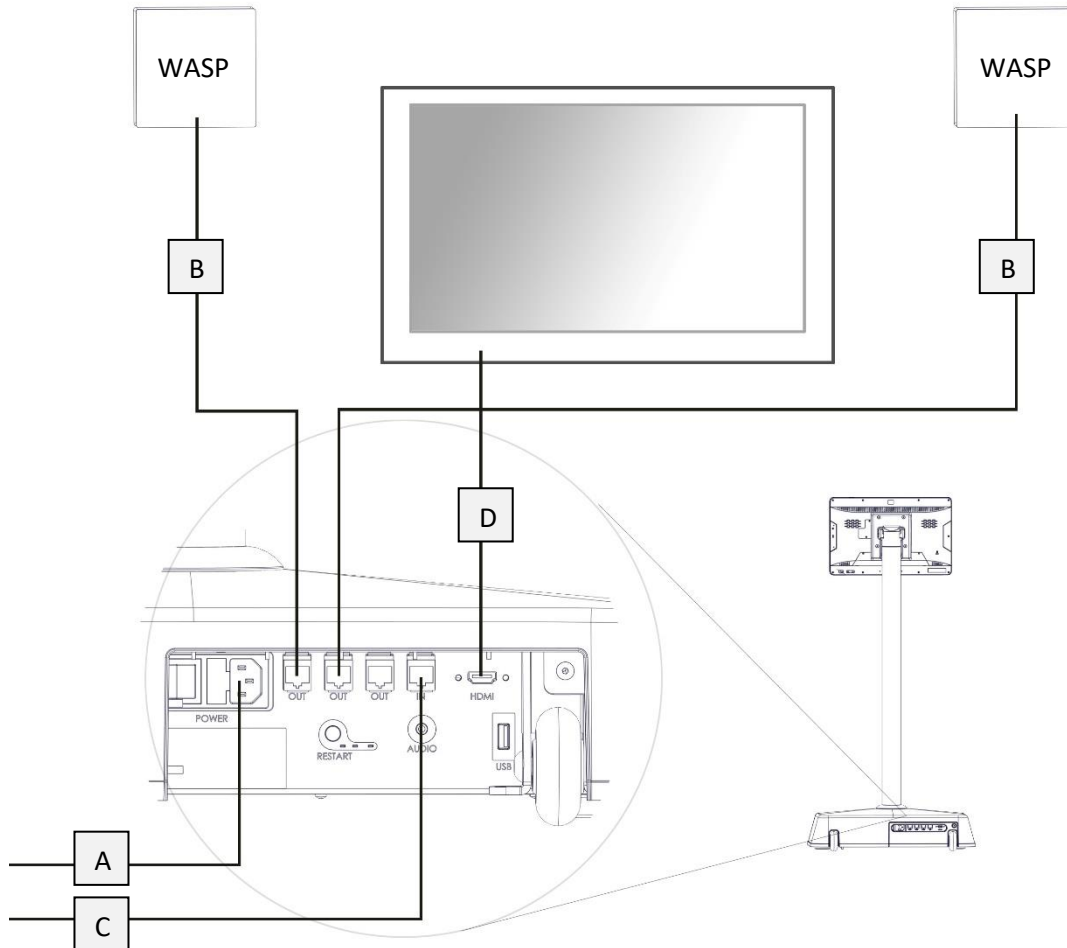

fig. 2



8. CONNECTION SCHEMATIC



REF.	QTY	Description
A	1	Power Cable
B	2	CAT 5 or better RJ45 cables for the Wasps / Max length 50m (164 ft)
C	1	CAT 5 or better RJ45 cable for the optional internet connection
D	1	High Speed HDMI Cable / Max 10m (32ft)

9. TURNING ON THE ICG CONNECT SYSTEM

1. Make sure the system is connected properly (The Connect System must be connected to an external video device with 1080P).
2. Turn on your external video device.
3. Turn on the unit by flipping the power switch on the back of the base of the unit (fig. 1). Pushing the restart button will turn off the Mini Pc but we advise always using the main power switch (fig 1.) to turn off the system.

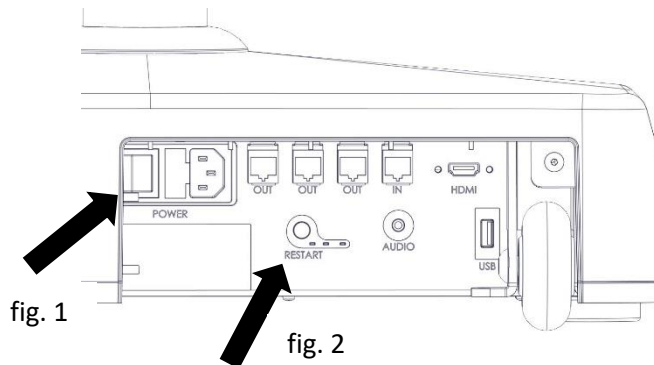

4. The system takes approx. 90 seconds to fully boot. The ICG logo will appear on the external video device and the tablet will show the home screen.

10. SETTINGS MENU

You will need to enter the setup menu to set up the time, activate demo mode and install updates on your ICG CONNECT SYSTEM. Do not make any adjustments to the system not outlined in this manual.

Entering the Settings Menu

1. In the home screen, press the "MENU" button on the lower right-hand corner.

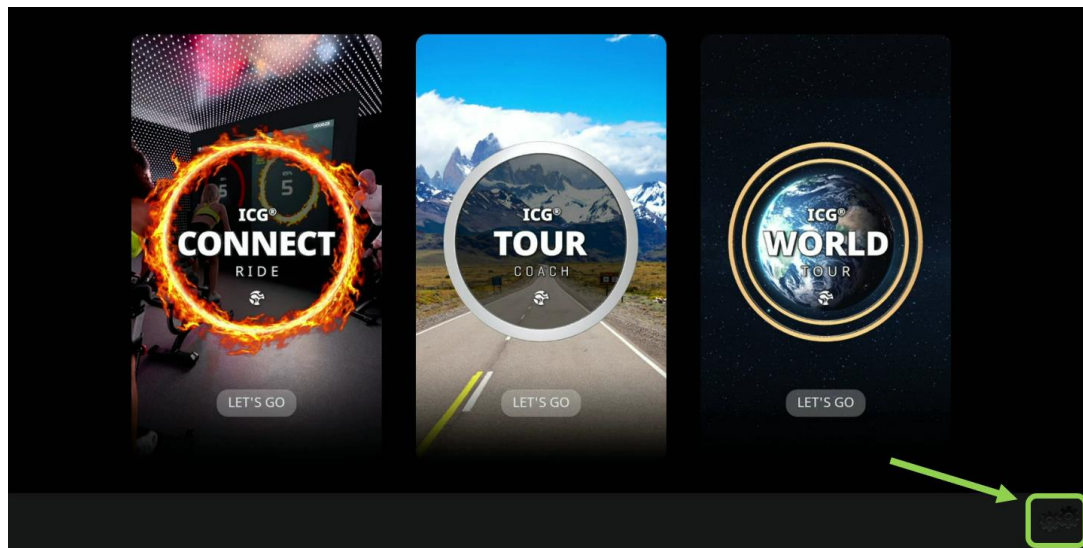

2. Confirm the prompt "FOR STAFF USE ONLY".
3. Enter the password: 4,3,2,1 and confirm

11. SETTINGS

TIME AND DATE SETUP

In the SETTINGS menu touch the Time button and make your local adjustments and leave the menu with the back button.

LANGUAGE

Touch the button to change your language preferences.

METRIC

The ICG CONNECT SYSTEM can be used with either Metric or Imperial units. When the button next to the Metric is green, Metric units are used. When the button is grey, Imperial units are used. To change your preferred unit, touch the button.

HDMI AUDIO

Some videos (ambient sound) or introductions to World Tour Videos have sound but no music. When HDMI Audio is selected, the external video device will play the sound provided the device has speaker. If not activated, sound output will be through the audio jack on the base of the system but is generally not required as the trainer will play their music during the workout.

DEMO MODE

When activated and the button green, the demo mode will simulate user data from 20 bikes and display the information on the tablet and external video device. Live user data from any bikes will not be displayed.

SYSTEM INFORMATION

The system information tab has software version details for the tablet and the internal mini pc. When requesting support, always provide the App Version and Software version.

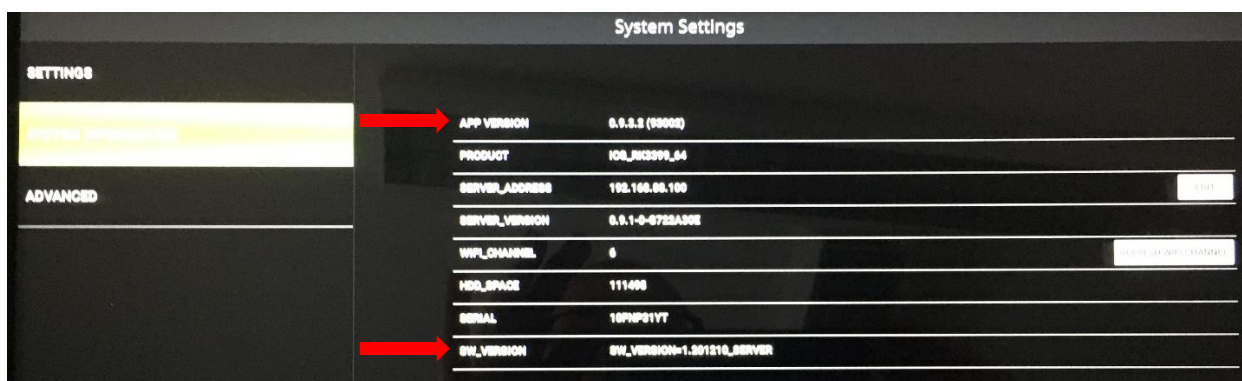

12. Software updates

Always perform a software update after installation to be sure the unit has the latest software version!

The software can be updated by either downloading the software in the provided link and copying it to an USB flash drive or by connecting the unit to an unrestricted internet via ethernet cable. The update is saved on the media server and contains both updates for the media server and the tablet, so only one download is required.

12.1. Update via USB Flash drive

The update process when updating via USB Flash Drive is completed in 2 steps. First the update is installed on the Media Server and then manually started on the tablet.

Video: <https://youtu.be/GP3wx-UvKkl>

Software download:

http://kb.cybexintl.com/Software/ICG_Connect_System/ICG_Connect_System.zip

- 1) Download the software file from the Life Fitness Service and Support homepage
- 2) Unzip and save the file to an empty USB Flash drive with min 1 – 10 GB Capacity
- 3) Make sure the system is connected to an external video device (TV) via HDMI cable and turn the external video device and ICG CONNECT SYSTEM on.
- 4) Once the system is booted and the ICG log is displayed on the TV and the Tablet is booted and displaying the ICG logo (fig. 1), insert the USB Flash drive in the USB port on the rear of the unit fig. 2.

Fig. 1

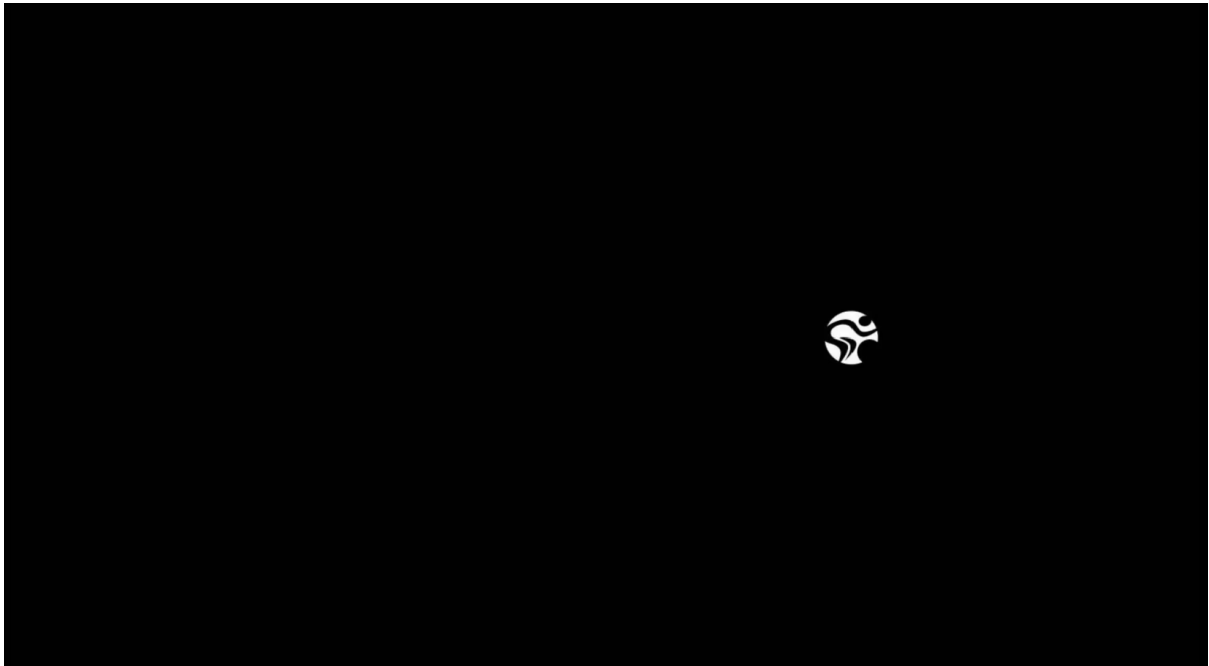
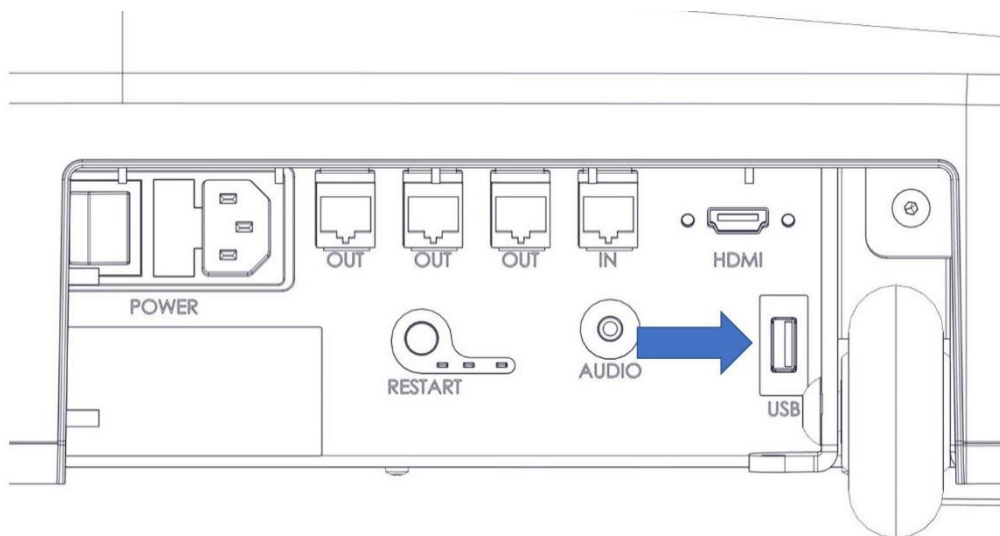

Fig. 2



- 5) The TV will indicate that an update was found on the USB flash drive. Once the countdown is completed, the unit will copy the update for the Kiosk and Tablet to the system.



- 6) Once the update is copied to the system, you will be prompted to remove the USB flash drive and the system will automatically reboot. After reboot the update will be installed, and the system will reboot again. Please note that the tablet will not restart.

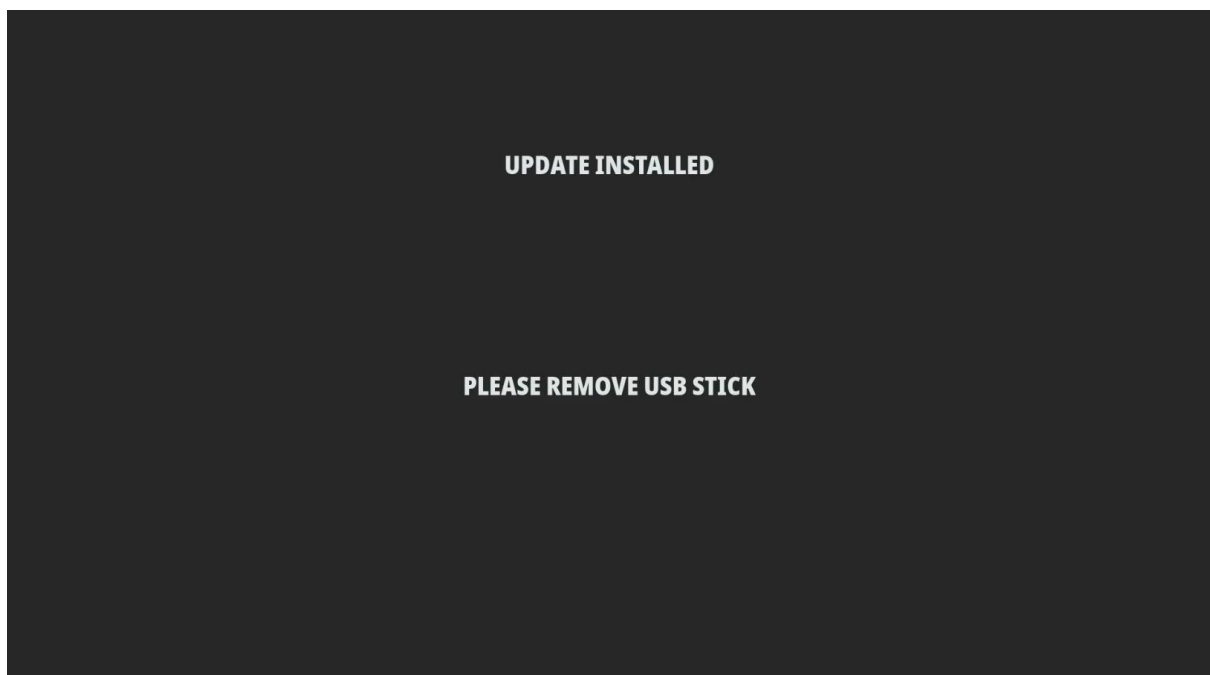

After the update is completed on the media server the ICG logo will appear on the TV.

- 7) To update the media server, tap the gear icon on the lower righthand corner of the home screen on the tablet. Please that the icon is barely visible.

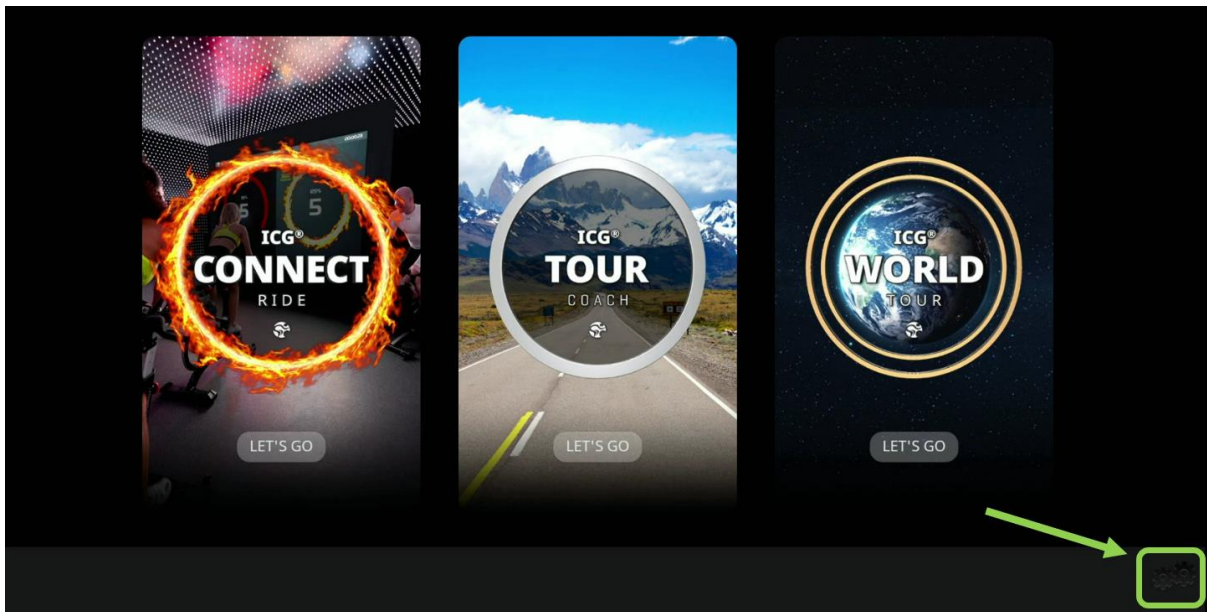

- 8) Enter the code to access the system settings of the tablet. 4, 3, 2, 1. The code is the same for all systems and cannot be changed.

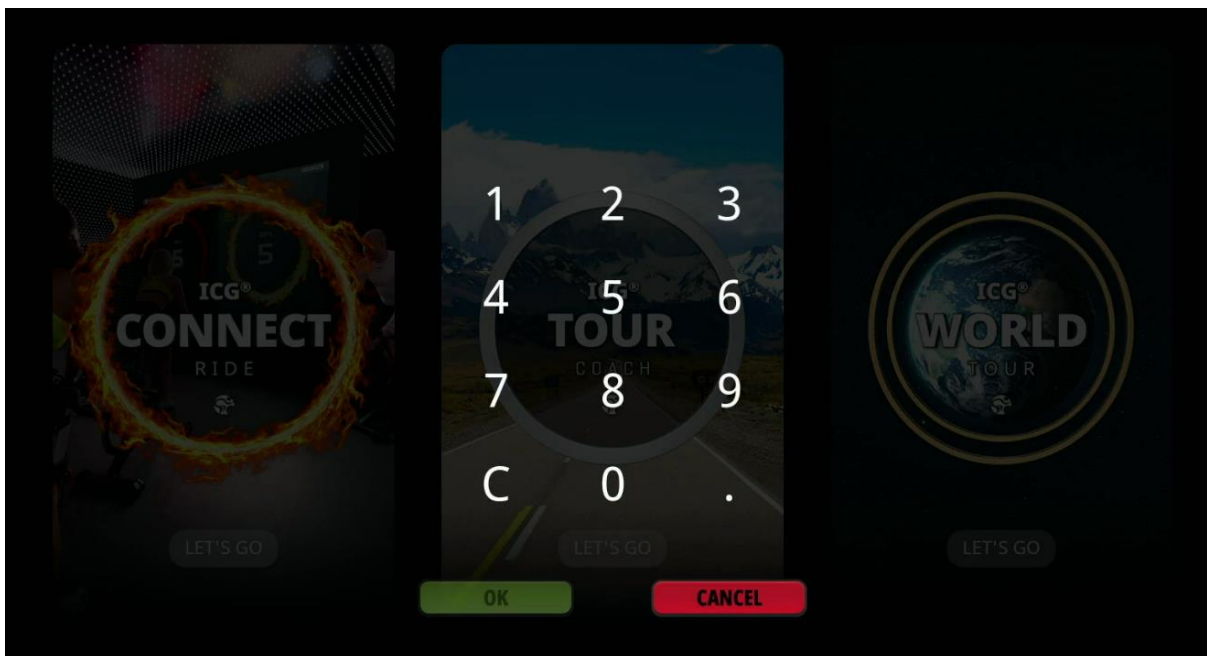

- 9) Tap the update system on the screen (fig. 1) and the system update will begin (fig.2).
Fig. 1

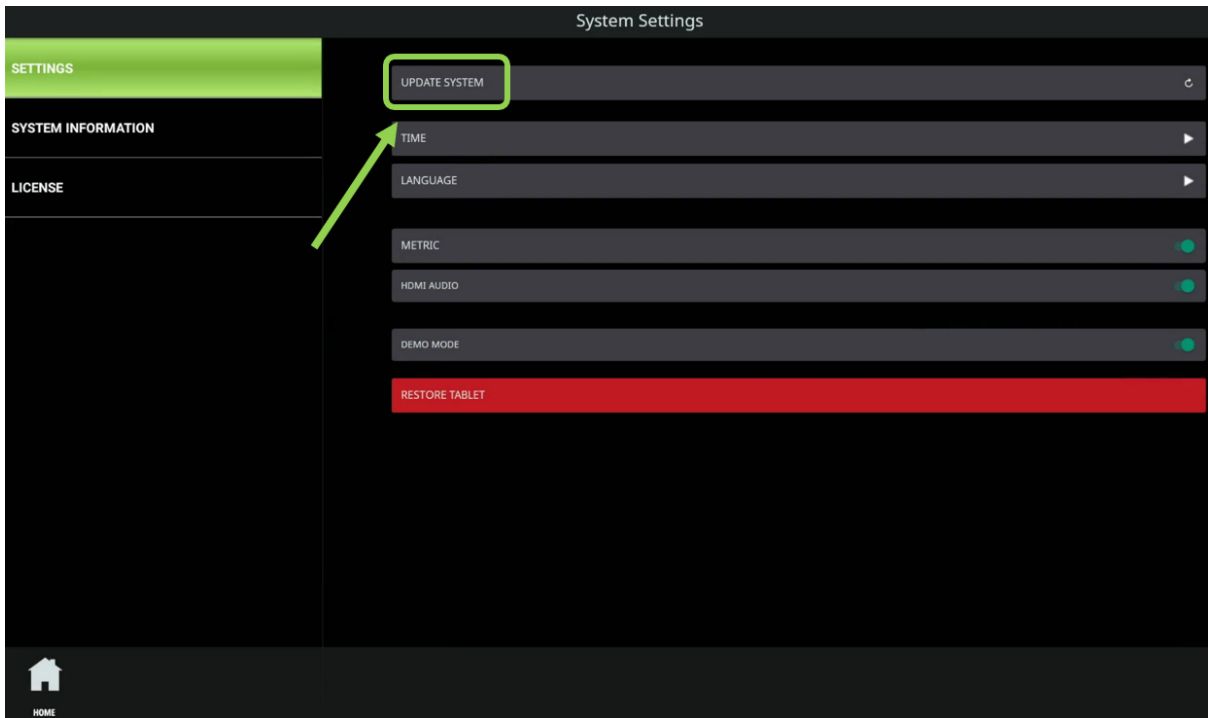
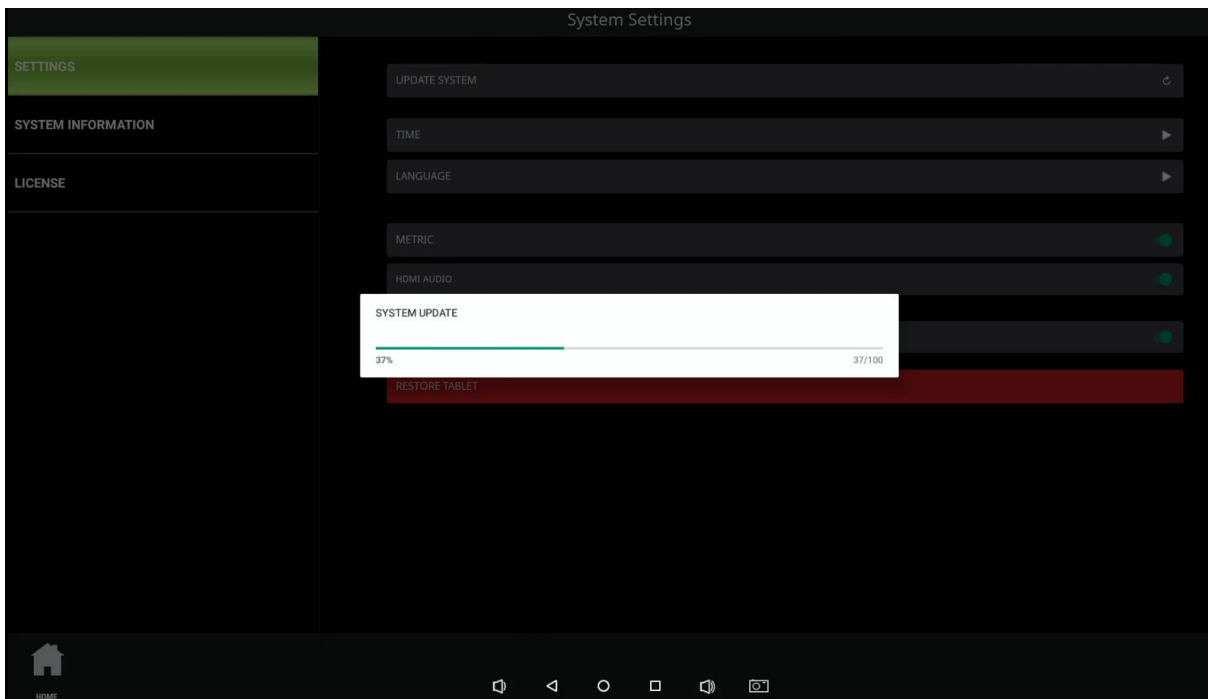
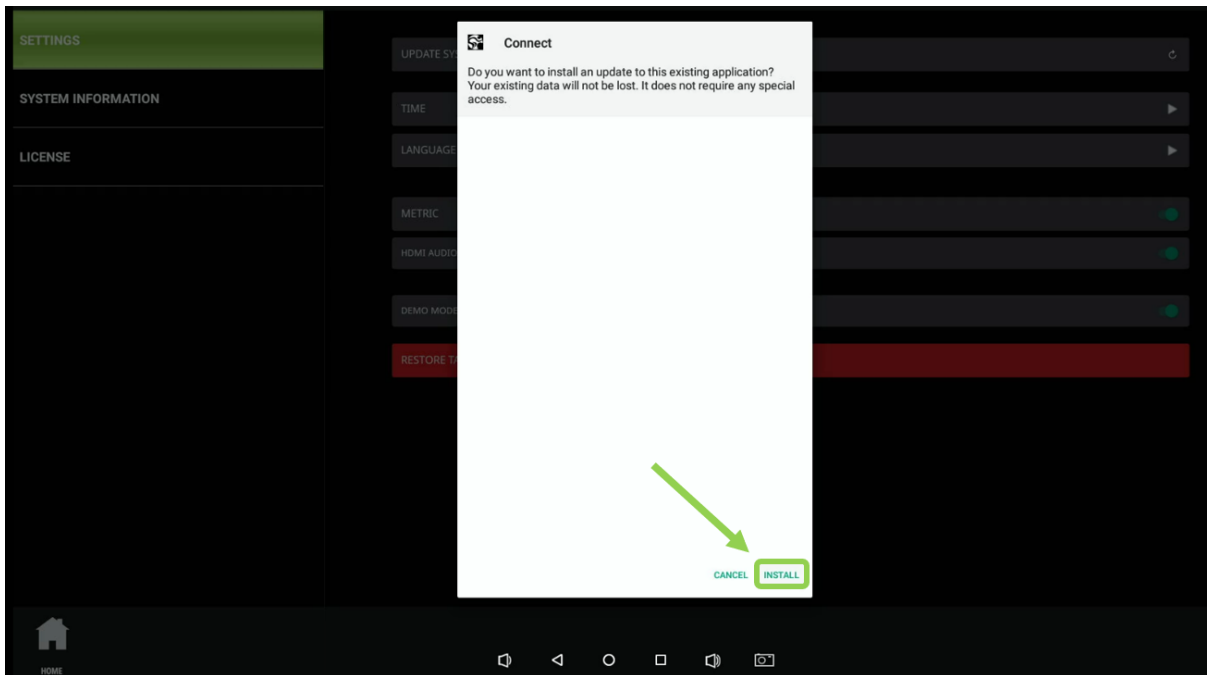

Fig. 2



10) Tap the install button when prompted and the update will start. Once completed, you will automatically be brought back to the home screen.



11) Confirm the update versions by going into the settings menu (steps 7 & 8) and tapping the system information button to display the software versions.

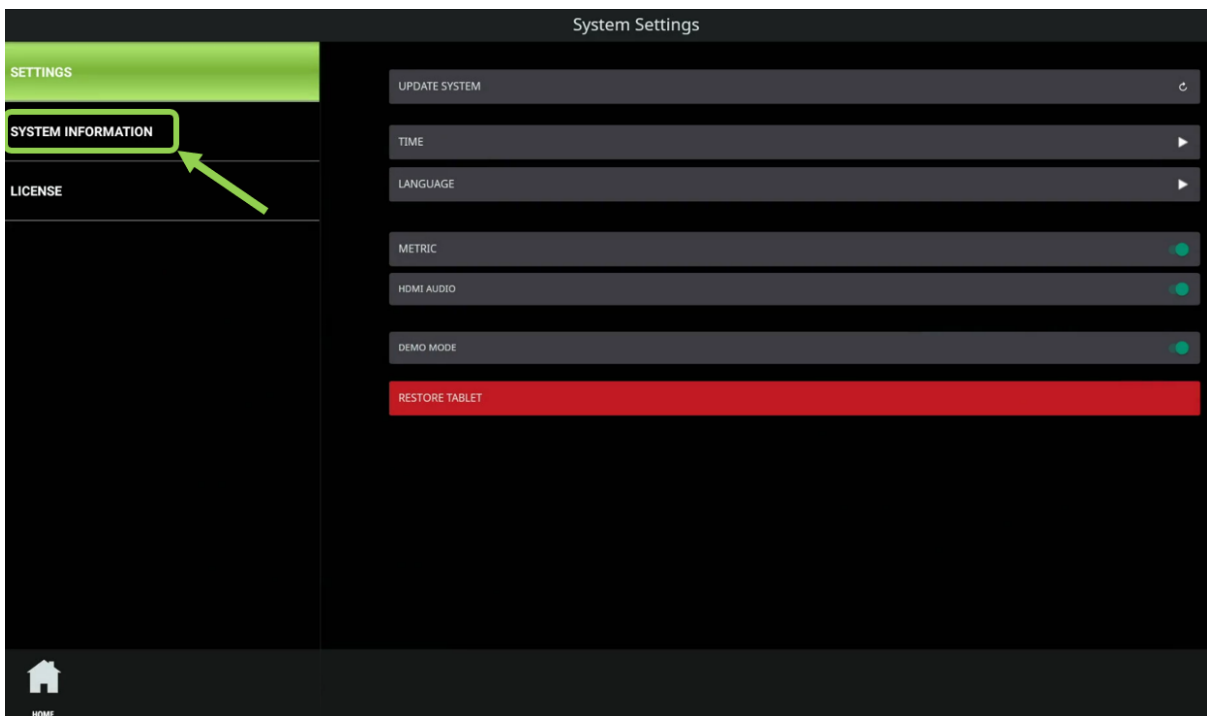

12) Confirm that the update was successful.

APP VERSION (Fig. 1)

SERVER VERSION (Fig. 2)

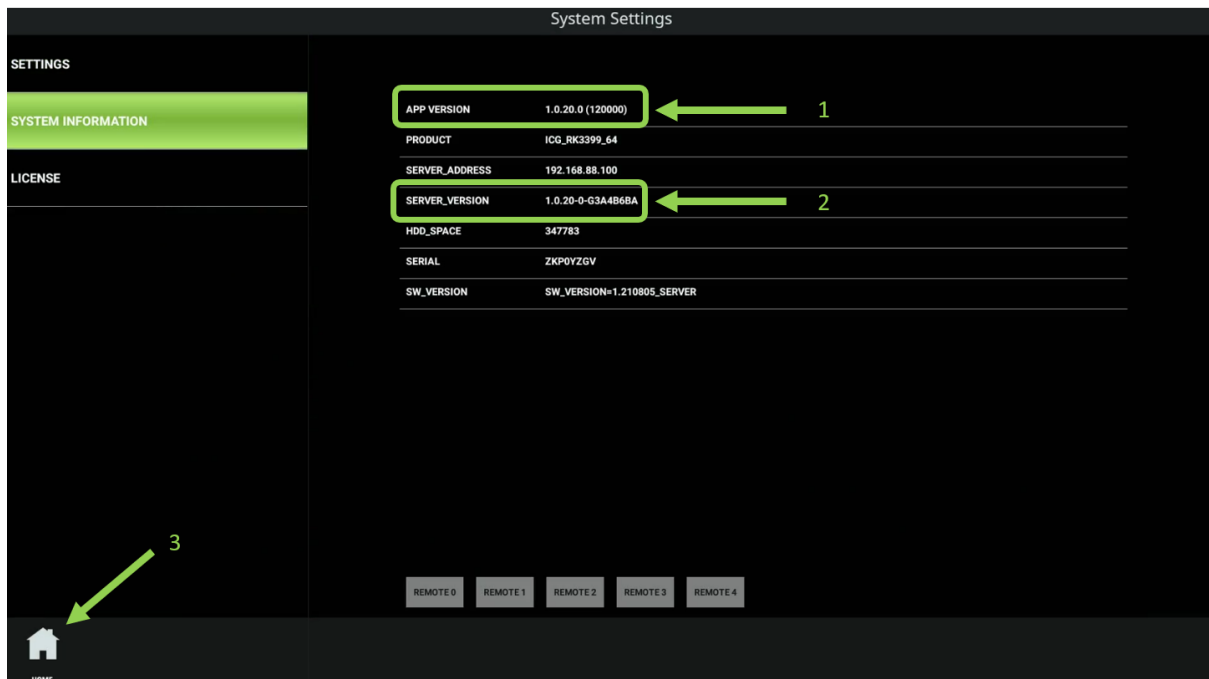

Leave the Settings screen by tapping the home icon (Fig. 3)

13) After the update, manually restart the system using the power switch on the back of the system.

12.2. Update via ethernet cable and internet connection.

The system must be connected to the internet via ethernet cable. The internet connection must be free of restrictions and firewall. If such a connection is not available, please refer to updating via USB flash drive. The system will download the software and install it automatically. You will then be prompted on the tablet to confirm update of the tablet software.

- 1) Connect an ethernet cable to the "IN" port.

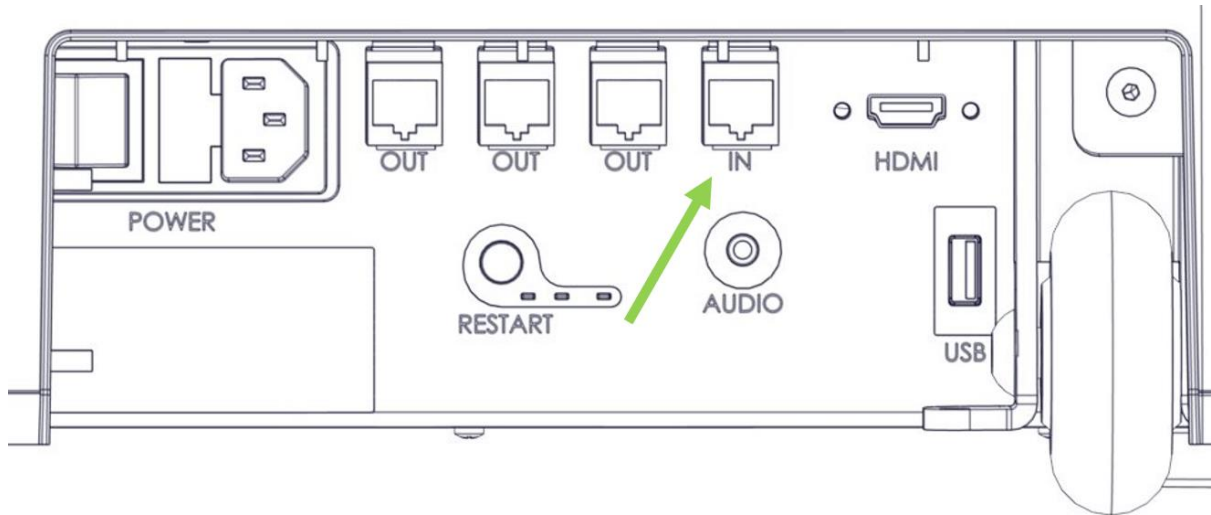

- 2) Tap the gear icon on the lower righthand corner of the home screen on the tablet. Please note that the icon is barely visible.

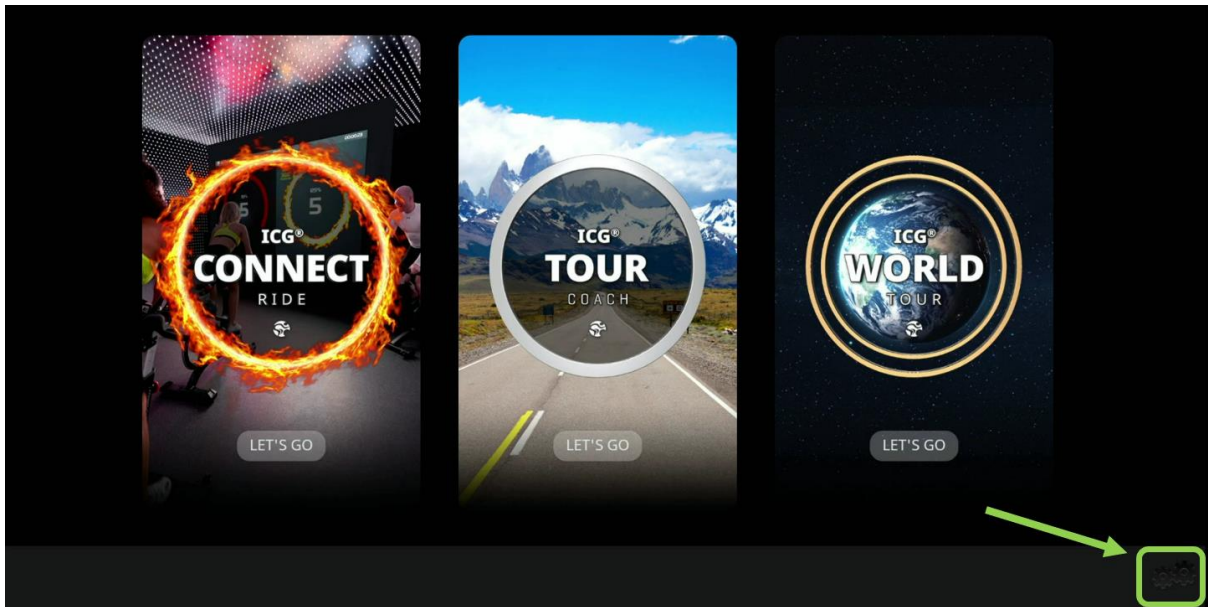

- 3) Enter the code to access the system settings of the tablet. 4, 3, 2, 1. The code is the same for all systems and cannot be changed.

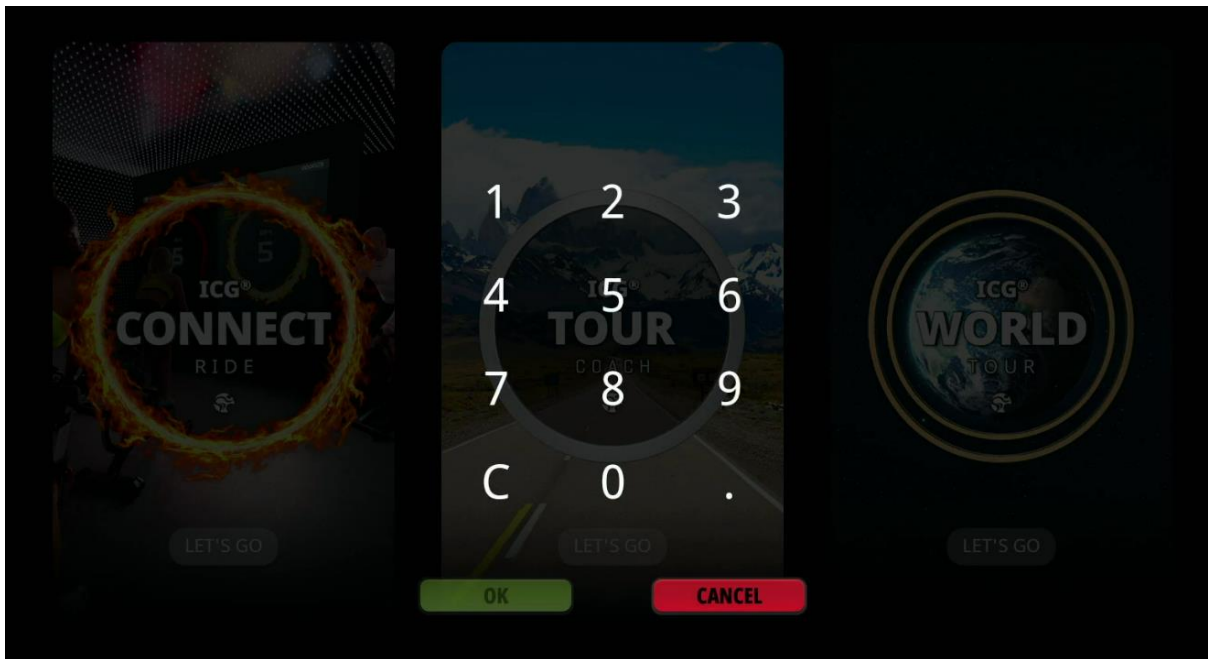

- 4) Tap the update system on the screen (fig. 1) and the system update will begin and restart the media server (fig.2).

Fig. 1

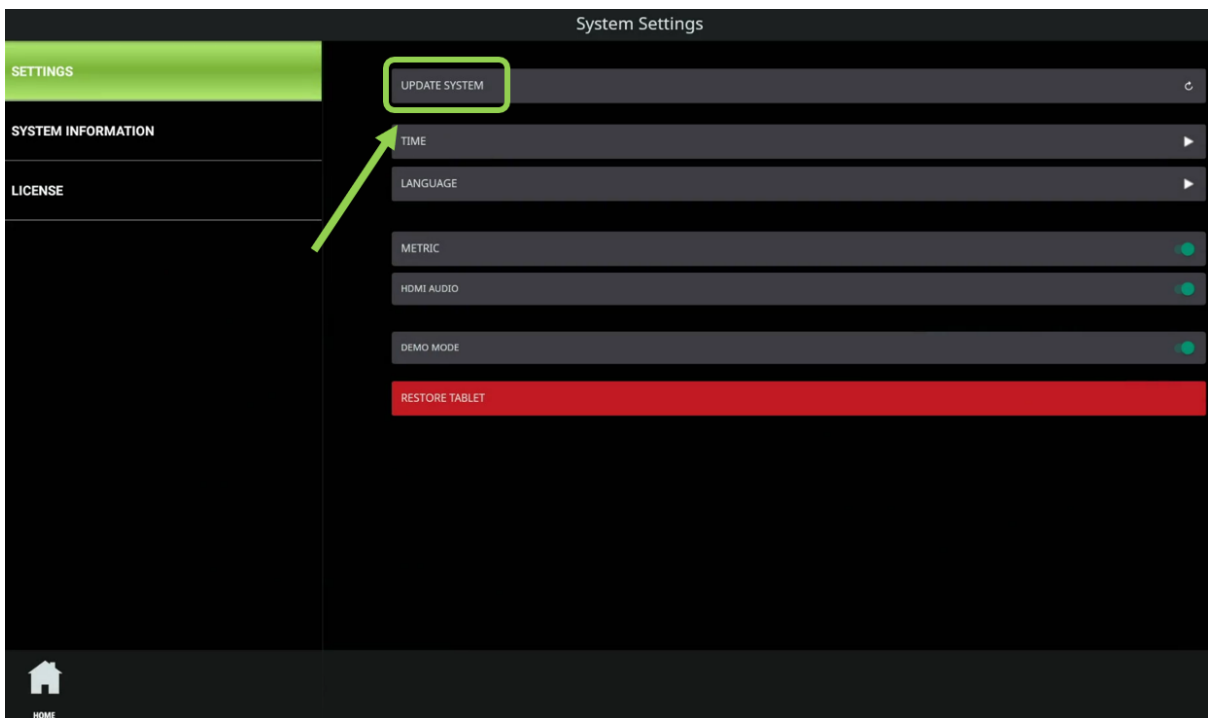
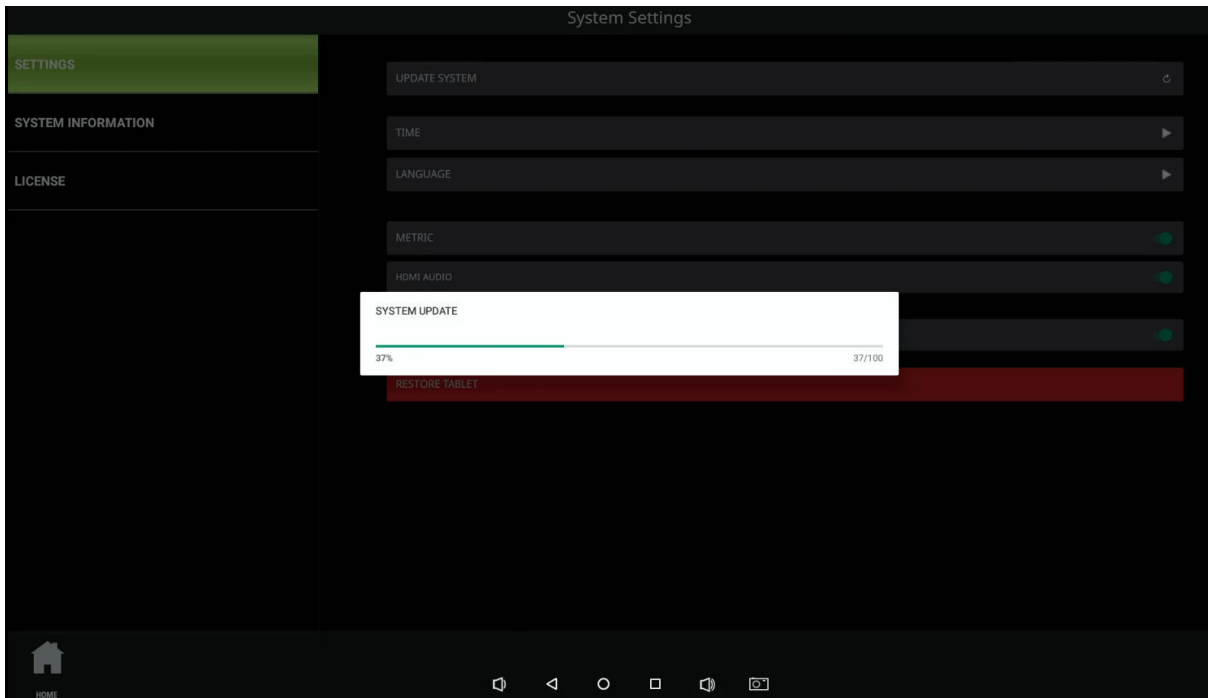
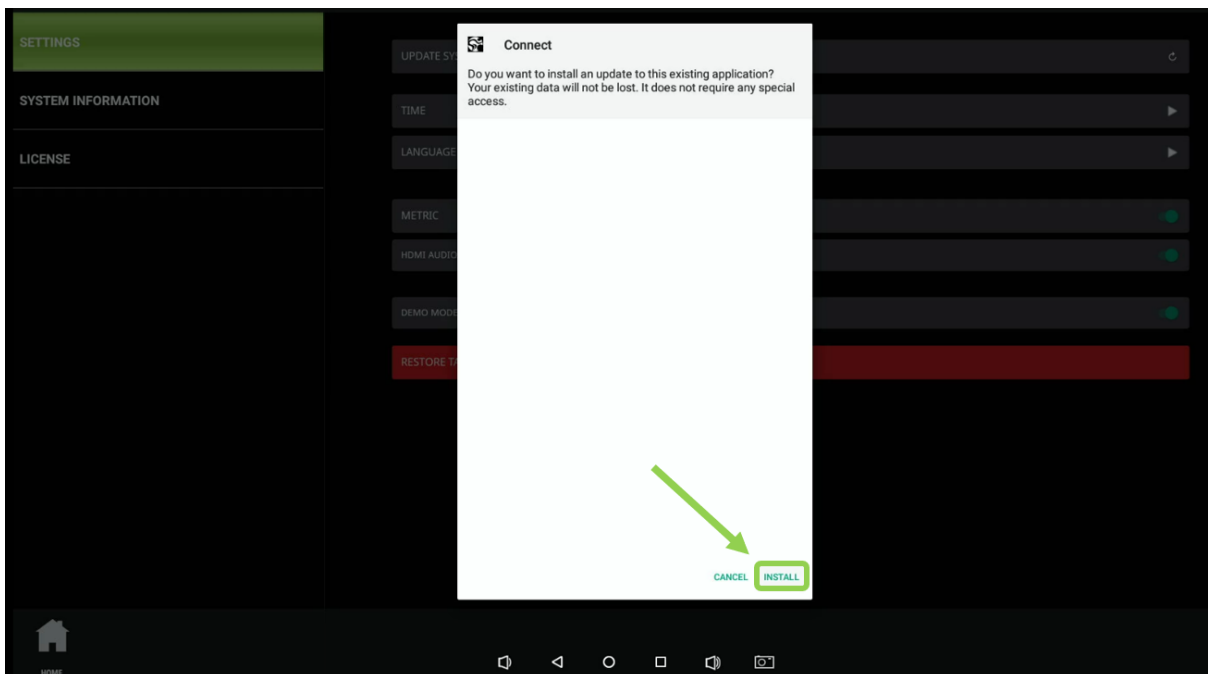

Fig. 2



- 5) After the installation on the media server, you will be prompted to confirm the update on the tablet. Once completed, you will automatically be brought back to the home screen.



- 6) Confirm the update versions by going into the settings menu (steps 7 & 8) and tapping the system information button to display the software versions.

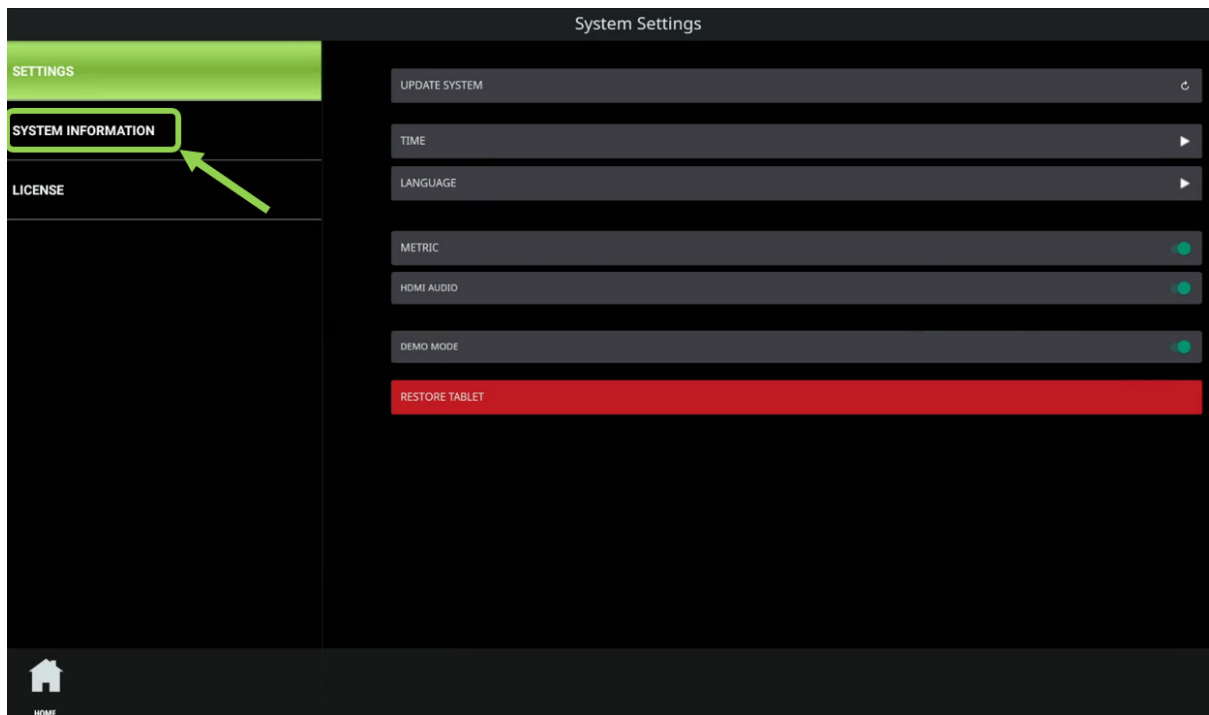

- 7) Confirm that the update was successful.

APP VERSION (Fig. 1)

SERVER VERSION (Fig. 2)

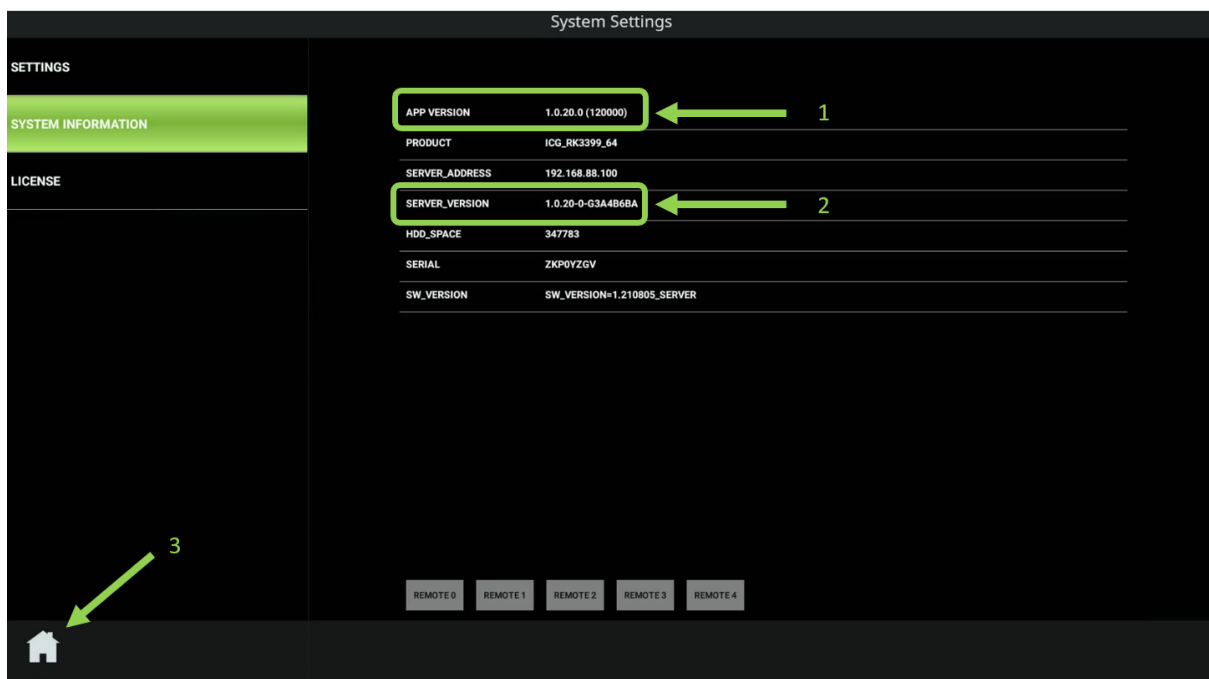

Leave the Settings screen by tapping the home icon (Fig. 3)

- 8) After the update, manually restart the system using the power switch on the back of the system.

CLEANING THE ICG CONNECT SYSTEM

Lightly dampen a section of a microfiber cloth with water and gently wipe the screen, then go over it again with a dry section of the cloth to wipe away any moisture. Avoid getting moisture in any openings like the speaker or mic. If the stain remains, you can also try using a mild soap-and-water solution.

WARRANTY

CYTECH GmbH warrants that all new equipment will be free of manufacturing defects in workmanship and materials, becoming effective on the date of delivery. Parts and components repaired or replaced under the terms of warranty will be warranted for the remainder of the original warranty period only. Warranty may vary by region or country. obtain detailed information on applicable warranty terms and conditions. Please note that warranty does not cover for damages caused by inappropriate use of the MYRIDE CONNECT SYSTEM or any negligent act by the consumer. The manufacturer states that the product was thoroughly tested and found free of failure prior to shipping.

Limited Warranty on MYRIDE CONNECT SYSTEM.

1 year Warranty	Electronic and Mechanical components
-----------------	--------------------------------------

All contents, movies, photos, texts and graphic arts are protected by copyright. They may not be changed without previous written approval neither completely nor in extracts copied, be multiplied or be published. The playback of the content is exclusively permitted using the supplied device. The usage of an external reproducer is only permitted once the relevant program is licensed by the creator. © CYTECH GMBH