



Prescribed for Progress™

ISO1000R/7000R

Machine User Manual



Recumbent Bike

ISO10XXR-BR, ISO10XXR-DOMHUR, ISO10XXR-ERGLN, ISO10XXR-INT, ISO10XXR-INTHUR, ISO10XX-ISBU, ISO10XXR-SA, ISO10XXR-JPHUR, ISO10XXR-JP, ISO70XXR-INT, ISO70XXR-DOMHUR, ISO70XXR-ERGLN, ISO70XXR-(USA), ISO70XXR-BR, ISO70XXR-INTHUR, ISO70XXR-JPHUR, ISO70XXR-ISBU, ISO70XXR-JP

Corporate Headquarters

Columbia Centre III, 9525 Bryn Mawr Avenue, Rosemont, Illinois 60018 • U.S.A.

847.288.3300 • FAX: 847.288.3703

Service phone number: 800.351.3737 (toll-free within U.S.A., Canada)

Global Website: www.lifefitness.com

International Offices

AMERICAS

North America

SCIFIT

5151 S. 110th E. Avenue
Tulsa, OK, 74146 U.S.A.
Toll Free: +1 (800) 745 1373
Email: Service@scifit.com
Service Website: www.scifit.com/service-information

Brazil

Life Fitness Brasil

Av. Rebouças, 2315
Pinheiros
São Paulo, SP 05401-300
BRAZIL
SAC: 0800 773 8282 option 2
Telephone: +55 (11) 3095 5200 option 2
Service Email: suportebr@lifefitness.com
Sales/Marketing Email:
vendasbr@lifefitness.com

Latin America and Caribbean*

Life Fitness, LLC

Columbia Centre III
9525 Bryn Mawr Avenue
Rosemont, IL 60018 U.S.A.
Telephone: (847) 288 3300
Service Email: customersupport@lifefitness.com
Sales/Marketing Email:
commercialsales@lifefitness.com

EUROPE, MIDDLE EAST, and AFRICA (EMEA)

Netherlands and Luxemburg

Life Fitness Atlantic BV

Bijdorpplein 25-31
2992 LB Barendrecht
THE NETHERLANDS
Telephone: (+31) 180 646 666
Service Email: service.benelux@lifefitness.com
Sales/Marketing Email:
marketing.benelux@lifefitness.com

United Kingdom

Life Fitness UK LTD

Queen Adelaide
Ely, Cambs, CB7 4UB
Telephone: General Office (+44) 1353.666017
Customer Support (+44) 1353.665507
Service Email: uk.support@lifefitness.com
Sales/Marketing Email: life@lifefitness.com

Germany, Austria, and Switzerland

Life Fitness Europe GMBH

Neuhofweg 9
85716 Unterschleißheim
GERMANY
Telephone:
+49 (0) 89 / 31775166 Germany
+43 (0) 1 / 6157198 Austria
+41 (0) 848 / 000901 Switzerland
Service Email: kundendienst@lifefitness.com
Sales/Marketing Email: vertrieb@lifefitness.com

Spain

Life Fitness IBERIA

C/Frederic Mompou 5,1ª
08960 Sant Just Desvern Barcelona
SPAIN
Telephone: (+34) 93.672.4660
Service Email: servicio.tecnico@lifefitness.com
Sales/Marketing Email:
info.iberia@lifefitness.com

Belgium

Life Fitness Benelux NV

Parc Industriel de Petit-Rechain
4800 Verviers
BELGIUM
Telephone: (+32) 87 300 942
Service Email: service.benelux@lifefitness.com
Sales/Marketing Email:
marketing.benelux@lifefitness.com

All Other EMEA Countries and Distributor Business EMEA*

Bijdorpplein 25-31
2992 LB Barendrecht
THE NETHERLANDS
Telephone: (+31) 180 646 644
Service Email:
EMEAServiceSupport@lifefitness.com

ASIA PACIFIC (AP)

Japan

Life Fitness Japan, Ltd

4-17-33 Minami Aoyama 1F/B1F
Minato-ku - Tokyo 107-0062
Japan
Telephone: (+81) 0120.114.482
Fax: (+81) 03-5770-5059
Service Email: service.lfj@lifefitness.com
Sales/Marketing Email:
sales@lifefitnessjapan.com

Hong Kong

Life Fitness Asia Pacific LTD

32/F, Global Trade Square
21 Wong Chuk Hang Road
Hong Kong
Telephone: (+852) 2575.6262
Service Email: Service.HK@lifefitness.com
Sales/Marketing Email:
hongkong.sales@lifefitness.com

All Other Asia Pacific countries and distributor business Asia Pacific*

32/F, Global Trade Square
21 Wong Chuk Hang Road
Hong Kong
Telephone: (+852) 2575.6262
Fax: (+852) 2575.6894
Service Email: Service.AP@lifefitness.com
Sales/Marketing Email:
Marketing.HK.Asia@lifefitness.com

*Also check www.SCIFIT.com for local representation or distributor/dealer

* Order online 24/7 at www.SCIFIT.com

User and Service Documents Link

<https://lfworld.lifefitness.com>

Additional information is available online using the link above.

تتوفر معلومات إضافية على الإنترنت باستخدام الرابط أعلاه.

点击上面的链接可在线获取更多信息。

Flere oplysninger er tilgængelige online gennem linket ovenfor.

Bijkomende informatie is online beschikbaar via bovenstaande link.

Vous trouverez plus d'informations en ligne à l'aide du lien ci-dessus.

Zusätzliche Informationen finden Sie online über den oben angegebenen Link.

Ulteriori informazioni sono disponibili online utilizzando il link sopra riportato.

追加情報は上記リンクを使用してオンラインで利用可能です。

상기 링크를 통해 온라인에서 추가 정보를 볼 수 있습니다.

Informações adicionais estão disponíveis on-line, através do link acima.

Дополнительная информация доступна в интернете по ссылке, указанной выше.

Mediante el enlace anterior podrá acceder a información adicional en línea.

Ytterligare information finns online genom att använda länken ovan.

İnternet üzerinden daha fazla bilgi edinmek için yukarıdaki bağlantıyı kullanabilirsiniz.

هناك معلومات إضافية متاحة على الإنترنت باستخدام الرابط أعلاه.

Informazio osagarria eskuragarri dago goiko estekaren bidez.

Допълнителна информация можете да намерите онлайн, като използвате връзката по-горе.

Mitjançant l'enllaç anterior podreu accedir a informació addicional en línia.

使用上面的連結線上提供額外資訊。

Dodatne informacije možete pronaći na internetu sljedeći vezu iznad.

ከላይ የተቀመጠውን አገናኝ(ሊንክ) በመጠቀም መረጃዎች አንላይን ያገኛሉ።

Lisätietoja on saatavissa verkosta käyttämällä yllä olevaa linkkiä.

Wubetumi anya nsem afoforo aka ho wo websait so denam asem a ewo atifi ho a wubemia so so.

Πρόσθετες πληροφορίες είναι διαθέσιμες ονλάιν χρησιμοποιώντας το σύνδεσμο παραπάνω.

מידע נוסף הוא זמין באתר האינטרנט באמצעות הקישור לעיל.

További információ elérhető online, a fenti hivatkozás segítségével.

Viðbótarupplýsingar eru fáanlegar á netinu með því að smella á tengilinn hér fyrir ofan.

Plus indicium per superum situm potes invenire.

മുകളിലുള്ള ലിങ്ക് ഉപയോഗിച്ച് ഓൺലൈനിൽ കൂടുതൽ വിവരങ്ങൾ ലഭ്യമാണ്.

Ytterligere informasjon er tilgjengelig på nettet via linken ovenfor.

Dodatkowe informacje są dostępne online pod powyższym odnośnikiem.

Informações adicionais estão disponíveis online a usar o link acima.

Informații suplimentare sunt disponibile online, utilizând link-ul de mai sus.

Dodatne informacije dostupne su na mreži putem gornjeg linka.

Ďalšie informácie sú dostupné online na vyššie uvedenom odkaze.

Table of Contents

Safety

Introduction.....	4
Safety Information.....	4

Service and Technical Data

Maintenance.....	6
------------------	---

Adjustments

Machine Relocation.....	7
Machine Power Up.....	9
Seat Mounting.....	10

Heart Rate

Heart Rate Tracking.....	11
--------------------------	----

HUR-ERGOLINE

Connecting Port Location.....	12
Console Cable Connections.....	12

Biomechanical Positioning

Machine Entry.....	13
Initiating a Workout.....	13
Exit The Machine.....	13

Specifications

Specifications.....	14
Safety Perimeter.....	14

Warranty

What is Covered.....	15
Who is Covered.....	15
How long is it covered.....	15
Who Pays Transportation and Insurance For Service.....	15
What We Will Do To Correct Covered Defects.....	15
What is not covered.....	15
What you must do.....	15
How to get replacement parts and service.....	16
Exclusive Warranty.....	16
Changes in Warranty Not Authorized.....	16
Effects of State Laws.....	16

Safety

Introduction

Thank you for your purchase of this SCIFIT exercise machine. We have incorporated the finest technology and ergonomic design into this machine to assist you in achieving your fitness goals.

This SCIFIT machine is designed for class “S” (commercial) and class “A” (high accuracy) and class “II a” (medical directive) applications. The intended uses are for general health and wellness, cardio & pulmonary rehabilitation, sports medicine, physical therapy, physical conditioning and strength training. SCIFIT equipment are suitable for placement in medical, wellness, fitness, and recreational facilities. The machine has 191 levels of console controlled resistance, which ensures that users of all fitness levels will be able to get a challenging but not overwhelming workout.

To review the latest guidelines and recommendations, visit the American College of Sports Medicine website: www.acsm.org

FCC Warning - Possible Radio / Television Interference

This equipment has been tested and found to comply with the limits for a Class A digital device, pursuant to part 15 of the FCC rules. These limits are designed to provide reasonable protection against harmful interference when the equipment is operated in a commercial environment. This equipment generates, uses and can radiate radio frequency energy, and if not installed and used in accordance with the instruction manual, may cause harmful interference to radio communications. Operation of this equipment in a residential area is likely to cause harmful interference in which case the user will be required to correct the interference at his own expense.

Safety Information

 **DANGER:** To reduce the risk of electrical shock or injury from moving parts, always unplug the machine before cleaning or attempting any maintenance activity.

 **WARNING:** Health-related injuries may result from incorrect or excessive use of exercise equipment. It is **STRONGLY** recommended seeing a physician for a complete medical exam before undertaking an exercise program, particularly if the user has a family history of high blood pressure or heart disease, is over the age of 45, smokes, has high cholesterol, is obese, or has not exercised regularly in the past year. If, at any time while exercising, the user experiences faintness, dizziness, pain, or shortness of breath, he or she must stop well immediately.

 **WARNING:** To reduce the risk of burns, fire, electrical shock, or injury, it is imperative to connect each product to a properly grounded electrical outlet.

 **WARNING:** Heart rate monitoring systems may be inaccurate. Over exercising may result in serious injury or death. If you feel faint, stop exercising immediately.

 **WARNING:** Allow a distance of 40 in. (1m) between the widest part of the machine and other objects on either side. Provide 40 in (1m) between the front or rear of the SCIFIT machine to any other objects.

 **WARNING:** This product can expose you to chemicals including Ethylbenzene, which is known to the State of California to cause cancer, and Toluene, which is known to the State of California to cause birth defects or other reproductive harm. For more information go to <http://www.P65Warnings.ca.gov>

 **CAUTION:** Any changes or modifications to this equipment could void the product warranty.

- Read all warnings and instructions on each product prior to using your exercise machine. Save these instructions for future reference.
- If warnings are missing or damaged, please contact customer service immediately for replacement warning labels. Warning labels are shipped with every product and should be installed before the product is used. SCIFIT is not responsible for missing or damaged warning labels.
- Use the exercise machine only for its intended purposes as described in this manual. Do not use attachments not recommended by the manufacturer.
- Never insert objects into any opening in these products. If an object should drop inside, turn off the power, unplug the power cord from the outlet, and carefully retrieve it. If the item cannot be reached, contact customer support services..
- This machine is intended for indoor use only. Do not place in direct sunlight, high humidity or where water is present (i.e. pool or spa areas).

- This machine is not intended for use by persons with reduced physical sensory or mental capabilities, or lack of experience and knowledge, unless they have been given supervision or instruction concerning use of the machine by a person responsible for their safety. Keep children under the age of 14 away from this machine.
- Never operate the machine with the air openings blocked. Keep air openings free of lint, hair, or any other obstructing material.
- Never place liquids of any type directly on the unit, except in an accessory tray or holder. Containers with lids are recommended. Do not use these products in bare feet. Always wear shoes. Wear shoes with rubber or high-traction soles. Do not use shoes with heels, leather soles, cleats or spikes. Make sure no stones are embedded in the soles.
- Keep all loose clothing, shoelaces, and towels away from moving parts.
- Do not reach into, or underneath, the unit or tip it on its side during operation.
- Do not allow other people to interfere in any way with the user or equipment during a workout.
- The product should never be left unattended when plugged in. Disconnect from the electrical outlet when not in use, and before putting on or taking off parts.
- Free standing equipment shall be installed on a stable and leveled surface.
- Do not stand or sit on plastic shrouds.
- Use caution when mounting or dismounting the machine. Use the stationary handlebar whenever additional stability is required.

Service and Technical Data

Maintenance

Component	Action	When
Upholstery	Clean With a Damp Cloth	Daily
Base Roller Track	Clean With a Damp Cloth	Weekly
Battery	Refer to "Rotary CNSL Prog. Manual" For battery Check Instruct.	Monthly
Chain (ISO7000R models)	General Purpose Chain Lubricant	Every 6 Months

ATTENTION: Contact your local waste management agency for specific requirements concerning recycling and disposal locations of batteries.

Adjustments

Machine Relocation

1. Push down on the yellow foot lever on either side of the seat post and hold, then slide the seat off the base frame.

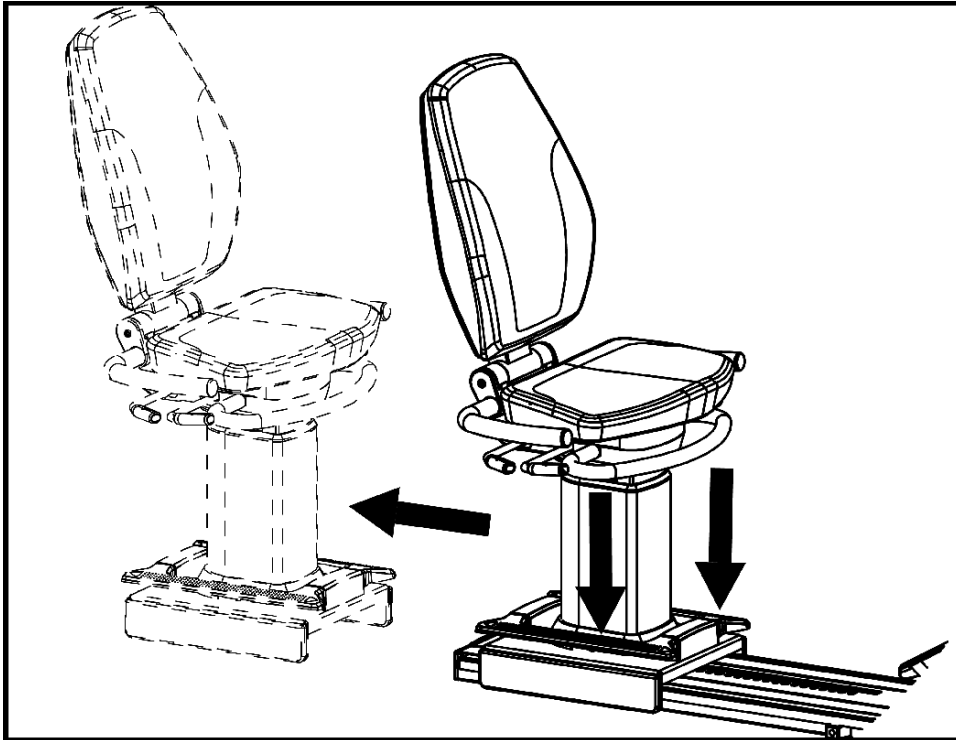

2. Grab the lift handle at the rear of the base frame.

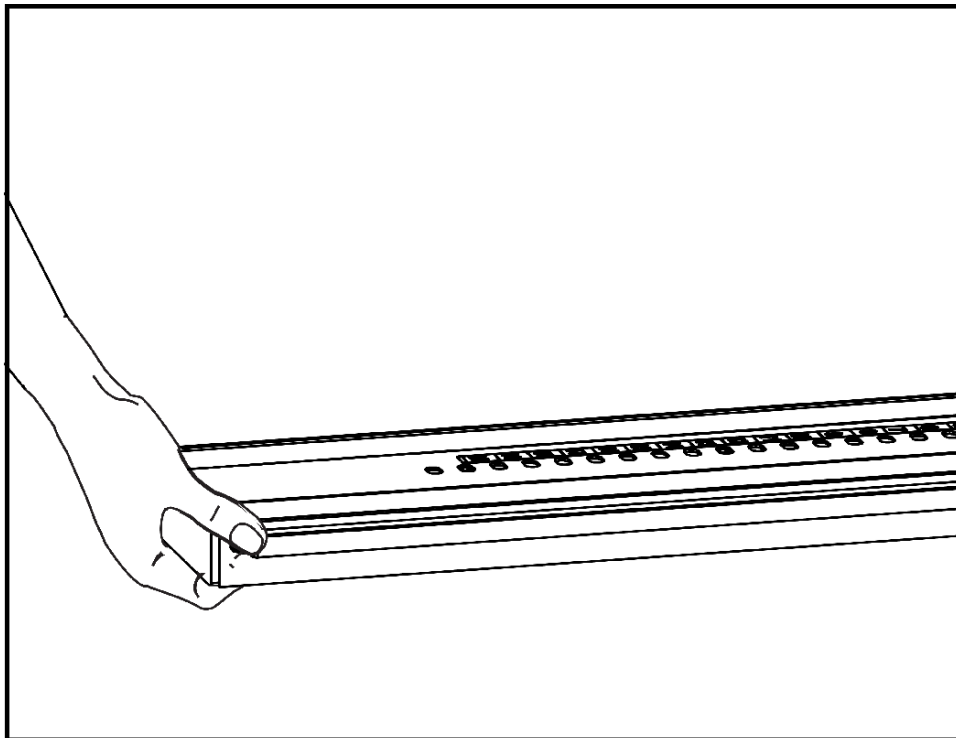

3. Carefully lift the machine until the front wheels touch the ground, then move the machine forward.

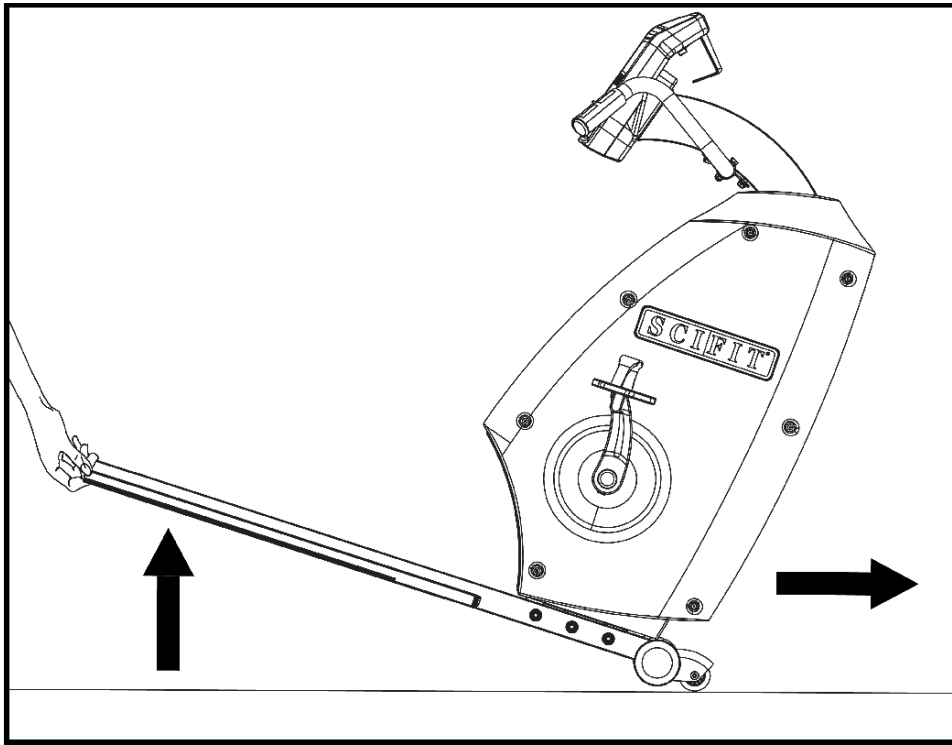

4. When a location is found, use the adjustable end caps on both sides of the frame to level the machine.

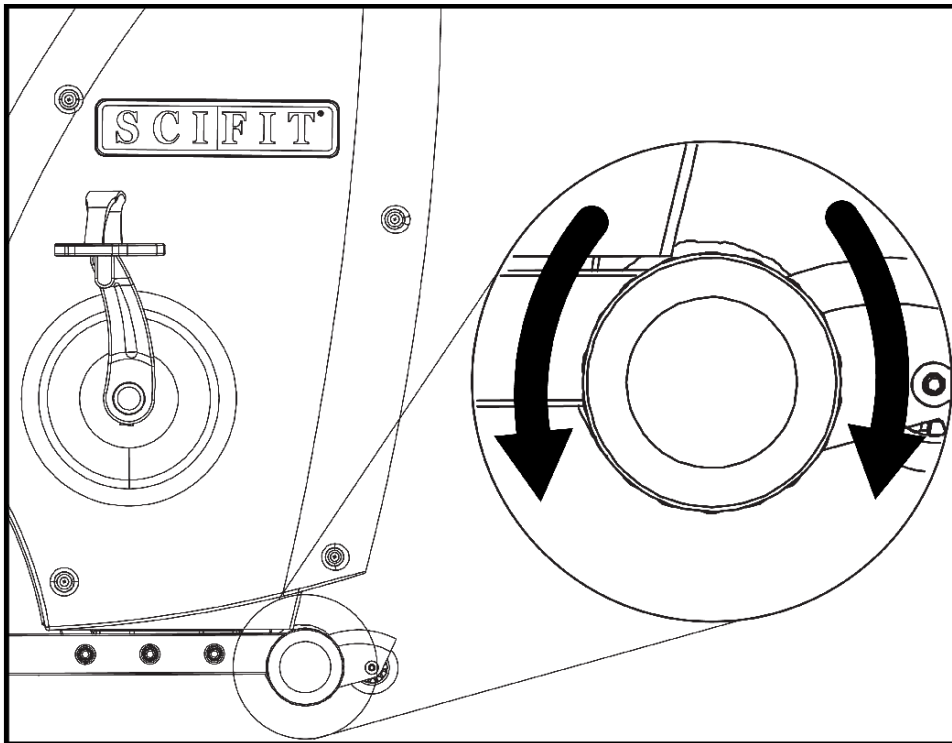

⚠ WARNING: Two people required.

⚠ WARNING: Not placing the machine on a stable and level surface may result in injury to yourself and others.

Machine Power Up

Option 1: Continually rotate the lower foot pedals to keep the console powered-up.

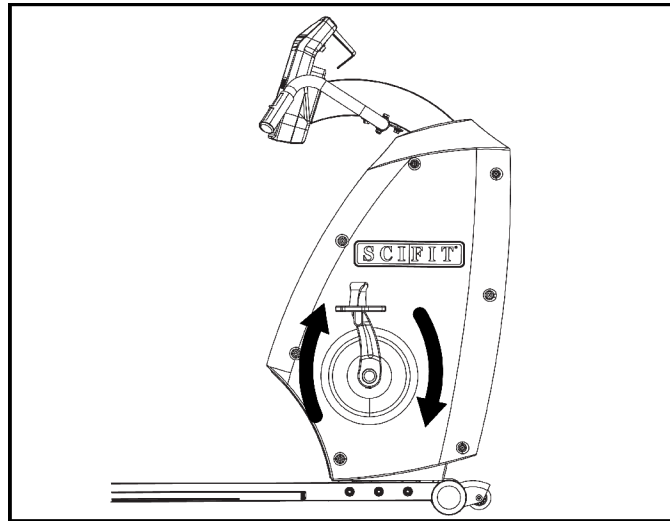

Option 2: Connect either domestic or International power supply to the machine for continuous power.

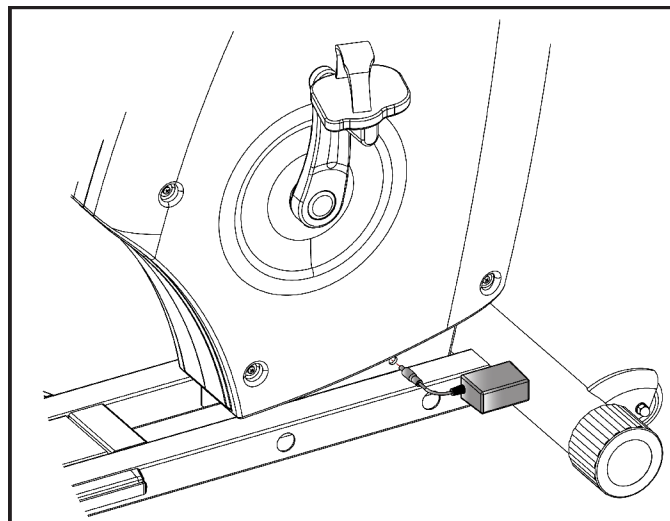
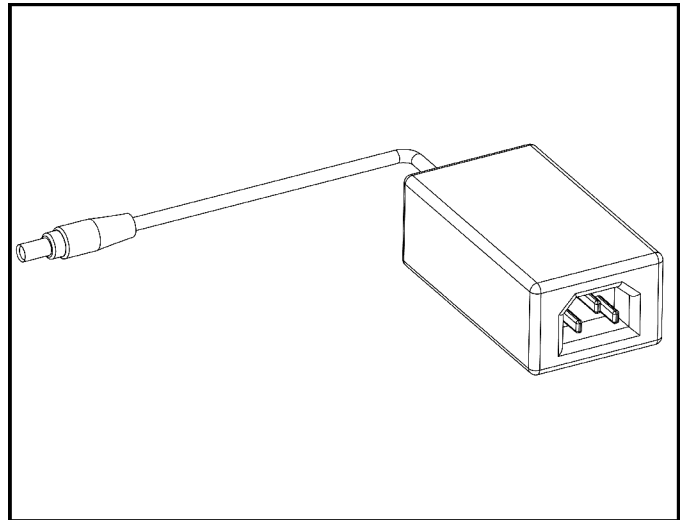
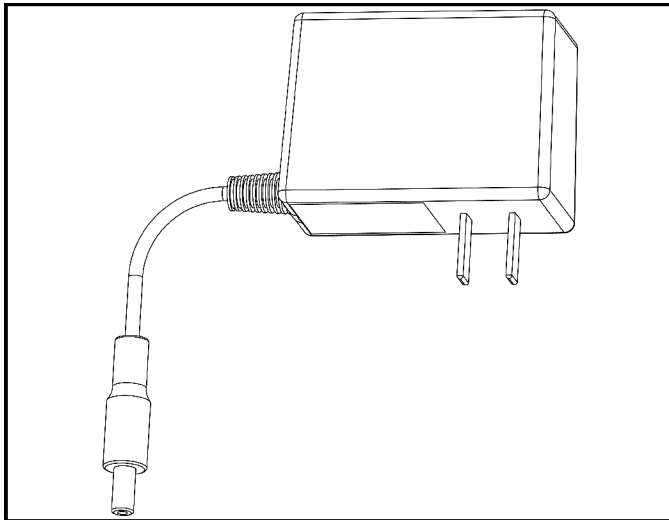

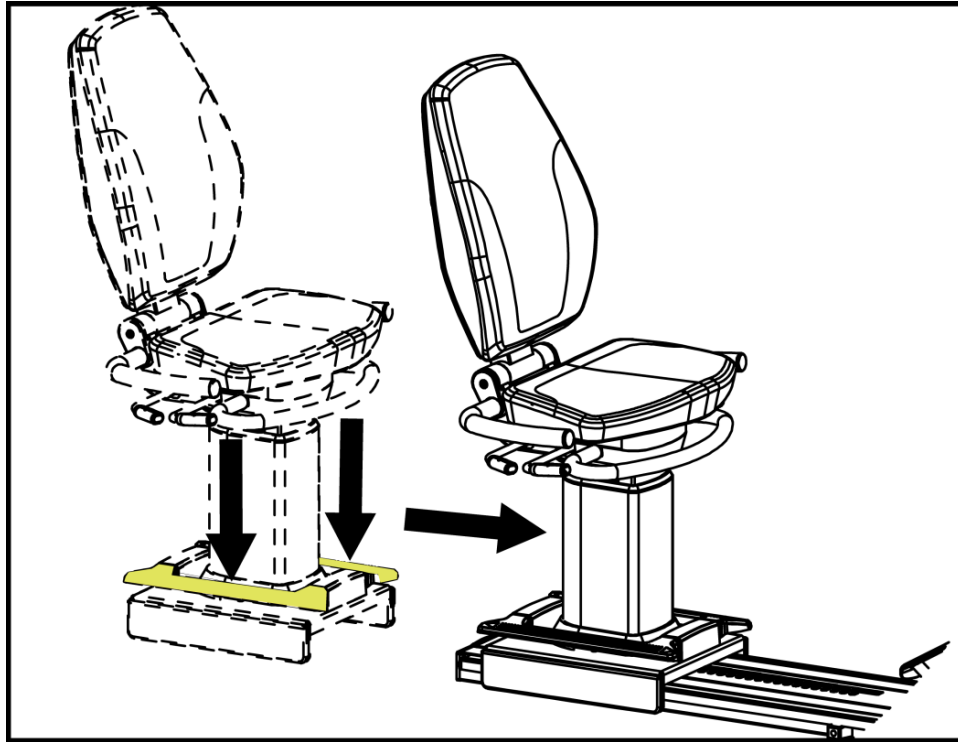

Heart Rate

Heart Rate Tracking

OPTION 1: Contact Heart Rate

The user can place their hands on the metal contact plates located on the ends of the handlebar during the workout. After a short period of time the heart symbol will begin to blink and the user heart rate will appear.

NOTE: Keep hands still to receive a consistent reading.

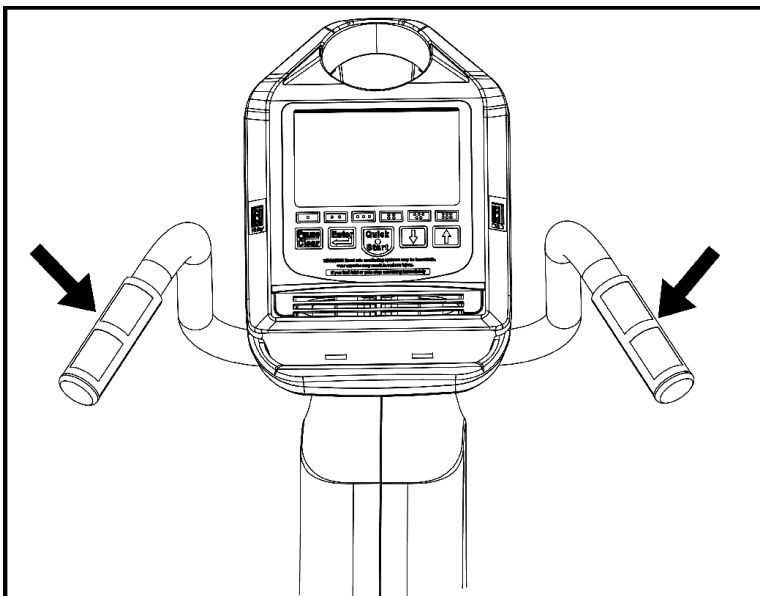

OPTION 2: Wireless Belt Transmitter

During the workout, the user's heart rate will register on the console via a wireless chest strap that makes direct contact with the body.

NOTE: Do not grip the metal contact plates on the handlebar during the workout, this will over ride the chest belt transmission.

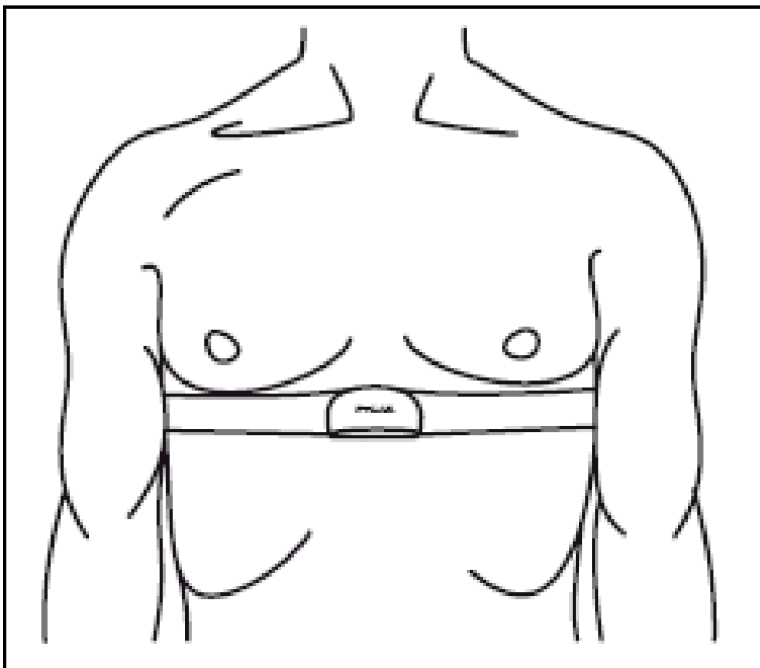

Connecting Port Location

The port connector is located in the front area of the right side cover.

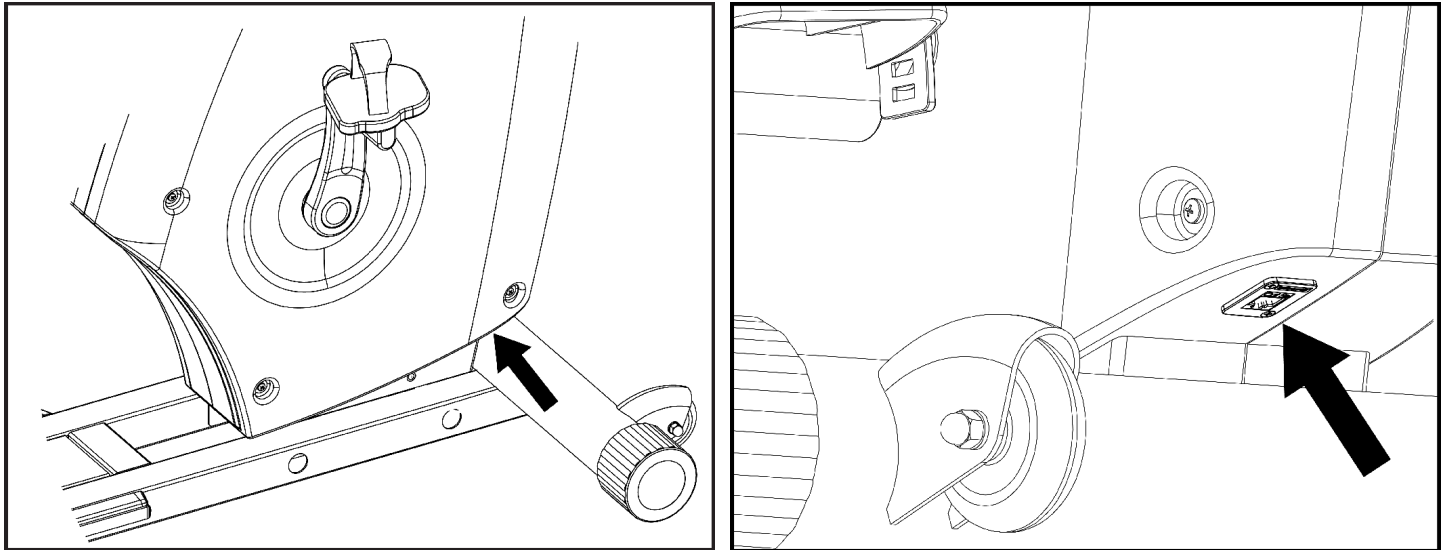

Console Cable Connections

1. The HUR/ERGOLINE cables are labeled with a "COMM" decal. Connect the "COMM" labeled cable coming out of the machine to the "COMM" labeled cable that is attached to a RJ45 female to female connector coming out of the back of the console.
2. Attach the "Non-labeled" cable coming out of the machine to "P6" on the back of the console.

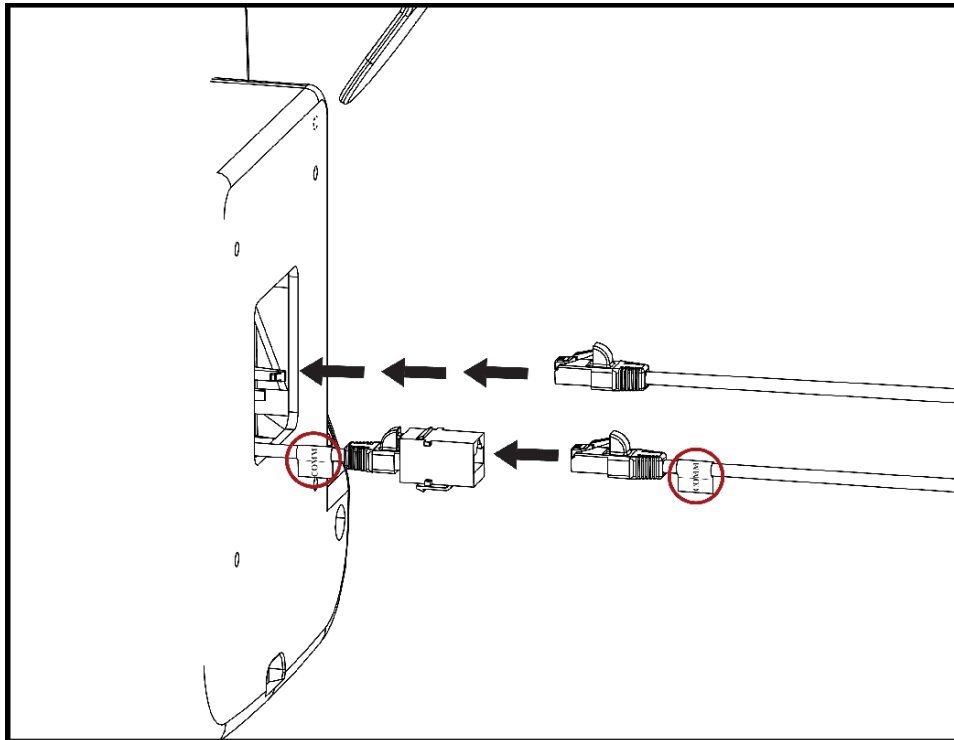

3. After connecting the cables, attach the console to the machine with the provided securing hardware.

Biomechanical Positioning

Machine Entry

1. Choose one of the following to position seat for entry.
 - Press and hold the yellow foot lever located on either side of the seat base (see Seat System manual), then move the seat back to allow sufficient entry space and release the foot lever. You may grab the handles on either side of the console to stabilize yourself and sit on the seat.
 - Lift upward on the yellow swivel lever (Premium only) located on either side of the seat (see Seat System manual) and rotate the seat 90 degrees to the right or left to access the bottom seat pad and release, then sit down and again lift upward on the swivel lever and rotate back into the original position.
2. Position the seat forward or backward to a comfortable location using the yellow foot lever, then release the lever allowing for a slight knee bend when placing your feet on the foot pads or pedals.
3. Adjust the height (Premium only) of the seat using the yellow bar on the front of the seat (see Seat System manual) to obtain a comfortable position.

Initiating a Workout

1. Place your feet on the lower foot pedals, then grab the handlebars and begin pushing on the foot pedals continuously to keep the console powered up.

NOTE: The AC adapter may also be connected to the machine to keep the console continuously powered-up.
2. Select the workout program preferred (see Console Program manual) and begin the workout.

Exit The Machine

Choose one of the following ways to exit the machine.

1. Press and hold the yellow foot lever located on either side of the base of the seat base, then move the seat back to allow sufficient exit space and release the foot lever. Carefully lift yourself up and exit the machine.
2. Lift upward on the yellow swivel lever (Premium only) located on either side of the seat and rotate the seat 90 degrees right or left, then release. Carefully lift yourself upward and exit the machine.



Specifications

Specifications

ISO1000R/ISO7000R

Weight	ISO1000R - 226 lbs (103 kg) / ISO7000R - 234 lbs (106 kg)
Maximum User Weight	Premium - 450 lbs (204 kg) / Standard - 500 lbs (227 kg) /Bariatric - 600 lbs (272 kg)
Power	Self generating w/auto recharge battery back-up. Optional AC adapter available.
Resistance System	ISO1000R - Forward Only / ISO7000R - Bi-Directional
Programs	Manual, Fit-Quik, Constant Workout, ISO-Strength, 7 Pre-programmed Hills profiles, Heart Rate, Power Fit Test, Power Fit Training, Heart Fit Test, Heart Fit Training, Stress Test and Random.
Accuracy	Class A
Length	58" (147 cm)
Height	55" (140 cm)
Width	27" (69 cm)

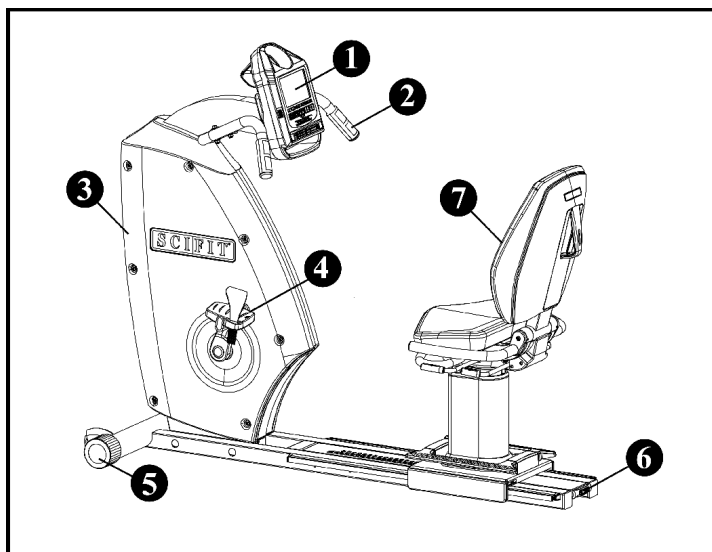

1	Intelli-Fit Console
2	Contact Heart Rate Grips
3	ISO1000R - Belt Driven / ISO7000R - Chain Driven
4	Lower Foot Pedals
5	Leveling End Caps
6	Lift Handle
7	Seat System - Premium / Standard / Bariatric

Safety Perimeter

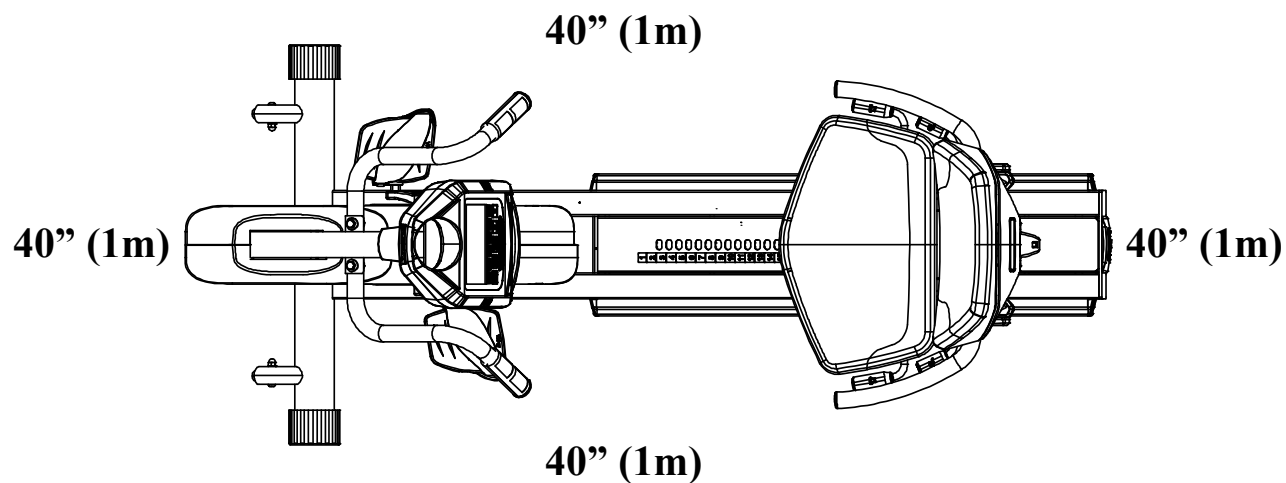

Warranty

What is Covered

This Life Fitness Family of Brands commercial exercise equipment product is warranted to be free of all defects in material and workmanship.

Who is Covered

The original purchaser or any person receiving the product as a gift from the original purchaser.

How long is it covered

All coverage is provided by specific Product according to the guidelines listed on the chart below.

Item	6 Months	1 Year	2 Years	3 Years	5 Years
Frame					X
Electrical				X	
Mechanical				X	
Labor		X			
Cranks/Drive Syst. (Latitude Only)			X		
Upholstery, Seats, Grips, Walk belts, Decks		X			
Battery		X			
High Wear Items (Heart rate Straps, Pedal Straps)	X				

Who Pays Transportation and Insurance For Service

If the Product or any covered part must be returned to a service facility for repairs, We, Life Fitness Family of Brands, will pay all transportation and insurance charges for the first year. You are responsible for transportation and insurance charge after the first year.

What We Will Do To Correct Covered Defects

We will ship to you any new or rebuilt replacement part or component, or at our option, replace the Product. Such replacement parts are warranted for the remaining portion of the original warranty period.

What is not covered

Any failures or damage caused by unauthorized service, misuse, accident, negligence, improper assembly or installation, debris resulting from any construction activities in the Product's environment, rust or corrosion as a result of the Product's location, alterations or modifications without our written authorization or by failure on your part to use, operate and maintain the Product as set out in your Operation Manual ("Manual").

One type RJ45 interchangeable Network ready and Fitness Entertainment port is supplied with the Product. This port complies with the FitLinxx CSAFE specification dated August 4, 2004 stating: 4.75VDC to 10VDC; maximum current of 85mA. Any Product damage caused by a load exceeding this FitLinxx CSAFE specification is not covered by warranty.

All terms of this warranty are void if this product is moved beyond the continental borders of the United States of America (excluding Alaska, Hawaii and Canada) and are then subject to the terms provided by that country's local authorized *SCIFIT* representative.

Detailed warranty guidelines are available at: <http://www.scifit.com/service-information/>.

What you must do

Register your Product online at <http://www.scifit.com/warranty-registration-2/>.

Retain proof of purchase; use, operate and maintain the Product as specified in the Manual; notify Customer Support Services of any defect within 10 days after discovery of the defect; if instructed, return any defective part for replacement or, if necessary, the entire Product for repair.

How to get replacement parts and service

Refer to the front of this manual for your local service contact information. Reference your name, address and the serial number of your Product. They will tell you how to get a replacement part, or, if necessary, arrange for service where your Product is located.

Exclusive Warranty

THIS LIMITED WARRANTY IS IN LIEU OF ALL OTHER WARRANTIES OF ANY KIND EITHER EXPRESSED OR IMPLIED, INCLUDING BUT NOT LIMITED TO THE IMPLIED WARRANTIES OF MERCHANTABILITY AND FITNESS FOR A PARTICULAR PURPOSE, AND ALL OTHER OBLIGATIONS OR LIABILITIES ON OUR PART. We neither assume nor authorize any person to assure for us any other obligation or liability concerning the sale of this Product. Under no circumstances shall we be liable under this warranty, or otherwise, of any damage to any person or property, including any lost profits or lost savings, for any special, indirect, secondary, incidental or consequential damages of any nature arising out of the use of or inability to use this Product. Some states do not allow the exclusion or limitation of implied warranties or of liability for incidental or consequential damages, so the above limitations or exclusions may not apply to you. Warranty coverages and terms may differ outside the United States. Please contact the Life Fitness office servicing your country (contact information found at the front of this manual) or visit the applicable local Life Fitness website to receive the specific warranty information for your country.

Changes in Warranty Not Authorized

No one is authorized to change, modify or extend the terms of this limited warranty.

Effects of State Laws

This warranty gives you specific legal rights, and you may have other rights which vary from state to state and country by country.



Prescribed for Progress™