

# PL-GLD Belt Kit

## Kit Contents: 1020462-0001

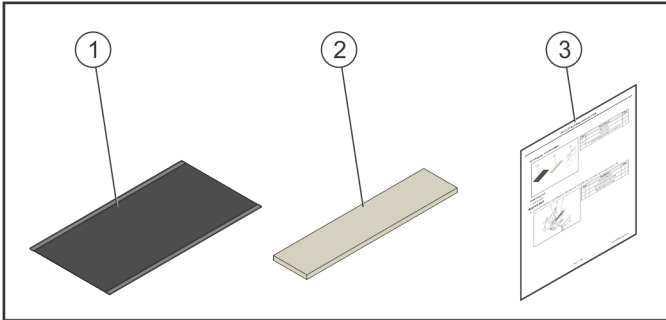

Item	Description	Qty.
1	Cover	1
2	Padding	1
3	Kit Instructions	1

## Tools Required

- 3/4" Wrench

## Installation Instructions

1. Using a 3/4 inch wrench, loosen and remove the hex bolt, backing washer and belt.

**Note:** Save hardware for re-installation.

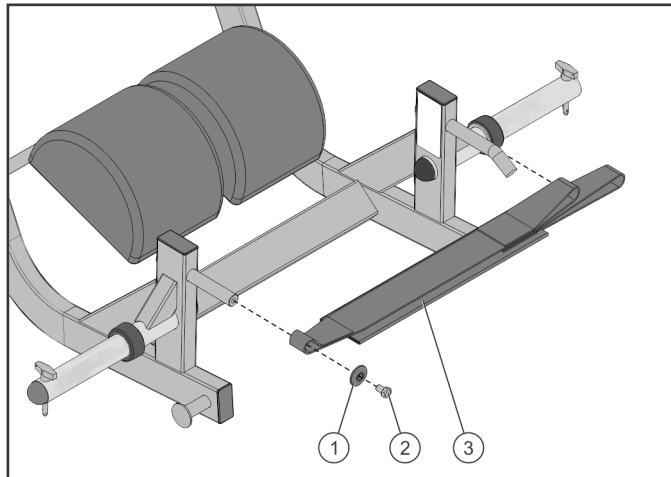

Item	Description	Qty.
1	Backing Washer	1
2	1/2 IN-13 X 0.75 Hex Bolt	1
3	Belt	1

2. Flip belt over and place on a flat surface.
3. Peel protective backing off padding so adhesive is exposed.
4. With padding centered and adhesive side facing down, place padding onto the belt, pressing firmly along the padding's surface.
5. Flip belt back over so padding is facing down.
6. With hook and loop side of cover facing up, lay cover on a flat surface.

7. Center belt and place onto the cover.

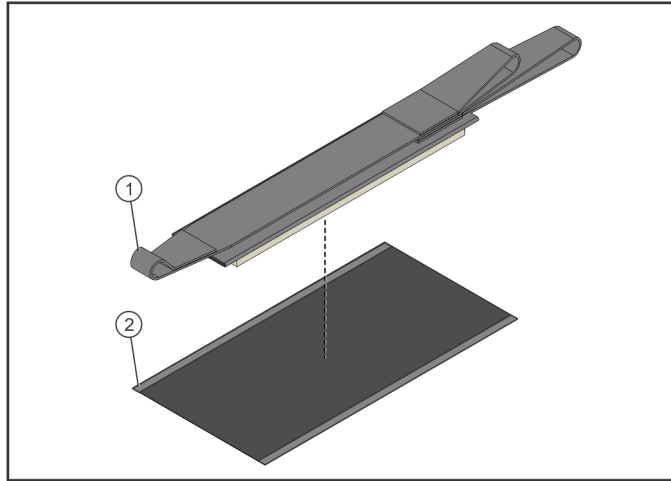

Item	Description	Qty.
1	Belt	1
2	Cover	1

8. Tightly fold the edges of the cover over the belt, then press the hook and loop edges together until fastened.

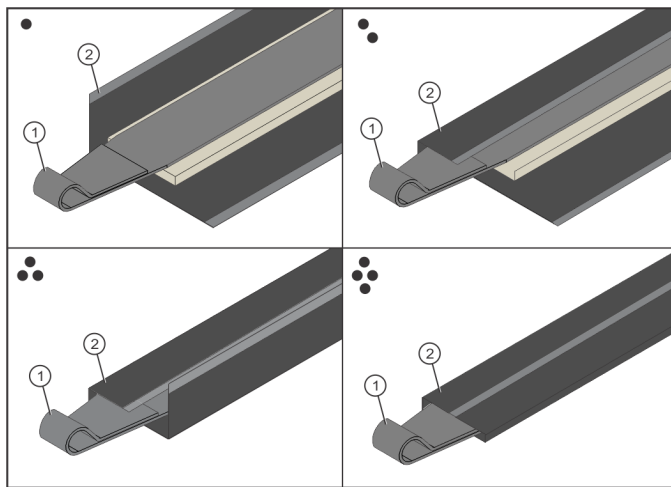

Item	Description	Qty.
1	Cover	1
2	Belt	1

9. Install belt (padded side facing down), hex bolt and backing washer using a 3/4 inch wrench.

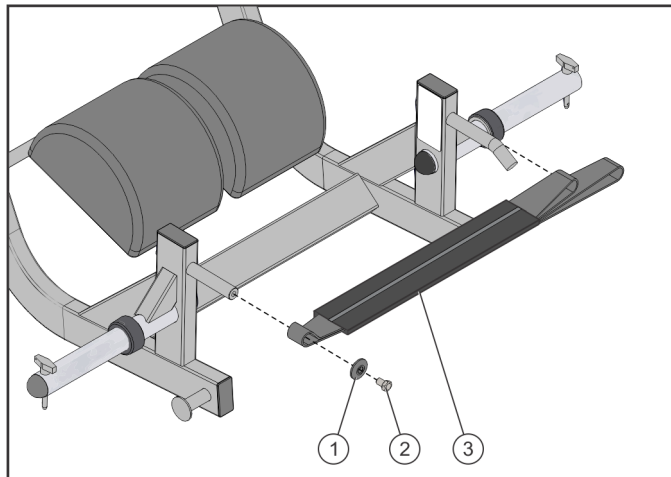

Item	Description	Qty.
1	Backing Washer	1
2	1/2 IN-13 X 0.75 Hex Bolt	1
3	Belt	1



Tighten hardware to 20-25 ft-lb (27.1-33.9 Nm).

10. Test unit for proper operation.