

Activate Treadmill

OST Assembly Instructions



Corporate Headquarters

10601 W Belmont Ave, Franklin Park, IL 60131 • U.S.A.
847.288.3300 • FAX: 847.288.3703
Service phone number: 800.351.3737 (toll-free within U.S.A., Canada)
Global Website: www.lifefitness.com

International Offices

AMERICAS

North America

Life Fitness, LLC

10601 W Belmont Ave
Franklin Park, IL 60131 U.S.A.
Telephone: (847) 288 3300
Service Email:
customersupport@lifefitness.com
Sales/Marketing Email:
commercialsales@lifefitness.com

Brazil

Life Fitness Brasil

Av. Rebouças, 2315
Pinheiros
São Paulo, SP 05401-300
BRAZIL
SAC: 0800 773 8282 option 2
Telephone: +55 (11) 3095 5200 option 2
Service Email: suportebr@lifefitness.com
Sales/Marketing Email:
vendasbr@lifefitness.com

Latin America and Caribbean*

Life Fitness, LLC

10601 W Belmont Ave
Franklin Park, IL 60131 U.S.A.
Telephone: (847) 288 3300
Service Email:
customersupport@lifefitness.com
Sales/Marketing Email:
commercialsales@lifefitness.com

EUROPE, MIDDLE EAST, and AFRICA (EMEA)

Netherlands and Luxemburg

Life Fitness Atlantic BV

Bijdorpplein 25-31
2992 LB Barendrecht
THE NETHERLANDS
Telephone: (+31) 180 646 666
Service Email:
service.benelux@lifefitness.com
Sales/Marketing Email:
marketing.benelux@lifefitness.com

United Kingdom

Life Fitness UK LTD

Queen Adelaide
Ely, Cambs, CB7 4UB
Telephone: General Office (+44)
1353.666017
Customer Support (+44) 1353.665507
Service Email: uk.support@lifefitness.com
Sales/Marketing Email: life@lifefitness.com

Germany, Austria, and Switzerland

Life Fitness Europe GMBH

Neuhofweg 9
85716 Unterschleißheim
GERMANY
Telephone:
+49 (0) 89 / 31775166 Germany
+43 (0) 1 / 6157198 Austria
+41 (0) 848 / 000901 Switzerland
Service Email:
kundendienst@lifefitness.com
Sales/Marketing Email:
vertrieb@lifefitness.com

Spain

Life Fitness IBERIA

C/Frederic Mompou 5,1ª^a
08960 Sant Just Desvern Barcelona
SPAIN
Telephone: (+34) 93.672.4660
Service Email:
servicio.tecnico@lifefitness.com
Sales/Marketing Email:
info.iberia@lifefitness.com

Belgium

Life Fitness Benelux NV

Parc Industriel de Petit-Rechain
4800 Verviers
BELGIUM
Telephone: (+32) 87 300 942
Service Email:
service.benelux@lifefitness.com
Sales/Marketing Email:
marketing.benelux@lifefitness.com

All Other EMEA Countries and Distributor Business EMEA*

Bijdorpplein 25-31
2992 LB Barendrecht
THE NETHERLANDS
Telephone: (+31) 180 646 644
Service Email:
EMEAServiceSupport@lifefitness.com

ASIA PACIFIC (AP)

Japan

Life Fitness Japan, Ltd

4-17-33 Minami Aoyama 1F/B1F
Minato-ku - Tokyo 107-0062
Japan
Telephone: (+81) 0120.114.482
Fax: (+81) 03-5770-5059
Service Email: service.lfj@lifefitness.com
Sales/Marketing Email:
sales@lifefitnessjapan.com

Hong Kong

Life Fitness Asia Pacific LTD

32/F, Global Trade Square
21 Wong Chuk Hang Road
Hong Kong
Telephone: (+852) 2575.6262
Service Email: Service.HK@lifefitness.com
Sales/Marketing Email:
hongkong.sales@lifefitness.com

All Other Asia Pacific countries and distributor business Asia Pacific*

32/F, Global Trade Square
21 Wong Chuk Hang Road
Hong Kong
Telephone: (+852) 2575.6262
Fax: (+852) 2575.6894
Service Email: Service.AP@lifefitness.com
Sales/Marketing Email:
Marketing.HK.Asia@lifefitness.com

*Also check www.lifefitness.com for local representation or distributor/dealer

User and Service Documents Link

<https://lifefitness9512.zendesk.com/hc/en-us>

<https://www.lftechsupport.com/web/document-library/documents>

Additional information is available online using the links above.

تتوفر معلومات إضافية على الإنترنت باستخدام الرابط أعلاه.

点击上面的链接可在线获取更多信息。

Flere oplysninger er tilgængelige online gennem linket ovenfor.

Bijkomende informatie is online beschikbaar via bovenstaande link.

Vous trouverez plus d'informations en ligne à l'aide du lien ci-dessus.

Zusätzliche Informationen finden Sie online über den oben angegebenen Link.

Ulteriori informazioni sono disponibili online utilizzando il link sopra riportato.

追加情報は上記リンクを使用してオンラインで利用可能です。

상기 링크를 통해 온라인에서 추가 정보를 볼 수 있습니다.

Informações adicionais estão disponíveis on-line, através do link acima.

Дополнительная информация доступна в интернете по ссылке, указанной выше.

Mediante el enlace anterior podrá acceder a información adicional en línea.

Ytterligare information finns online genom att använda länken ovan.

İnternet üzerinden daha fazla bilgi edinmek için yukarıdaki bağlantıyı kullanabilirsiniz.

هناك معلومات إضافية متاحة على الإنترنت باستخدام الرابط أعلاه.

Informazio osagarria eskuragarri dago goiko estekaren bidez.

Допълнителна информация можете да намерите онлайн, като използвате връзката по-горе.

Mitjançant l'enllaç anterior podreu accedir a informació addicional en línia.

使用上面的連結線上提供額外資訊。

Dodatne informacije možete pronaći na internetu sljedeći vezu iznad.

ከላይ የተመጠውን አገናኝ(ሊንክ) በመጠቀም መረጃዎች አንላይን ያገኛሉ።

Lisätietoja on saatavissa verkosta käyttämällä yllä olevaa linkkiä.

Wubetumi anya nsem afoforo aka ho wa websait so denam asem a ewa atifi ho a wubemia so so.

Πρόσθετες πληροφορίες είναι διαθέσιμες online χρησιμοποιώντας το σύνδεσμο παραπάνω.

מידע נוסף אפשר לקבל באינטרנט באמצעות הקישור לעיל.

További információ elérhető online, a fenti hivatkozás segítségével.

Viðbótarupplýsingar eru fáanlegar á netinu með því að smella á tengilinn hér fyrir ofan.

Plus indicium per superum situm potes invenire.

മുകളിലുള്ള ലിങ്ക് ഉപയോഗിച്ച് ഓൺലൈനിൽ കൂടുതൽ വിവരങ്ങൾ ലഭ്യമാണ്.

Ytterligere informasjon er tilgjengelig på nettet via linken ovenfor.

Dodatkowe informacje są dostępne online pod powyższym odnośnikiem.

Informações adicionais estão disponíveis online a usar o link acima.

Informații suplimentare sunt disponibile online, utilizând link-ul de mai sus.

Dodatne informacije dostupne su na mreži putem gornjeg linka.

Ďalšie informácie sú dostupné online na vyššie uvedenom odkaze.

Table of Contents

Getting Started

Safety Instructions.....	4
Set-Up.....	6

Product Overview

Product Features.....	9
Mounting and Dismounting the Treadmill.....	9
User Position.....	9
Using and Testing the Emergency Stop System.....	9

Assembly

Component and Hardware List.....	10
Tools Required.....	11
Remove Motor Cover.....	11
Install Uprights.....	12
Install Front Crossbar.....	13
Install Bridge.....	14
Tighten Upper Hardware.....	15
Tighten Lower Hardware.....	15
Install Console Cables and Grommets.....	16
Install Upper Dashboard Tray.....	17
Install Console.....	17
Console Connections.....	18
Install Lower Dashboard Tray.....	18
Install Rear End Caps.....	18
Install Motor Cover.....	19
Install Front End Caps.....	19
Install Power Cord.....	19

Service and Technical Data

Preventive Maintenance Schedule.....	21
Preventive Maintenance Tips.....	21
Approved and Compatible Cleaners.....	22
How to Obtain Product Service.....	22

Specifications

Specifications.....	23
---------------------	----

Life Fitness® is a registered trademark.

Gym Wipes® is a registered trademark of the 2XL Corporation. PureGreen 24 is a trademark of Pure Green.

© Copyright 2021, Life Fitness, LLC. All Rights Reserved. Life Fitness, Hammer Strength, Cybex, ICG and SCIFIT are registered trademarks of Life Fitness, LLC and its affiliated companies and subsidiaries. Brunswick and related trademarks used under license from Brunswick Corporation. Disclaimer: Images and specifications are current as of the date of publication and are subject to change.













10601 W Belmont Ave, Franklin Park, IL 60131 • 847-288-3300

www.lifefitness.com • 1018091-0001 AA • 2021

1. Getting Started

Safety Instructions

Read all instructions before use.

-  **CAUTION:** Any changes or modifications to this equipment could void the product warranty.
 -  **CAUTION:** Risk of injury to persons – to avoid injury, use extreme caution when stepping onto or off of a moving belt. Read assembly instruction manual before using.
 -  **WARNING:** Health-related injuries may result from incorrect or excessive use of exercise equipment. Life Fitness Family of Brands STRONGLY recommends seeing a physician for a complete medical exam before undertaking an exercise program, particularly if the user has a family history of high blood pressure or heart disease, is over the age of 45, smokes, has high cholesterol, is obese, or has not exercised regularly in the past year. If, at any time while exercising, the user experiences faintness, dizziness, pain, or shortness of breath, he or she must stop immediately.
 -  **WARNING:** To reduce the risk of burns, fire, electric shock, or injury, it is imperative to connect each product to a properly grounded electrical outlet.
 -  **WARNING:** Heart rate monitoring systems may be inaccurate. Over exercising may result in serious injury or death. If you feel faint, stop exercising immediately.
 -  **WARNING:** Do not use for stretching and do not attach straps or other devices.
 -  **WARNING:** Keep batteries out of reach of children.
Some chest straps may contain a removable battery.
 - Swallowing may lead to serious injury in as little as 2 hours or death, due to chemical burns and potential perforation of the esophagus.
 - If you suspect your child has swallowed a battery, immediately call your local poison control for fast, expert advice.
 - Examine devices and make sure the battery compartment is correctly secured, e.g. that the screw or other mechanical fastener is tightened. Do not use if compartment is not secure.
 - Dispose of used button batteries immediately and safely. Flat batteries can still be dangerous.
 - Tell others about the risk associated with button batteries and how to keep their children safe.
 -  **WARNING:** Keep the area 6.5 ft. (2 m) by 3 ft. (0.9 m) behind the treadmill clear of any obstructions, including walls, furniture, and other equipment. Contact Customer Support Services for an optional longer power cord if necessary.
 -  **WARNING:** Be sure the emergency stop lanyard is clipped to the user and in proper position on the treadmill before beginning any workout.
 -  **WARNING:** The belt centering adjustment must be performed if the belt is not between the marks indicating the maximum allowed lateral positions. Refer to Treadmill Assembly Instructions.
 -  **WARNING:** This product can expose you to chemicals including Acrylonitrile, which is known to the State of California to cause cancer and birth defects or other reproductive harm. For more information go to <http://www.P65Warnings.ca.gov>
 -  **DANGER:** To reduce the risk of electrical shock or injury from moving parts, always unplug product before cleaning or attempting any maintenance activity.
- Never operate the product if it has a damaged power cord or electrical plug, or if it has been dropped, damaged, or even partially immersed in water. Contact Customer Support Services.
 - Position the product so that the power cord plug to the wall is accessible to the user. Make sure that the power cord is not knotted or twisted and that it is not trapped under any equipment or other objects.
 - If the electrical supply cord is damaged, it must be replaced by the manufacturer, an authorized service agent, or a similarly qualified person to avoid a hazard.
 - Always follow the console instructions for proper operation.
 - This appliance is not intended for use by persons (including children) with reduced physical, sensory, or mental capabilities, or lack of experience or knowledge unless they have supervision or been given instruction concerning the use of the appliance by a person responsible for their safety.
 - Do not use this product outdoors, near swimming pools or in areas of high humidity.
 - Never operate the product with the air openings blocked. Keep air openings free of lint, hair, or any other obstructing material.

- Never insert objects into any opening in these products. If an object should drop inside, turn off the power, unplug the power cord from the outlet, and carefully retrieve it. If the item cannot be reached, contact Customer Support Services.
- Never place liquids of any type directly on the unit, except in an accessory tray or holder. Containers with lids are recommended.
- Do not use these products in bare feet. Always wear shoes. Wear shoes with rubber or high-traction soles. Do not use shoes with heels, leather soles, cleats or spikes. Make sure no stones are embedded in the soles.
- Keep all loose clothing, shoelaces, and towels away from moving parts.
- Do not reach into, or underneath, the unit or tip it on its side during operation.
- This equipment is not intended for use by children. Keep children under the age of 14 away from the machine.
- Do not allow other people to interfere in any way with the user or equipment during a workout.
- Allow LCD consoles to "normalize" with respect to temperature for one hour before plugging the unit in and using.
- The product should never be left unattended when plugged in. Disconnect from the electrical outlet when not in use, and before putting on or taking off parts. To disconnect, turn power OFF at the ON/OFF switch, then remove plug from electrical outlet.
- Keep the power cord away from heated surfaces. Do not pull the equipment by the power cord or use the cord as a handle. Do not run the power cord on the floor under or along the side of the treadmill.
- Handrails may be held to enhance stability as needed, but are not for continuous use.
- Never mount or dismount the treadmill while the running belt is moving. Use the handrails whenever additional stability is required. In case of an emergency, such as tripping, grasp the handrails, and place the feet on the side platforms.
- Never walk or jog backwards on the treadmill.
- Do not use this product in areas where aerosol spray products are being used or where oxygen is being administered. Such substances create the danger of combustion and explosion.
- Use these products for their intended use as described in this manual. Do not use attachments that have not been recommended by the manufacturer.
- In conformity with the European Union Machinery Directive 2006/42/EC, this equipment unloaded runs at sound pressure levels below 70 dB (A) at the average operating speed of 12 km/hr (commercial units) and 8 km/hr (home units). Noise emission under load is higher than without load.
- Free standing equipment shall be installed on a stable and leveled surface.
- Read all warnings on each product prior to starting a workout.
- If warnings are missing or damaged, please contact Customer Support Services immediately for replacement warning labels. Warning labels are shipped with every product and should be installed before product is used. Life Fitness is not responsible for missing or damaged warning labels.

Set-Up

Read the entire manual before setting up the treadmill. Place the treadmill where it will be used before beginning the setup procedure.

Electrical Power Requirements

The treadmill requires a dedicated* line with isolated neutral according to the electrical configurations listed in the chart below.

Supply Voltage (VAC)	Frequency (Hz)	Rated Current (Amps)
100	50 / 60	18
120	50 / 60	18
200	50 / 60	9
220	50 / 60	9
230	50 / 60	9
240+	50 / 60	9

* One individual branch circuit for each treadmill per NEC article 210-21 (b) (1) and 210-22 (or other appropriate, country specific electrical compliance guidelines). The hot and neutral wires must each be routed independently (not looped or tied to other circuits).

NOTE: Do not modify the plug provided with this product. If the plug does not fit into an available electrical outlet, have a proper outlet installed by a qualified electrician.

Grounding Instructions

This product must be properly grounded. If the unit malfunctions or breaks down, proper grounding provides a path of least resistance for the electric current, which reduces the risk of shock to anyone touching or using the equipment. Each unit is equipped with an electrical cord, which includes an equipment grounding conductor and a grounding plug. The plug must be inserted into an outlet that has been properly installed and grounded in accordance with all local codes and ordinances.

 **WARNING:** A temporary adapter **MUST NOT BE USED** to connect this plug to a two-pole receptacle in North America. If a properly grounded, 20-amp outlet is not available, one must be installed by a qualified electrician. Models drawing 16 amps or more must be installed on a dedicated line. (Commercial Units Only).

 **DANGER:** A risk of electrical shock may result from improper connection of the equipment-grounding conductor. Check with a qualified electrician if in doubt as to proper grounding technique. **DO NOT** modify the plug provided with the product. If it will not fit an electrical outlet, have a proper outlet installed by a qualified electrician. Any modification to the electrical plug will result in a voided warranty.

How to Position and Stabilize the Treadmill

Follow all safety instructions. Move the treadmill to the location in which it will be used.

NOTE: See *How to Adjust and Tension the Striding Belt* to center the striding belt.

Safety Clearances

The following information is supplied as regional reference data regarding safety clearances around the exterior of the treadmill.

- **EU:** The European EN ISO 20957 Safety Standard requires a 6.5 ft. (2 m) minimum from the rear of the treadmill to any object or surface and at least as wide as the treadmill.
- **U.S. and other regions:** The ASTM International (ASTM) F2115 - 12 Standard recommends the minimum dimensions to be 1.64 ft. (0.5 m) on each side of the treadmill and 6.5 ft. (2 m) behind the rearward most portion of the usable moving surface or 6.5 ft. (2 m) behind the furthest rearward obstruction to emergency egress from the treadmill.

Free area

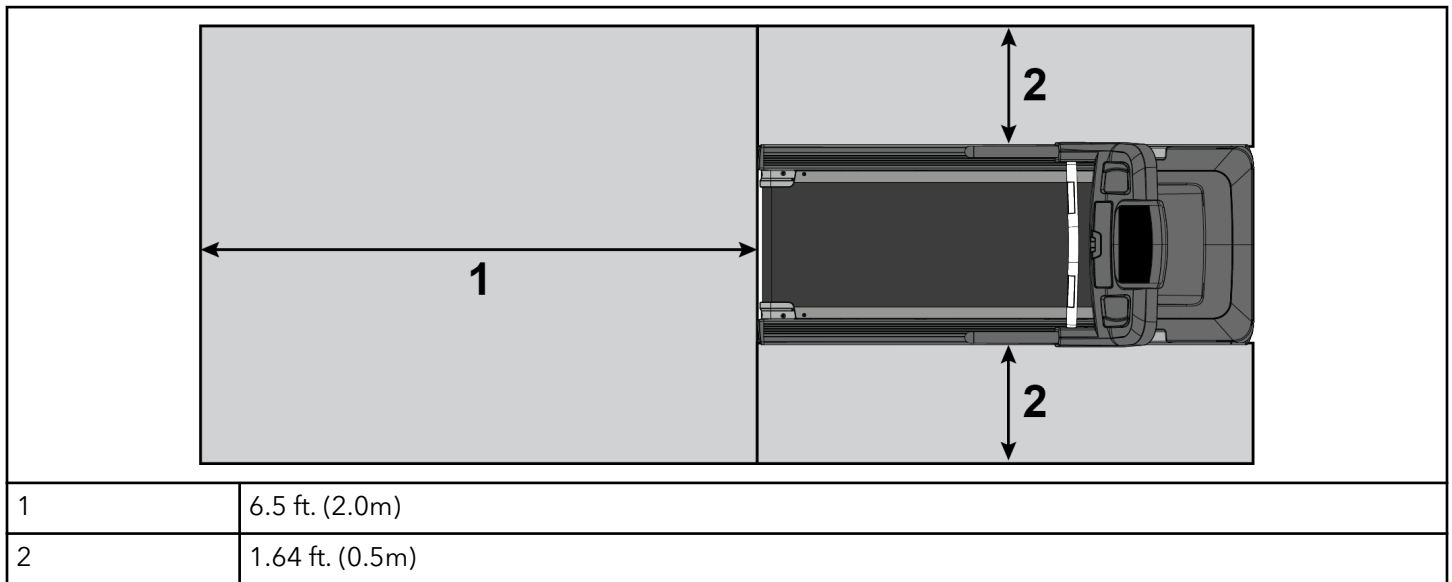

After placing the unit where it will be used, check its stability. If there is even a slight rocking motion or the unit is not stable, determine which stabilizing leg is not resting on the floor. To adjust, loosen the Jam Nut, and turn the Stabilizing Leg until the rocking motion ceases, and both stabilizing legs rest firmly on the floor. Re tighten the Jam Nut.

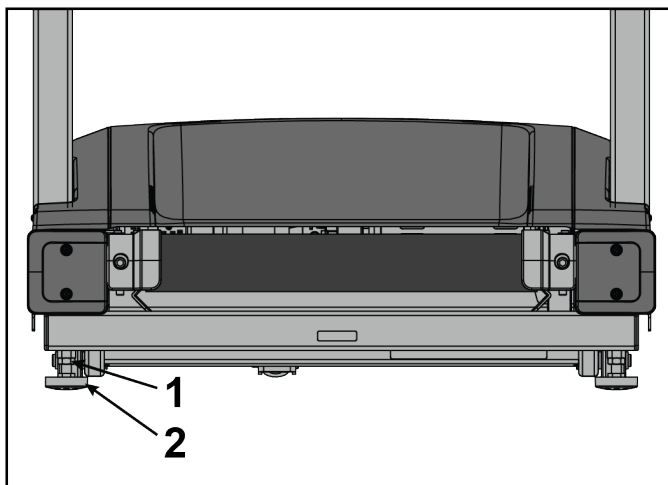

Item	Description	Qty.
1	Jam Nut	2
2	Stabilizing Leg	2

NOTE: Stabilize the treadmill each time the unit is relocated.

NOTE: It is extremely important that the stabilizing leg be correctly adjusted for proper operation. An unbalanced unit may cause striding belt misalignment. A bubble level is recommended to ensure proper leveling.

Power Switch

Located on the front panel at the base of the treadmill, the ON/OFF switch has two positions: "1" (one) for ON and "0" (zero) for OFF.

Power Cord Routing



WARNING: Make sure the power cord is unplugged before attempting to route it around or through the treadmill.

Connect the power cord to the power receptacle in the front of the treadmill. The power cord can be run to the user-front left or right sides depending on installation / site needs.

NOTE: To accommodate treadmill incline, at least 2 ft. (24") of power cord is required between the outlet and the last power cord clip for outlets in front of the treadmill.



WARNING: Keep the area 6.5 ft. (2 m) by 3 ft. (0.9 m) behind the treadmill clear of any obstructions, including walls, furniture, and other equipment. Contact Customer Support Services for an optional longer power cord if necessary.



DANGER: Ensure that the power cord does not contact the striding belt or get pinched between the frame, lift arm or under the wheels; failure to follow this warning may result in serious injury.

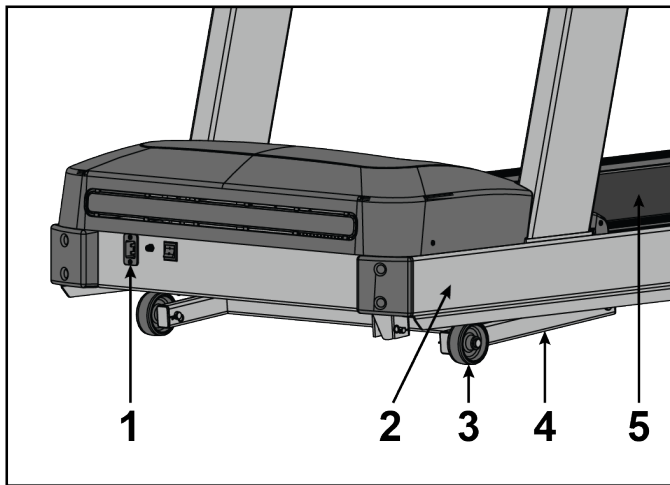

Item	Description
1	Power Receptacle
2	Frame
3	Wheel
4	Lift Arm
5	Striding Belt

Immobilization Method

The purpose of immobilizing the treadmill is to prevent unauthorized use. The system causes immobilization of the treadmill when a pre-defined hard key sequence has been activated.

1. Set the display to read **SELECT WORKOUT**.

NOTE: Press the **CLEAR** key twice if not already there

2. Hold down the **SPEED DOWN** key and press the **PAUSE** key.

The treadmill now displays **IMMOBILIZED**. In this state, the treadmill cannot be operated. The belt and incline motors are disabled. The treadmill will remain in this state across resets, power cycles, etc. To restore normal operation, repeat the same key sequence; hold down the **SPEED DOWN** key, and press the **PAUSE** key. The treadmill will display **SELECT WORKOUT** again.

2. Product Overview

Product Features

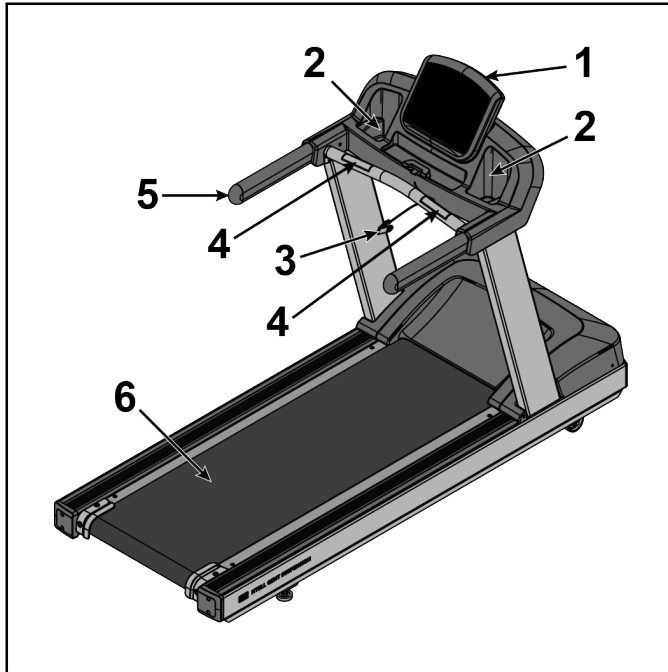

Item	Description
1	Console
2	Cup Holders
3	Emergency Stop Lanyard
4	Contact Heart Rate Sensors
5	Handrails
6	Striding Belt

Mounting and Dismounting the Treadmill

Use the handrails to enhance stability when mounting or dismounting a treadmill. Never mount or dismount the treadmill while the running belt is moving. Use the STOP button on the console to end a workout and stop the running belt. Use the Emergency Stop System to stop the belt immediately.

User Position

The width of the moving walking/running surface is 20 in. (51 cm). Users must keep their feet within this width while in motion. If standing on the stationary side rails, a user should ensure that his/her feet are completely on the non-moving portion. Never step partially on the moving surface and partially on the non-moving surface simultaneously.

- Users can adjust their fore-aft position on the moving belt as desired for reach to the console and handles, clearance for arm swing and attachment of the safety stop pull cord. Do not step on the rear roller.
- It is recommended that the user run within the length of the side handrails to allow usage of the side arms to dismount the belt if needed.

Using and Testing the Emergency Stop System

The treadmill is equipped with an Emergency Stop System. The system consists of a rectangular stop magnet (located on the upper bridge plastic) attached to a safety stop pull cord.

Before starting a workout, attach the lanyard on the safety stop pull cord to an item of the user's clothing. During a workout, pull the cord to remove the magnet from the bridge. This will immediately stop the treadmill belt.

NOTE: Test the safety stop pull cord by attaching the lanyard to a user's item of clothing during operation of the treadmill. While the treadmill is on and the console display is active, remove the safety stop pull cord / magnet from the bridge. A message will be displayed on the console similar to "Replace the emergency stop switch". With the safety stop pull cord removed no keys shall function on the treadmill. Place the safety stop pull cord back in place. The treadmill will reset and will be ready for operation.

3. Assembly

Component and Hardware List

Components

Item	Description	Qty
1	Left Upright	1
2	Right Upright	1
3	Ergo™ Front Crossbar	1
4	Upper Dashboard Tray	1
5	Lower Dashboard Tray	1
6	Console	1
7	End Cap Front	2
8	End Cap Rear	2
9	Bridge	1
10	Ergo™ Bar Backing Plate	2
11	Cable Tie	2

Hardware

Item	Description	Qty
1	Bolt, 3/8 x 5" Hex Head	8
2	Washer, 3/8" Flat	8
3	Lock Nut, 3/8"	6
4	Bolt, M8 x 20mm Hex Head	8
5	Washer, M8	12
6	Lock Nut, M8	8
7	Plastic Grommet	2
8	Screw, M4.2 x 19mm Phillips Head	14
9	Screw, M5 x 25mm Phillips Head	4
10	Screw, #10 x 0.5" Phillips Head (silver)	2
11	Screw, #10 x 0.5" Phillips Head (black)	2

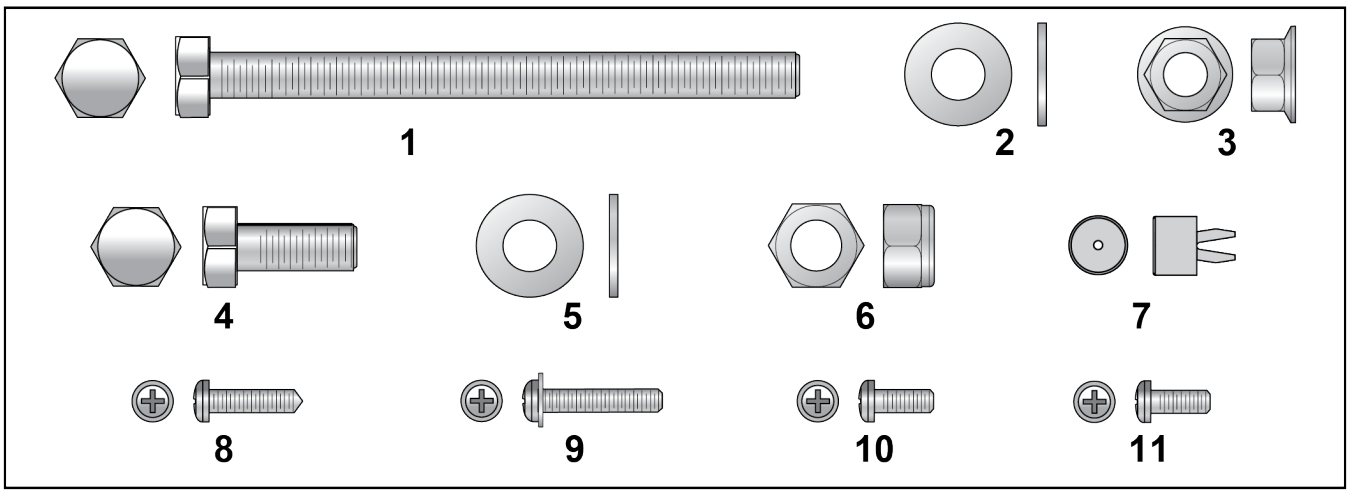

Tools Required

- Phillips screwdriver
- 9/16" Wrench (2)
- 9/16" Socket 3/8" Drive
- 13 mm Socket
- 13 mm Wrench
- 3" Extension 3/8" Drive
- 3/8" Drive ratchet

Remove Motor Cover

1. Remove screws securing motor cover to base assembly using a Phillips screwdriver.

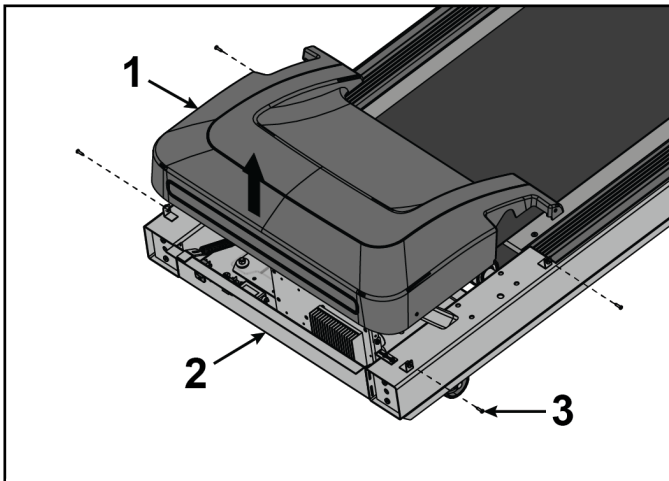

Item	Description	Qty
1	Motor Cover	1
2	Base Assembly	1
3	Screw, M4.2 x 19mm Phillips Head	4

2. Remove motor cover.

Install Uprights

1. Place uprights on base assembly.
2. Install one bolt, washer, and lock nut to left and right upright and base assembly using a 9/16" socket and wrench.

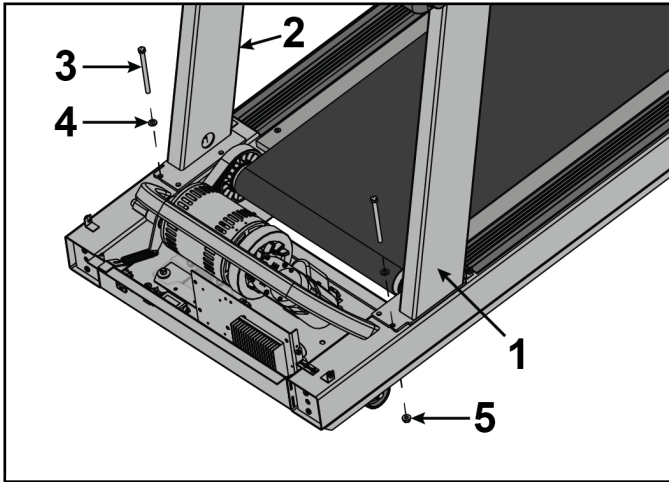

Item	Description	Qty
1	Left Upright	1
2	Right Upright	1
3	Bolt, 3/8 x 5" Hex Head	2
4	Washer, 3/8" Flat	2
5	Lock Nut, 3/8"	2

NOTE: Leave a spacing of 5-12mm between washer and upright.

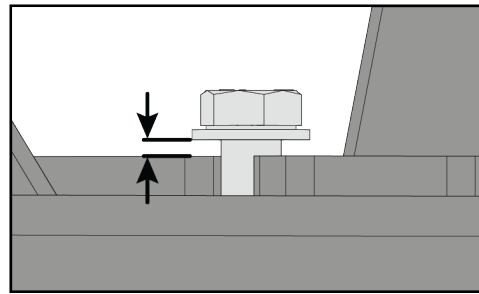

3. Align uprights with holes in base assembly.
4. Install bolts, washers, and lock nuts securing uprights to base assembly using a 9/16" socket and wrench.

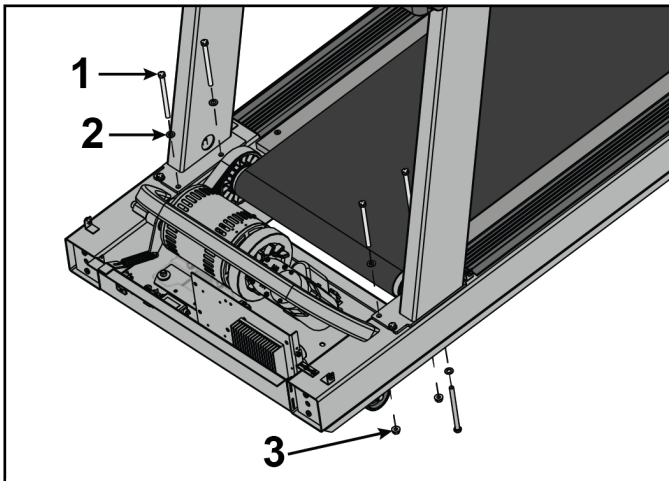

Item	Description	Qty
1	Bolt, 3/8 x 5" Hex Head	6
2	Washer, 3/8" Flat	6
3	Lock Nut, 3/8"	4

Install Front Crossbar

1. Route cable from front crossbar into left upright.

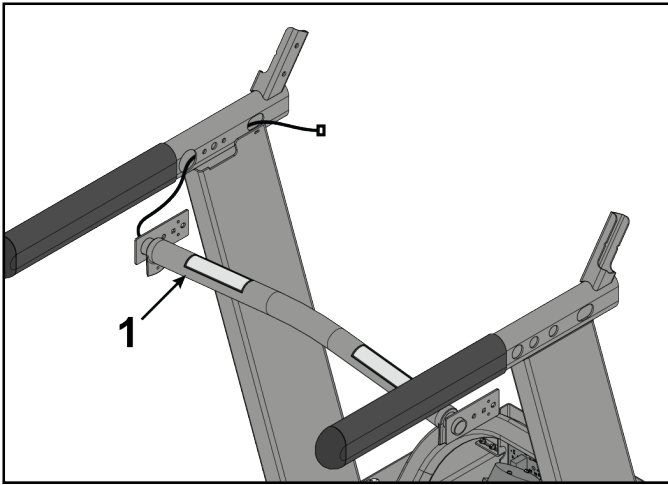

Item	Description	Qty
1	Ergo™ Front Crossbar	1

2. Install bolts, washers, and lock nuts securing front crossbar to uprights using a 13mm socket and wrench.

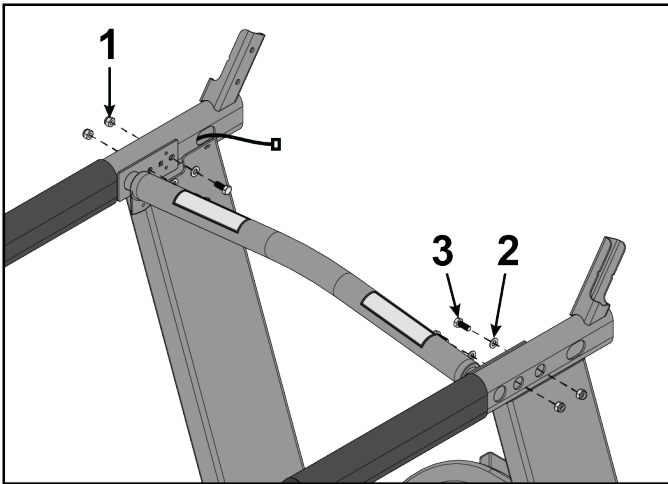

Item	Description	Qty
1	Lock Nut, M8	4
2	Washer, M8	4
3	Bolt, M8 x 20mm Hex Head	4

Install Bridge

1. Install a bolt, washers, and lock nut to each upright using a 13mm socket and wrench.

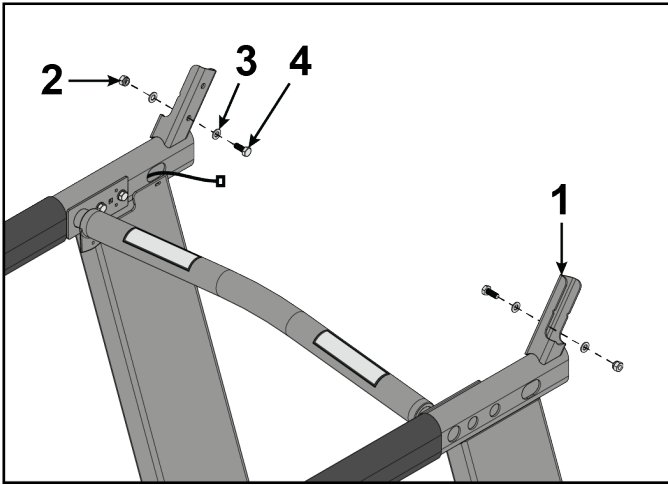

Item	Description	Qty
1	Upright	2
2	Lock Nut, M8	2
3	Washer, M8	4
4	Bolt, M8 x 20mm Hex Head	2

NOTE: Leave a spacing of 5-12mm between washer and upright.

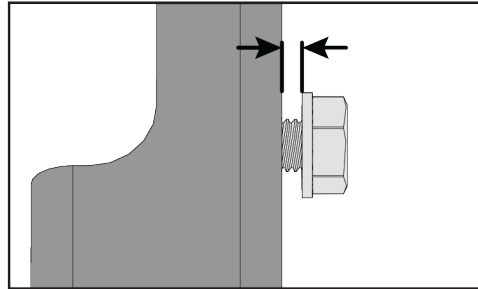

2. Slide bridge down uprights.

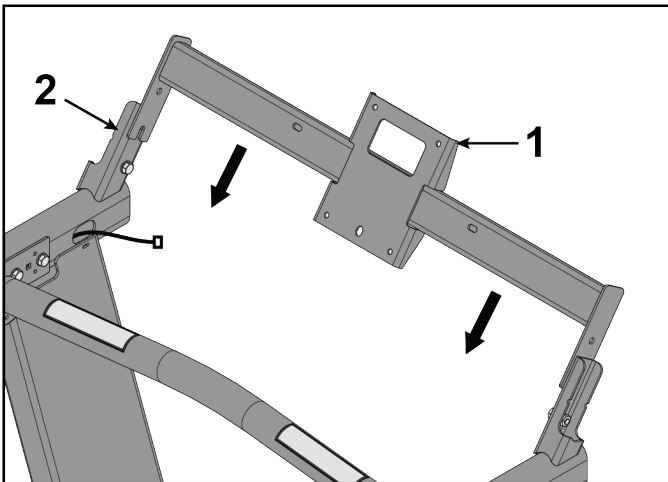

Item	Description	Qty
1	Bridge	1
2	Upright	2

3. Install bolts, washers, and lock nuts securing the bridge to uprights using a 13mm socket and wrench.

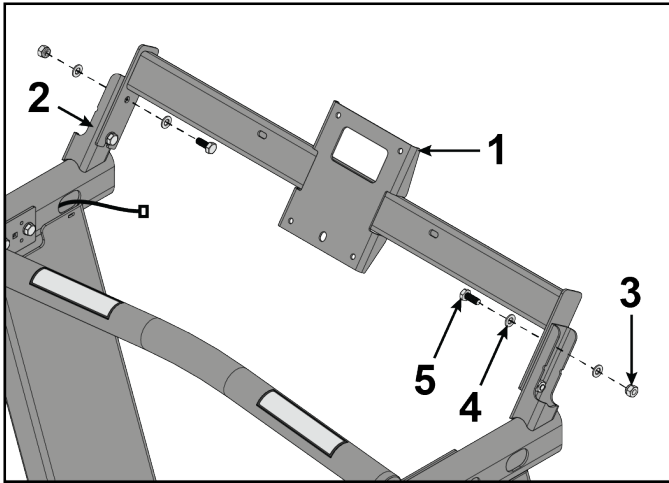

Item	Description	Qty
1	Bridge	1
2	Upright	2
3	Lock Nut, M8	2
4	Washer, M8	4
5	Bolt, M8 x 20mm Hex Head	2

Tighten Upper Hardware

Tighten hardware 100%.

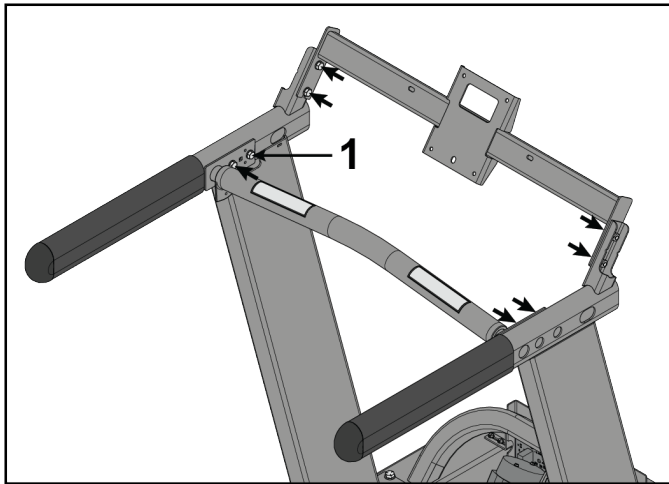

Item	Description	Qty
1	Bolt, M8 x 20mm Hex Head	8

Tighten Lower Hardware

Tighten hardware 100%.

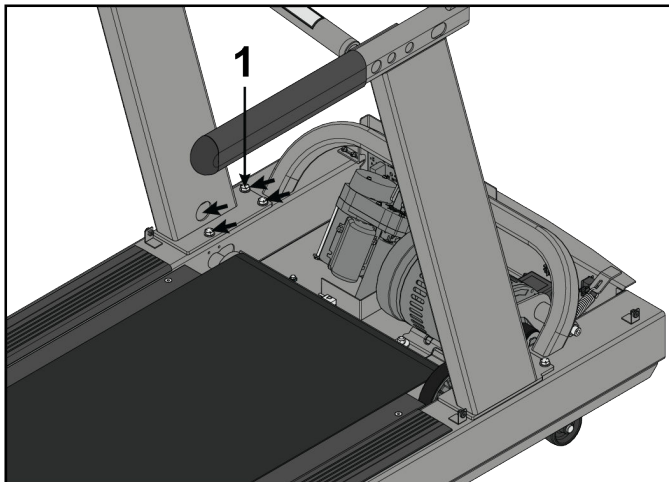

Item	Description	Qty
1	Bolt, 3/8 x 5" Hex Head	8

Install Console Cables and Grommets

NOTE: TV cables (Coax and power) are included in every treadmill with or without TV option. They must be routed up through left upright and stored in dashboard.

1. Route TV cables (Coax and power) up through left upright and into dashboard area.

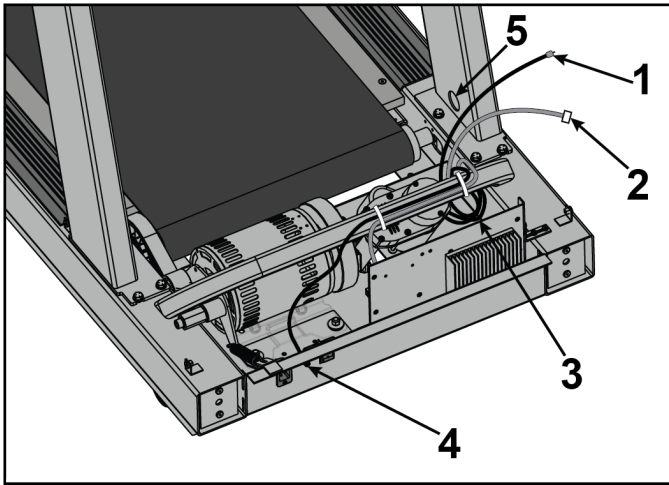

Item	Description	Qty
1	Coax Cable	1
2	Power Cable	1
3	TV Cables are Coiled and Stored Here	1
4	External Coax Cable Connection	1
5	Access Hole for Cables	1

2. Route console cable up through left upright.
3. Install plastic grommets to front crossbar.

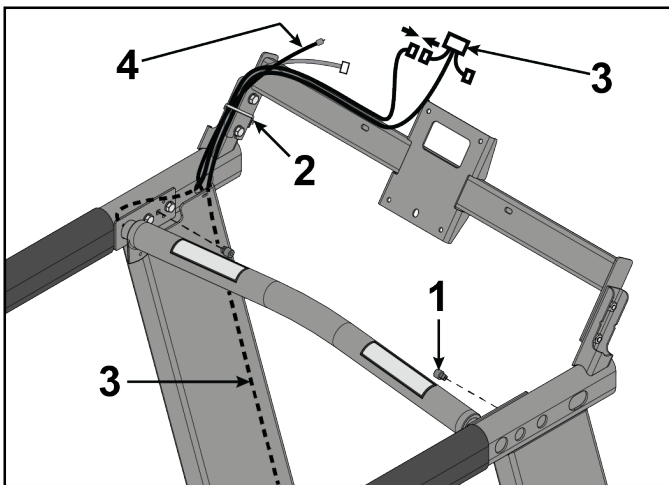

Item	Description	Qty
1	Plastic Grommet	2
2	Cable Tie	2
3	Console Cable	1
4	TV Cables (Coax and Power)	1

NOTE: For international units, install the ferrite approximately 7 inches from the center of the bridge. Route console cable through ferrite and secure with cable tie.

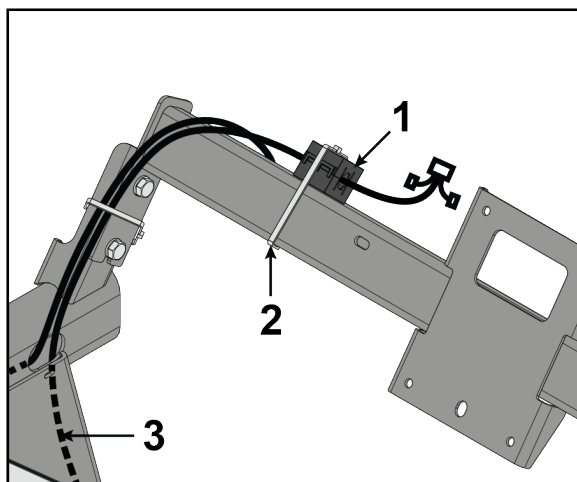

Item	Description	Qty
1	Ferrite	1
2	Cable Tie	1
3	Console Cable	1

4. Secure cables from front crossbar and left upright to the bridge using cable ties.

Install Upper Dashboard Tray

1. Install screws securing bar backing plate to front crossbar using a Phillips screwdriver.

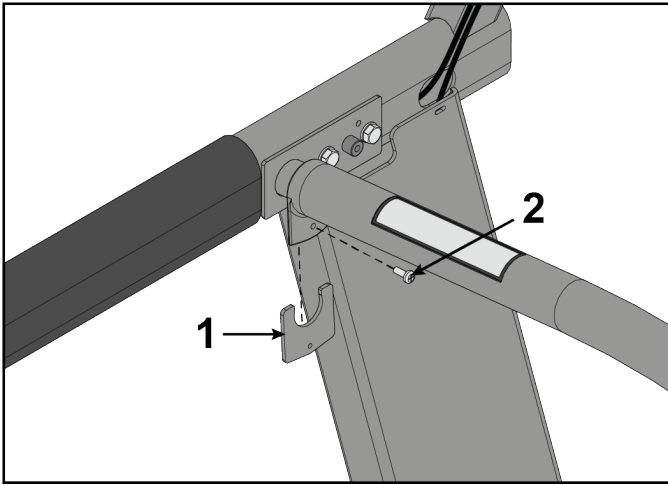

Item	Description	Qty
1	Ergo™ Bar Backing Plate	2
2	Screw, #10 x 0.5" Phillips Head (black)	2

2. Install screws securing upper dashboard tray to front crossbar using a Phillips screwdriver.

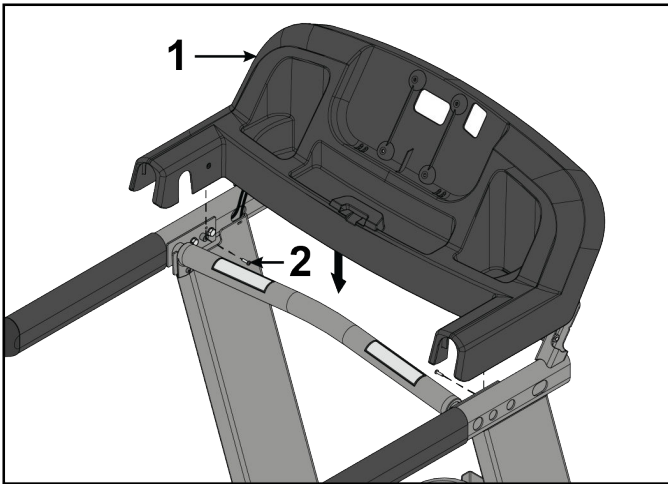

Item	Description	Qty
1	Upper Dashboard Tray	1
2	Screw, M4.2 x 19mm Phillips Head	2

NOTE: Be careful not to over tighten screws. Over tightening can damage the plastic.

Install Console

1. Install screws securing console to upper dashboard tray using a Phillips screwdriver.

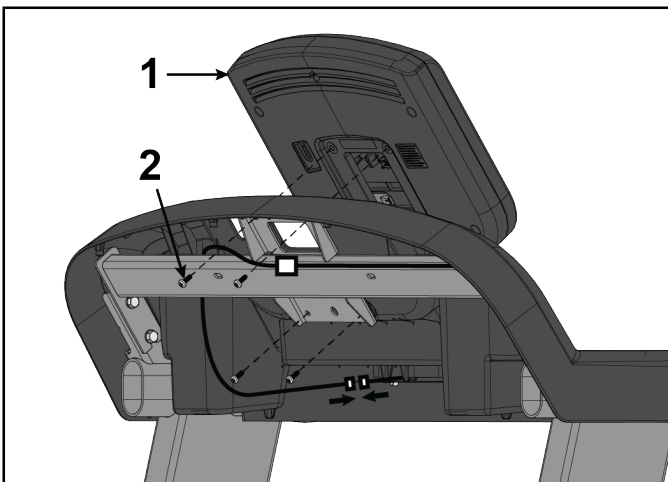

Item	Description	Qty
1	Console	1
2	Screw, M5 x 25mm Phillips Head	4

2. Connect cables.

Console Connections

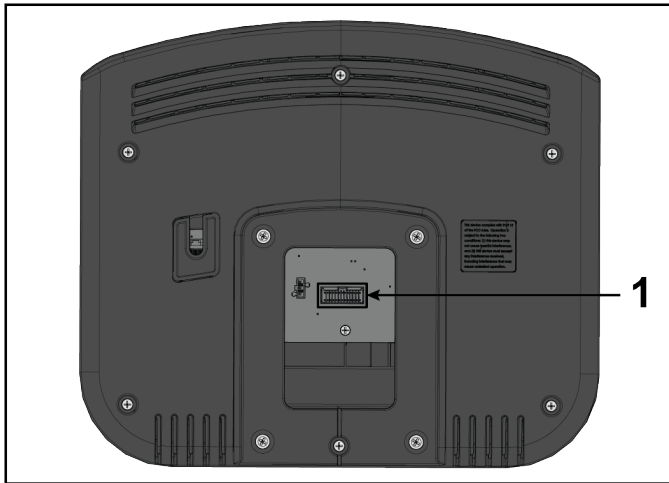

Item	Description	Qty.
1	Display Connection	1

Install Lower Dashboard Tray

Install screws securing lower dashboard tray to upper dashboard tray using a Phillips screwdriver.

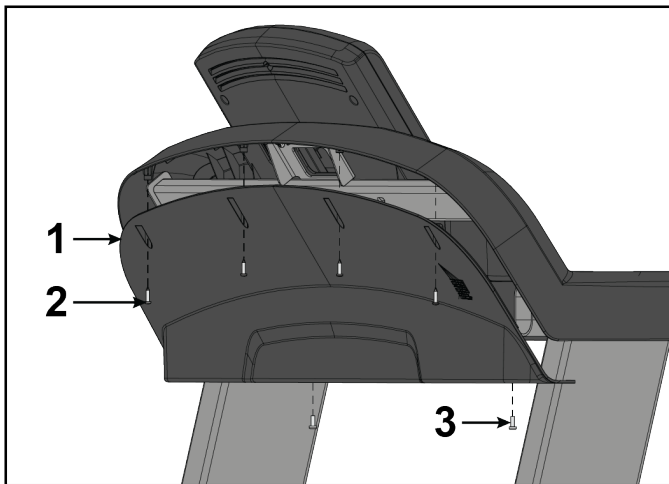

Item	Description	Qty
1	Lower Dashboard Tray	1
2	Screw, M4.2 x 19mm Phillips Head	4
3	Screw, #10 x 0.5" Phillips Head (silver)	2

Install Rear End Caps

Install screws securing rear end caps to base assembly using a Phillips screwdriver.

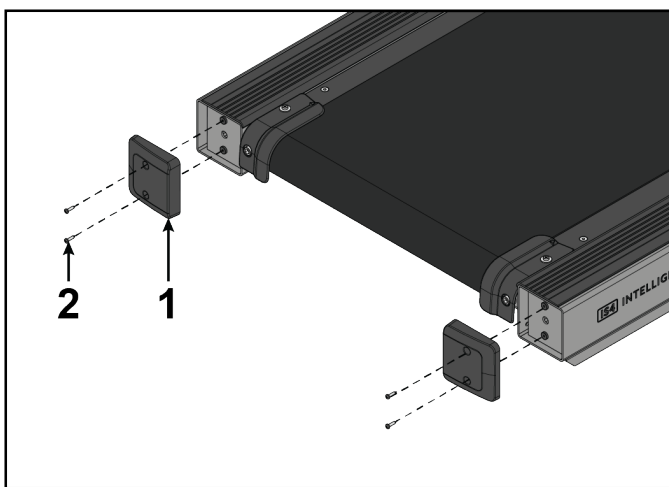

Item	Description	Qty
1	Rear End Cap	2
2	Screw, M4.2 x 19mm Phillips Head	4

Install Motor Cover

Install screws securing motor cover to base assembly using a Phillips screwdriver.

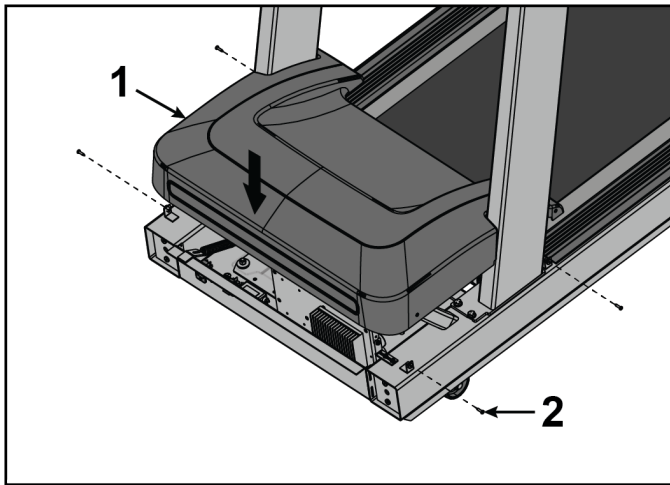

Item	Description	Qty
1	Motor Cover	1
2	Screw, M4.2 x 19mm Phillips Head	4

Install Front End Caps

Install screws securing front end caps to base assembly using a Phillips screwdriver.

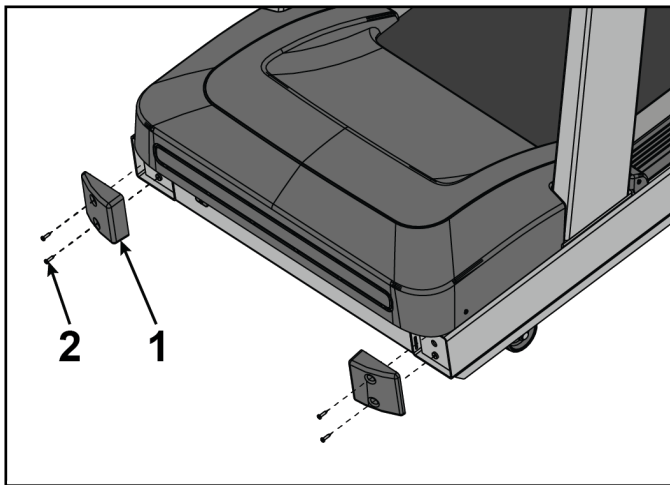

Item	Description	Qty
1	Front End Cap	2
2	Screw, M4.2 x 19mm Phillips Head	4

Install Power Cord

1. Insert power cord into power receptacle in front of treadmill.

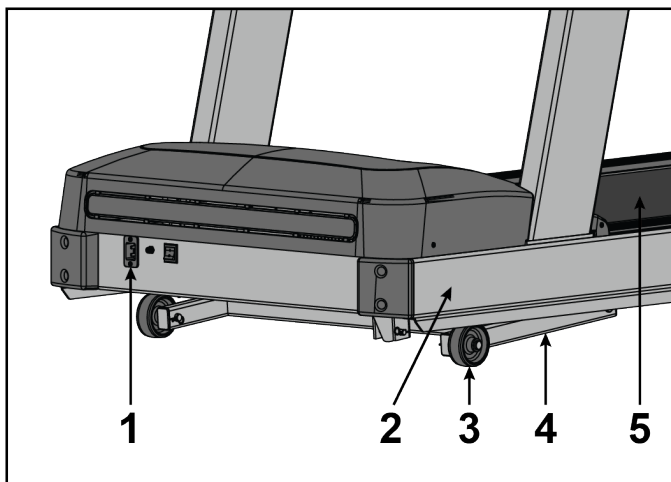

Item	Description
1	Power Receptacle
2	Frame
3	Wheel
4	Lift Arm
5	Striding Belt

2. Route power cord on left or right side of treadmill depending on installation / site needs.



CAUTION: Make sure that there is 6.5 ft. (2 m) of clearance behind the treadmill. Contact Life Fitness Customer Support Services for an optional longer power cord if necessary.



CAUTION: Insure that power cord does not contact striding belt or get pinched between frame, lift frame, or wheel. Failure to follow this warning may result in serious injury.

4. Service and Technical Data

Preventive Maintenance Schedule

Item	Weekly	Monthly	Biannually
Console Overlays	Clean		Inspect
Bottle Holders / Accessory Trays	Clean	Inspect	
Console Mounting Bolts			Inspect
Hardware			Inspect
Frame	Clean		Inspect
Plastic Covers	Clean	Inspect	
Lifepulse Sensors	Clean / Inspect		
Striding Belt Centered	Inspect		
Emergency Stop Magnet	Clean / Inspect		
Motor Cover	Clean	Vacuum / Clean	
Motor Electronic Compartment			Inspect
Drive Belt			Inspect
Leg Levelers		Inspect / Adjust	
Front and Rear Rollers			Inspect
Side Step Area	Clean	Inspect	
Side Hand Rails	Clean		Inspect
Ergo™ Front Handlebar	Clean		Inspect

Preventive Maintenance Tips

NOTE: Safety of the equipment can be maintained only if the equipment is examined regularly for damage or wear. Keep the equipment out of use until defective parts are repaired or replaced. Pay special attention to parts that are subject to wear, as outlined below.

The following preventive maintenance tips will keep the product operating at peak performance:

- Locate the product in a cool, dry place.
- Clean the display console and all exterior surfaces with an approved or compatible cleaner (see Approved and Compatible Cleaners) and a microfiber cloth.
- Long fingernails may damage or scratch the surface of the console; use the pad of the finger to press the selection buttons on the console.
- Check operation of the emergency stop system once a week.
- Inspect and vacuum the area directly surrounding and under the unit regularly.
- Vacuum around the striding belt regularly to keep debris from accumulating.
- Inspect exterior parts regularly for wear, particularly the striding belt, deck and line cord.
- Check to make sure the unit is properly leveled.
- Check the position (centering) of the striding belt.

NOTE: Normal belt operating position is for the belt to be located within the belt travel indicators on the rear roller guards. Refer to *Tracking (Centering) A Striding Belt* or contact Customer Support Services for proper alignment instructions.

Approved and Compatible Cleaners

Two preferred cleaners have been approved by reliability experts: PureGreen 24 and Gym Wipes. Both cleaners will safely and effectively remove dirt, grime and sweat from equipment. PureGreen 24 and the Antibacterial Force formula of Gym Wipes are both disinfectants that are effective against MRSA and H1N1.

PureGreen 24 is available in a spray which is convenient for gym staff to use. Apply the spray to a microfiber cloth and wipe down the equipment. Use PureGreen 24 on the equipment for at least 2 minutes for general disinfection purposes and at least 10 minutes for fungus and viral control.

Gym Wipes are large, durable pre-moistened wipes to use on the equipment before and after workouts. Use Gym Wipes on the equipment for at least 2 minutes for general disinfection purposes.

Contact Customer Support Services to order these cleaners (1-800-351-3737 or email: customersupport@lifefitness.com).

Mild soap and water or a mild non-abrasive household cleaner can also be used to clean the display and all exterior surfaces. Use a soft microfiber cloth only. Apply the cleaner to the microfiber cloth before cleaning. DO NOT use ammonia or acid based cleaners. DO NOT use abrasive cleaners. DO NOT use paper towels. DO NOT apply cleaners directly to the equipment surfaces.

How to Obtain Product Service

1. Verify the symptom and review the operating instructions. The problem may be unfamiliarity with the product and its features and workouts.
2. Locate and write down the serial number of the unit which is located on the back of the unit near the toe guard.
3. Contact Customer Support at <http://www.lifefitness.com>.

5. Specifications

Specifications

Designed Use	Heavy / Commercial, EN ISO 20957 Class S
Maximum User Weight	400 lbs. / 181 kg
Speed Range	0.5 - 12.0 MPH (0.8 - 19.3 KPH) in 0.1 increments
Incline Range	0% - 15%
Drive Train	AC motor with variable speed controller
Motor Type	AC Induction
Motor Size	4.0 HP continuous duty, 8.0 HP peak
Power Requirements	See <i>Electrical Requirements</i> for requirements outside the U.S.
	Dedicated 120 volt, 20 amp (U.S)
Rollers	2.75" (70 cm) diameter, precision-crowned, front and back
Striding Belt	60" Length x 20" Width (152 cm Length x 51 cm Width) (pre-lubricated)
Belt Type	2-ply, polyester weave, anti-slip PU top cover, antistatic
Deck Type	3/4" Medium Density Fiberboard (MDF), reversible
Shock Absorption System	Flex Deck
Side Handrail	16" (41 cm) flared
Stop Systems	Red magnetic lanyard emergency stop system
Heart Rate Monitoring Systems	Patented Lifepulse™ digital contact heart rate
CATV (1)	F-type connector

Activate Console

	Physical Dimensions	Shipped Dimensions
Length	14 in. / 35.56 cm	17 in. / 43.18 cm
Width	12 in. / 30.48 cm	15.5 in. / 39.37 cm
Height	3.2 in. / 8.13 cm	5.5 in. / 13.97 cm
Weight	2.4 lbs. / 1.09 kg	5 lbs. / 2.27 kg

Treadmill Base

	Physical Dimensions	Shipped Dimensions
Length	79.86 in. / 202.84 cm	85 in. / 216 cm
Width	32.1 in. / 81.53 cm	40 in. / 101.6 cm
Height	57 in. / 145 cm	25 in. / 63.5 cm
Weight	325 lbs. / 147.42 kg	346 lbs. / 157 kg

