

Signature Accessory Storage Rack (SAR)

Owner's Manual

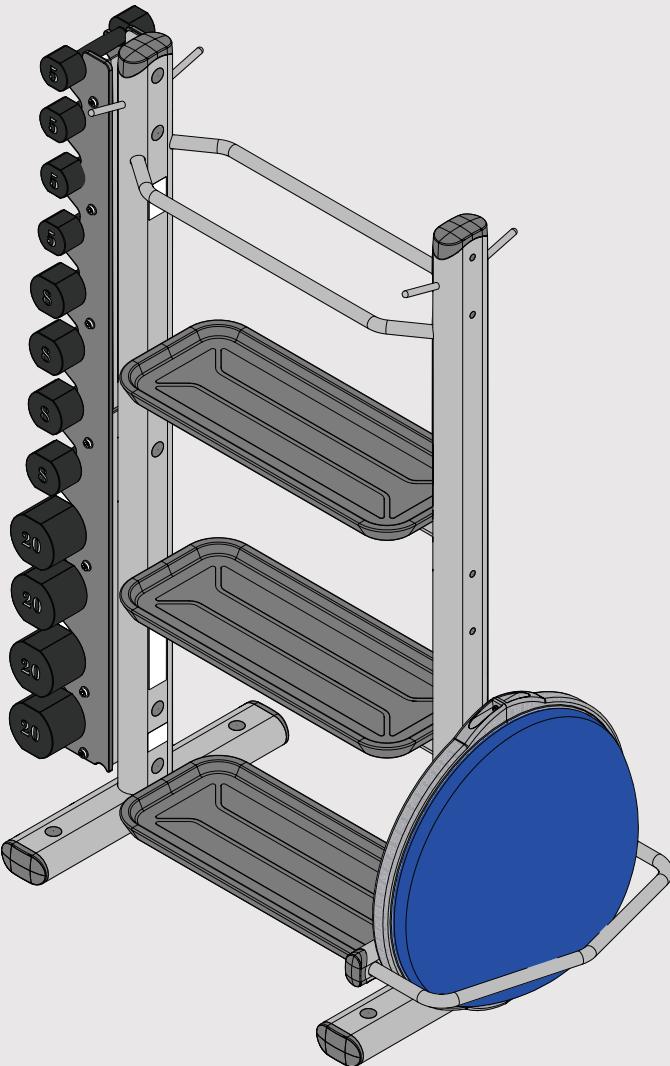

CORPORATE HEADQUARTERS

Columbia Centre III, 9525 West Bryn Mawr Avenue, Rosemont, Illinois 60018 • U.S.A.

847.288.3300 • FAX: 847.288.3703

Service phone number: 800.351.3737 (toll-free within U.S.A., Canada)

Global Website: www.lifefitness.com

INTERNATIONAL OFFICES

AMERICAS

North America Life Fitness, Inc.

Columbia Centre III
9525 West Bryn Mawr Avenue
Rosemont, IL 60018 U.S.A
Telephone: (847) 288 3300
Fax: (847) 288 3703
Service Email:
customersupport@lifefitness.com
Service Website: www.lifefitness.com/parts
Sales/Marketing Email:
commercialsales@lifefitness.com
Operating Hours: 7:00 am-6:00 pm (CST)

Brazil Life Fitness Brasil

Av. Cidade Jardim, 900
Jd. Paulistano
São Paulo, SP 01454-000
BRAZIL
SAC: 0800 773 8282
Telephone: +55 (11) 3095 5200
Fax: +55 (11) 3095 5201
Service Email: suporte@lifefitness.com.br
Sales/Marketing Email:
lifefitness@lifefitness.com.br
Service Operating Hours:
9:00 - 17:00 (BRT) (Monday-Friday)
Store Operating Hours:
9:00 -20:00 (BRT) (Monday-Friday)
10:00 - 16:00 (BRT) (Saturday)

Latin America & Caribbean* Life Fitness Inc.

Columbia Centre III
9525 West Bryn Mawr Avenue
Rosemont, IL 60018 U.S.A
Telephone: (847) 288 3300
Fax: (847) 288 3703
Service Email:
customersupport@lifefitness.com
Sales/Marketing Email:
commercialsales@lifefitness.com
Operating Hours: 7:00am-6:00pm (CST)

EUROPE, MIDDLE EAST, & AFRICA

(EMEA)

Netherlands & Luxemburg Life Fitness Atlantic BV

Bijdorpplein 25-31
2992 LB Barendrecht
THE NETHERLANDS
Telephone: (+31) 180 646 666
Fax: (+31) 180 646 699
Service Email:
service.benelux@lifefitness.com
Sales/Marketing Email:
marketing.benelux@lifefitness.com
Operating Hours: 9.00h-17.00h (CET)

United Kingdom & Ireland Life Fitness UK LTD

Queen Adelaide
Ely, Cambs, CB7 4UB
Telephone: General Office (+44)
1353.666017
Customer Support (+44) 1353.665507
Fax: (+44) 1353.666018
Service Email: uk.support@lifefitness.com
Sales/Marketing Email: life@lifefitness.com
Operating Hours:
General Office: 9.00am - 5.00pm (GMT)
Customer Support: 8.30am - 5.00pm (GMT)

Germany & Switzerland Life Fitness Europe GMBH

Siemensstraße 3
85716 Unterschleißheim
GERMANY
Telephone: (+49) 89.31 77 51.0 (Germany)
(+41) 0848 000 901 (Switzerland)
Fax: (+49) 89.31 77 51.99 (Germany)
(+41) 043 818 07 20 (Switzerland)
Service Email:
kundendienst@lifefitness.com
Sales/Marketing Email:
kundenberatung@lifefitness.com
Operating Hours: 08.30 -16.30h (CET)

Austria Life Fitness Austria

Vertriebs G.m.b.H.
Dückerstraße 7-9/3/36
1220 Vienna
AUSTRIA
Telephone: (+43) 1.61.57.198
Fax: (+43) 1.61.57.198.20
Service Email: kundendienst@lifefitness.com
Marketing/Sales Email:
kundenberatung@lifefitness.com
Operating Hours: 08:30-16.30.h (MEZ)

Spain Life Fitness IBERIA

C/Frederic Mompou 5,1ªª
08960 Sant Just Desvern Barcelona
SPAIN
Telephone: (+34) 93.672.4660
Fax: (+34) 93.672.4670
Service Email: servicio.tecnico@lifefitness.com
Sales/Marketing Email:
info.iberia@lifefitness.com
Operating Hours:
9.00h-18.00h (Monday-Thursday)
8.30h-15.00h (Friday)

Belgium Life Fitness Benelux NV

Parc Industriel de Petit-Rechain
4800 Verviers
BELGIUM
Telephone: (+32) 87 300 942
Fax: (+32) 87 300 943
Service Email:
service.benelux@lifefitness.com
Sales/Marketing Email:
marketing.benelux@lifefitness.com
Operating Hours: 9.00h -17.00h (CET)

All Other EMEA Countries & Distributor Business C-EMEA*

Bijdorpplein 25-31
2992 LB Barendrecht
THE NETHERLANDS
Telephone: (+31) 180 646 644
Fax: (+31) 180 646 699
Service Email:
service.db.cemea@lifefitness.com
Sales/Marketing Email:
marketing.db.cemea@lifefitness.com
Operating Hours: 9.00h-17.00h (CET)

ASIA PACIFIC (AP)

Japan Life Fitness Japan

Japan Nippon Brunswick Bldg., #8F
5-27-7 Sendagaya
Shibuya-Ku, Tokyo
Japan 151-0051
Telephone: (+81) 3.3359.4309
Fax: (+81) 3.3359.4307
Service Email: service@lifefitnessjapan.com
Sales/Marketing Email:
sales@lifefitnessjapan.com
Operating Hours: 9.00h-17.00h (JAPAN)

Hong Kong Life Fitness Asia Pacific LTD

32/F, Global Trade Square
21 Wong Chuk Hang Road
HONG KONG
Telephone: (+852) 2575.6262
Fax: (+852) 2575.6894
Service Email:
HongKongEnquiry@lifefitness.com
Sales/Marketing Email:
Marketing.HK.Asia@lifefitness.com
Operating Hours: 9.00h-17.00h
Service Operating Hours: 9.00h-18.00h

All Other Asia Pacific countries & distributor business Asia Pacific* Life Fitness Asia Pacific LTD

32/F, Global Trade Square
21 Wong Chuk Hang Road
HONG KONG
Telephone: (+852) 2575.6262
Fax: (+852) 2575.6894
Service Email:
HongKongEnquiry@lifefitness.com
Sales/Marketing Email:
Marketing.HK.Asia@lifefitness.com
Operating Hours: 9.00h-17.00h
Service Operating Hours: 9.00h-18.00h

* Also check www.lifefitness.com for local representation or distributor/dealer

TABLE OF CONTENTS

DESCRIPTION	PAGE
SAFETY INFORMATION	3
CONTACT INFORMATION	4
WARRANTY	4
SPECIFICATIONS	6
WARNING LABELS	7
STORAGE TYPES	7
INSTALLATION INSTRUCTIONS	
HARDWARE	8
TOOLS REQUIRED	8
BASE UNIT	8
MAT	9
MAT & ROLLERS	11
VERTICAL BOSU	12
2-STABILITY BALLS	13
3-STABILITY BALLS	14
BEAUTY BELLS	15
BEAUTY BELLS & ROLLERS	16
BOLT TO FLOOR GUIDELINES	18

SAFETY INFORMATION

It is the sole responsibility of the purchaser of LIFE FITNESS products to read the owner's manual and warning labels and instruct all individuals, whether they are the end user or supervising personnel, on proper usage of the equipment.

UNDERSTANDING EACH AND EVERY WARNING TO THE FULLEST IS IMPORTANT. IF ANY OF THESE WARNINGS ARE UNCLEAR, CONTACT LIFE FITNESS CUSTOMER SERVICE IMMEDIATELY AT 1-800-735-3867.

This equipment is categorized as class S per ISO 20957-1. As such this equipment is only intended for commercial, institutional and/or studio facilities. It is not intended for home use. Contact LIFE FITNESS with any questions regarding this classification.

It is recommended that all users of LIFE FITNESS exercise equipment be informed of the following information prior to use.

ACCESS CONTROL

LIFE FITNESS recommends that all commercial fitness equipment be used in a supervised area. It is recommended that the equipment be located in an access controlled area. Control is the responsibility of the facility owner.

INSTALLATION

Manufacturer **recommends** that this training equipment be secured to the floor by a licensed contractor. Refer to the Bolt to Floor Guidelines in this manual for assembly instructions on proper attaching operation and minimum pullout force of the anchors.

Contact LIFE FITNESS with any installation questions.

PROPER USAGE

Do not use any equipment in any way other than designed or intended by the manufacturer. It is imperative that LIFE FITNESS equipment is used properly to avoid injury.

Injuries may result if exercising improperly or excessively. It is recommended that all individuals consult a physician prior to commencing an exercise program. If at any time during exercise you feel faint, dizzy or experience pain, STOP EXERCISING and consult your physician.

Body weight strap training devices can only be attached to High Wear Gray areas.

INSPECTION

DO NOT use or permit use of any equipment that is damaged and/or has worn or broken parts. For all LIFE FITNESS equipment use only replacement parts supplied by LIFE FITNESS.

MAINTAIN LABELS AND NAME PLATES - Do not remove labels for any reason. They contain important information. If unreadable or missing, contact LIFE FITNESS for a replacement.

EQUIPMENT MAINTENANCE - Preventative maintenance is the key to smooth operating equipment as well as to keep your liability to a minimum. Equipment needs to be inspected at regular intervals.

Ensure that any person(s) making adjustments or performing maintenance or repair of any kind is qualified to do so. LIFE FITNESS will provide service and maintenance training at our corporate facility upon request or in the field if proper arrangements are made.

Before any use, examine all accessories approved for use with the LIFE FITNESS equipment for damage or wear.

Do not attempt to use or repair any accessory approved for use with the LIFE FITNESS equipment which appears to be damaged or worn.

Health and Environmental Regulations Warning - This product may contain chemicals known to the State of California to cause cancer, birth defects, or other reproductive harm. For more information related to the European Commission Regulation (EC) No. 1907/2006 (REACH) and the California Safe Drinking Water and Toxic Enforcement Act of 1986 (Proposition 65), please visit <https://www.lftechsupport.com/web/guest/environmental-regulations-information>.

SAFETY INFORMATION

OPERATING WARNINGS

It is the purchaser's sole responsibility to properly instruct its end users and supervising personnel as to the proper operating procedures of all LIFE FITNESS equipment.

Keep children away from strength equipment. Parents or others supervising children must provide close supervision of children if the equipment is used in the presence of children.

This equipment is not intended for use by children. Keep children under the age of 13 away from the equipment.

Do not allow users to wear loose fitting clothing or jewelry while using equipment. It is also recommended to have users secure long hair back and up to avoid contact with moving parts.

All bystanders must stay clear of all users, moving parts and attached accessories and components while machine is in operation.

CONTACT INFORMATION

For CUSTOMER Service within the United States and Canada:
1-800-351-3737 or customersupport@lifefitness.com

Please call Monday through Friday from 7:00 a.m. to 6:00 p.m. Central Standard Time, and tell them your name, address, and serial number of your Product. They will tell you how to get a replacement part, or if necessary, arrange for service where your Product is located or advise you on how and where to ship the Product for service.

Before shipping:

1. **Obtain** a Return Authorization Number (**RA#**) from Customer Support Services
2. Securely **pack** your Product (use the original shipping carton, if possible)
3. **Write** the RA# on the outside of the carton
4. **Insure** the Product
5. **Include** a letter explaining the defect or problem and a copy of your proof of purchase if you believe the service is covered by warranty.

RETURN ADDRESS:

Life Fitness World Headquarters
Attn: CSS Help Desk
Columbia Centre III - 9525 West Bryn Mawr Avenue
Rosemont, IL 60018

For Product Service Internationally see contact information listed on page 1 of this manual.

WARRANTY

HOW TO OBTAIN PARTS & SERVICE

1. Verify the symptom and review the operating instructions. The problem may be unfamiliarity with the product and its features and workouts.
2. Locate and write down the serial number of the unit.
3. Contact the nearest LIFE FITNESS Customer Support Services group.

WARRANTY COVERAGE

Warranties outside the United States may vary.

*There is no warranty coverage for labor on Strength Products.

Structural Frame (Not coatings)	Hardware/Mechanical
10 Years	90 Days

WARRANTY

WHAT IS COVERED

This LIFE FITNESS commercial exercise equipment is warranted to be free of all defects in material and workmanship.

WHO IS COVERED

The original purchaser or any person receiving the product as a gift from the original purchaser.

WHO PAYS TRANSPORTATION & INSURANCE FOR SERVICE

If the Product or any covered part must be returned to a service facility for repairs, We, LIFE FITNESS, will pay all transportation and insurance charges for the first year. You are responsible for transportation and insurance charge after the first year.

WHAT WE WILL DO TO CORRECT COVERED DEFECTS

We will ship to you any new or rebuilt replacement part or component, or at our option, replace the Product. Such replacement parts are warranted for the remaining portion of the original warranty period.

WHAT IS NOT COVERED

Any failures or damage caused by unauthorized service, misuse, accident, negligence, improper assembly or installation, debris resulting from any construction activities in the Product's environment, rust or corrosion as a result of the Product's location, alterations or modifications without our written authorization, or by failure on your part to use, operate and maintain the Product as set out in your Operation Manual.

All terms of this warranty are void if this product is moved beyond the continental borders of the United States of America (excluding Alaska, Hawaii and Canada) and are then subject to the terms provided by that country's local authorized LIFE FITNESS representative.

OPERATION MANUAL

It is VERY IMPORTANT THAT YOU READ THIS MANUAL before operating the Product. Remember to perform the periodic maintenance requirements specified in the Manual to assure proper operation and your continued satisfaction.

EXCLUSIVE WARRANTY

THIS LIMITED WARRANTY IS IN LIEU OF ALL OTHER WARRANTIES OF ANY KIND EITHER EXPRESSED OR IMPLIED, INCLUDING BUT NOT LIMITED TO THE IMPLIED WARRANTIES OF MERCHANTABILITY AND FITNESS FOR A PARTICULAR PURPOSE, AND ALL OTHER OBLIGATIONS OR LIABILITIES ON OUR PART. We neither assume nor authorize any person to assure for us any other obligation or liability concerning the sale of this Product. Under no circumstances shall we be liable under this warranty, or otherwise, of any damage to any person or property, including any lost profits or lost savings, for any special, indirect, secondary, incidental or consequential damages of any nature arising out of the use of or inability to use this Product. Some states do not allow the exclusion or limitation of implied warranties or of liability for incidental or consequential damages, so the above limitations or exclusions may not apply to you.

CHANGES IN WARRANTY NOT AUTHORIZED

No one is authorized to change, modify or extend the terms of this limited warranty.

EFFECTS OF STATE LAWS

This warranty gives you specific legal rights and you may have other rights which vary from state to state and country by country.

OUR PLEDGE TO YOU

Our Products are designed and manufactured to the highest standards.

We want you to be completely satisfied with our Products and will do everything possible under the terms of this warranty to keep you secure in knowing you have bought the best!

SPECIFICATIONS

WEIGHTS AND DIMENSIONS

STORAGE TYPE	WEIGHT		DIMENSIONS (L X W X H)	
	Imperial	Metric	Imperial	Metric
BASE UNIT	190 lbs	118 kg	25.3" x 36.3" x 67.2"	64.3 cm x 92.3 cm x 170.5 cm
ADD STORAGE TYPES, UP TO TWO, TO THE BASE UNIT				
MAT	+ 8.3 lbs	+ 3.7 kg	25.3" x 41.4" x 67.2"	64.3 cm x 105.2 cm x 170.5 cm
MAT & ROLLERS	+ 25.2 lbs	+ 11.4 kg	25.3" x 52.4" x 67.2"	64.3 cm x 133.2 cm x 170.5 cm
VERTICAL BOSU	+ 12.2 lbs	+ 5.5 kg	25.3" x 47.2" x 67.2"	64.3 cm x 120 cm x 170.5 cm
2-STABILITY BALLS	+ 15.3 lbs	+ 6.9 kg	25.3" x 60.1" x 67.2"	64.3 cm x 152.8 cm x 170.5 cm
3-STABILITY BALLS	+ 23.0 lbs	+ 10.4 kg	25.3" x 60.1" x 67.2"	64.3 cm x 152.8 cm x 170.5 cm
BEAUTY BELLS	+ 23.0 lbs	+ 10.4 kg	25.3" x 41.7" x 67.2"	64.3 cm x 97.7 cm x 170.5 cm
BEAUTY BELL & ROLLERS	+ 27.0 lbs	+ 12.2 kg	25.3" x 42.8" x 75.1"	70.8 cm x 100.2 cm x 170.5 cm

DIMENSIONS

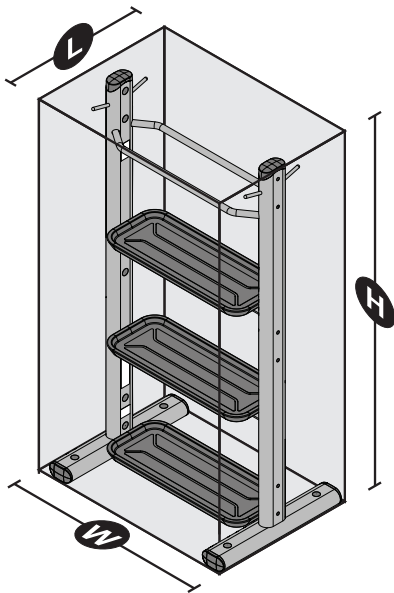

LIVE AREA

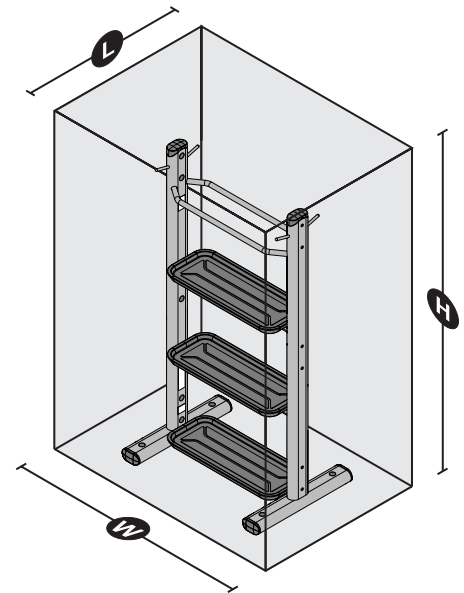

LIVE AREA

STORAGE TYPE	DIMENSIONS (L X W X H)	
	Imperial	Metric
BASE UNIT	37" x 50" x 72"	93.9 cm x 127.0 cm x 182.8 cm
ADD STORAGE TYPES, UP TO TWO, TO THE BASE UNIT		
MAT	37" x 80" x 72"	93.9 cm x 203.2 cm x 182.8 cm
MAT & ROLLERS	37" x 90" x 72"	93.9 cm x 228.6 cm x 182.8 cm
VERTICAL BOSU	37" x 62" x 72"	93.9 cm x 157.5 cm x 182.8 cm
2-STABILITY BALLS	37" x 86" x 72"	93.9 cm x 218.4 cm x 182.8 cm
3-STABILITY BALLS	37" x 86" x 84"	93.9 cm x 218.4 cm x 213.4 cm
BEAUTY BELLS	37" x 80" x 72"	93.9 cm x 203.2 cm x 182.8 cm
BEAUTY BELL & ROLLERS	49" x 80" x 72"	93.9 cm x 203.2 cm x 182.8 cm

WARNING LABELS

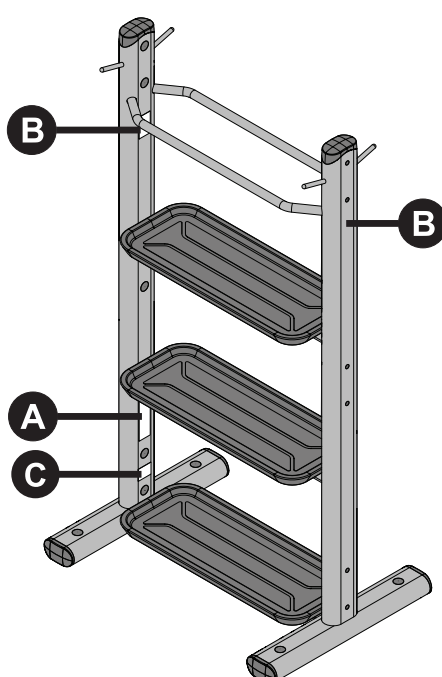

⚠ WARNING

SERIOUS INJURY CAN OCCUR ON THIS EQUIPMENT. YOU MUST FOLLOW THESE PRECAUTIONS TO AVOID INJURY!

1. Before using, read all the warnings and obtain instruction on the use of this machine. Use only for intended exercise. **DO NOT** modify the machine.
2. Obtain a medical exam before beginning any exercise program.
3. Keep body, hair and clothing free of all moving objects.
4. Inspect machine and attachments before use. **DO NOT** use if the machine or attachments appear damaged. **DO NOT** attempt to fix broken or jammed machine or damaged attachments. Notify staff immediately.
5. Children must not be allowed near this machine. Supervise teenagers.
6. **DO NOT** exceed the load rating. Seek Assistance.
7. Manufacturer recommends that all equipment be secured to the floor to stabilize and eliminate rocking or tipping over. Use a licensed contractor.
8. **DO NOT REMOVE THIS LABEL. REPLACE IF DAMAGED.** 1002324-001

⚠ WARNING

TO MINIMIZE THE RISK OF SERIOUS INJURY:

DO NOT lean, stretch or pull on this equipment.

DO NOT attach straps or other devices to this equipment for the purpose of exercising.

1003584-001

Life Fitness

9525 WEST BRYN MAWR AVE
ROSEMONT, IL 60018
USA 1-800-351-3737
CAGE Code 0CMY5
www.LifeFitness.com
Class S - Studio

Model: SAR

Manufactured in the USA with US and Foreign parts
Max. User Wt:
Max Training Wt:
Max Storage Wt: 1216lbs, 552kgs.
S/N: SAR



STORAGE TYPES ONE PER SIDE

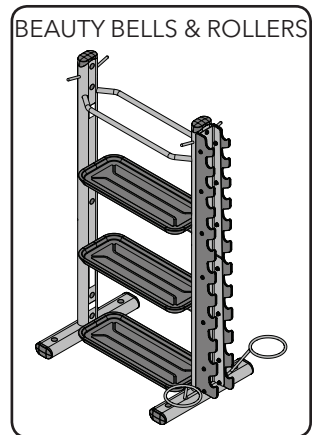
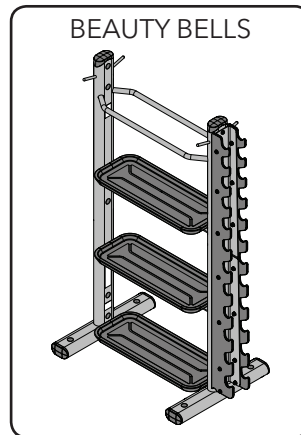
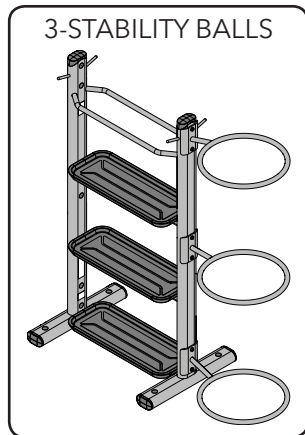
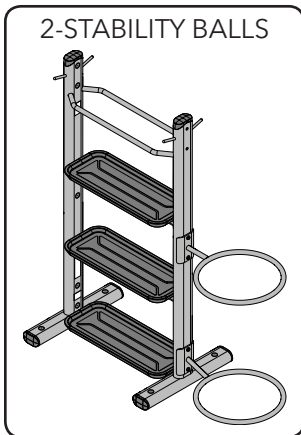
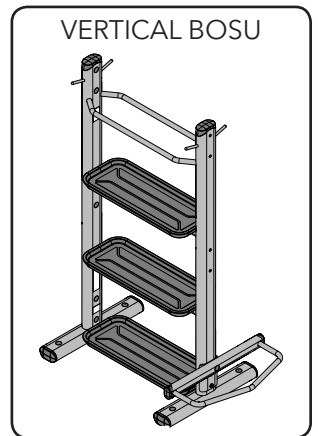
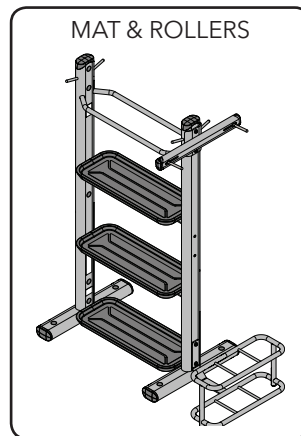
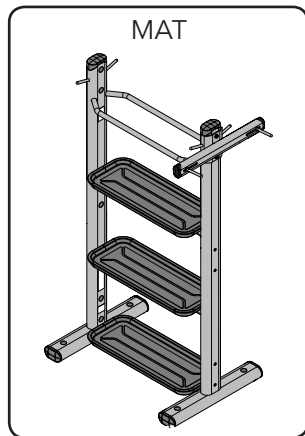
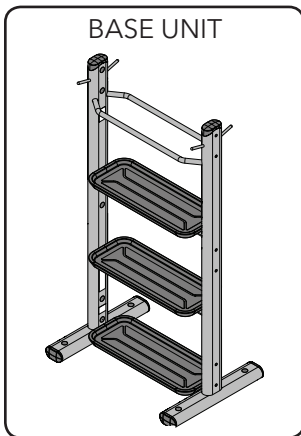

INSTALLATION INSTRUCTIONS

HARDWARE

ITEM	DESCRIPTION
A	M10 X 25mm BOLT
B	WASHER
C	NUT
D	LARGE CAP
E	SMALL CAP
F	MAT HANGER PEG
G	MAT HANGER INSERT
H	SMALL END CAP

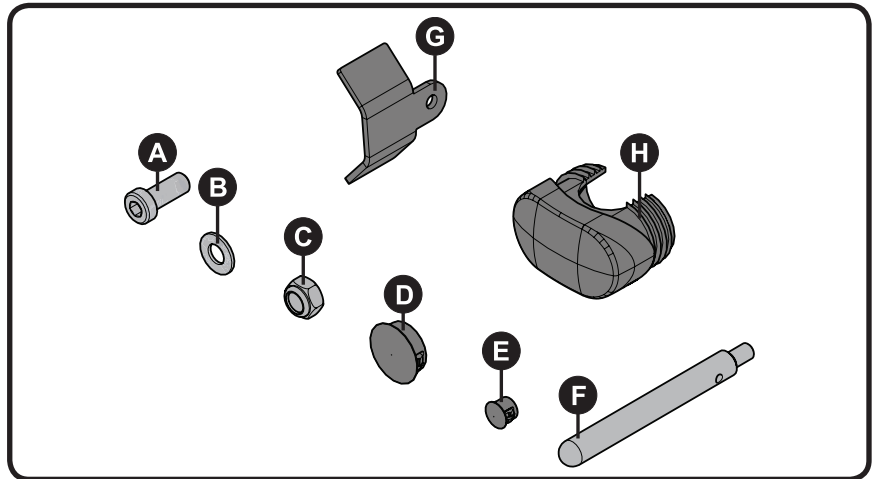

TOOLS REQUIRED

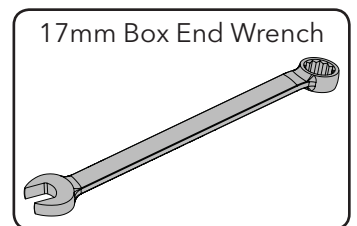
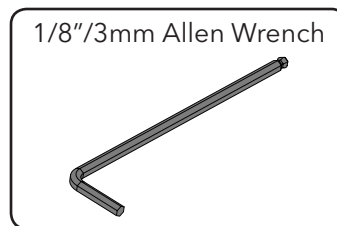
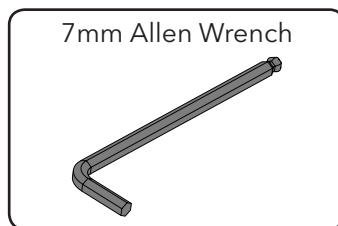
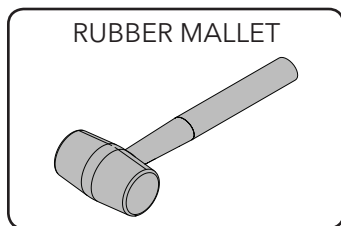

BASE UNIT

STEP 1/1 Finishing Caps

ITEM	QTY.	DESCRIPTION
D	16	LARGE CAP
E	12	SMALL CAP

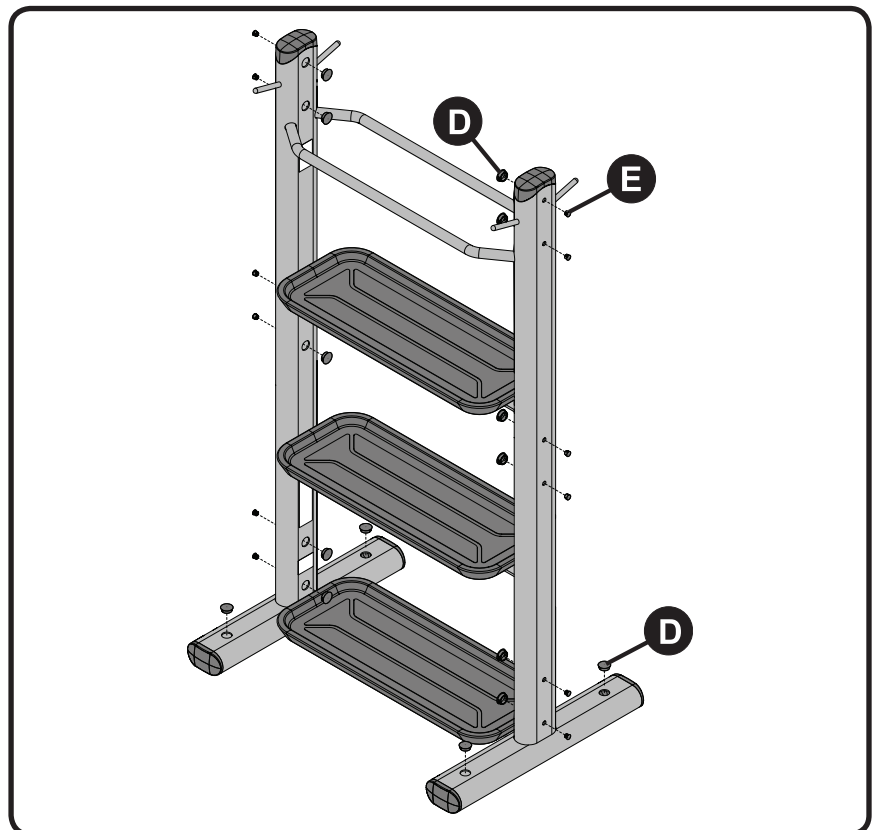

INSTALLATION INSTRUCTIONS

MAT

STEP 1/4 Mount Mat Hanger

ITEM	QTY.	DESCRIPTION
A	2	M10 X 25mm BOLT
B	4	WASHER
C	2	NUT

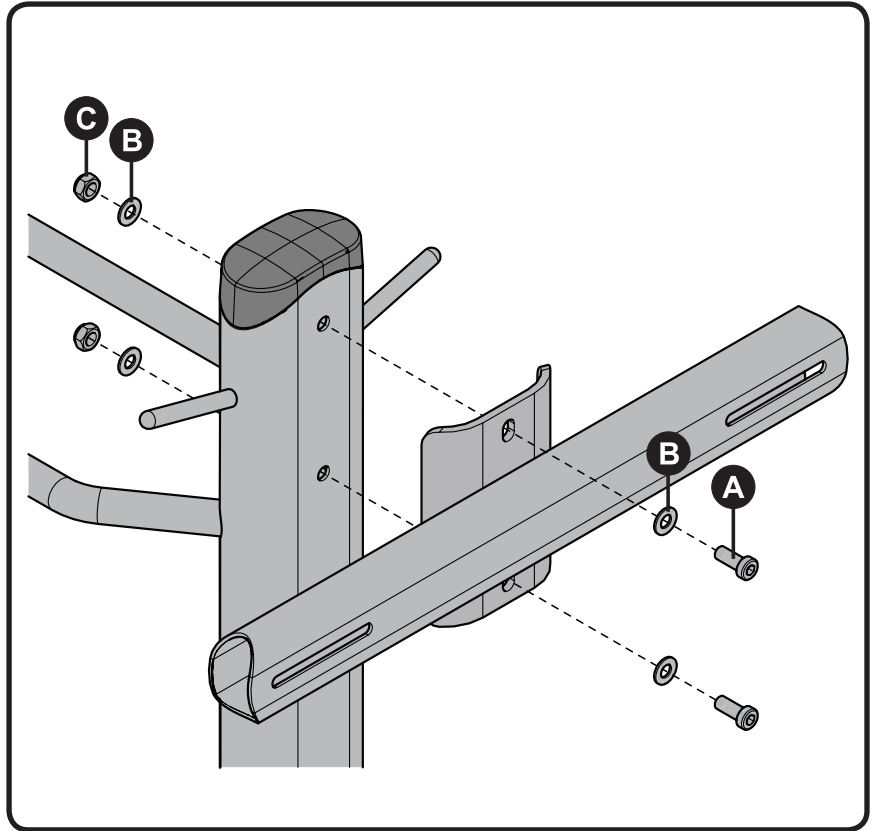
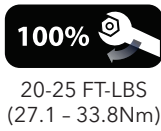

MAT

STEP 2/4 Attach Mat Pegs

ITEM	QTY.	DESCRIPTION
B	2	WASHER
F	2	MAT HANGER PEG
G	2	MAT HANGER INSERT

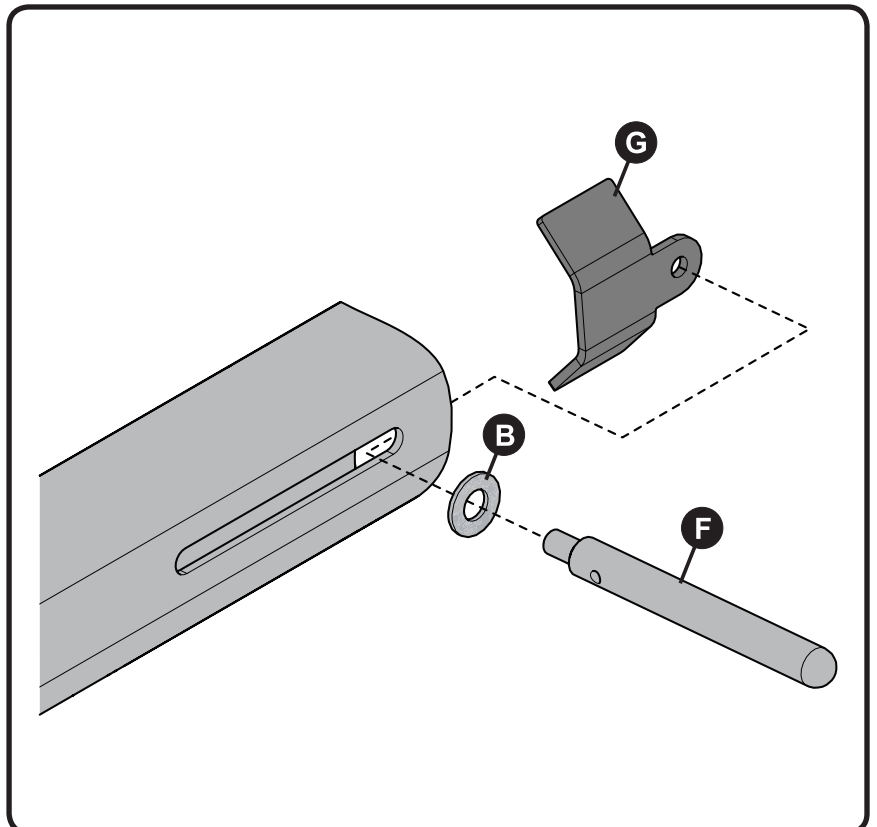

INSTALLATION INSTRUCTIONS

MAT

STEP 3/4 Adjust Pegs

ITEM	QTY.	DESCRIPTION
F	2	MAT HANGER PEG

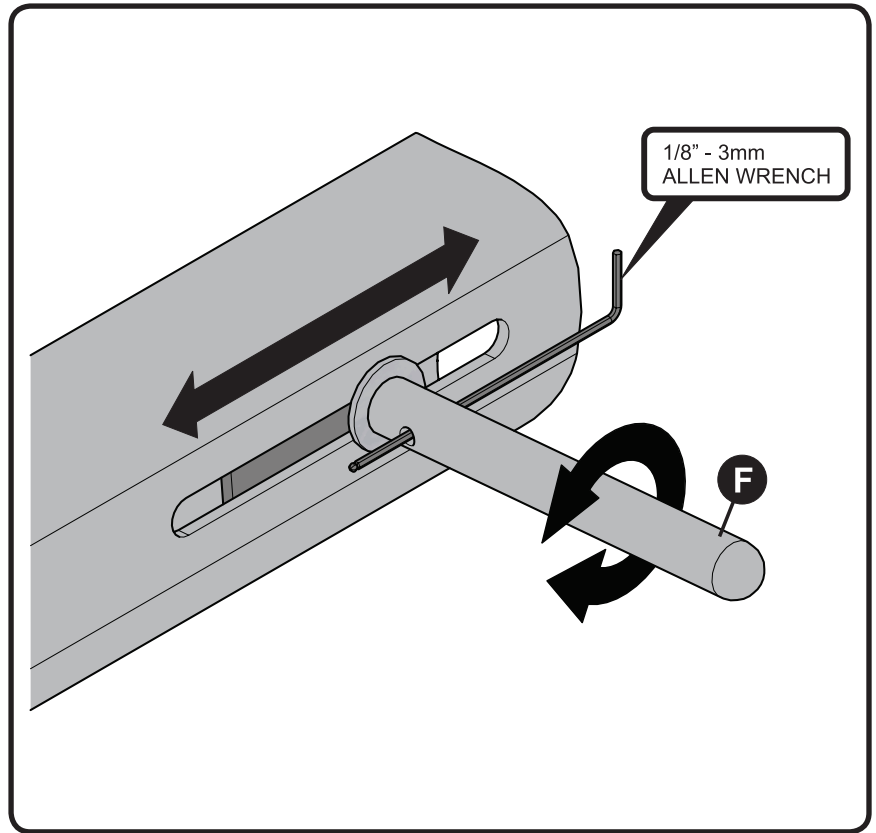
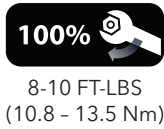

MAT

STEP 4/4 Finishing Caps

ITEM	QTY.	DESCRIPTION
D	16	LARGE CAP
E	10	SMALL CAP
H	2	SMALL END CAP

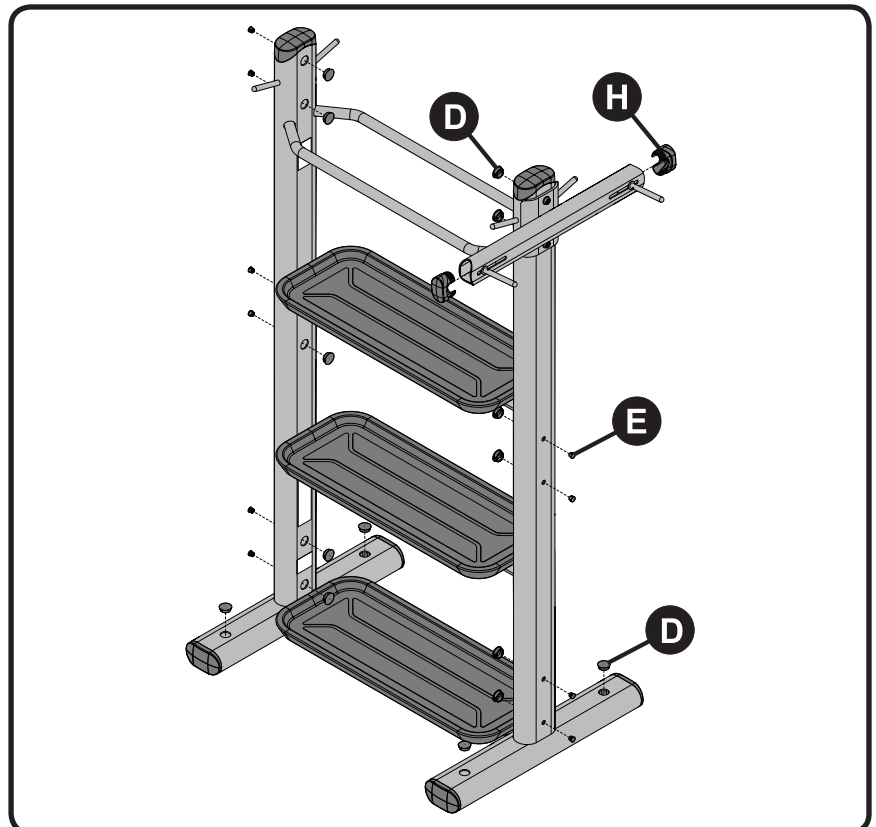

INSTALLATION INSTRUCTIONS

MAT & ROLLERS

STEP 1/2 Mount Base

ITEM	QTY.	DESCRIPTION
A	2	M10 X 25mm BOLT
B	4	WASHER
C	2	NUT



20-25 FT-LBS
(27.1 - 33.8Nm)

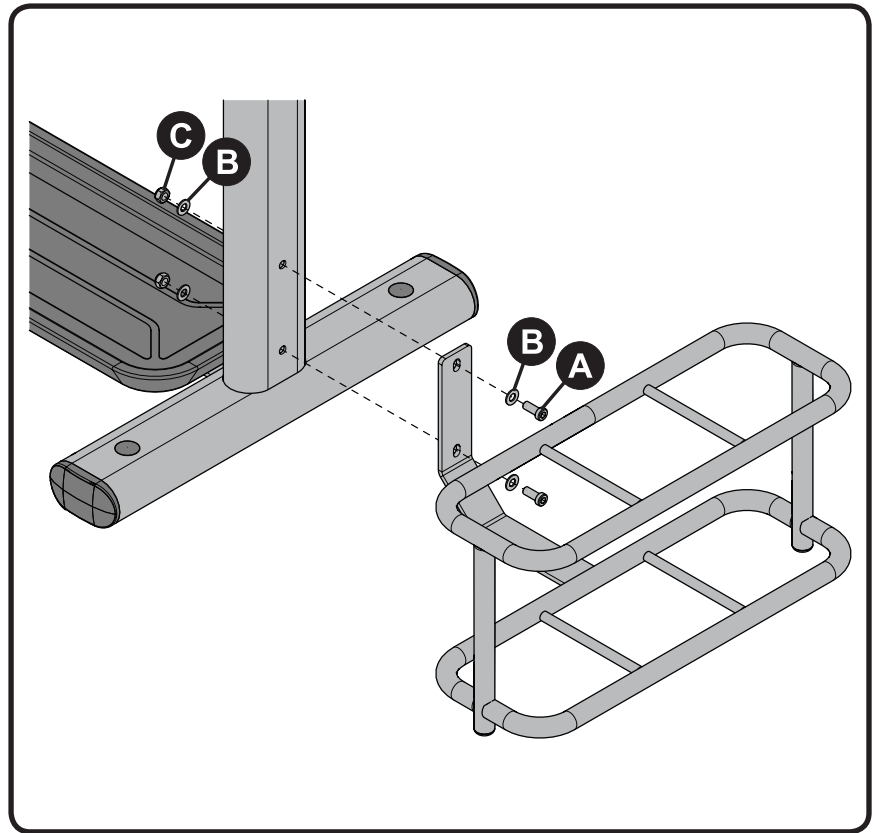

MAT & ROLLERS

STEP 2/2 Finishing Caps

ITEM	QTY.	DESCRIPTION
D	16	LARGE CAP
E	8	SMALL CAP
H	2	SMALL END CAP

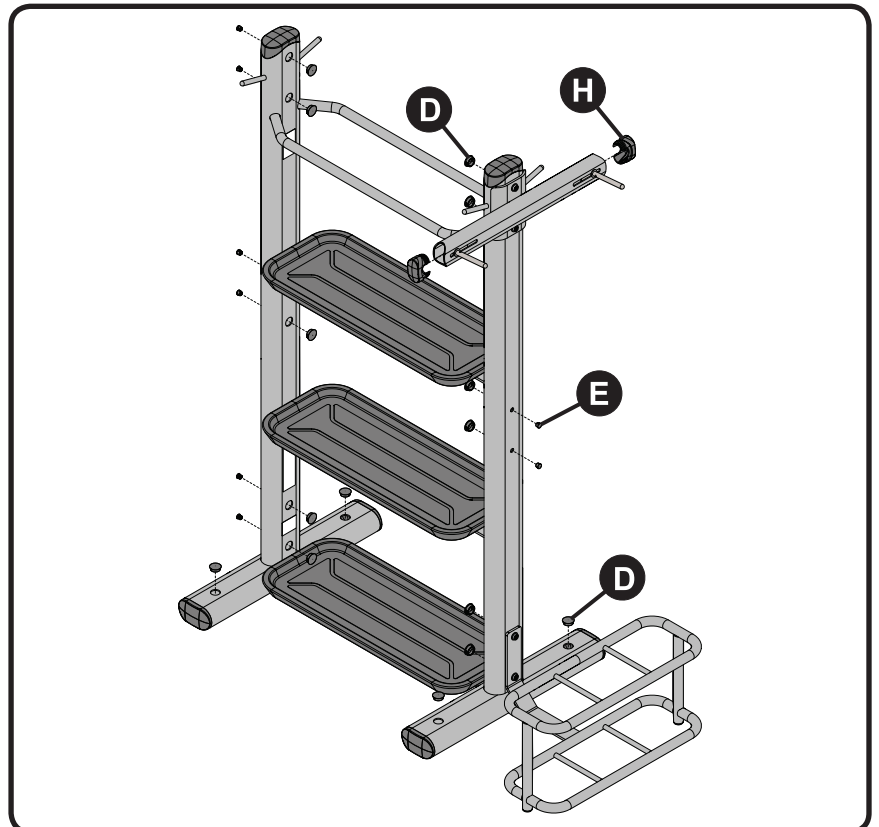

INSTALLATION INSTRUCTIONS

VERTICAL BOSU

STEP 1/2 Mount Weldment

ITEM	QTY.	DESCRIPTION
A	2	M10 X 25mm BOLT
B	4	WASHER
C	2	NUT

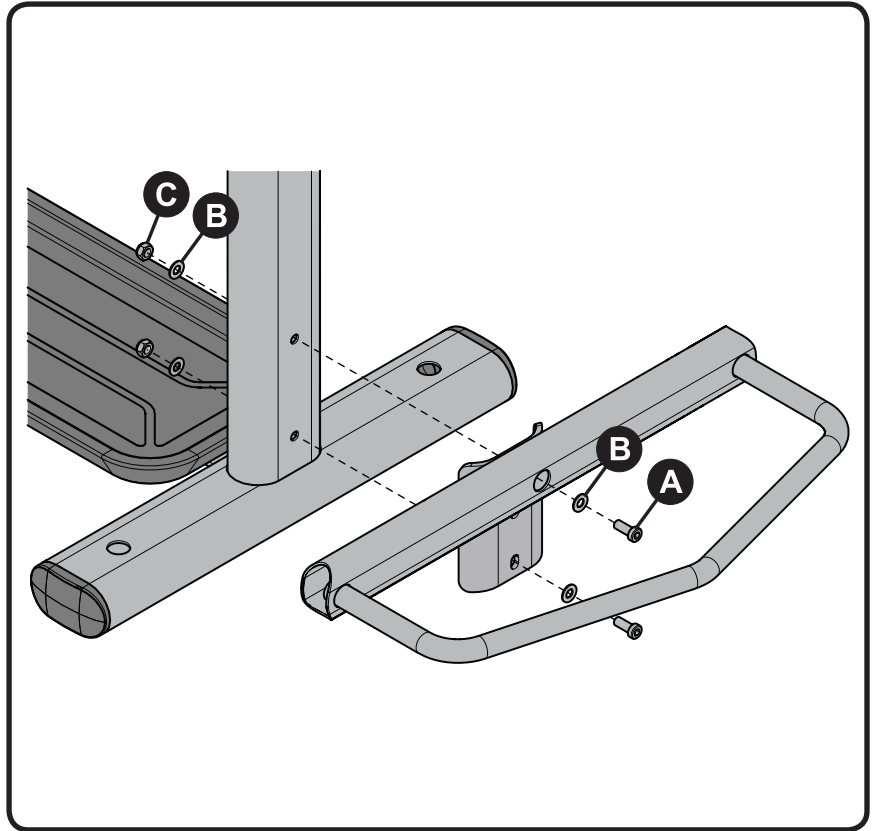
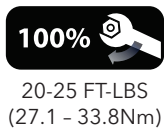

VERTICAL BOSU

STEP 2/2 Finishing Caps

ITEM	QTY.	DESCRIPTION
D	17	LARGE CAP
E	10	SMALL CAP
H	2	SMALL END CAP

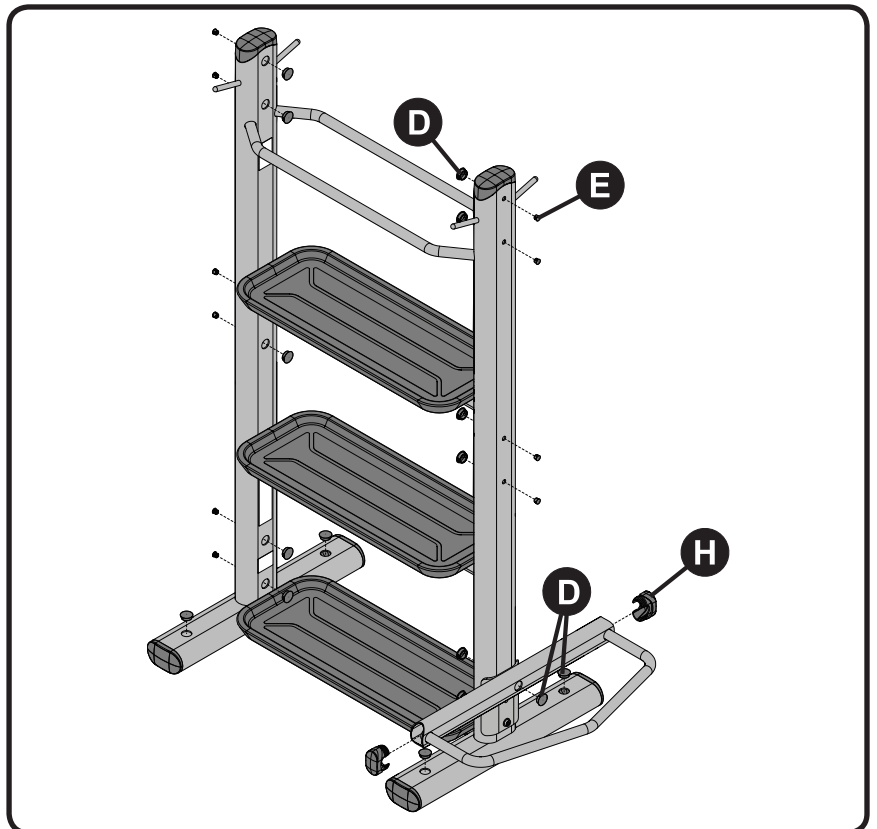

INSTALLATION INSTRUCTIONS

2-STABILITY BALLS

STEP 1/2 Mount Rings

ITEM	QTY.	DESCRIPTION
A	4	M10 X 25mm BOLT
B	8	WASHER
C	4	NUT

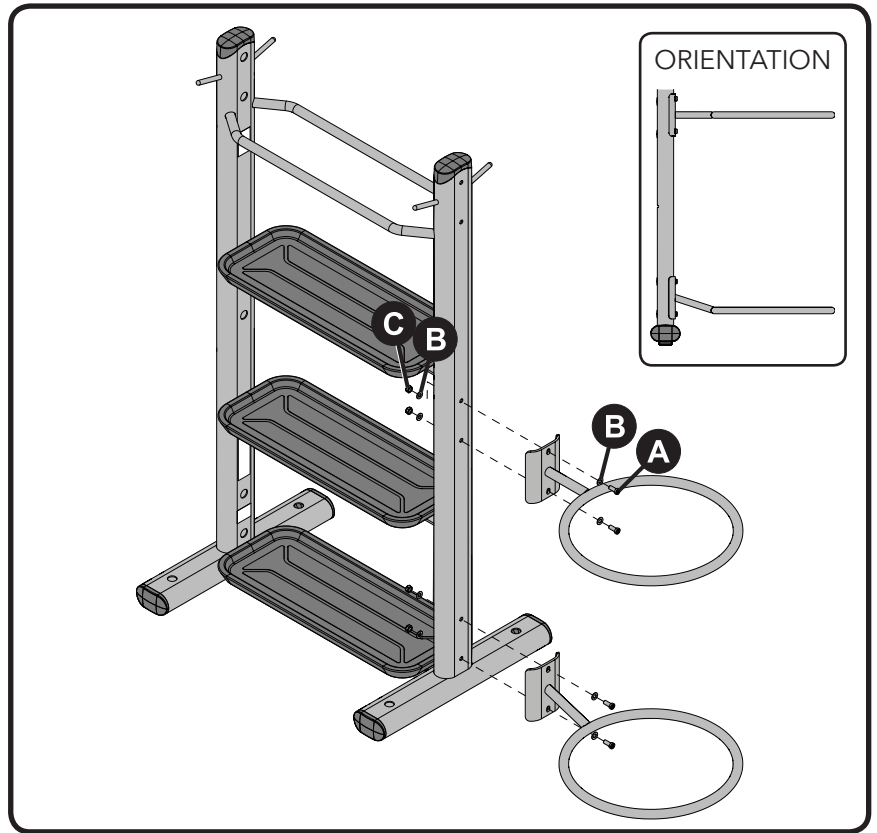
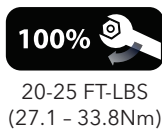

2-STABILITY BALLS

STEP 2/2 Finishing Caps

ITEM	QTY.	DESCRIPTION
D	16	LARGE CAP
E	8	SMALL CAP

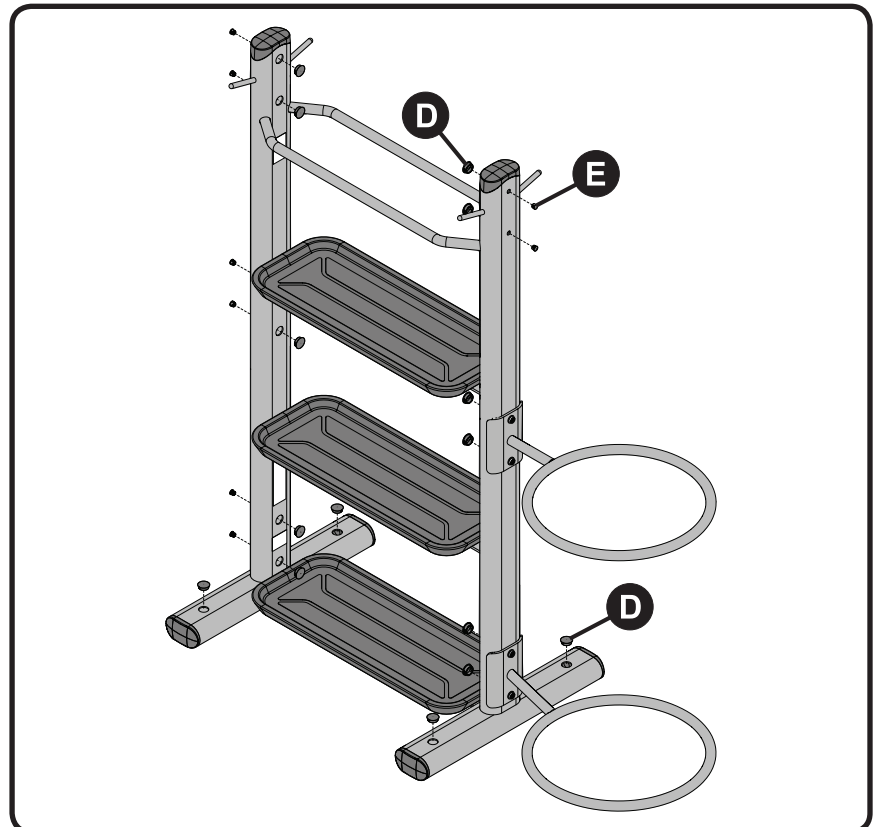

INSTALLATION INSTRUCTIONS

3-STABILITY BALLS

STEP 1/2 Mount Rings

ITEM	QTY.	DESCRIPTION
A	6	M10 X 25mm BOLT
B	12	WASHER
C	6	NUT

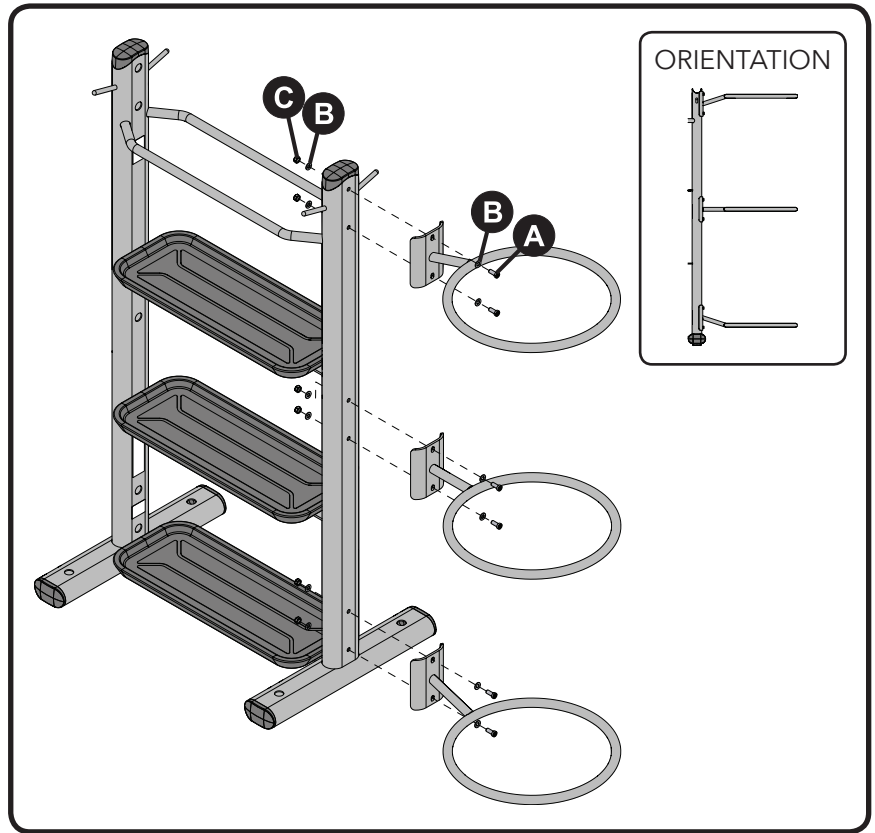
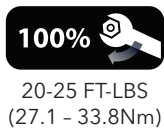

3-STABILITY BALLS

STEP 2/2 Finishing Caps

ITEM	QTY.	DESCRIPTION
D	16	LARGE CAP
E	6	SMALL CAP

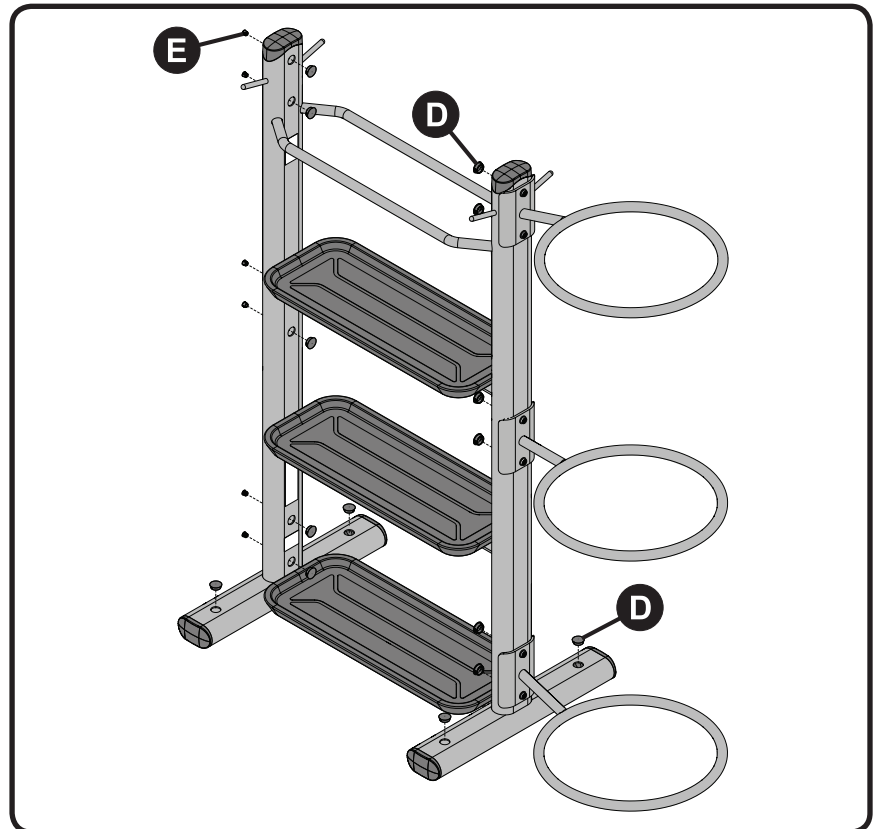

INSTALLATION INSTRUCTIONS

BEAUTY BELLS

STEP 1/3 Mount Braces

ITEM	QTY.	DESCRIPTION
A	4	M10 X 25mm BOLT
B	8	WASHER
C	4	NUT

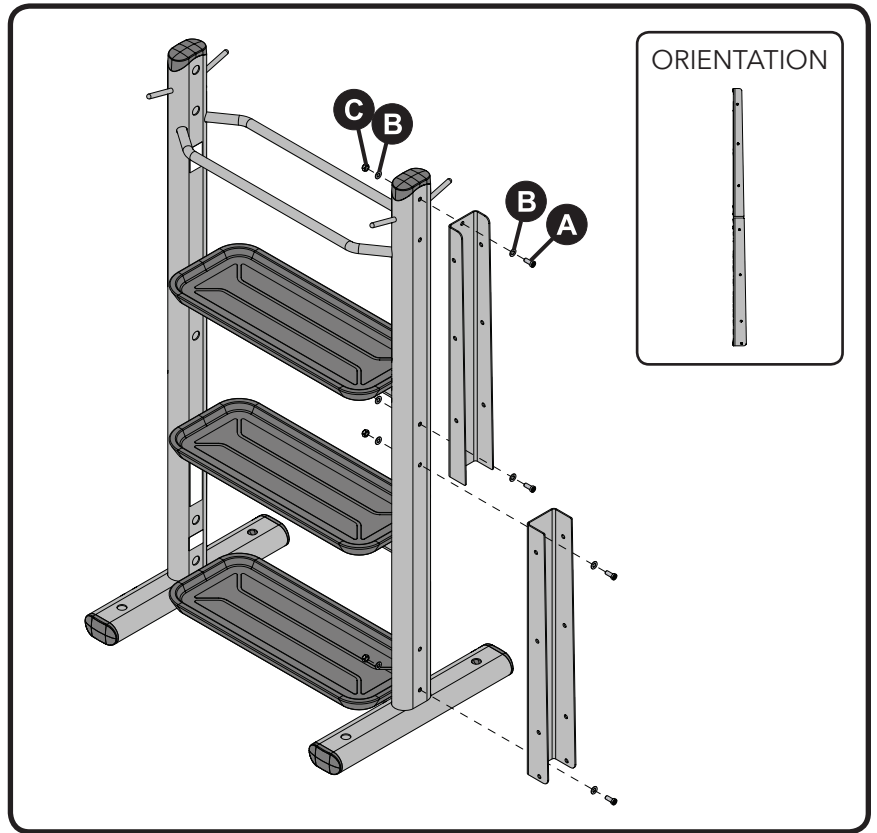
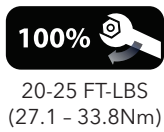

BEAUTY BELLS

STEP 2/3 Mount Hooks

ITEM	QTY.	DESCRIPTION
A	14	M10 X 25mm BOLT
B	28	WASHER
C	14	NUT

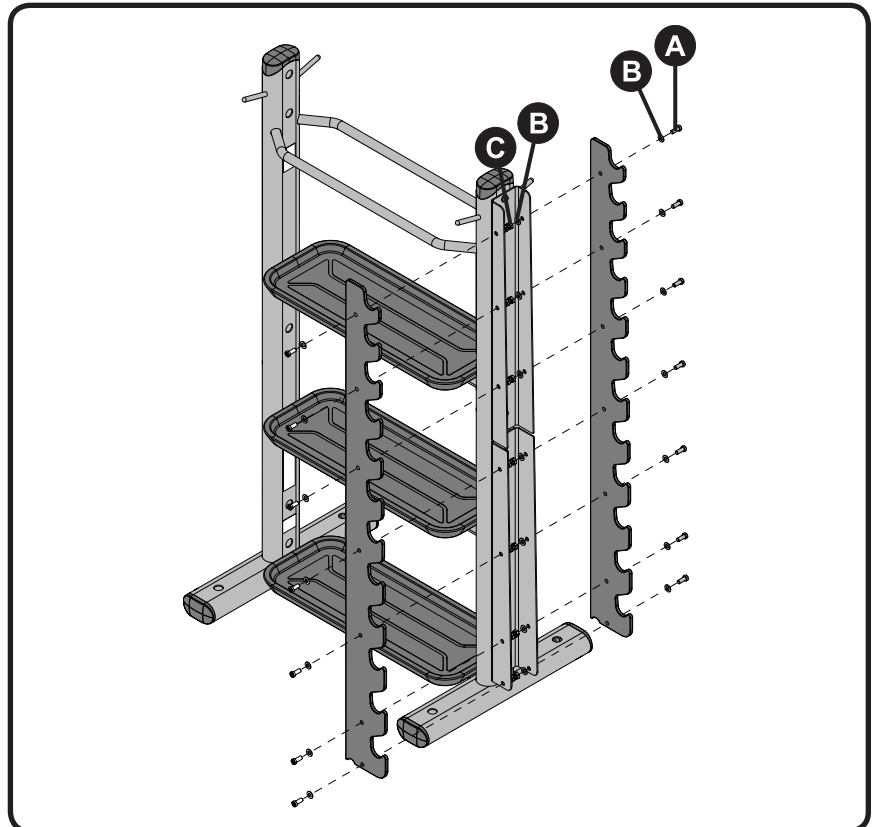

INSTALLATION INSTRUCTIONS

BEAUTY BELLS

STEP 3/3 Finishing Caps

ITEM	QTY.	DESCRIPTION
D	16	LARGE CAP
E	6	SMALL CAP

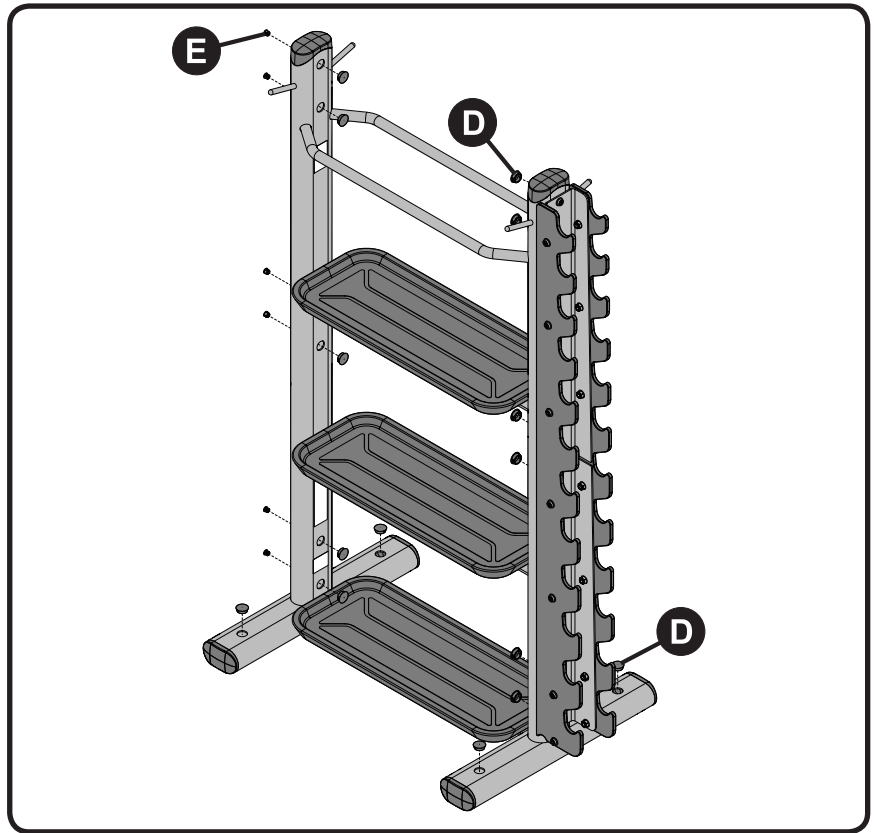

BEAUTY BELLS & ROLLERS

STEP 1/3 Mount Braces

ITEM	QTY.	DESCRIPTION
A	4	M10 X 25mm BOLT
B	8	WASHER
C	4	NUT

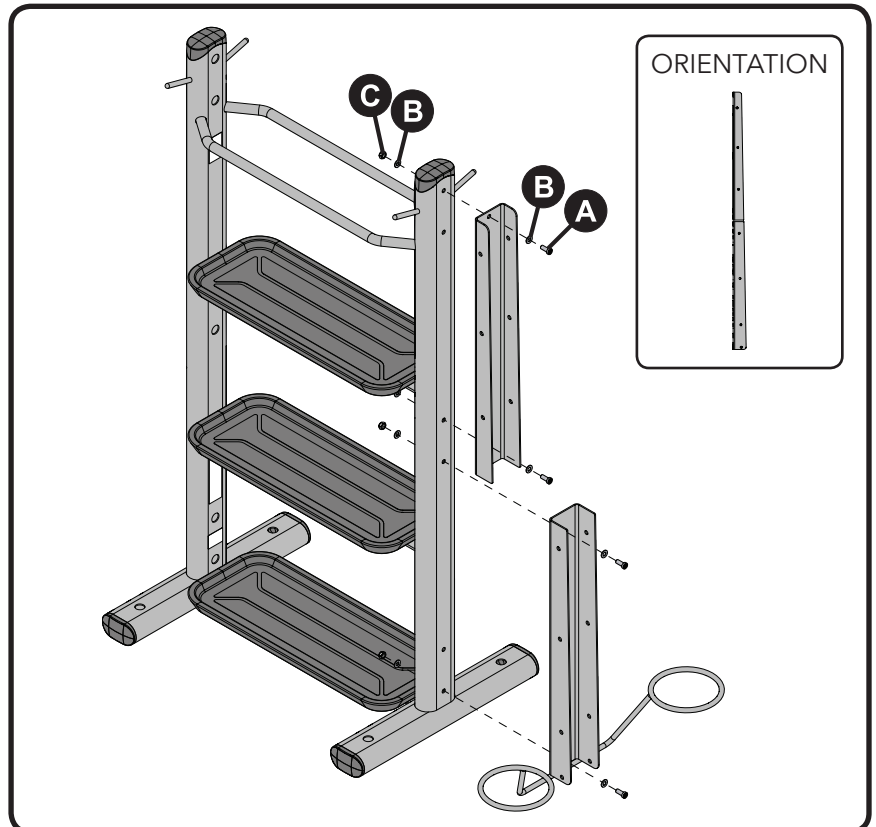

INSTALLATION INSTRUCTIONS

BEAUTY BELLS & ROLLERS

STEP 2/3 Mount Hooks

ITEM	QTY.	DESCRIPTION
A	14	M10 X 25mm BOLT
B	28	WASHER
C	14	NUT

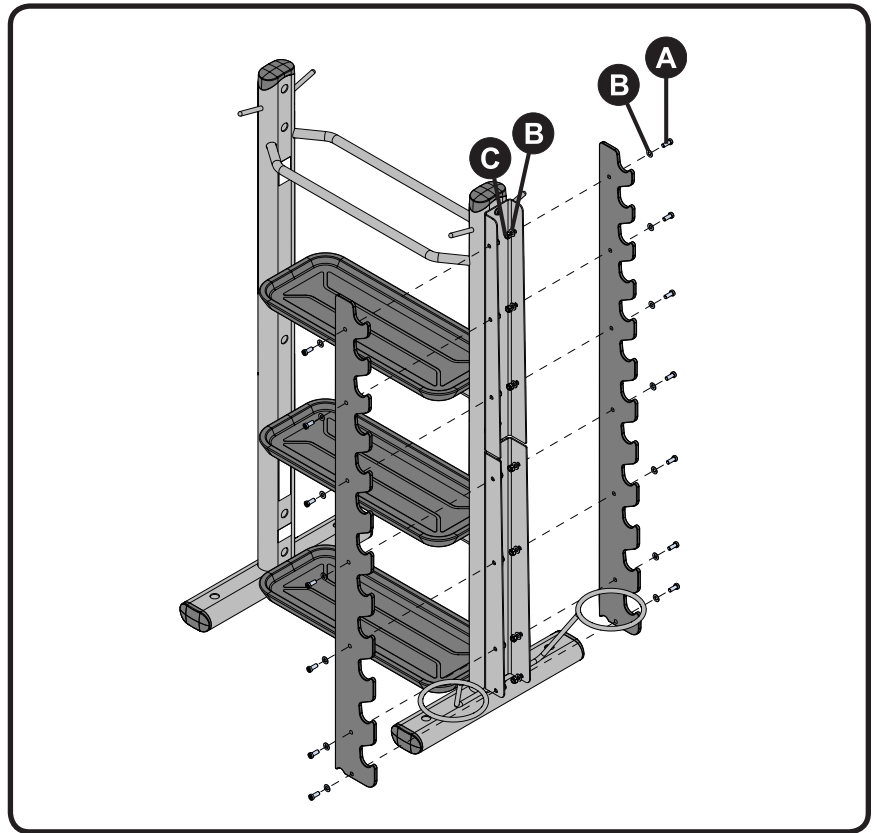
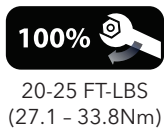

BEAUTY BELLS & ROLLERS

STEP 3/3 Finishing Caps

ITEM	QTY.	DESCRIPTION
D	16	LARGE CAP
E	6	SMALL CAP

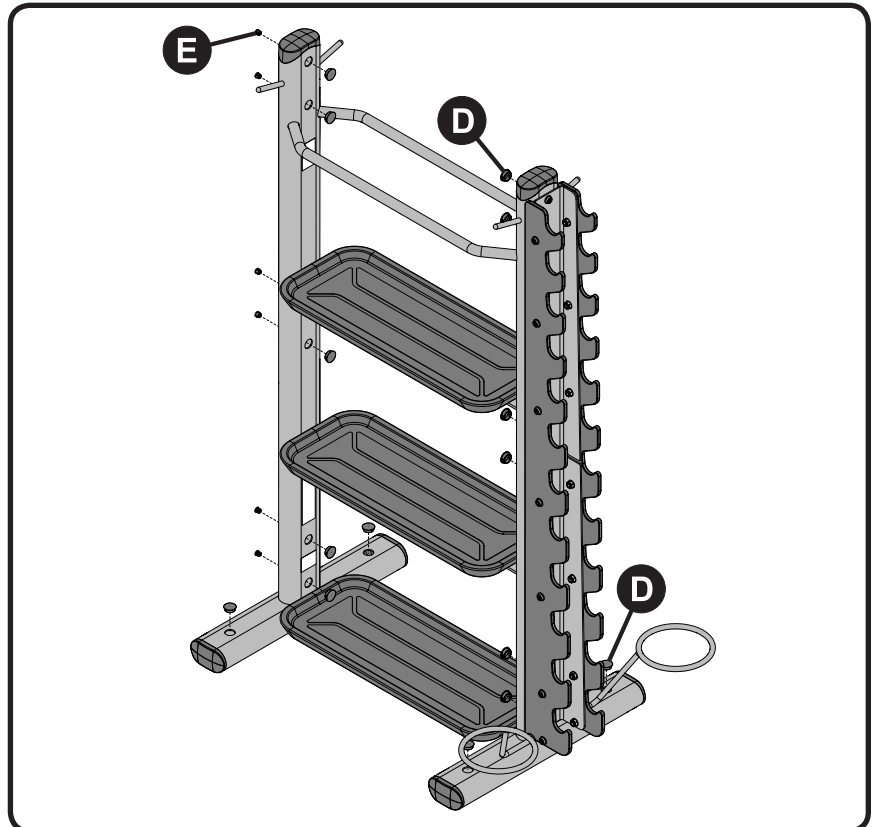

BOLT TO FLOOR GUIDELINES

Introduction

LIFE FITNESS designs its products to be stable when used as designed. Because strength training is dynamic, we cannot predict how users will ultimately use the products in all circumstances. Therefore, LIFE FITNESS **recommends** that the strength training equipment listed below be secured to a solid, level surface to stabilize and eliminate rocking or tipping over.

- Signature Accessory Rack (SAR)

It is the facility's responsibility to adhere to local and regional building codes.

ALL ANCHORS:

- Fasteners must have minimum embedment in concrete floor, not including screed, regardless of wood/tile/rubber over subfloor. (See Anchor Types for maximum subfloor thickness between unit and concrete to equipment foot must be made of flooring or other material (i.e. no air gaps)).
- DO NOT reuse fasteners. Static and Dynamic anchors are designed for one-time use only.
- Factor in equipment's feet height when selecting fastener length.
- Factor in flooring thickness when selecting fastener length.
- It is also recommended to drill an additional 1/2" (12.7mm) of depth beyond the length of the fastener being used to ensure that debris does not block the entry of the anchor.
- Minimum concrete compressive strength: 3000psi (20 N/mm²).

Anchoring

- All anchors must have a minimum embedment into concrete, regardless of wood/tile/rubber/screed over sub-floor.
- Dynamic anchors must have a minimum embedment depth in concrete to ensure maximum security and pull out force. See Anchor Specification for embedment depth minimums.

Building Codes

- It is the facility's responsibility to adhere to local and regional building codes. Please verify with the customer to ensure that they are aware of this.

Carpeting

- If bolted down to carpet flooring, be sure to use a box cutter knife to cut the carpet threads around each foot. This will help avoid the carpet threads from being wrapped around and pulled by the drill bit.

Competitor Product

- The bolt down guidelines and procedures for LIFE FITNESS products were determined by the company's Engineering and Installation Development groups. These guidelines include which anchors to use and positioning of the anchors are required for Life Fitness product.
- LIFE FITNESS does not have that level of specification or engineering input for competitive product.
 - LIFE FITNESS installation teams are not permitted to anchor competitor equipment.

Drilling

- It is also recommended to drill an additional 1/2" (12.7mm) of depth beyond the length of the fastener being used to ensure that debris does not block the entry of the anchor.
- This can be done by marking your drill bit with a piece of tape.
 - While it is recommended that a vacuum be used to clean up debris, this will not account for all the debris that will settle at the bottom of the drilled hole.

Anchor Types

PRODUCT	ANCHOR		Subfloor between unit and concrete 0" to 1/2" (12.7mm) thick	Subfloor between unit and concrete over 1/2" (12.7mm) thick
Signature Accessory Storage Rack SAR	Dynamic	Imperial	HSL-3 M 8/40 LF p/n 9226402	HST M 12 x 115/20 to 295/200 (length depends on subfloor thickness)
		Metric		

Anchor Specifications

DYNAMIC ANCHOR	Minimum Concrete Thickness	Minimum Drill Depth in Concrete	Minimum Concrete Embedment	Minimum concrete compressive strength
HSL-3 M8/40	4-3/4" (120mm)	1/2" beyond anchor length	2-13/32" (60mm)	3000psi
HST M 12	140mm (5-1/2")	10mm beyond anchor length	70mm (2.8")	20 N/mm2

Pullout Force

LIFE FITNESS specifies Hilti™ static and dynamic anchors. According to the anchor manufacturer, the recommended design pullout force (in tension) for the specified anchors, when properly installed in cracked concrete, is provided in the side table. This table should be used for reference only; for additional and up-to-date information on the anchor capabilities or the design pullout force in other substrates, please consult Hilti directly at <https://www.us.hilti.com>.

SELECTED ANCHOR	DESIGN RESISTANCE IN TENSION
HSL-3 M 8/40	2000 lb
HST M12 x 115/20	8 kN
HST M12 x 195/200	8 kN
* Design strength extracted from the Hilti Anchor Fastening Technology Manual issued September 2014.	

Tools Required

Adhere to manufacturer's equipment warnings and guidelines. Follow manufacturer's instructions for proper usage.

Floor scanner/rebar detector (optional)	Safety glasses
1" L-shape SDS rotary hammer	Extension cord
Dead blow hammer	Impact wrench
1/2" x 12" (12mm x 305mm) carbide drill bit (for 1/2" (12mm) anchors)	Vacuum (for debris)

Foot Dimensions

Use below to determine foot specifications.

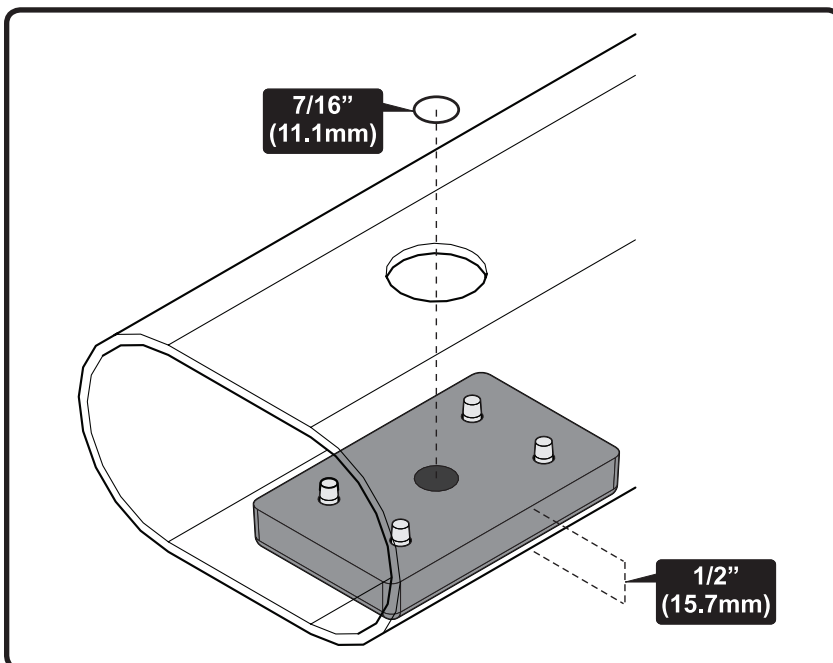

Dynamic Anchor Procedure: HSL-3 M 8/40

If it is possible that the length of your bolt will not provide the minimum requirement of 2.5" (63.5mm) of engagement, a longer anchor should be used.

1. Place unit into position to be mounted and cycle unit to set stance.
2. Wearing protective glasses, drill down into the flooring to the required depth as perpendicular as possible, ensuring that the foot thickness is being accounted for; refer to Anchor Selection and Foot Dimensions.
3. Clear debris from hole and area.
4. Insert fastener and tighten to 18 Foot-Pounds (24Nm).

If the legs/frame do not contact the mounting surface DO NOT pull down with the fastener or anchor. Loosen frame hardware and re-tighten to allow machine to align.

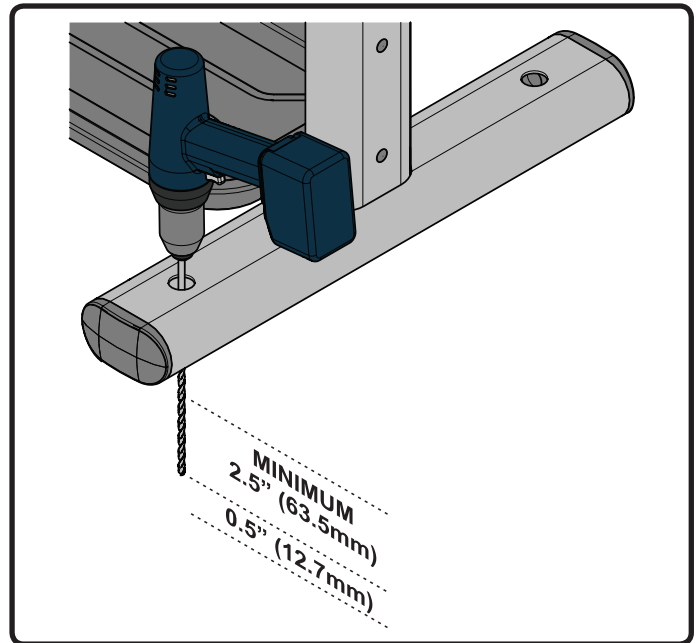

Dynamic Anchor Procedure: HST M12

If it is possible that the length of your bolt will not provide the minimum requirement of 2.5" (63.5mm) of engagement, a longer anchor should be used.

1. Place unit into position to be mounted and cycle unit to set stance.
2. If necessary, cut HST Safety Stud Anchor to length before installation, leaving enough length to ensure proper concrete embedment (See Minimum Concrete Thickness).
3. Wearing protective glasses, drill down into the flooring to the required depth as perpendicular as possible, ensuring that the foot thickness is being accounted for; refer to Anchor Selection and Foot Dimensions.
4. Clear debris from hole and area.
5. Insert fastener and tighten to 44 Foot-Pounds (60Nm).
6. If necessary, cut extra length from top of the anchor with a rotary tool leaving proper concrete engagement and torque requirements.
7. Retighten anchor to 44 Foot-Pounds (60Nm).

