

# Life Fitness 3-Tier Racks

LBR-TF, LBR-TL, LBR-TR, LBR-TS

## Assembly Instructions





## Corporate Headquarters

Columbia Centre III, 9525 Bryn Mawr Avenue, Rosemont, IL 60018 • U.S.A.  
847.288.3300 • FAX: 847.288.3703  
Service phone number: 800.351.3737 (toll-free within U.S.A., Canada)  
Global Website: [www.lifefitness.com](http://www.lifefitness.com)

### International Offices

#### AMERICAS

##### North America

###### Life Fitness, LLC

Columbia Centre III  
9525 Bryn Mawr Avenue  
Rosemont, IL 60018 U.S.A.  
Telephone: (847) 288 3300  
Service Email:  
[customersupport@lifefitness.com](mailto:customersupport@lifefitness.com)  
Sales/Marketing Email:  
[commercialsales@lifefitness.com](mailto:commercialsales@lifefitness.com)

##### Brazil

###### Life Fitness Brasil

Av. Rebouças, 2315  
Pinheiros  
São Paulo, SP 05401-300  
BRAZIL  
SAC: 0800 773 8282 option 2  
Telephone: +55 (11) 3095 5200 option 2  
Service Email: [suportebr@lifefitness.com](mailto:suportebr@lifefitness.com)  
Sales/Marketing Email:  
[vendasbr@lifefitness.com](mailto:vendasbr@lifefitness.com)

##### Latin America and Caribbean\*

###### Life Fitness, LLC

Columbia Centre III  
9525 Bryn Mawr Avenue  
Rosemont, IL 60018 U.S.A.  
Telephone: (847) 288 3300  
Service Email:  
[customersupport@lifefitness.com](mailto:customersupport@lifefitness.com)  
Sales/Marketing Email:  
[commercialsales@lifefitness.com](mailto:commercialsales@lifefitness.com)

#### EUROPE, MIDDLE EAST, and AFRICA (EMEA)

##### Belgium, Netherlands, and Luxemburg

###### Life Fitness (Atlantic) B.V.

Fascinatio Boulevard 230, 4<sup>th</sup> Fl - Bldg B  
3065WB, Rotterdam  
The Netherlands  
+31 88 646 6666  
Service Email:  
[service.benelux@lifefitness.com](mailto:service.benelux@lifefitness.com)  
Sales/Marketing Email:  
[marketing.benelux@lifefitness.com](mailto:marketing.benelux@lifefitness.com)

##### United Kingdom

###### Life Fitness UK LTD

Unit 109<sup>a</sup>  
Lancaster Way Business Park  
Ely, Cambs, CB6 3NX  
Telephone: General Office (+44)  
1353.666017  
Customer Support (+44) 1353.665507  
Service Email: [uk.support@lifefitness.com](mailto:uk.support@lifefitness.com)  
Sales/Marketing Email: [life@lifefitness.com](mailto:life@lifefitness.com)

##### Germany, Austria, and Switzerland

###### Life Fitness Europe GMBH

Neuhofweg 9  
85716 Unterschleißheim  
GERMANY  
Telephone:  
+49 (0) 89 / 31775166 Germany  
+43 (0) 1 / 6157198 Austria  
+41 (0) 848 / 000901 Switzerland  
Service Email:  
[kundendienst@lifefitness.com](mailto:kundendienst@lifefitness.com)  
Sales/Marketing Email:  
[vertrieb@lifefitness.com](mailto:vertrieb@lifefitness.com)

##### Spain

###### Life Fitness IBERIA

C/Frederic Mompou 5,1<sup>o</sup>A  
08960 Sant Just Desvern Barcelona  
SPAIN  
Telephone: (+34) 93.672.4660  
Service Email:  
[servicio.tecnico@lifefitness.com](mailto:servicio.tecnico@lifefitness.com)  
Sales/Marketing Email:  
[info.iberia@lifefitness.com](mailto:info.iberia@lifefitness.com)

#### All Other EMEA Countries and Distributor Business EMEA\*

###### Life Fitness (Atlantic) B.V.

Fascinatio Boulevard 230, 4<sup>th</sup> Fl - Bldg B  
3065WB, Rotterdam  
The Netherlands  
+31 88 646 6666  
Service Email:  
[emeaservicesupport@lifefitness.com](mailto:emeaservicesupport@lifefitness.com)

#### ASIA PACIFIC (AP)

##### Japan

###### Life Fitness Japan, Ltd

4-17-33 Minami Aoyama 1F/B1F  
Minato-ku - Tokyo 107-0062  
Japan  
Telephone: (+81) 0120.114.482  
Fax: (+81) 03-5770-5059  
Service Email: [service.lfj@lifefitness.com](mailto:service.lfj@lifefitness.com)  
Sales/Marketing Email:  
[sales@lifefitnessjapan.com](mailto:sales@lifefitnessjapan.com)

##### Hong Kong

###### Life Fitness Asia Pacific LTD

26/F, Global Trade Square  
21 Wong Chuk Hang Road  
Wong Chuk Hang  
Hong Kong  
Telephone: (+852) 25756262  
Fax: (+852) 25756894  
Service Email: [service.hk@lifefitness.com](mailto:service.hk@lifefitness.com)  
Sales/Marketing Email:  
[marketing.hk.asia@lifefitness.com](mailto:marketing.hk.asia@lifefitness.com)

#### All Other Asia Pacific countries and distributor business Asia Pacific\*

###### Life Fitness Asia Pacific LTD

26/F, Global Trade Square  
21 Wong Chuk Hang Road  
Wong Chuk Hang  
Hong Kong  
Telephone: (+852) 25756262  
Fax: (+852) 25756894  
Service Email: [service.ap@lifefitness.com](mailto:service.ap@lifefitness.com)  
Sales/Marketing Email:  
[marketing.hk.asia@lifefitness.com](mailto:marketing.hk.asia@lifefitness.com)

\*Also check [www.lifefitness.com](http://www.lifefitness.com) for local representation or distributor/dealer

## User and Service Documents Link

---

<https://fn.fit/KnowledgeBase>

<https://fn.fit/PartStore>

Additional information is available online using the links above.

تتوفر معلومات إضافية على الإنترنت باستخدام الرابط أعلاه.

点击上面的链接可在线获取更多信息。

Flere oplysninger er tilgængelige online gennem linket ovenfor.

Bijkomende informatie is online beschikbaar via bovenstaande link.

Vous trouverez plus d'informations en ligne à l'aide du lien ci-dessus.

Zusätzliche Informationen finden Sie online über den oben angegebenen Link.

Ulteriori informazioni sono disponibili online utilizzando il link sopra riportato.

追加情報は上記リンクを使用してオンラインで利用可能です。

상기 링크를 통해 온라인에서 추가 정보를 볼 수 있습니다.

Informações adicionais estão disponíveis on-line, através do link acima.

Дополнительная информация доступна в интернете по ссылке, указанной выше.

Mediante el enlace anterior podrá acceder a información adicional en línea.

Ytterligare information finns online genom att använda länken ovan.

İnternet üzerinden daha fazla bilgi edinmek için yukarıdaki bağlantıyı kullanabilirsiniz.

هناك معلومات إضافية متاحة على الإنترنت باستخدام الرابط أعلاه.

Informazio osagarria eskuragarri dago goiko estekaren bidez.

Допълнителна информация можете да намерите онлайн, като използвате връзката по-горе.

Mitjançant l'enllaç anterior podreu accedir a informació addicional en línia.

使用上面的連結線上提供額外資訊。

Dodatne informacije možete pronaći na internetu sljedeći vezu iznad.

ከላይ የተመጠውን አገናኝ(ሊንክ) በመጠቀም መረጃዎች አንላይን ያገኛሉ።

Lisätietoja on saatavissa verkosta käyttämällä yllä olevaa linkkiä.

Wubetumi anya nsem afoforo aka ho wa websait so denam asem a ewo atifi ho a wubemia so so.

Πρόσθετες πληροφορίες είναι διαθέσιμες online χρησιμοποιώντας το σύνδεσμο παραπάνω.

מידע נוסף אפשר לקבל באינטרנט באמצעות הקישור לעיל.

További információ elérhető online, a fenti hivatkozás segítségével.

Viðbótarupplýsingar eru fáanlegar á netinu með því að smella á tengilinn hér fyrir ofan.

Plus indicium per superum situm potes invenire.

മുകളിലുള്ള ലിങ്ക് ഉപയോഗിച്ച് ഓൺലൈനിൽ കൂടുതൽ വിവരങ്ങൾ ലഭ്യമാണ്.

Ytterligere informasjon er tilgjengelig på nettet via linken ovenfor.

Dodatkowe informacje są dostępne online pod powyższym odnośnikiem.

Informações adicionais estão disponíveis online a usar o link acima.

Informații suplimentare sunt disponibile online, utilizând link-ul de mai sus.

Dodatne informacije dostupne su na mreži putem gornjeg linka.

Ďalšie informácie sú dostupné online na vyššie uvedenom odkaze.

# Table of Contents

## Safety

Safety Information.....	6
Product Labels.....	7
Label Locations.....	8

## Assembly

Unpacking and Disposal of Packaging.....	12
Component and Hardware List.....	12
Tools Required.....	13
Assembly Procedure.....	14

## Product Information

Accessory Rack (LBR-TR).....	17
Hex Dumbbell Rack (LBR-TF).....	18
Dumbbell Rack (LBR-TL).....	19
Dumbbell Rack (LBR-TS).....	20

## Maintenance Procedures

Maintenance Schedule.....	21
---------------------------	----

## Bolt to Floor Guide

Introduction.....	22
Delivery and Installation Tips.....	22
Anchor Type - Static.....	22
Anchor Specifications.....	23
Pullout Force.....	23
Tools Required.....	23
Static Anchor Procedure.....	24
Foot Dimensions.....	25

Life Fitness® is a registered trademark.

Gym Wipes® is a registered trademark of the 2XL Corporation. PureGreen 24 is a trademark of Pure Green.

© Copyright 2026, Life Fitness, LLC. All Rights Reserved. Life Fitness, Hammer Strength, Cybex, ICG and SCIFIT are registered trademarks of Life Fitness, LLC and its affiliated companies and subsidiaries. Disclaimer: Images and specifications are current as of the date of publication and are subject to change.

Columbia Center III - 9525 Bryn Mawr Ave., Rosemont, IL 60018 • 847-288-3300 •  
[www.lifefitness.com](http://www.lifefitness.com) • 1030482-0001 AA • 2026

# 1. Safety

## Safety Information

It is the sole responsibility of the purchaser of Life Fitness products to read the owner's manual and warning labels and instruct all individuals, whether they are the end user or supervising personnel, on proper usage of the equipment.

UNDERSTANDING EACH AND EVERY WARNING TO THE FULLEST IS IMPORTANT. IF ANY OF THESE WARNINGS ARE UNCLEAR, CONTACT Life Fitness CUSTOMER SERVICE IMMEDIATELY AT 1-800-351-3737.

This equipment is categorized as class S per EN ISO 20957-1. As such this equipment is only intended for commercial, institutional and/or studio facilities. It is not intended for home use. Contact Life Fitness with any questions regarding this classification.

It is recommended that all users of Life Fitness exercise equipment be informed of the following information prior to use.

### Operating Warnings

**⚠ WARNING:** This product can expose you to chemicals including 1,3 Butadiene, which is known to the State of California to cause cancer and birth defects or other reproductive harm. For more information go to <http://www.P65Warnings.ca.gov>

- Life Fitness does not warrant nor guarantee that component parts used in the manufacture of products offered under the Life Fitness brand are latex-free. Users of these products must take all necessary precautions to prevent accidental contact that could lead to an adverse latex reaction.
- It is the purchaser's sole responsibility to properly instruct its end users and supervising personnel as to the proper operating procedures of all equipment.
- This equipment is not intended for use by children. Keep children under the age of 14 away from the machine.
- Do not allow users to wear loose fitting clothing or jewelry while using equipment. It is also recommended to have users secure long hair back and up to avoid contact with moving parts.
- All bystanders must stay clear of all users, moving parts and attached accessories and components while machine is in operation.

### Access Control

- Life Fitness recommends that all commercial fitness equipment be used in a supervised area. It is recommended that the equipment be located in an access controlled area. Control is the responsibility of the facility owner.

### Installation

- Life Fitness recommends that all equipment be secured to a solid, level surface to stabilize it and eliminate rocking or tipping over. This must be performed by a licensed contractor. See [Bolt to Floor Guide](#) for installation procedure.

### Proper Usage

- Do not use any equipment in any way other than as designed or intended by the manufacturer. It is imperative that Life Fitness equipment is used properly to avoid injury.
- Injuries may result if exercising improperly or excessively. It is recommended that all individuals consult a physician prior to commencing an exercise program. If at any time during exercise you feel faint, dizzy or experience pain, STOP EXERCISING and consult your physician.

### Inspection

- DO NOT attempt to use or repair any accessory approved for use with the equipment which appears to be damaged or worn.
- DO NOT use or permit use of any equipment that is damaged and/or has worn or broken parts. For all Life Fitness equipment, use only replacement parts supplied by Life Fitness.
- Maintain labels, name plates and instructional placards. Do not remove labels or instructional placards for any reason. They contain important information. Contact Customer Support to replace any worn, damaged, or unreadable labels or instructional placards and to ensure that you are always using the latest version of labels and instructional placards.
- Equipment Maintenance - Preventative maintenance is the key to smooth operating equipment as well as to keep your liability to a minimum. Equipment needs to be inspected at regular intervals.
- Ensure that any person(s) making adjustments or performing maintenance or repair of any kind is qualified to do so. Life Fitness will provide service and maintenance training at our corporate facility upon request or in the field if proper arrangements are made.
- Before use, examine all accessories approved for use with the Life Fitness equipment for damage or wear.

## Plate Loaded, Free Weight, and Body Weight Systems

- Never exceed the load rating for any plate loaded station, body weight station, bench or other free weight device; including specific weight rod and band peg limits. See machine specifications for load limit information.
- Contact a Life Fitness representative with any questions regarding proper weights and loading.

## Warnings and Cautions

- Warning labels indicate a potentially hazardous situation that could result in serious injury or death if the precautions are not observed.
- Caution labels indicate a potentially hazardous situation that could result in serious injury or damage to machine if the precautions are not observed.
- Contact [Customer Support Services](#) to replace any worn, damaged, or unreadable labels and to ensure that you are always using the latest version of labels.

## Product Labels

### General Warning



# WARNING

## SERIOUS INJURY CAN OCCUR ON THIS EQUIPMENT. YOU MUST FOLLOW THESE PRECAUTIONS TO AVOID INJURY!

1. Before using, read all the warnings and obtain instruction on the use of this machine. Use only for intended exercise. **DO NOT** modify the machine.
2. Obtain a medical exam before beginning any exercise program.
3. Keep body, hair and clothing free of all moving objects.
4. Inspect machines and attachments before use. **DO NOT** use if the machine or attachments appear to be damaged. **DO NOT** attempt to fix broken or jammed machine or damaged attachments. Notify staff immediately.
5. Children must not be allowed near this machine. Supervise teenagers.
6. Manufacturer recommends that all equipment be secured to the floor to stabilize and eliminate rocking or tipping over. Use a licensed contractor.
7. **DO NOT REMOVE THIS LABEL. REPLACE IF DAMAGED.**

### FCC Compliant

EN ISO 20957  
TSCA Title VI Compliant

**CE UK CA**

THIS DEVICE COMPLIES WITH PART 15 OF THE FCC RULES. OPERATION IS SUBJECT TO THE FOLLOWING TWO CONDITIONS: (1) THIS DEVICE MAY NOT CAUSE HARMFUL INTERFERENCE, AND (2) THIS DEVICE MUST ACCEPT ANY INTERFERENCE RECEIVED, INCLUDING INTERFERENCE THAT MAY CAUSE UNDESIRE OPERATION.

### Serial Number

*LifeFitness*

9525 Bryn Mawr Ave  
Rosemont, IL 60018  
USA 1-847-288-3300  
www.lifefitness.com

Bijdorplan 25-31  
2992 LB Barendrecht  
The Netherlands  
+31 0 180 646 666

CAGE:  
DCMY5  
Class: S

Model:  
XXX

Max User Wt: XXXlbs XXXkgs  
Max Training Wt: XXXlbs XXXkgs  
Max Storage Wt: XXXlbs XXXkgs

SN: XXXXXXXXXXXXX



Manufactured in the USA with US and Foreign parts

**Label Locations**  
**Accessory Rack (LBR-TR)**

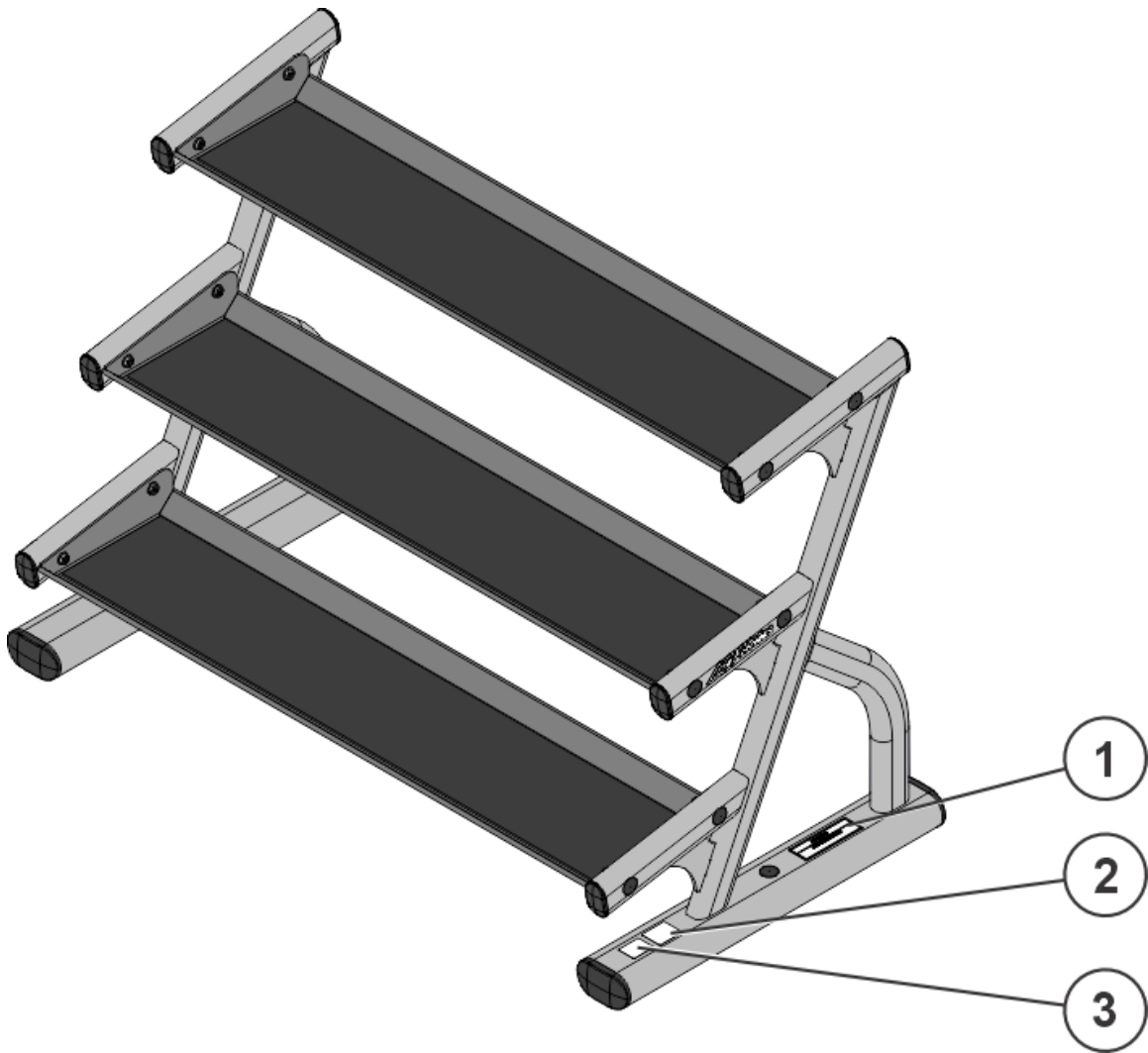

Item	Description	Qty.
1	General Warning	1
2	Serial Number	1
3	FCC Compliant	1

# Hex Dumbbell Rack (LBR-TF)

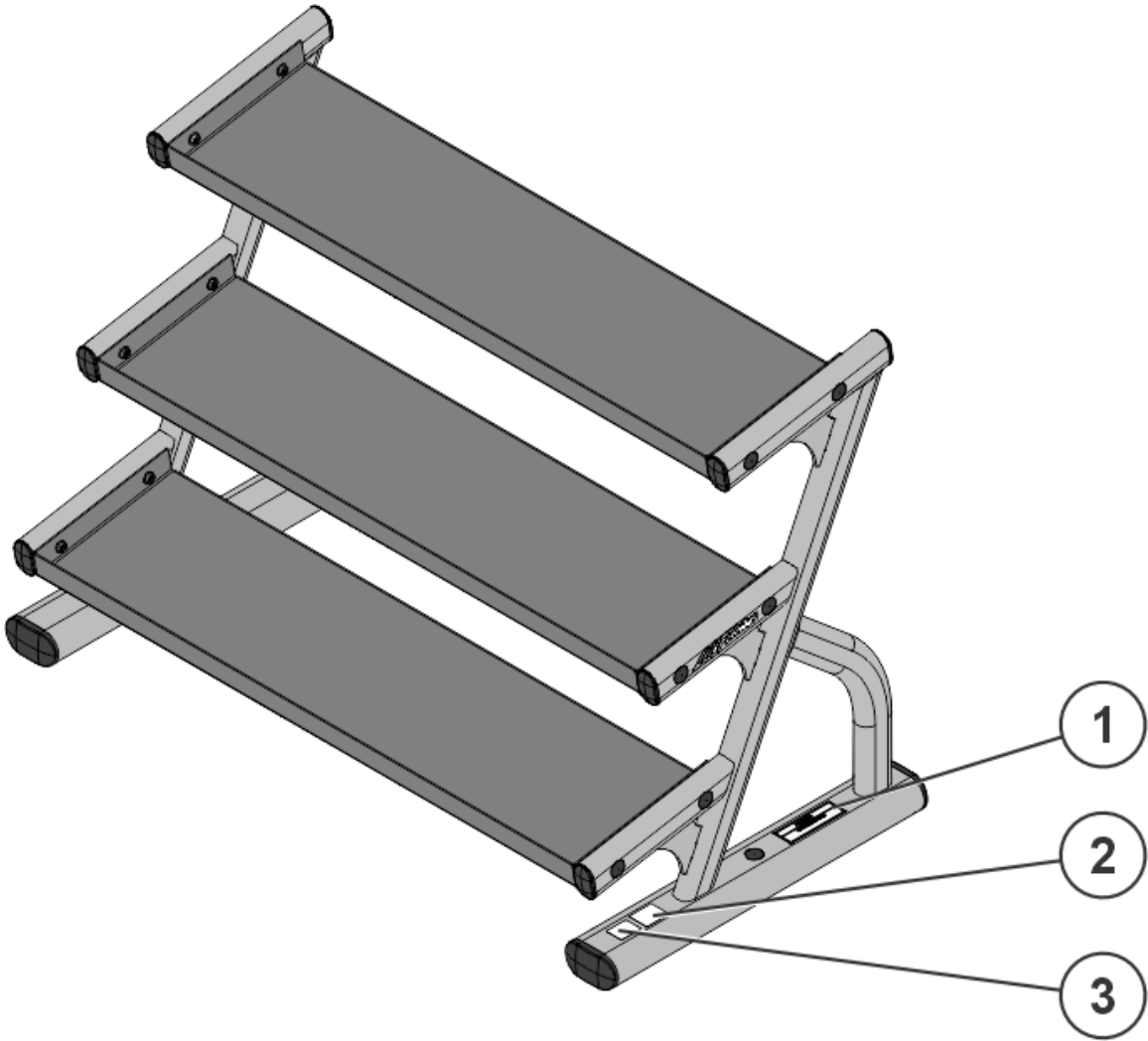

Item	Description	Qty.
1	General Warning	1
2	Serial Number	1
3	FCC Compliant	1

## Dumbbell Rack (LBR-TL)

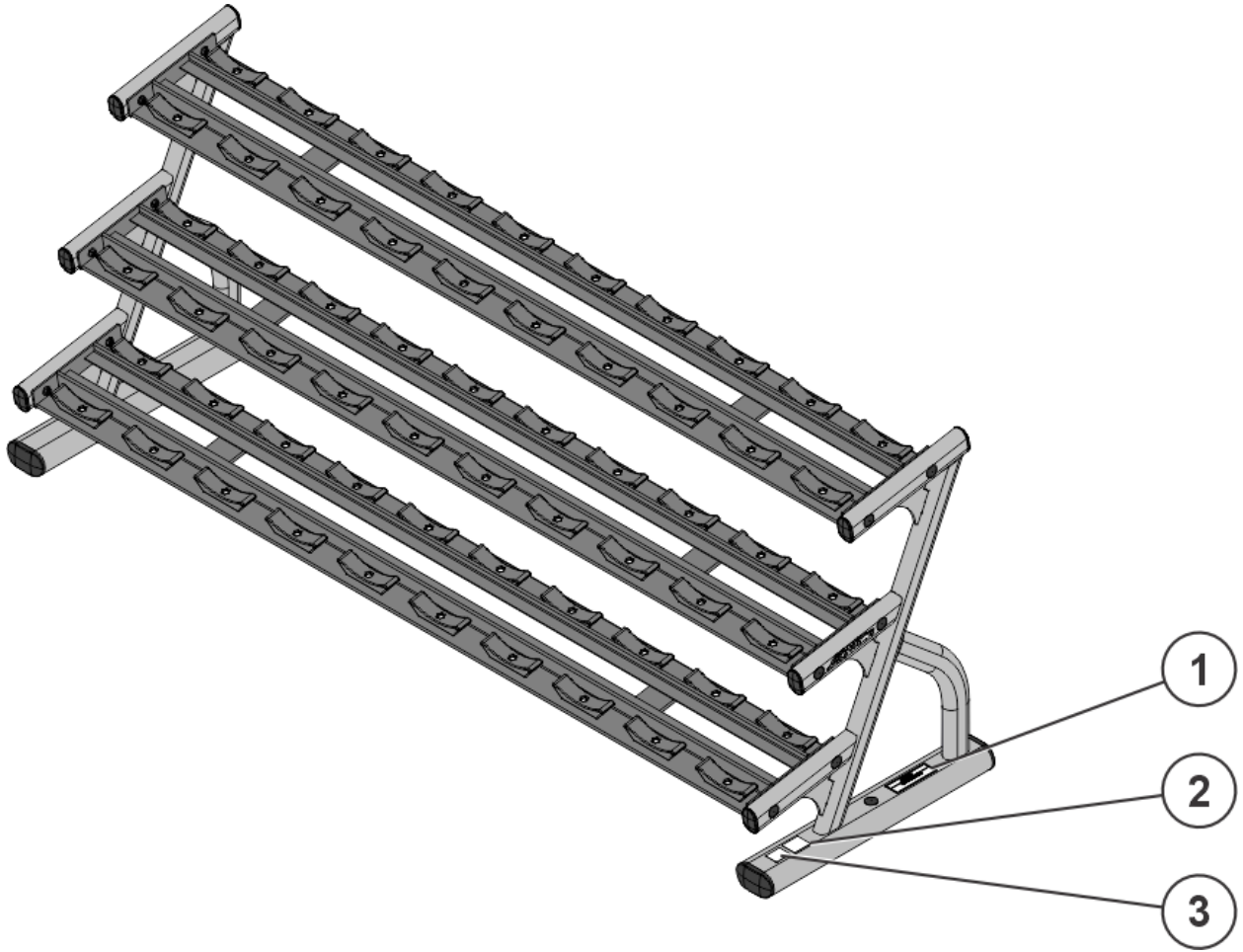

Item	Description	Qty.
1	General Warning	1
2	Serial Number	1
3	FCC Compliant	1

# Dumbbell Rack (LBR-TS)

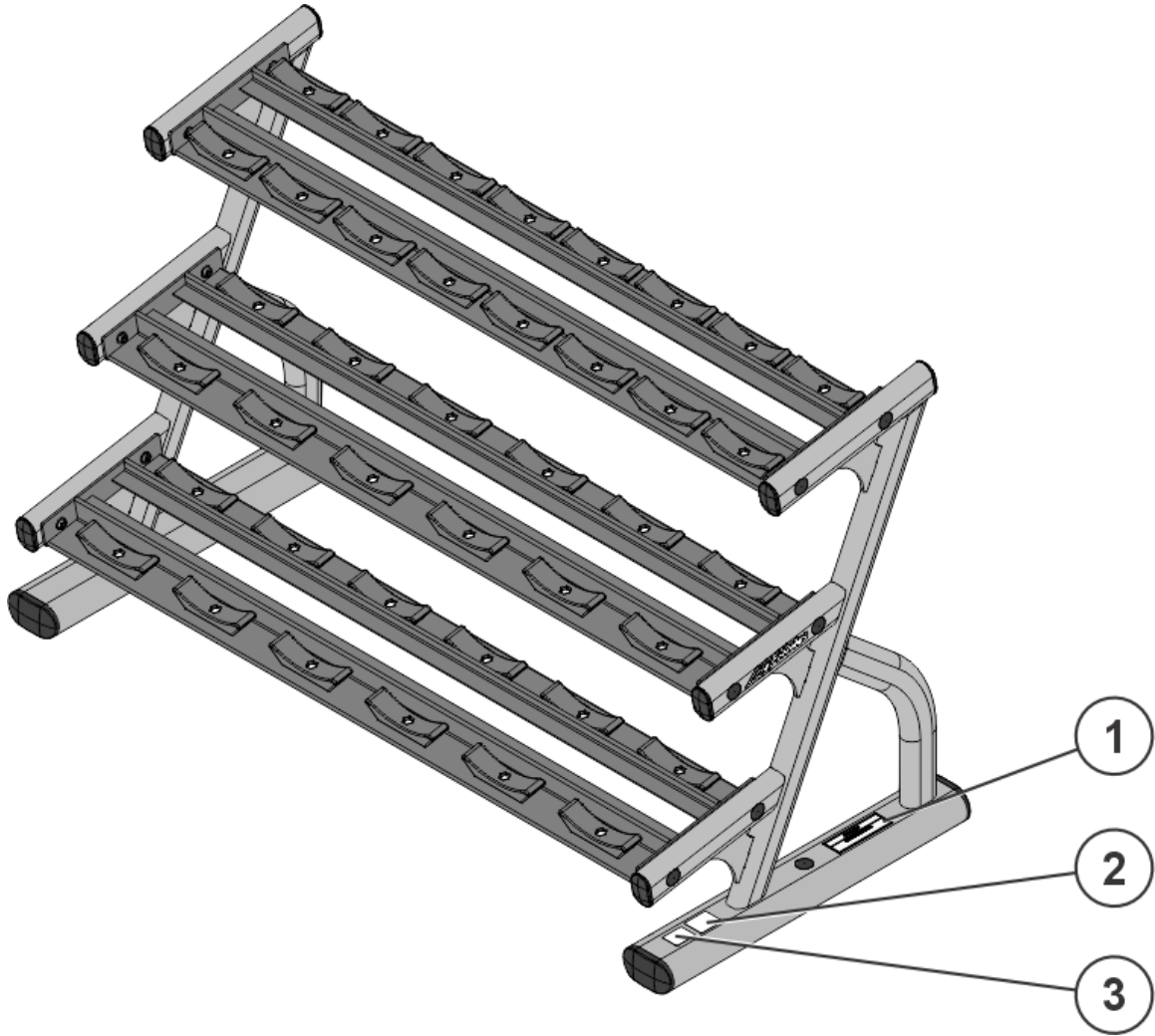

Item	Description	Qty.
1	General Warning	1
2	Serial Number	1
3	FCC Compliant	1

## 2. Assembly

### Unpacking and Disposal of Packaging

Carefully unpack the fitness equipment as described in the assembly manual and inspect all components for damage. Make sure to remove all packaging materials before assembling and using the product. Keep small parts and plastic materials out of reach of children to prevent suffocation and injury hazards.

All packaging materials used for this product are designed to be recyclable or reusable. Please dispose of packaging materials responsibly and in accordance with local, regional, and national regulations. Separate materials such as cardboard, paper, plastics, and protective foams and place them in the appropriate recycling or waste collection streams.

Do not dispose of packaging materials with household waste unless permitted by local regulations. In regions where applicable, follow specific environmental directives (such as recycling, extended producer responsibility, or waste electrical and electronic equipment requirements) to minimize environmental impact.

By properly recycling or disposing of packaging materials, you help conserve resources and support environmental sustainability. See the following [Cardio and Strength Product Install Packaging Removal and Disposal Knowledge Base](#) article for additional information.



### Component and Hardware List

#### Components

Item	Description	Qty.
1	Left Frame	1
2	Right Frame	1
3	Tray	3

#### Hardware

Item	Description	Qty.
1	Hardware Pack	1
2	3/8" Flat Washer	12
3	M10 Hex Nylock Nut	12
4	Hole Plug	14
5	M10 x 25mm Bolt	12

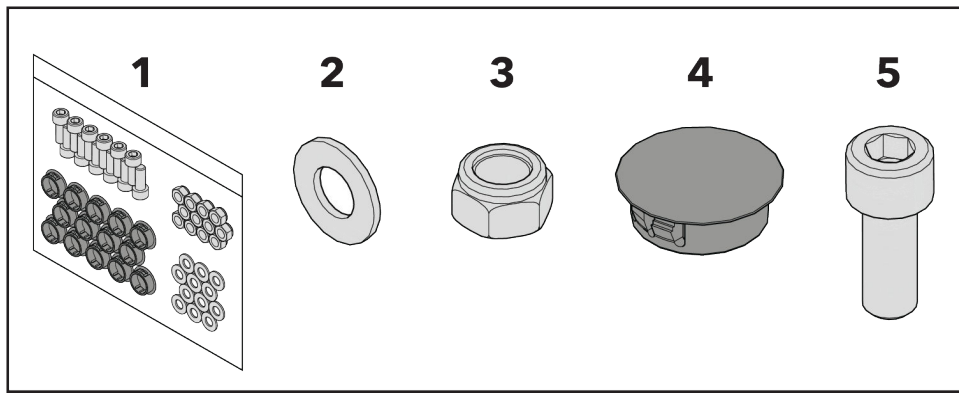

## Tools Required

- 16 mm socket wrench
- 17 mm socket wrench
- 7 mm Allen wrench
- Torque wrench
- Rubber mallet

# Assembly Procedure

## Assemble TF/TR

The following procedure applies to the LBR-TF and LBR-TR.

1. Loosely install bolts, washers and hex nuts securing the trays onto the left frame.

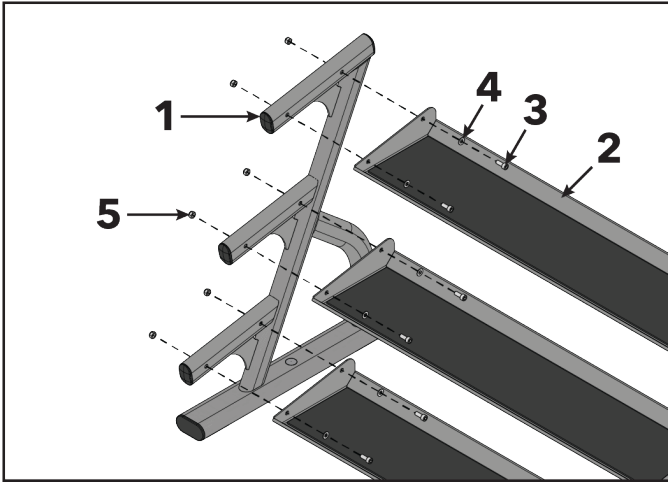

Item	Description	Qty.
1	Left Frame	1
2	Tray	3
3	M10 x 25mm Bolt	6
4	3/8" Flat Washer	6
5	M10 Hex Nylock Nut	6

2. Repeat step to install trays to the right frame.
3. Tighten to 20-29 ft-lbs (27-39 Nm).

## Assemble TL/TS

The following procedure applies to the LBR-TL and LBR-TS.

1. Remove hex bolts, washers and hex nuts securing the end saddles to the top tray.

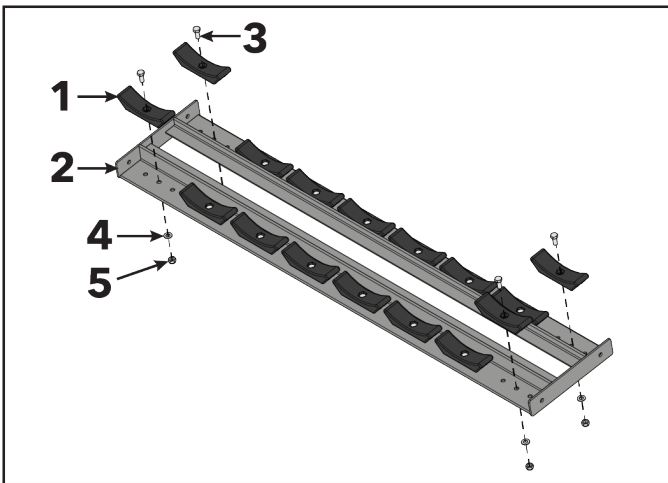

Item	Description	Qty.
1	Saddle	4
2	Top Tray	1
3	M10 x 25mm Hex Bolt	4
4	3/8" Flat Washer	8
5	M10 Hex Nylock Nut	4

- Loosely install bolts, washers and hex nuts securing the trays to the left frame.

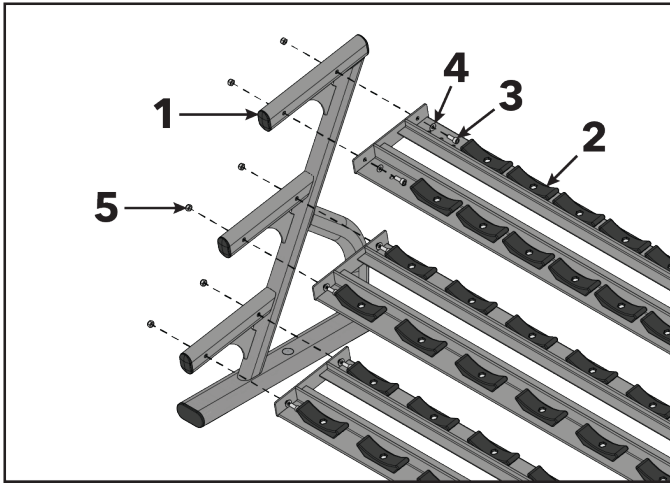

Item	Description	Qty.
1	Left Frame	1
2	Tray	3
3	M10 x 25mm Bolt	6
4	3/8" Flat Washer	6
5	M10 Hex Nylock Nut	6

- Repeat step to install trays to the right frame.
- Install hex bolts, washers and hex nuts securing saddles to top tray and **tighten to 20-29 ft-lbs (27-39 Nm)**.

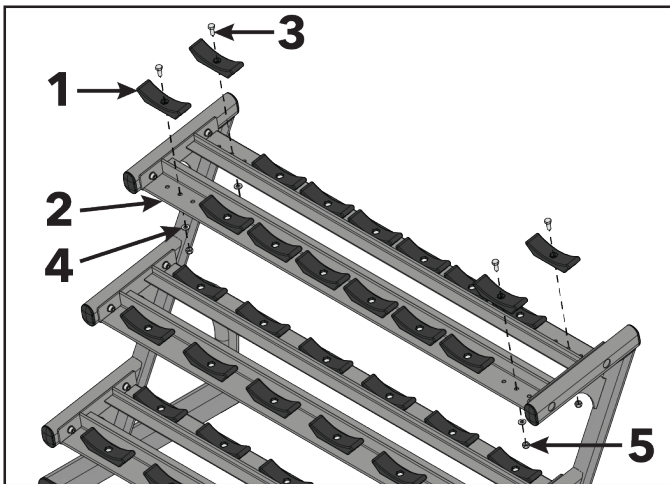

Item	Description	Qty.
1	Saddle	4
2	Top Tray	1
3	M10 x 25mm Hex Bolt	4
4	3/8" Flat Washer	4
5	M10 Hex Nylock Nut	4

- Tighten all loose hardware to 20-29 ft-lbs (27-39 Nm).

## Install Hole Plugs

The following procedure applies to the LBR-TF, LBR-TL, LBR-TR and LBR-TS.

Install hole plugs to frames using a rubber mallet.

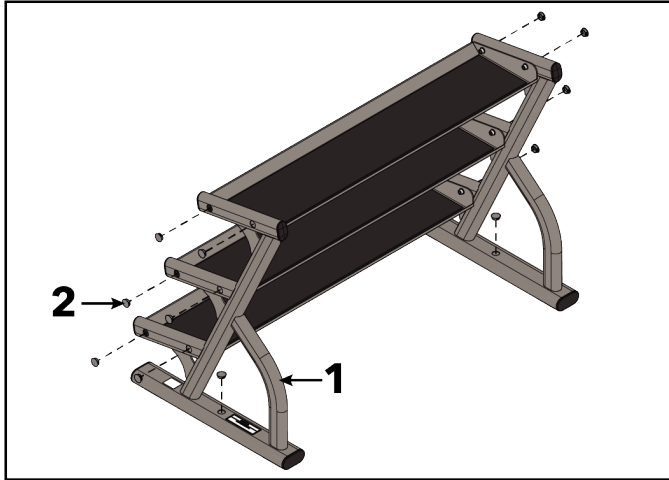

Item	Description	Qty.
1	Frame	2
2	Hole Plug	14

### 3. Product Information

#### Accessory Rack (LBR-TR)

Machine Weight:	168 lbs.	76 kg.
Size (L x W x H):	in. = 54 x 29 x 38	cm = 137 x 73 x 96
Live Area (L x W):	in. = 54 x 53	cm = 137 x 135
Storage Capacity:	270 lbs./tier	120 kg./tier

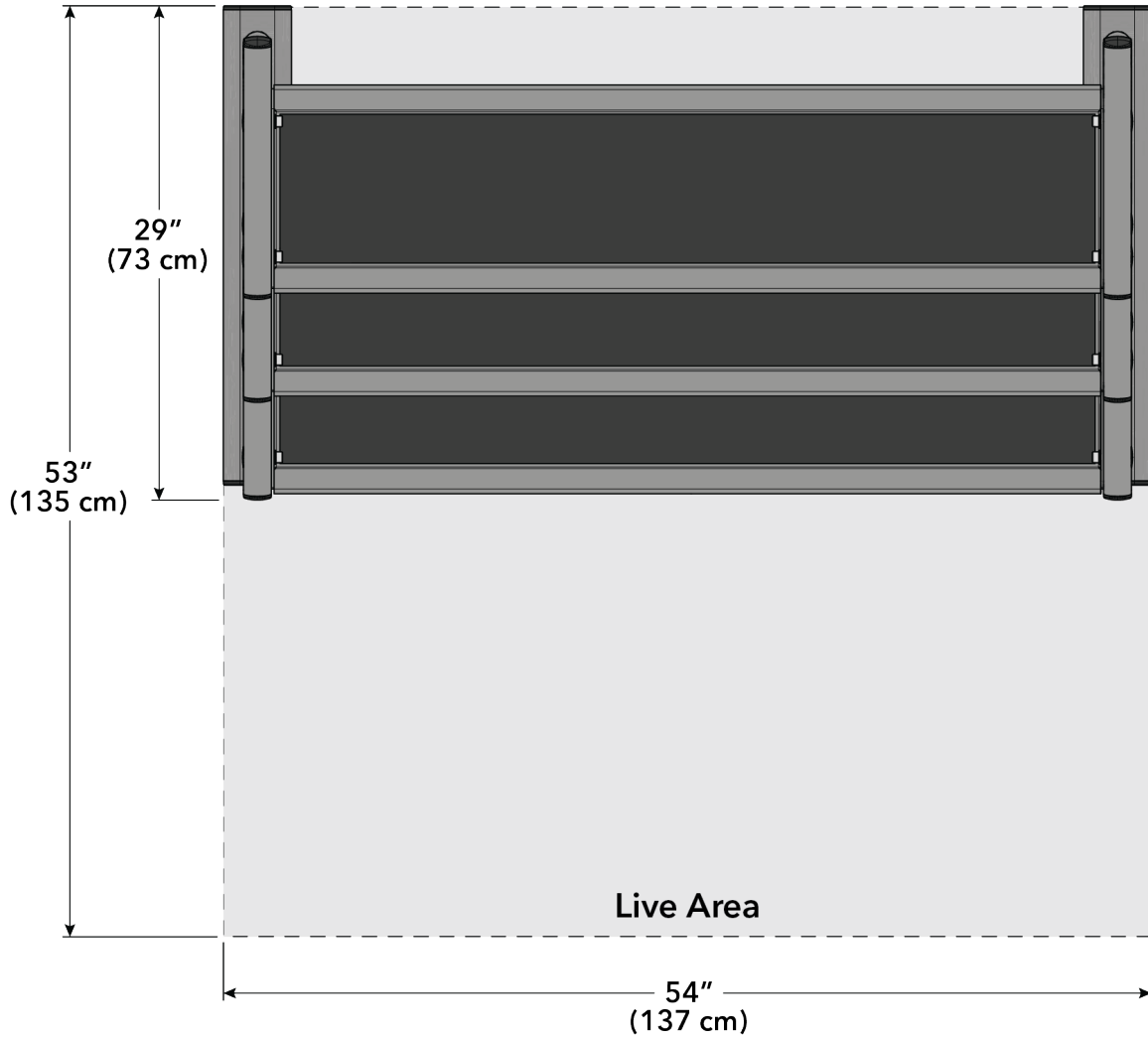

## Hex Dumbbell Rack (LBR-TF)

Machine Weight:	167 lbs.	76 kg.
Size (L x W x H):	in. = 54 x 29 x 38	cm = 137 x 73 x 96
Live Area (L x W):	in. = 54 x 53	cm = 137 x 135
Storage Capacity:	270 lbs./tier	120 kg./tier
Max Load:	1 set of 5 lb.-50 lb. hex dumbbells (550 lbs)	

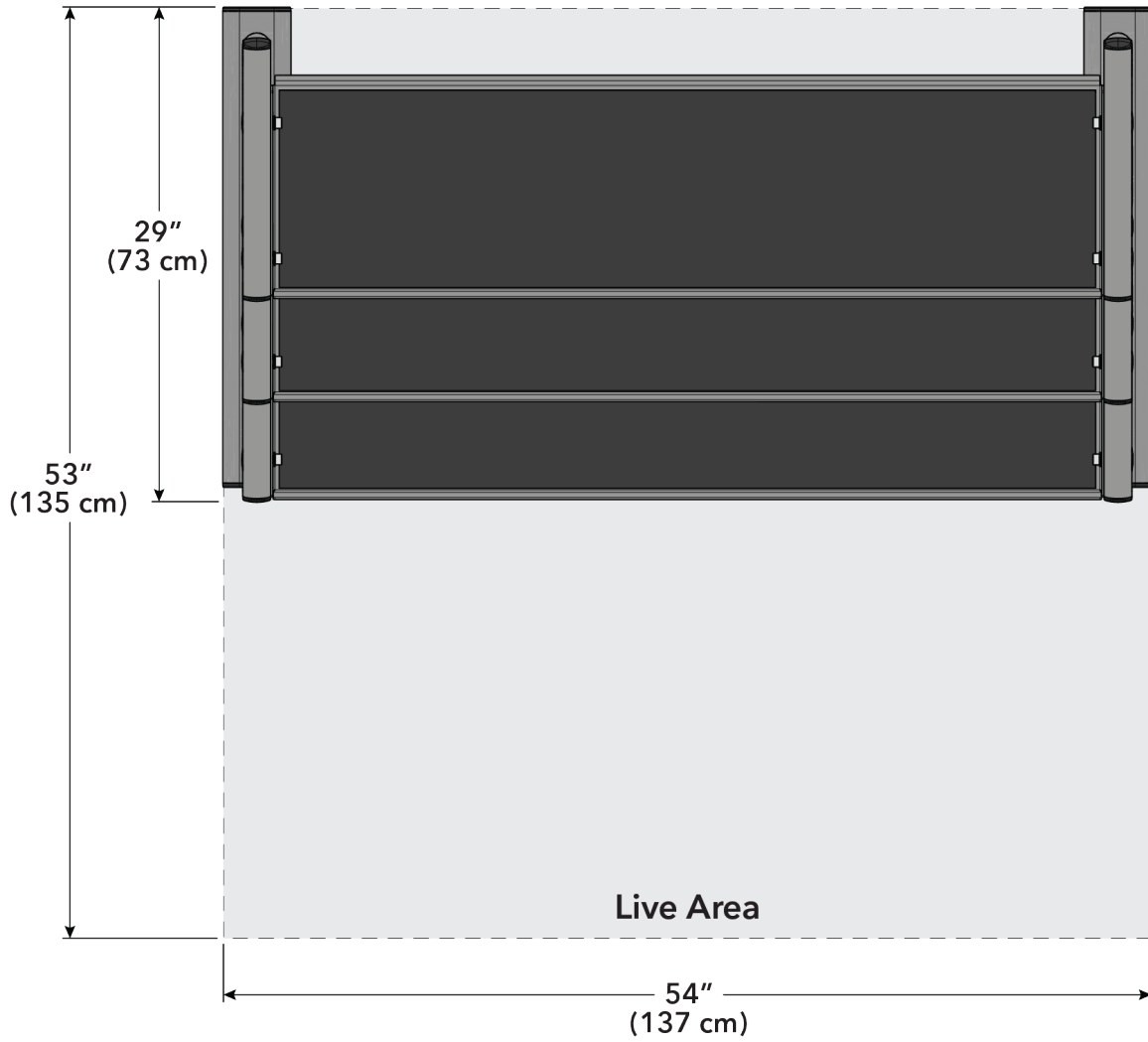

## Dumbbell Rack (LBR-TL)

<b>Machine Weight:</b>	286 lbs.	130 kg.
<b>Size (L x W x H):</b>	in. = 97 x 29 x 38	cm = 246 x 73 x 96
<b>Live Area (L x W):</b>	in. = 97 x 53	cm = 246 x 135
<b>Storage Capacity:</b>	650 lbs./tier	295 kg./tier
<b>Max Load:</b>	1 set of 5 lb.-75 lb. dumbbells (1,200 lbs)	

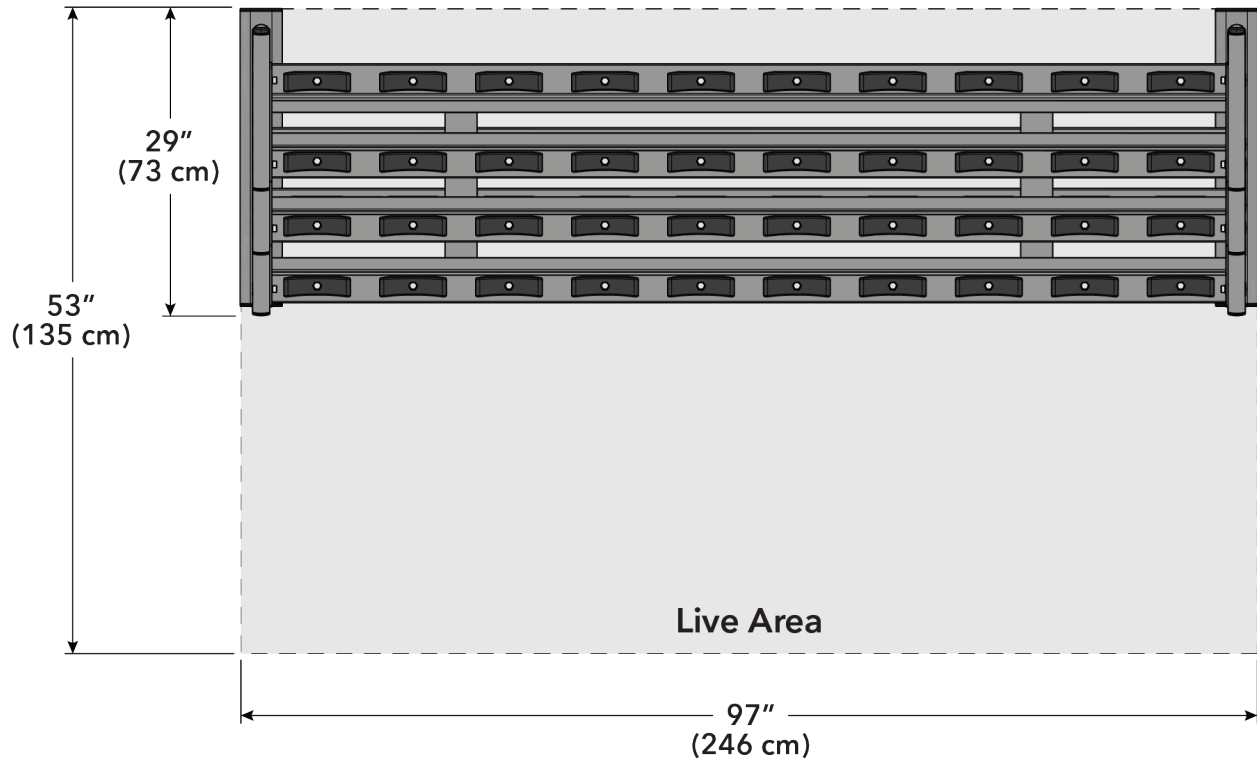

## Dumbbell Rack (LBR-TS)

<b>Machine Weight:</b>	200 lbs.	91 kg.
<b>Size (L x W x H):</b>	in. = 61 x 29 x 38	cm = 155 x 73 x 96
<b>Live Area (L x W):</b>	in. = 61 x 53	cm = 155 x 135
<b>Storage Capacity:</b>	270 lbs./tier	120 kg./tier
<b>Max Load:</b>	1 set of 5 lb.-50 lb. dumbbells (550 lbs)	

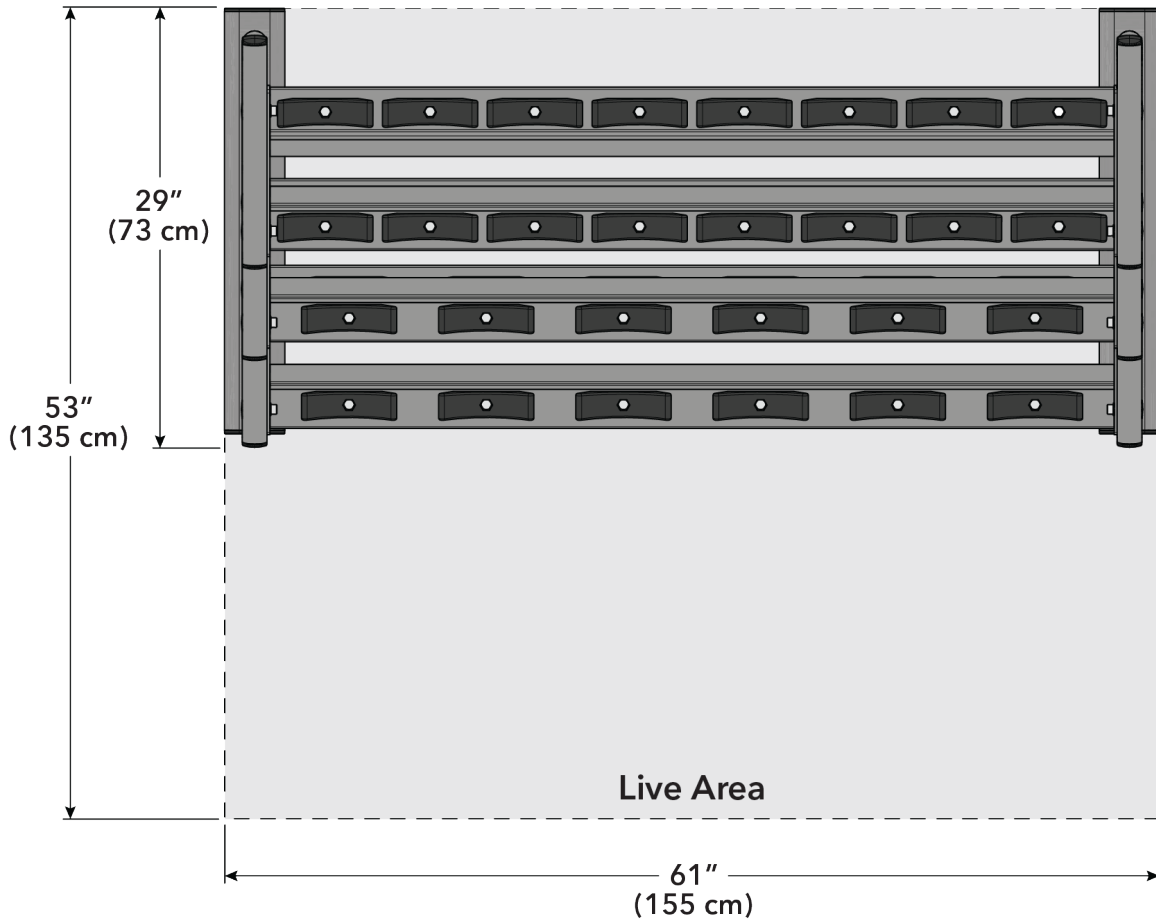

# 4. Maintenance Procedures

## Maintenance Schedule

ACTION	DAILY	WEEKLY	MONTHLY	AS NEEDED
<b>WAX</b>				
Frames				✓
<b>INSPECT</b>				
Frame		✓		
Hardware		✓		
Paint			✓	

### Wax

- Frames with a standard, non-abrasive, wax finish.

### Inspect

- Hardware. Check for loosening. Tighten as required.
- Frames. Inspect for wear and damage.
- For paint chips. Fill in immediately with manufacturers touch-up paint.

### Once a Week

- Visually inspect all hardware for loosening, tampering or wear.

### Once a Month

- Inspect hardware on all machines and tighten any bolts or nuts that may have loosened over the life of the product.

### Notes

- Use polishing compound (such as car wax) and remove shoe scuffs from powder coated surfaces as necessary.

### Approved and Compatible Cleaners

Two preferred cleaners have been approved by reliability experts: PureGreen 24 and Gym Wipes. Both cleaners will safely and effectively remove dirt, grime and sweat from equipment. PureGreen 24 and the Antibacterial Force formula of Gym Wipes are both disinfectants that are effective against MRSA and H1N1.

PureGreen 24 is available in a spray which is convenient to use. Apply the spray to a microfiber cloth and wipe down the equipment. Use PureGreen 24 on the equipment for at least 2 minutes for general disinfection purposes and at least 10 minutes for fungus and viral control.

Gym Wipes are large, durable pre-moistened wipes to use on the equipment before and after workouts. Use Gym Wipes on the equipment for at least 2 minutes for general disinfection purposes.

Contact Customer Support Services to order these cleaners (1-800-351-3737 or email: [customersupport@lifefitness.com](mailto:customersupport@lifefitness.com)).

Mild soap and water or a mild non-abrasive household cleaner can also be used to clean the display and all exterior surfaces. Use a soft microfiber cloth only. Apply the cleaner to the microfiber cloth before cleaning. DO NOT use ammonia or acid based cleaners. DO NOT use abrasive cleaners. DO NOT use paper towels. DO NOT apply cleaners directly to the equipment surfaces.

### Removal of Paint, Marking Pens, or Labels

- Butyl cellosolve works well for removal of paints, marking pen inks, lipstick, etc.
- Labels, stickers, etc. may be removed using kerosene. When the solvent will not penetrate sticker material, apply heat (hair dryer) to soften the adhesive and promote removal. GASOLINE SHOULD NOT BE USED.

# 5. Bolt to Floor Guide

## Introduction

Life Fitness designs its products to be stable when used as designed. Because strength training is dynamic, we cannot predict how users will ultimately use the products in all circumstances. Therefore, Life Fitness **recommends** that strength training equipment be secured to a solid, level surface to stabilize and eliminate rocking or tipping over.

Each new unit shipped comes with a multi-language hangtag stating the importance of bolting the unit down as a safety precaution.

It is the facility's responsibility to adhere to local and regional building codes.

## Delivery and Installation Tips

### All Anchors

- Fasteners must have minimum embedment in concrete floor, not including screed, regardless of wood/tile/rubber over sub-floor. (See *Anchor Types* for maximum sub-floor thickness between unit and concrete to equipment foot must be made of flooring or other material (i.e. no air gaps)).
- DO NOT reuse fasteners. Static and Dynamic anchors are designed for one-time use only.
- Factor in equipment's feet height when selecting fastener length.
- Factor in flooring thickness when selecting fastener length.
- It is also recommended to drill an additional 1/2" (12.7 mm) of depth beyond the length of the fastener being used to ensure that debris does not block the entry of the anchor.
- Minimum concrete compressive strength: 3000 psi (20 N/mm<sup>2</sup>).

### Anchoring

- All anchors must have a minimum embedment into concrete, regardless of wood/tile/rubber/screed over sub-floor.
- Dynamic anchors must have a minimum embedment depth in concrete to ensure maximum security and pull out force. See *Anchor Types* for embedment depth minimums.

### Building Codes

It is the facility's responsibility to adhere to local and regional building codes. Please verify with the customer to ensure that they are aware of this.

### Carpeting

If bolted down to carpet flooring, be sure to use a box cutter knife to cut the carpet threads around each foot. This will help avoid the carpet threads from being wrapped around and pulled by the drill bit.

### Competitor Product

The bolt down guidelines and procedures for Life Fitness products were determined by the company's Engineering and Installation Development groups. These guidelines include which anchors to use and positioning of the anchors are required for Life Fitness product.

- Life Fitness does not have that level of specification or engineering input for competitive product.
- Life Fitness installation teams are not permitted to anchor competitor equipment.

### Drilling

It is also recommended to drill an additional 1/2" (12.7 mm) of depth beyond the length of the fastener being used to ensure that debris does not block the entry of the anchor.

- This can be done by marking your drill bit with a piece of tape.
- While it is recommended that a vacuum be used to clean up debris, this will not account for all the debris that will settle at the bottom of the drilled hole.

### Anchor Type - Static

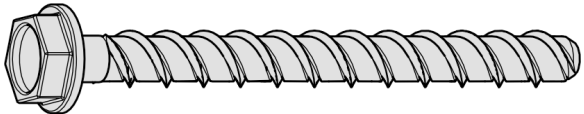
Static Anchor	Standard Sizes	Drill Bit Size
	Imperial: KH-EZ 3/8" x 5"	3/8in
	Metric: HUS-H 10mm x 130mm	10mm

## Anchor Specifications

Static Anchor	Minimum Concrete Thickness	Minimum Drill Depth in Concrete	Minimum Concrete Embedment	Minimum concrete compressive strength
KH-EZ 1/4"	4-1/8" (105mm)	1/2" (12.7mm) beyond anchor length	2-1/2" (63.5mm)	3000psi (20 N/mm <sup>2</sup> )
HUS-H 6mm	3-3/32" (100mm)	25/64" (10mm) beyond anchor length	2-1/64" (55mm)	3000psi (20 N/mm <sup>2</sup> )

## Pullout Force

Life Fitness specifies Hilti™ static and dynamic anchors. According to the anchor manufacturer, the recommended design pullout force (in tension) for the specified anchors, when properly installed in cracked concrete, is provided in the side table. This table should be used for reference only; for additional and up-to-date information on the anchor capabilities or the design pullout force in other substrates, please consult Hilti directly at <https://www.us.hilti.com>.

Selected Anchor	Design Resistance in Tension *
KH-EZ 1/4" x 4"	830 lb
HUS-H 6MM x 120MM	3.3 kN
KH-EZ 3/8" x 4"	1535 lb
KH-EZ 3/8" x 5"	1535 lb
HUS-H 8MM x 120MM	3.3 kN
HUS-H 8MM x 150MM	3.3 kN
HSL-3 and HSL4 M 8/40	2000 lb
HST M12 x 115/20	8 kN
HST M12 x 195/200	8 kN
KB-TZ 3/8" x 3-3/4"	1615 lb

\* Design strength extracted from the Hilti Anchor Fastening Technology Manual.

## Tools Required

**⚠ WARNING:** Adhere to manufacturer's equipment warnings and guidelines. Follow manufacturer's instructions for proper usage.

- 1" L-shape SDS rotary hammer
- (Imperial anchors) 3/8" diameter carbide drill bit
- (Metric anchors) 10mm diameter carbide drill bit
- Extension cord
- Floor scanner / rebar detector (optional)
- Hammer (Dynamic anchors only)
- Rotary tool
- Safety glasses
- Tape measure
- Torque wrench
- Vacuum (for debris)

## Static Anchor

- Floor scanner / rebar detector (optional)
- 1" L-shape SDS rotary hammer
- 1/4" x 12" / 6 mm x 305 mm carbide drill bit (for 1/4" (6mm) anchors)
- 3/8" x 12" / 8 mm x 305 mm carbide drill bit (for 3/8" (8mm) anchors)
- Safety glasses

- Extension cord
- Impact wrench
- Vacuum (for debris)

## Static Anchor Procedure

**⚠ CAUTION:** If it is possible that the length of your bolt will not provide the minimum requirement of 2.5" (63.5mm) of engagement, a longer anchor should be used.

1. Place unit into position to be mounted and cycle unit to set stance.
2. Each foot **must** get at least one static fastener.
3. Wearing protective glasses, drill down into the flooring to the required depth as perpendicular as possible, ensuring that the foot thickness is being accounted for; refer to *Anchor Selection* and *Foot Dimensions*.

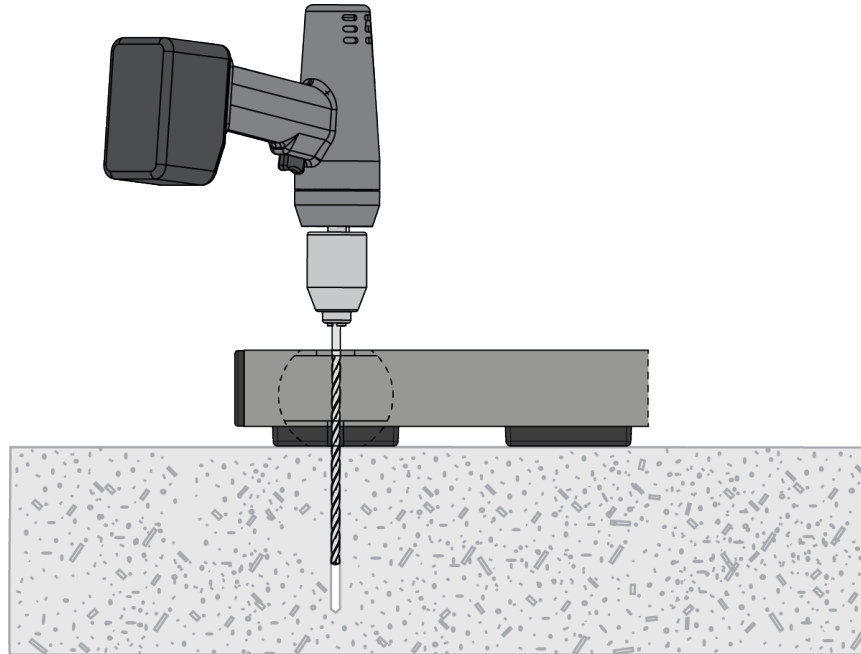

4. Insert fastener and tighten to 18 Foot-Pounds (24Nm) for 1/4" (6mm) anchor or 40 Foot-Pounds (54Nm) for 3/8" (8mm) anchor.

**NOTE:** If the legs/frame do not contact the mounting surface **DO NOT** pull down with the fastener or anchor. Loosen frame hardware and re-tighten to allow machine to align.

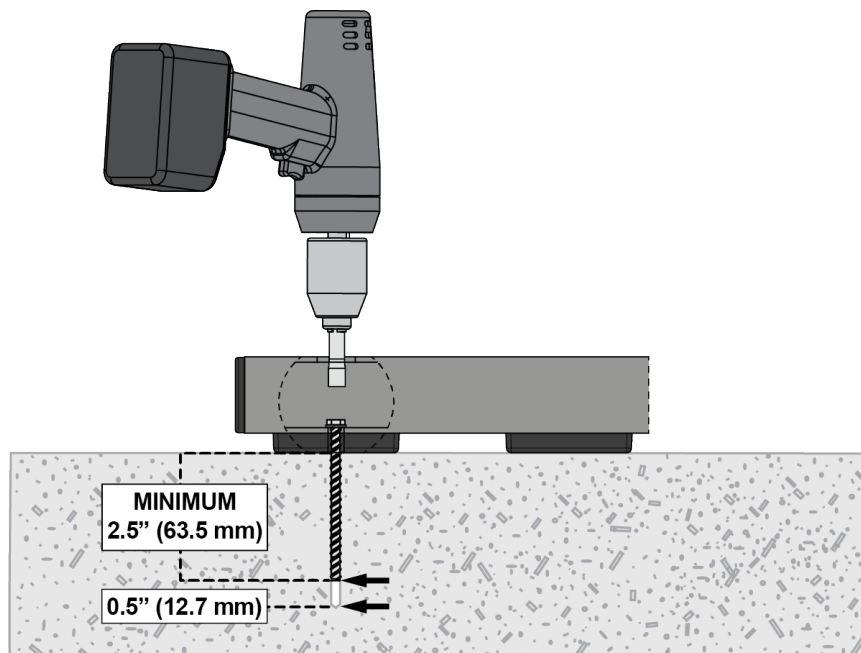

## Foot Dimensions

Use below image to determine foot specifications.

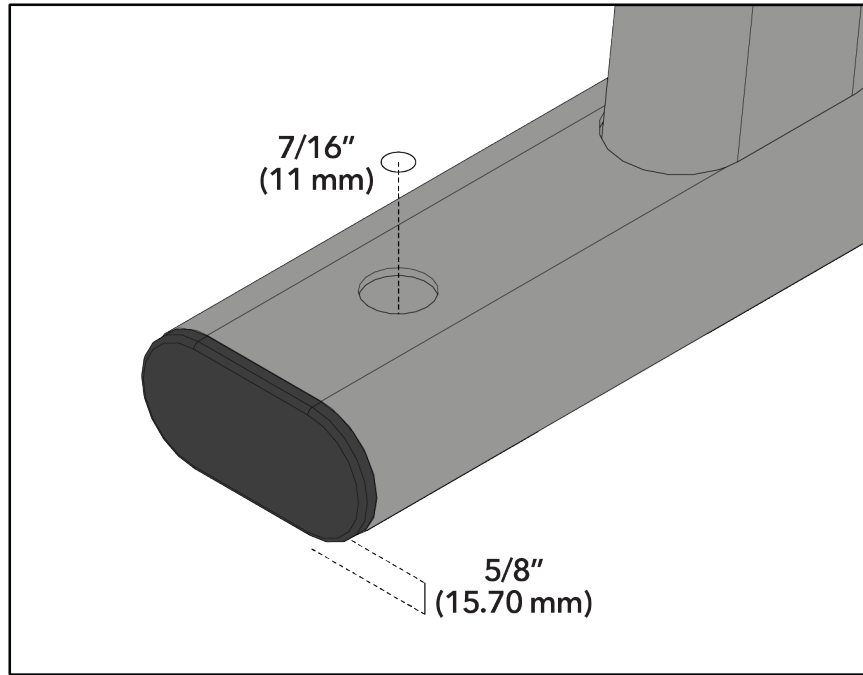





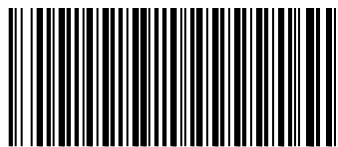

1030482-0001