

G2 GYM SYSTEM

ASSEMBLY INSTRUCTIONS

G2-002 / CLASS H / 03/17/25 / 8598201 REV CB

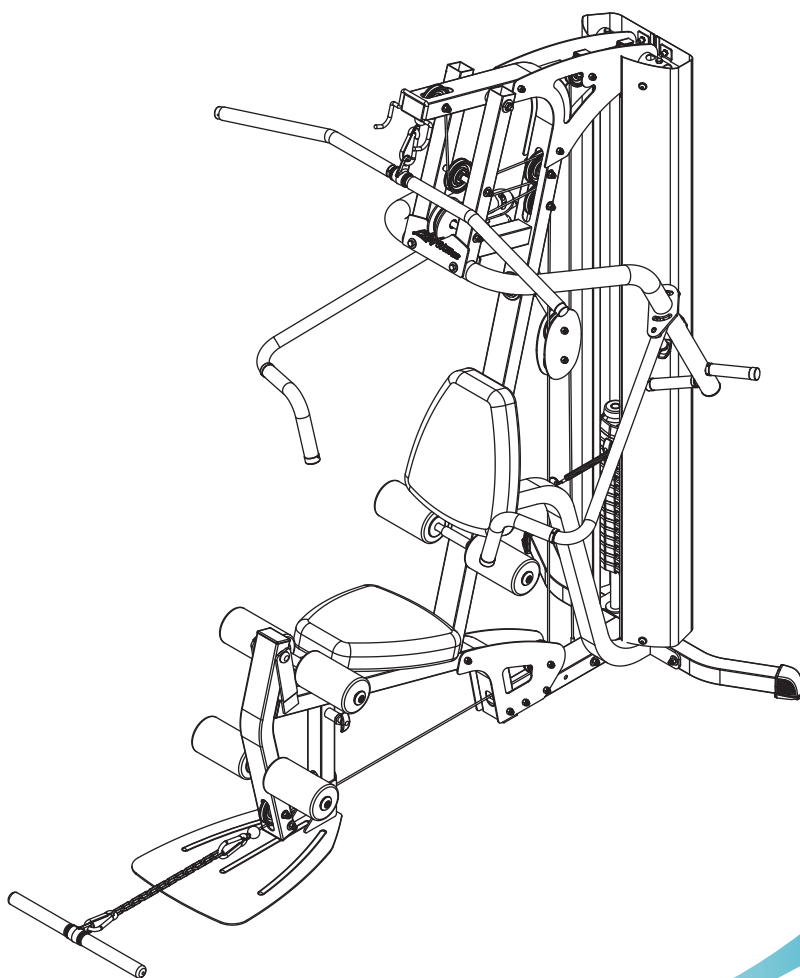

TABLE OF CONTENTS

Safety Statement	1
Important Notes	3
Tools Required for Assembly	3
Gym Layout	4
Parts List	5
Assembly Instructions	6
General Maintenance	24
Warranty Statement	25
Contact Information	26

IMPORTANT SAFETY INFORMATION

It is the sole responsibility of the purchaser of LIFE FITNESS products to read the owner's manual, warning labels and instruct all individuals, whether they are the end user or supervising personnel on proper usage of the equipment.

UNDERSTANDING EACH AND EVERY WARNING TO THE FULLEST IS IMPORTANT. IF ANY OF THESE INSTRUCTIONS OR WARNINGS ARE UNCLEAR, CONTACT LIFE FITNESS CUSTOMER SERVICE IMMEDIATELY AT **1-800-351-3737** WITHIN THE US AND CANADA. INTERNATIONAL OFFICE CONTACT INFORMATION IS AVAILABLE ON PAGE 26.

Keep children away from strength equipment. Parent or others supervising children must provide close supervision of children if the equipment is used in the presence of children.

This equipment is categorized as class H per EN 957-1. And as such this equipment is only intended for Home use. It is not intended for commercial, institutional and/or studio facilities use. Contact LIFE FITNESS with any questions regarding this classification.

It is recommended that all users of LIFE FITNESS exercise equipment be informed of the following information prior to use.



ACCESS CONTROL

LIFE FITNESS recommends that all fitness equipment be used in a supervised area. It is recommended that the equipment be located in an access controlled area. Control is the responsibility of the facility owner.



INSTALLATION

SECURING EQUIPMENT - LIFE FITNESS recommends that all equipment be secured to a solid, level surface to stabilize and eliminate rocking or tipping over. This must be performed by a licensed contractor.



PROPER USAGE

- 1 Do not use any equipment in any way other than as designed or intended by the manufacturer. It is imperative that LIFE FITNESS equipment is used properly to avoid injury.
- 2 Injuries may result if exercising improperly or excessively. It is recommended that all individuals consult a physician prior to commencing an exercise program. If at any time during exercise you feel faint, dizzy or experience pain, STOP EXERCIZING and consult your physician.
- 3 Keep body parts (hands, feet, hair, etc.), clothing and jewelry away from moving parts to avoid injury.
- 4 When adjusting any seat, knee hold down pad, range of motion limiter, foothold pad, pulley or any other type of adjuster, make certain that the adjusting pin is fully engaged in the hole to avoid injury.



INSPECTION

- 1 DO NOT use or permit use of any equipment that is damaged and or has worn or broken parts. For all LIFE FITNESS equipment use only replacement parts supplied by LIFE FITNESS.
2. Cables and Belts pose an extreme liability if used when frayed. Always replace any cable at first sign of wear (consult LIFE FITNESS if uncertain).
3. Routinely inspect all accessory clips that join attachments to the cables and replace at the first sign of wear.
4. MAINTAIN LABELS AND NAMEPLATES - Do not remove labels for any reason. They contain important information. If unreadable or missing, contact LIFE FITNESS for a replacement.
5. EQUIPMENT MAINTENANCE - Preventative maintenance is the key to smooth operating equipment as well as keeping your liability to a minimum. Equipment needs to be inspected at regular intervals.
6. Ensure that any person(s) making adjustments or performing maintenance or repair of any kind is qualified to do so. LIFE FITNESS will provide service and maintenance training at our corporate facility upon request or in the field if proper arrangements are made.
7. Before any use, examine all accessories approved for use with the LIFE FITNESS equipment for damage or wear.
8. DO NOT ATTEMPT TO USE OR REPAIR ANY ACCESSORY APPROVED FOR USE WITH THE LIFE FITNESS EQUIPMENT WHICH APPEARS TO BE DAMAGED OR WORN.



OPERATING WARNINGS

1. It is the purchaser's sole responsibility to properly instruct its end users and supervising personnel as to the proper operating procedures of all LIFE FITNESS equipment.
2. Keep children away from strength equipment. Parent or others supervising children must provide close supervision of children if the equipment is used in the presence of children.
3. Do not allow users to wear loose fitting clothing or jewelry while using equipment. It is also recommended to have user's secure long hair back and up to avoid contact with moving parts.
4. All bystanders must stay clear of all users, moving parts and attached accessories and components while machine is in operation.



SELECTORIZED WEIGHT STACK SYSTEMS

1. Use only weight selector pins supplied by LIFE FITNESS on weight stacks. Substitutes are forbidden.
2. Fully insert weight selector pins. Partial insertion can cause weights to fall unexpectedly.
3. Never pin the weight stack in an elevated position.
4. Never remove selector pin if any weights are suspended.
5. Never attempt to release jammed weights or parts.
6. Never use dumbbells or other means to incrementally increase the weight resistance. Use only those means provided by LIFE FITNESS.

Note: In our continuing effort to improve our products, specifications are subject to change.

©2008 Life Fitness, a division of Brunswick Corporation. All rights reserved.

www.lifefitness.com

IMPORTANT NOTES

Thank you for purchasing the Life Fitness G2 Gym System. Please read these instructions thoroughly and keep them for future reference.

This product must be assembled on a flat, level surface to assure its proper function. DO NOT securely tighten any frame connections until the entire frame has been assembled, unless otherwise stated.

TOOLS REQUIRED FOR ASSEMBLY

- Rubber mallet or hammer
- 3/4" wrench
- 9/16" wrench
- Ratchet with 3/4" and 9/16" sockets
- 5/32" Allen wrench
- Adjustable wrench
- Tape measure.

BOLT LENGTH RULER

Note: Bolt length is measured from the underside of the head of the bolt.

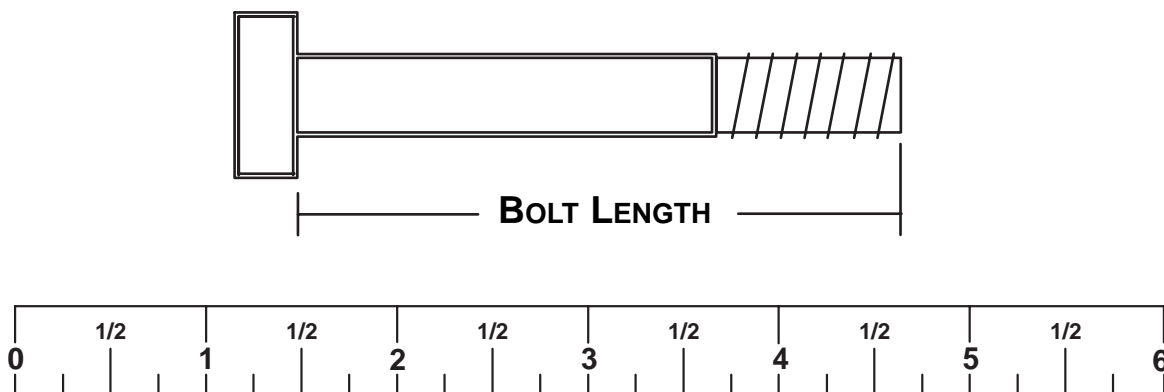

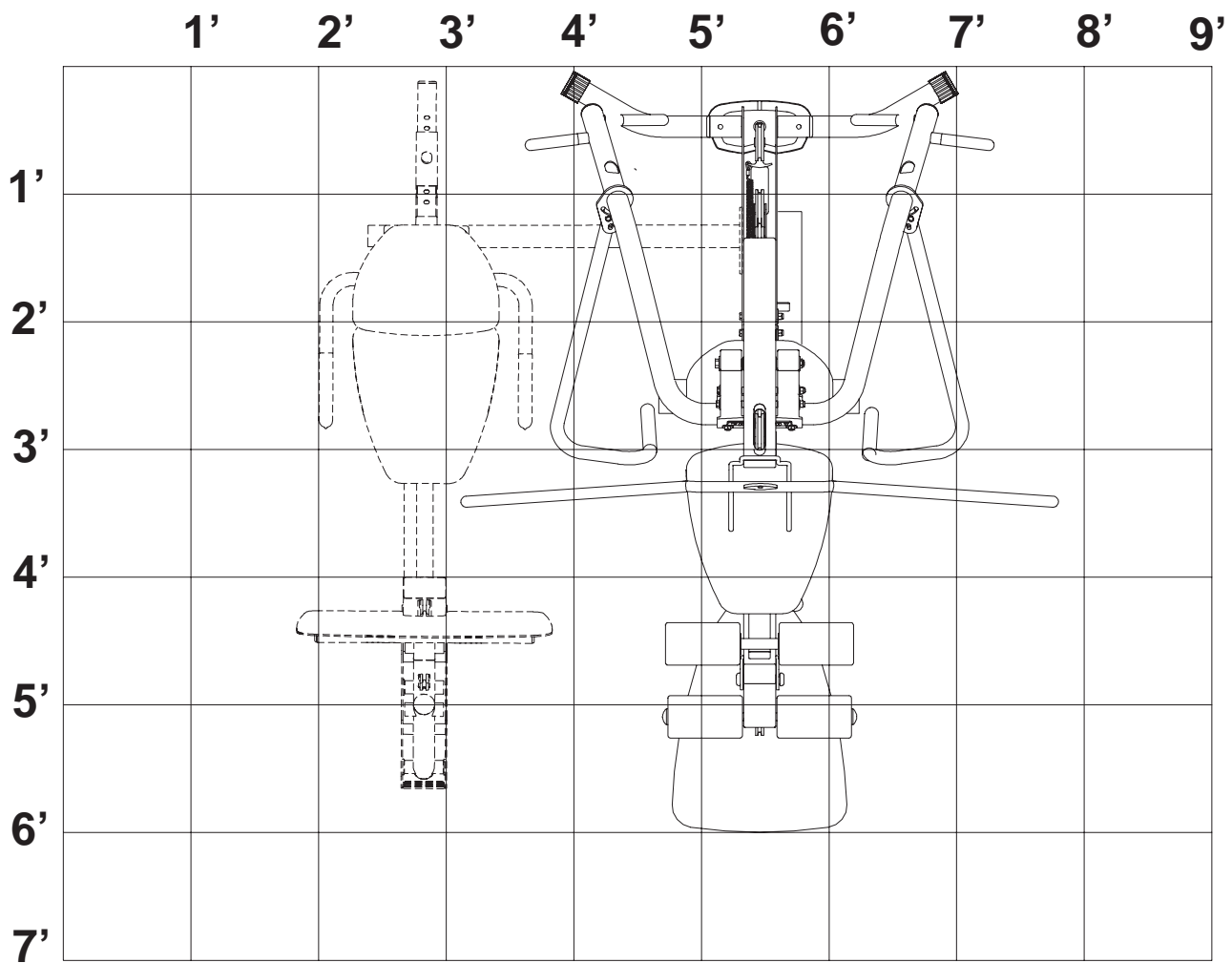

1 Square = 1' X 1'

Minimum Required Usable Space

Max User Weight = 300 pounds (136 kg)

Length = 82 inches (208.5 cm) 6' 10"

Width = 71 inches (180.5 cm) 5'11"

Height = 83 inches (211 cm) 6' 11"

Weight = 379 pounds (172 kg)

Dimensions Including GLP Leg Press (optional)

Length = 82 inches (208.5 cm) 6' 10"

Width = 108 inches (180.5 cm) 9' 0"

PARTS LIST

KEY	DESCRIPTION	QTY
1	FRAME	1
2	BASE	1
3	BASE PLATE	2
4	LEFT BOOM PLATE	1
5	RIGHT BOOM PLATE	1
6	RIGHT PRESS HANDLE	1
7	LEFT PRESS HANDLE	1
8	PRESS ARM	1
9	PRIMARY PIVOT	1
10	SEAT ADJUST	1
11	LEG PEDESTAL	1
12	PULLEY PLATE	2
13	SEAT PAD	1
14	3/4 X 17-3/8" TUBE	1
15	4 X 7" ROLLER PAD	6
16	72-3/8" GUIDE ROD	2
17	LAT BAR	1
18	3/4 X 18-1/8" TUBE	2
19	HEAD PLATE ASSY	1
20	LAT CABLE	1
21	LOW CABLE	1
22	WEIGHT PLATE	15
23	BACK PAD	1
24	3-1/2" PULLEY	12
25	ANKLE STRAP	1
26	CHAIN	1
27	3/8 X 1-3/4" BOLT	2
28	3/8 X 2-1/2" BOLT	1
29	3/8 X 3" SILVER BOLT	7
30	3/8 X 3-3/4" BOLT	14
31	3/8 X 8-3/4" BOLT	2
32	1/2 X 104mm BOLT	1
33	1/2 X 8-3/4" BOLT	1
34	3/8" LOCK NUT	26
35	1/2" LOW HT LOCK NUT	1
36	3/8" FLAT WASHER	20
37	1/2" FLAT WASHER	2

KEY	DESCRIPTION	QTY
38	3-1/2" CABLE GUARD	2
39	3/4" PLASTIC WASHER	12
40	3/4 X 4" SHAFT	1
41	3/8 X 3/4" FLANGE SPACER	2
42	3/8 X 1-1/16" FLANGE SPACER	8
43	3/8 X 1" LG SPACER	4
44	3/8 X 1-3/8" LG SPACER	2
45	WEIGHT STACK SPACER	2
46	WEIGHT STACK CUSHION	2
47	5/16 X 2" ROLL PIN	4
48	SHAFT COLLAR	2
49	3/8" LOCKING SPRING PIN	2
50	T-HANDLE SPRING PIN	1
51	WEIGHT SELECTOR PIN	1
52	3/8" STAR KNOB	1
53	ADJUSTABLE GLIDE	1
54	3/8" BLACK LOCK NUT	2
55	RH CAP	2
56	1/2" RHCAP HOLDER WASHER	2
57	SNAP LINK	3
58	LOW ROW BAR	1
60	1/2" LOCK NUT	1
61	WEIGHT STACK LABEL	1
62	FOOTPLATE	1
63	3/8 X 4" BOLT	2
64	FRAME BRACE	1
65	PRESS ARM SPACER	4
66	OVAL END CAP	2
67	ROLLER PAD CAP	6
68	5/16 X 1" BTN HEAD BOLT	6
69	SPACER PULLEY GUARD	2
70	3/8 X 3" BLACK BOLT	2
71	EXERCISE CARD	1
72	TOUCH-UP PAINT (SHADOW GRAY)	1
73	TOUCH-UP PAINT (PLATINUM)	1
74	SILICON	1
75	END CAP, 1-1/4	2

Note: Some of the parts listed may be pre-installed.



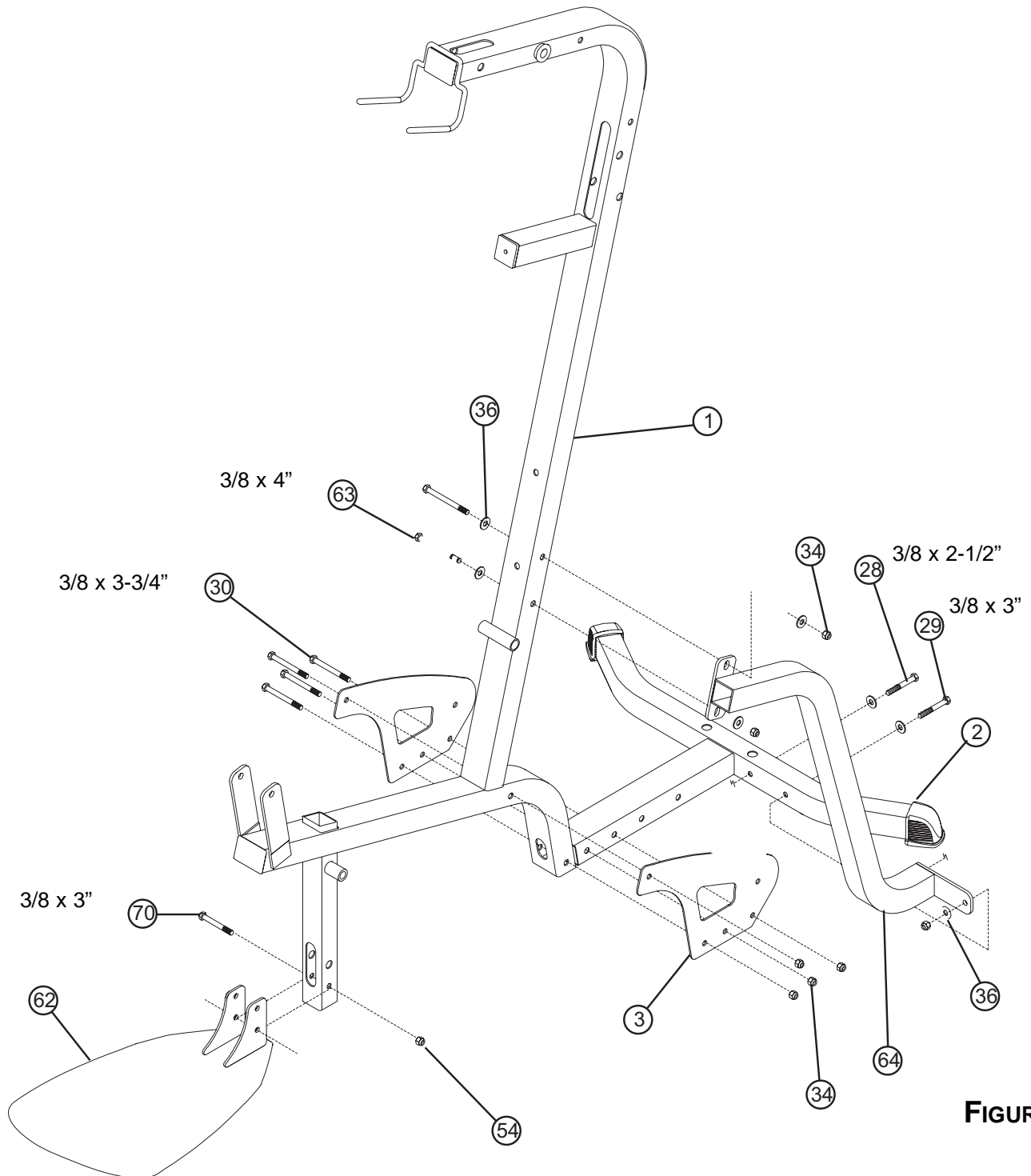

FIGURE 1

STEP 1:

- **LOOSELY** assemble two **BASE PLATES (3)** to the **FRAME (1)** and **BASE (2)** using four **3/8 X 3-3/4" BOLTS (30)** and four **3/8" LOCK NUTS (34)**. See **FIGURE 1**.
- **LOOSELY** assemble the **FOOTPLATE (62)** to the lower holes in the **FRAME (1)** using one **3/8 x 3" BLACK BOLT (70)** and one **3/8" BLACK LOCK NUT (54)**.
- **LOOSELY** assemble the **TOP** of the **FRAME BRACE (64)** to the **FRAME (1)** using two **3/8 x 4" BOLTS (63)**, two **3/8" WASHERS (36)** and two **3/8" LOCK NUTS (34)**. Assemble the **BOTTOM** of the **FRAME BRACE (64)** to the **BASE (2)** using one **3/8 x 3" BLACK BOLT (29)**, one **3/8 x 2-1/2" BOLT (28)**, three **3/8" WASHERS (36)** and one **3/8" LOCK NUT (34)**.

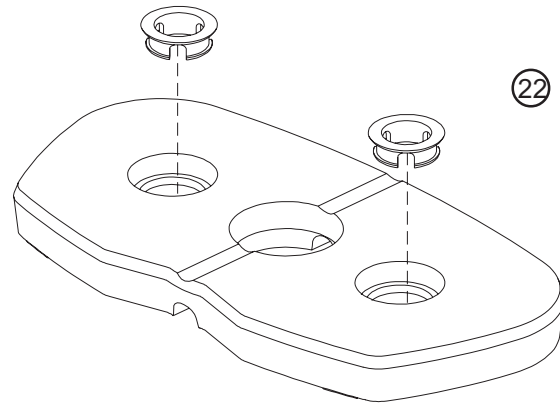

FIGURE 2

**CHECK THAT THE HEADPLATE (19) AND WEIGHT PLATES (22)
ARE ASSEMBLED AS SHOWN IN FIGURES 2 & 3.**

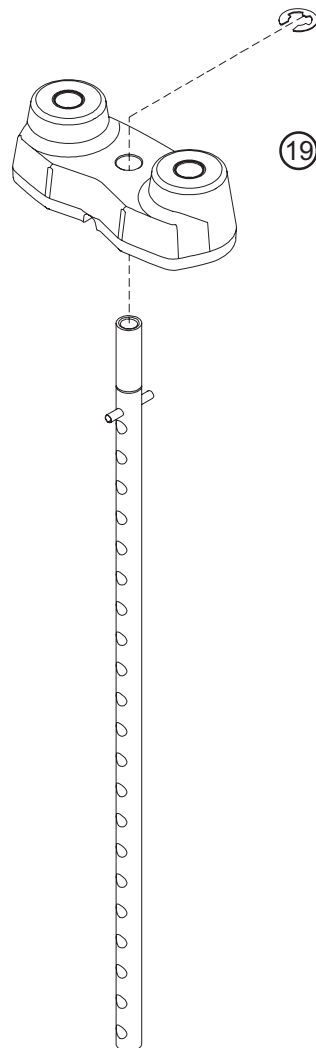

FIGURE 3



STEP 4:

- Place the two GUIDE RODS (16) through the BOTTOM SHROUD BRACKET (A) (FOUND IN THE SHROUD KIT BOX) into the BASE (2), as shown in FIGURE 4.

Note: Lubricate the GUIDE RODS (16) with the included silicon package.

- Slide the following items in order down each GUIDE ROD (16), one WEIGHT STACK SPACER (45), and one WEIGHT STACK CUSHION (46).
- Using **EXTREME CARE** slide all fifteen WEIGHT PLATES (22) down the GUIDE RODS (16) onto the WEIGHT STACK CUSHIONS (46). Make sure that the keyholes of the WEIGHT PLATES (22) are all facing the right way.
- Slide the HEAD PLATE ASSEMBLY (19) down the GUIDE RODS (16) onto the weight stack.
- Slide the SHAFT COLLARS (48) down each GUIDE ROD (16).

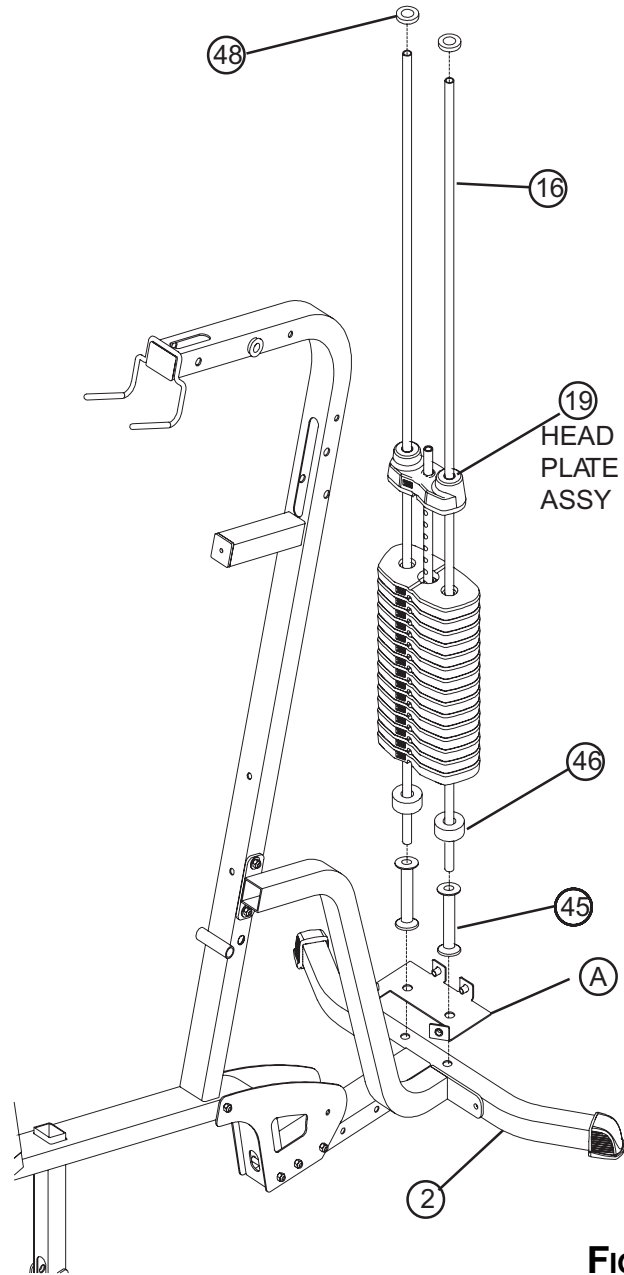

FIGURE 4

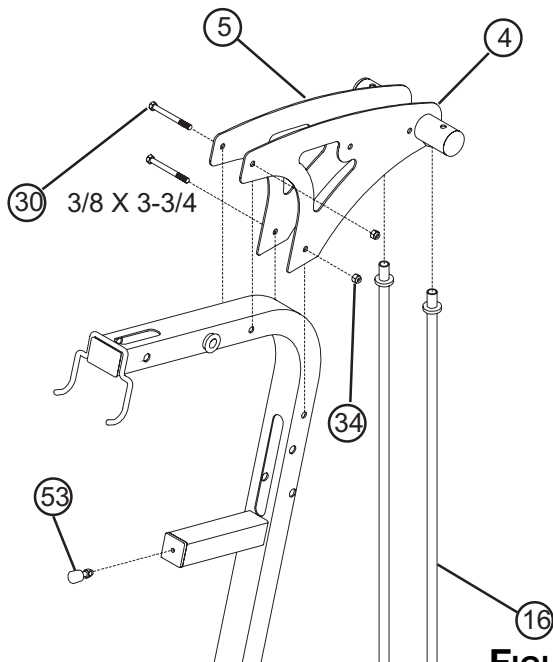

FIGURE 5

50 Pound Add-On Kit

Add:

- 5 - Weight Plates: Part No. ACUWT-PLATE
- 10 - Socket Bushings: Part No. 6224501
- 1 - Weight Stack Label: Part No. 7308601

Remove:

- 2 - Weight Stack Spacers: Item 45

Note: No cable change



STEP 5:

- Carefully slide the RIGHT and LEFT (5 & 4) BOOM PLATES onto the GUIDE RODS (16) as shown in FIGURE 5 and loosely assembly the BOOM PLATES (5 & 4) to the FRAME (1) using two 3/8 x 3-3/4" BOLTS (30) and two 3/8" LOCK NUTS (34). **CAUTION MUST BE TAKEN NOT TO PULL THE GUIDE RODS (16) OUT OF THE BASE (2).**
- Screw the ADJUSTABLE GLIDE (53) approximately 1/2" into the FRAME (1) and tighten the jam nut securely as shown.

STEP 6:

- Use a hammer to tap one 5/16 X 2" ROLL PIN (47) thru the LEFT PRESS HANDLE (7) until it is flush with the other side of the HANDLE as shown in FIGURE 6.
- Place END CAP 1-1/4" into end of PRESS HANDLE, as shown in Figure 6.
- Repeat STEP 6 for the RIGHT PRESS HANDLE (6).

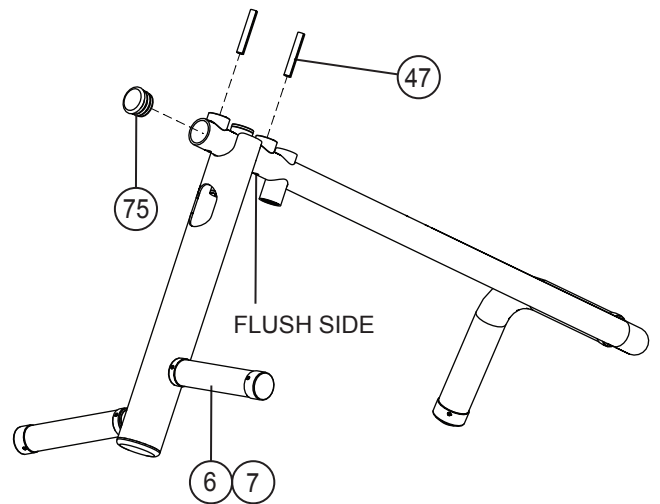

FIGURE 6

STEP 7:

- Place the LEFT PRESS HANDLE (7) onto the PRESS ARM (8). Place two PRESS ARM SPACERS (65) as shown over the 5/16 x 2" ROLL PINS (47), make sure that the 5/16 X 2" ROLL PINS (47) passes into the slots located in the plate of the PRESS ARM (8).
- Once in place, secure and tighten the LEFT PRESS HANDLE (7) to the PRESS ARM (8) using one 3/8" WASH-ER (36) and one 3/8" LOCK NUT (34).
- **IMPORTANT!** Do not overtighten: PRESS ARM should rotate freely.
- Repeat STEP 7 for the RIGHT PRESS HANDLE (6).

Note: Place the PRESS ARM (8) upside down on the floor as shown to complete this step. **HANDLES (7) MUST BE PLACED TOWARDS INSIDE OF THE PRESS ARM.**

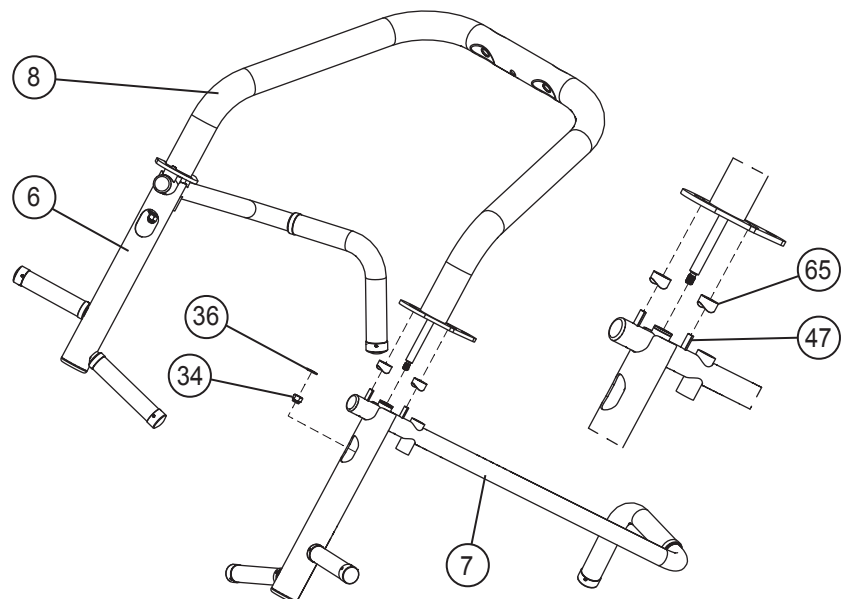
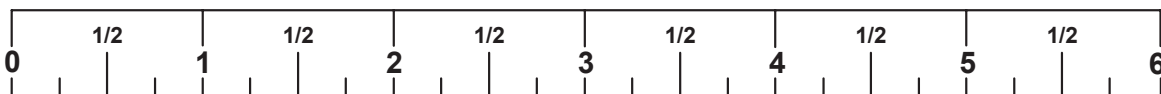

FIGURE 7



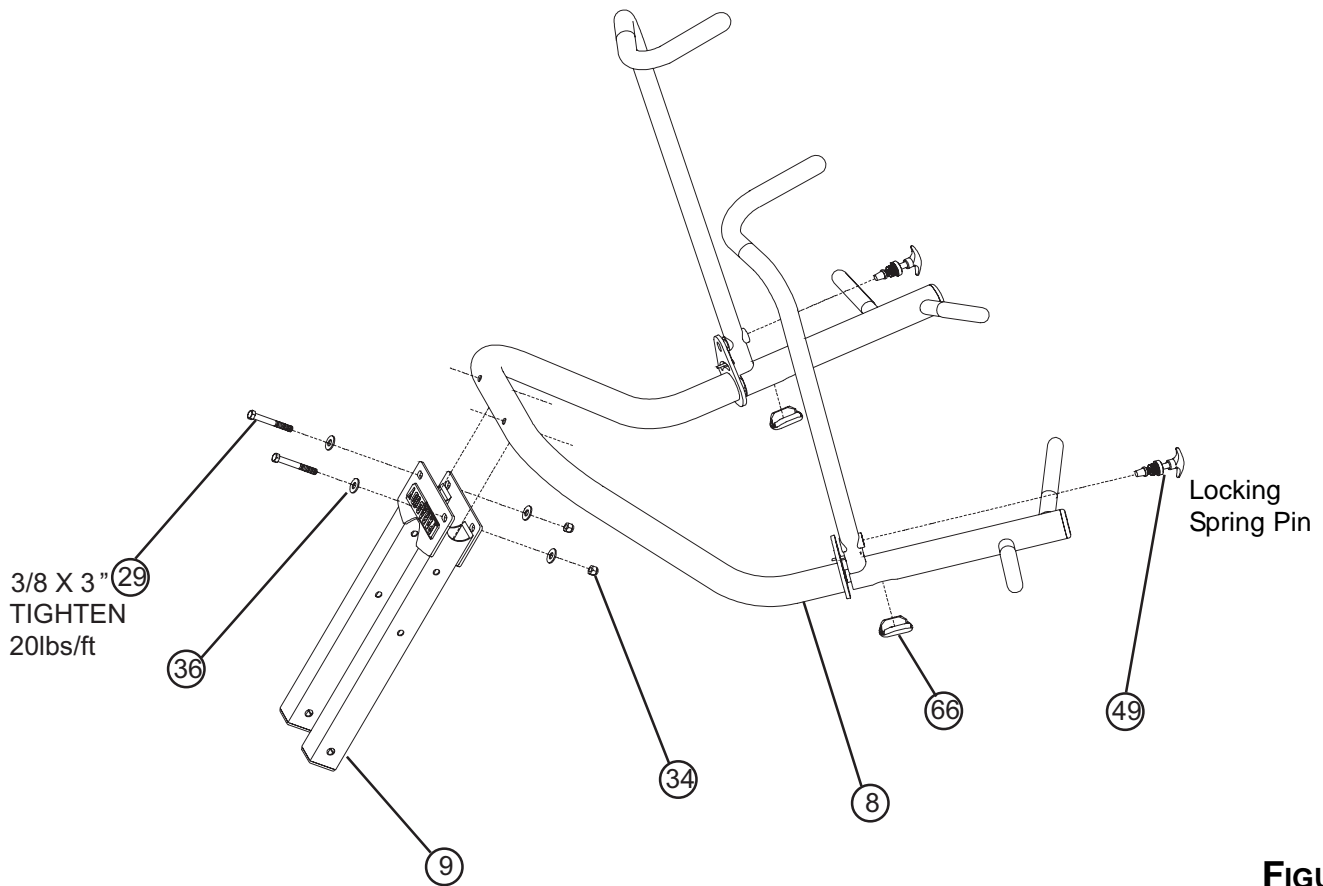

FIGURE 8

STEP 8:

- Place the PRESS ARM (8) into the PRIMARY PIVOT (9) and securely tighten using two 3/8 X 3" SILVER BOLTS (29), four 3/8" FLAT WASHERS (36), and two 3/8" LOCK NUTS (34).
- Insert and tighten two 3/8" LOCKING SPRING PINS (49) into the PRESS HANDLES (6 & 7).
- Lock the PRESS HANDLES (6 & 7) into place using the 3/8" LOCKING SPRING PINS (49).
- Insert one OVAL END CAP (66) into the opening of each handle as shown in FIGURE 8.
- To disengage the LOCKING SPRING PINS (49), pull out and twist 1/4 turn.

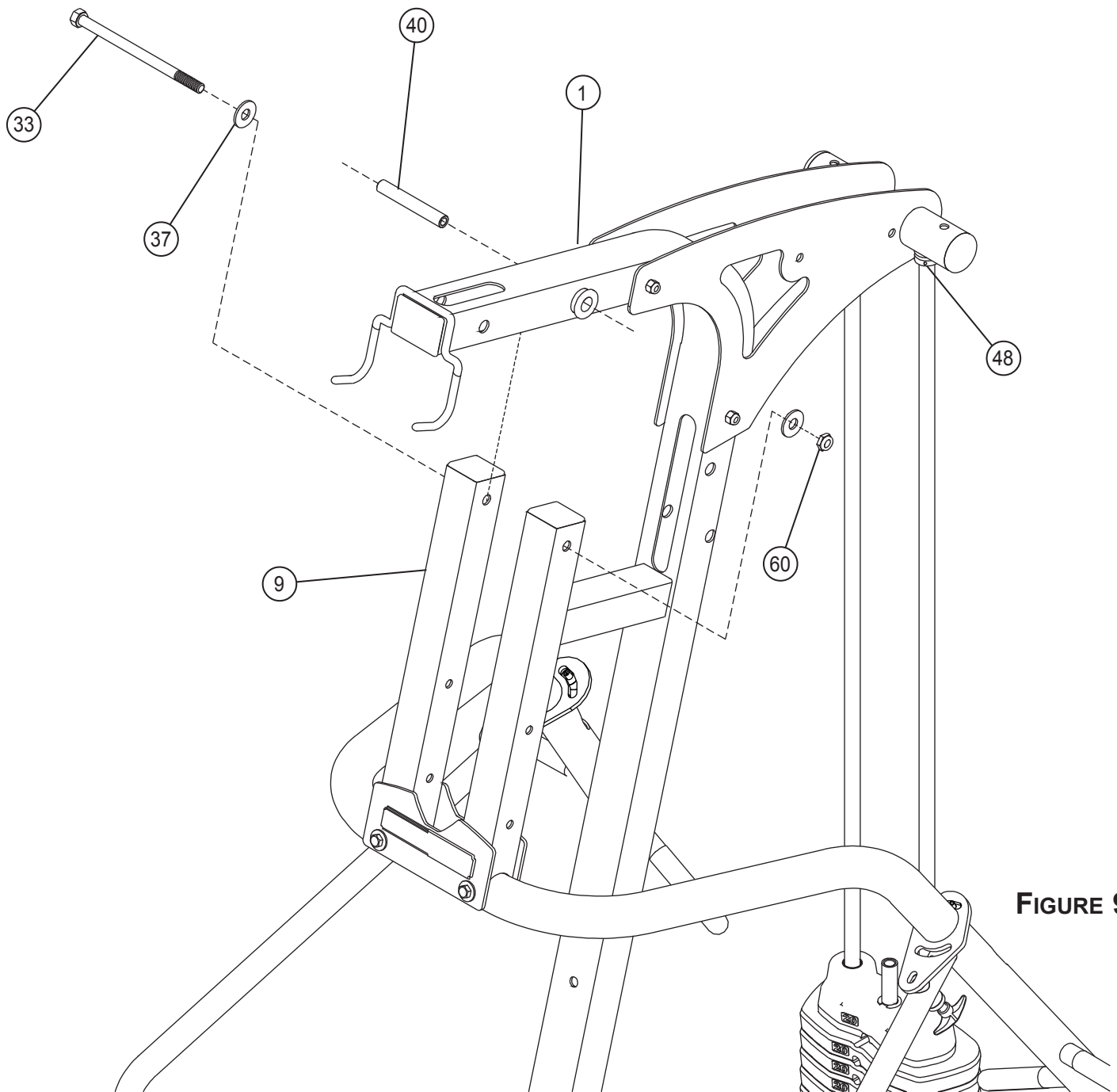
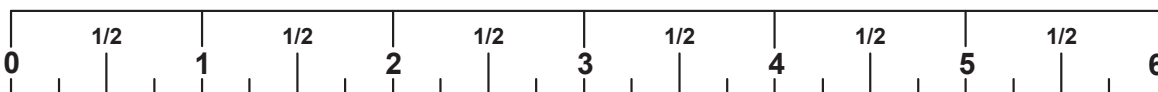

FIGURE 9

STEP 9:

- **SECURELY TIGHTEN ALL FRAME CONNECTIONS BEFORE PROCEEDING TO NEXT STEP.**
- **SECURELY TIGHTEN** the top of both SHAFT COLLARS (48) flush to bottom of both BOOM PLATES (4 & 5).
- Insert one 3/4 x 4" SHAFT (40) into both 3/4" flange bearings on the FRAME (1).
- Assemble the PRIMARY PIVOT (9) of the PRESS ARM ASSEMBLY to the top of the FRAME (1) using one 1/2 X 8-3/4" BOLT (33), two 1/2" FLAT WASHERS (37), and one 1/2" LOCK NUT (60).



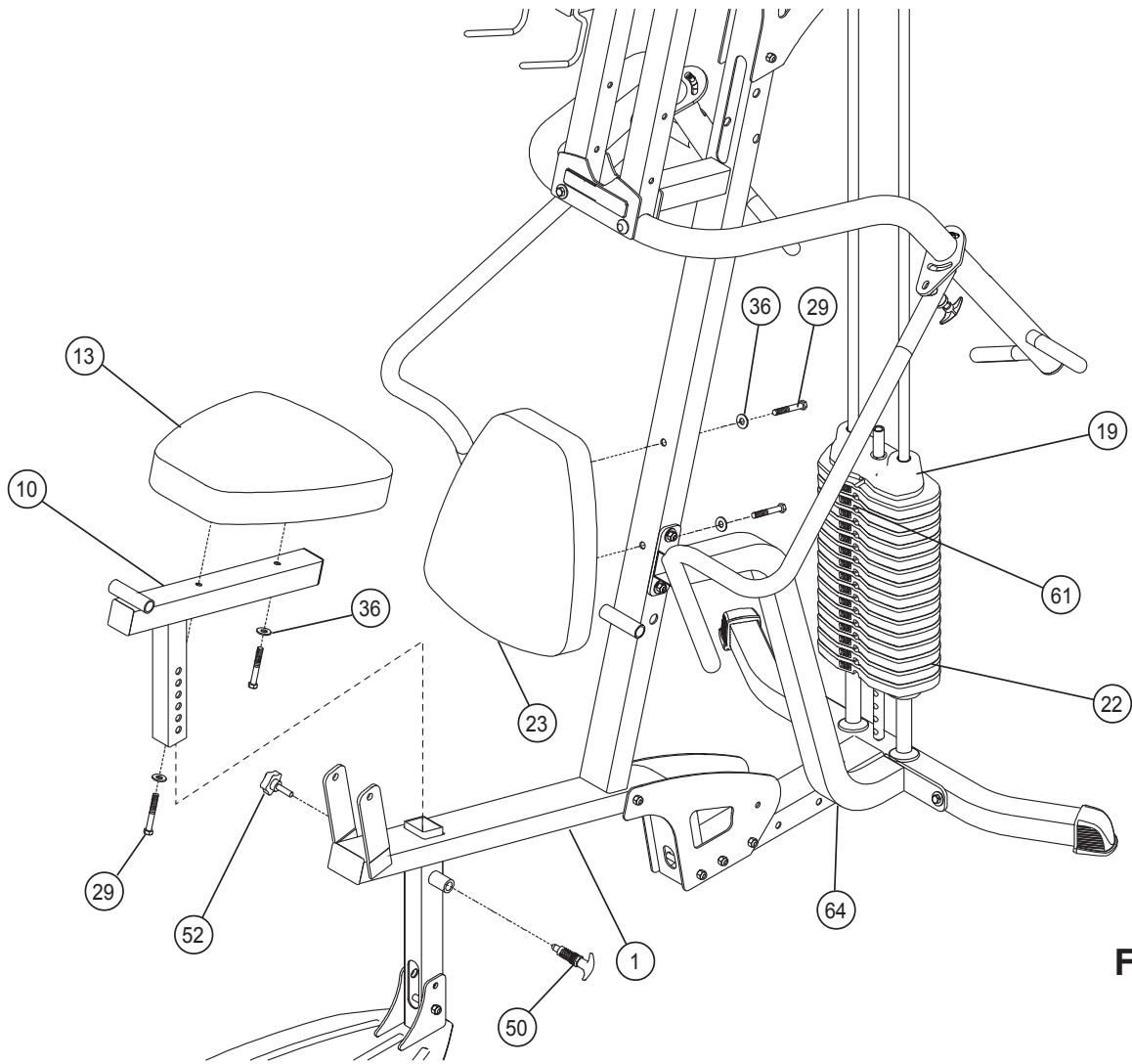

FIGURE 10

STEP 10:

- Apply the WEIGHT STACK LABELS (61) to the WEIGHT PLATES (22) and HEAD PLATE (19) as shown in FIGURE 10. Begin with number one at the HEAD PLATE (19) with the larger numbers in consecutive order towards the bottom of the weight stack.
- Securely assemble one SEAT PAD (13) to the SEAT ADJUST (10) using two 3/8 X 3" SILVER BOLTS (29) and two 3/8" WASHERS (36) as shown.
- Securely assemble one BACK PAD (23) to the FRAME (1) using two 3/8 X 3" SILVER BOLTS (29) and two 3/8" WASHERS (36) as shown. The top connection of the FRAME BRACE (64) may have to be loosened and then re-tightened after the BACK PAD (23) is tightened.
- Gently insert the SEAT ADJUST (10) into the tube located on the FRAME (1).
- Securely tighten the T-HANDLE SPRING PIN (50) to the FRAME (1) and hand tighten the 3/8" STAR KNOB (52).

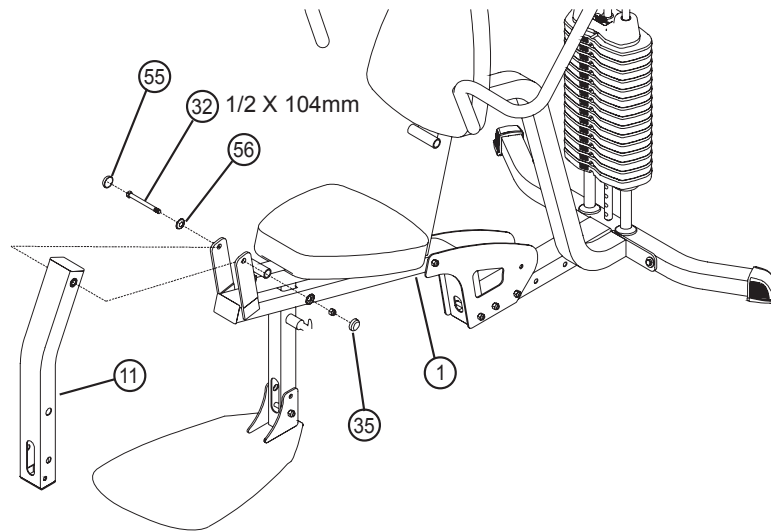
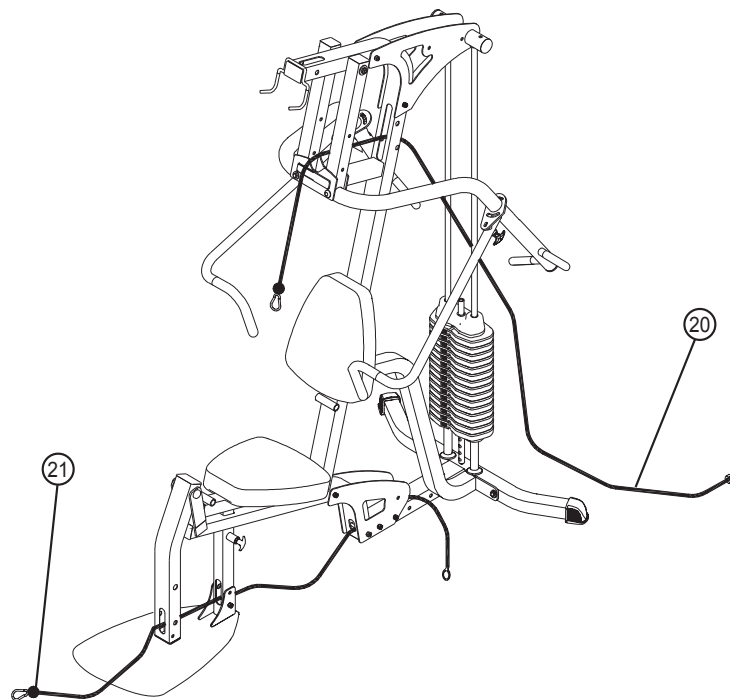

FIGURE 11

STEP 11:

- Assemble the LEG PEDESTAL (11) to the FRAME (1) using one 1/2 X 104mm BOLT (32), two 1/2" RHCAP HOLDER WASHERS (56) and one 1/2" LOW HT LOCK NUT (35).
- Assemble two RH CAPS (55) to the 1/2" RHCAP HOLDER WASHERS (56) as shown in FIGURE 11.



STEP 12:

- Route the LAT CABLE (20) and LOW CABLE (21) as shown in FIGURE 12.

FIGURE 12

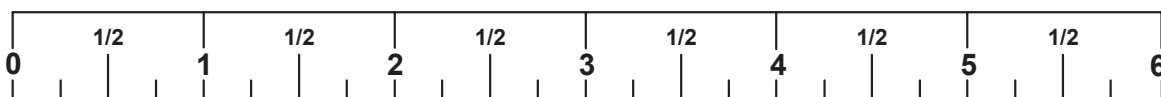
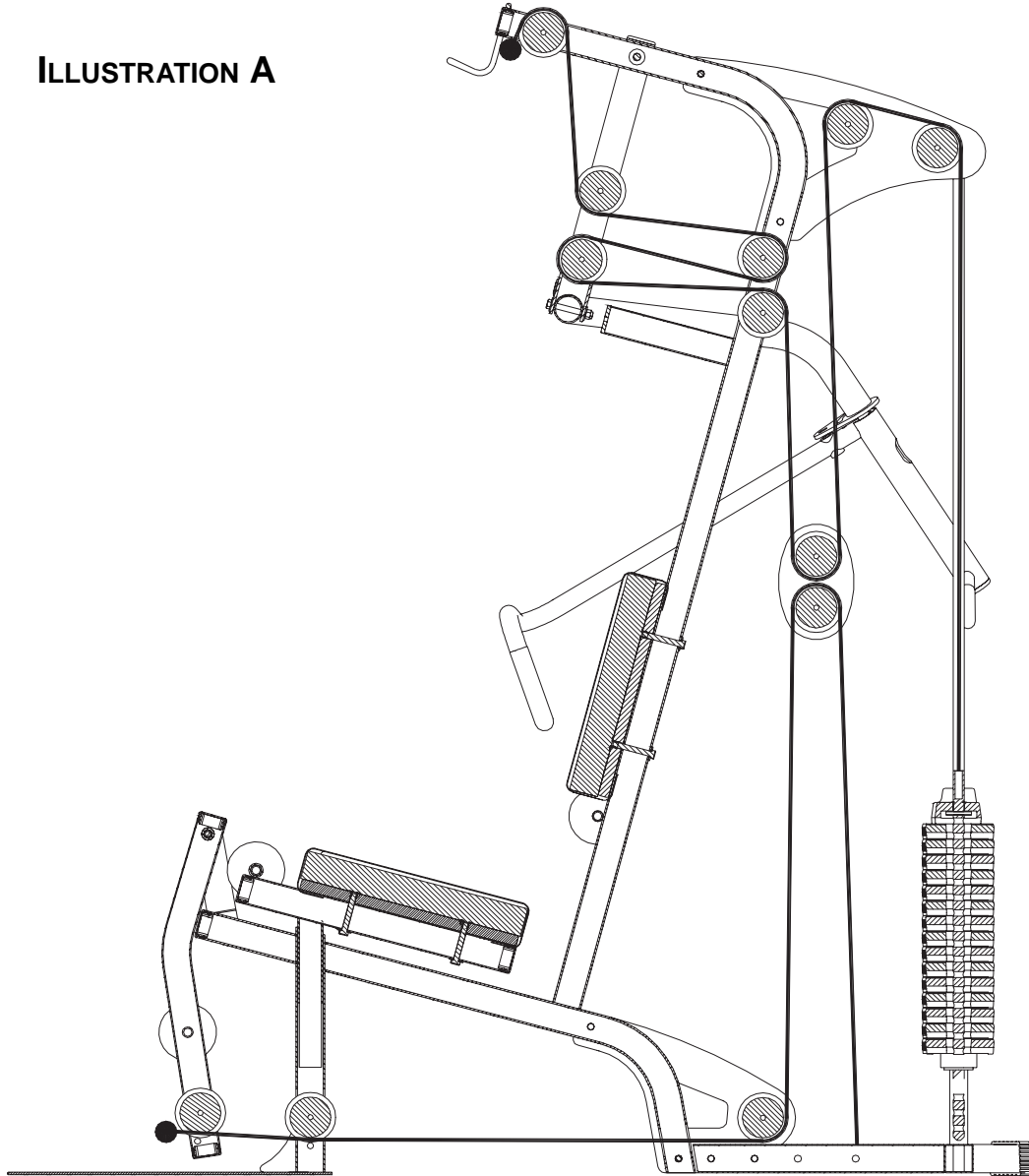

ILLUSTRATION A



- ILLUSTRATION “A” used as the cable routing reference for steps 13-16.

Note: If you purchased a leg press, please refer to the cable routing instructions included with the leg press kit.

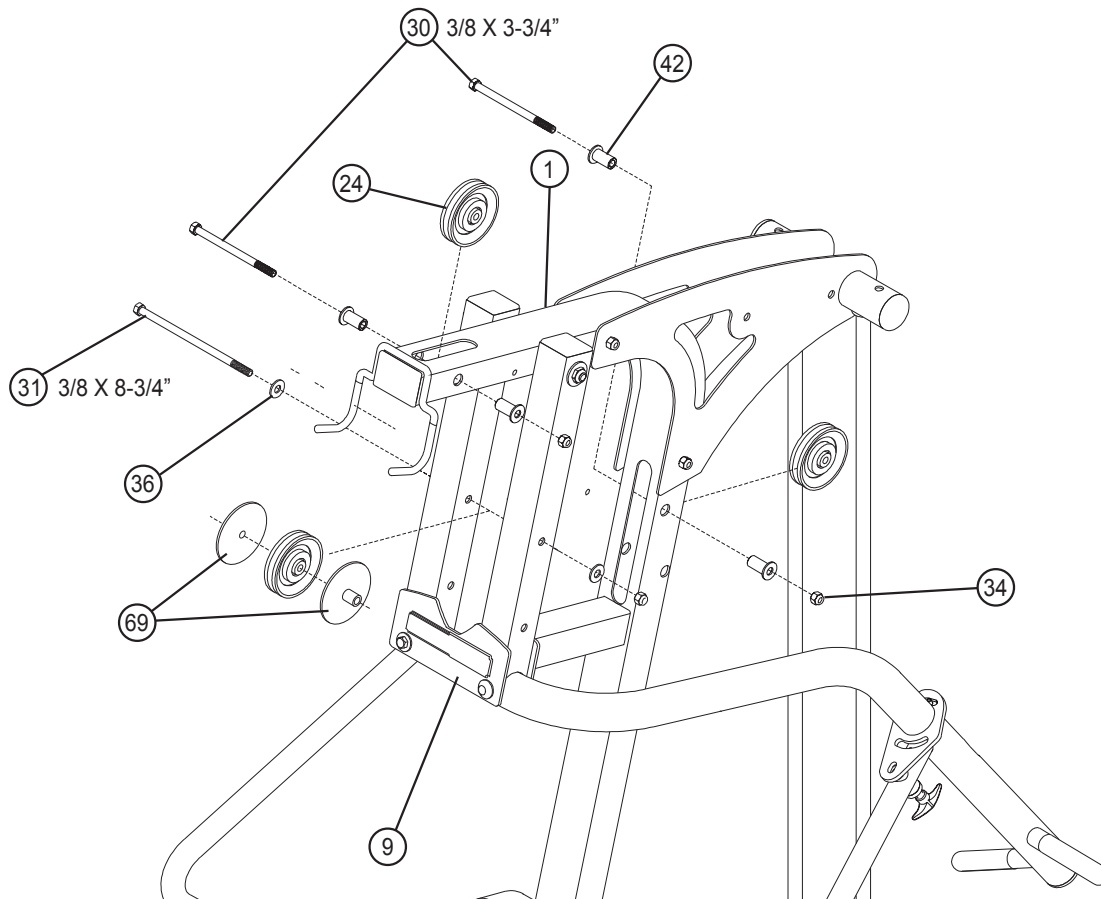
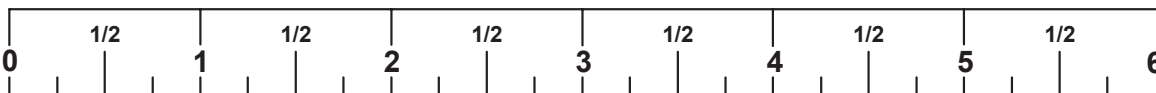

FIGURE 13

STEP 13:

- Refer to the cable ILLUSTRATION “A” on page 14 for cable routing while installing pulleys.
- Assemble two 3-1/2” PULLEYS (24) into the FRAME (1) using two 3/8 X 3-3/4” BOLTS (30), four 3/8 X 1-1/16” FLANGE SPACERS (42) and two 3/8” LOCK NUTS (34) and tighten securely.
- Assemble one 3-1/2” PULLEY (24) into the PRIMARY PIVOT (9) upper hole using one 3/8 X 8-3/4” BOLT (31), two 3/8” FLAT WASHERS (36), two PULLEY GUARD SPACERS (69) and one 3/8” LOCK NUT (34) and tighten securely.



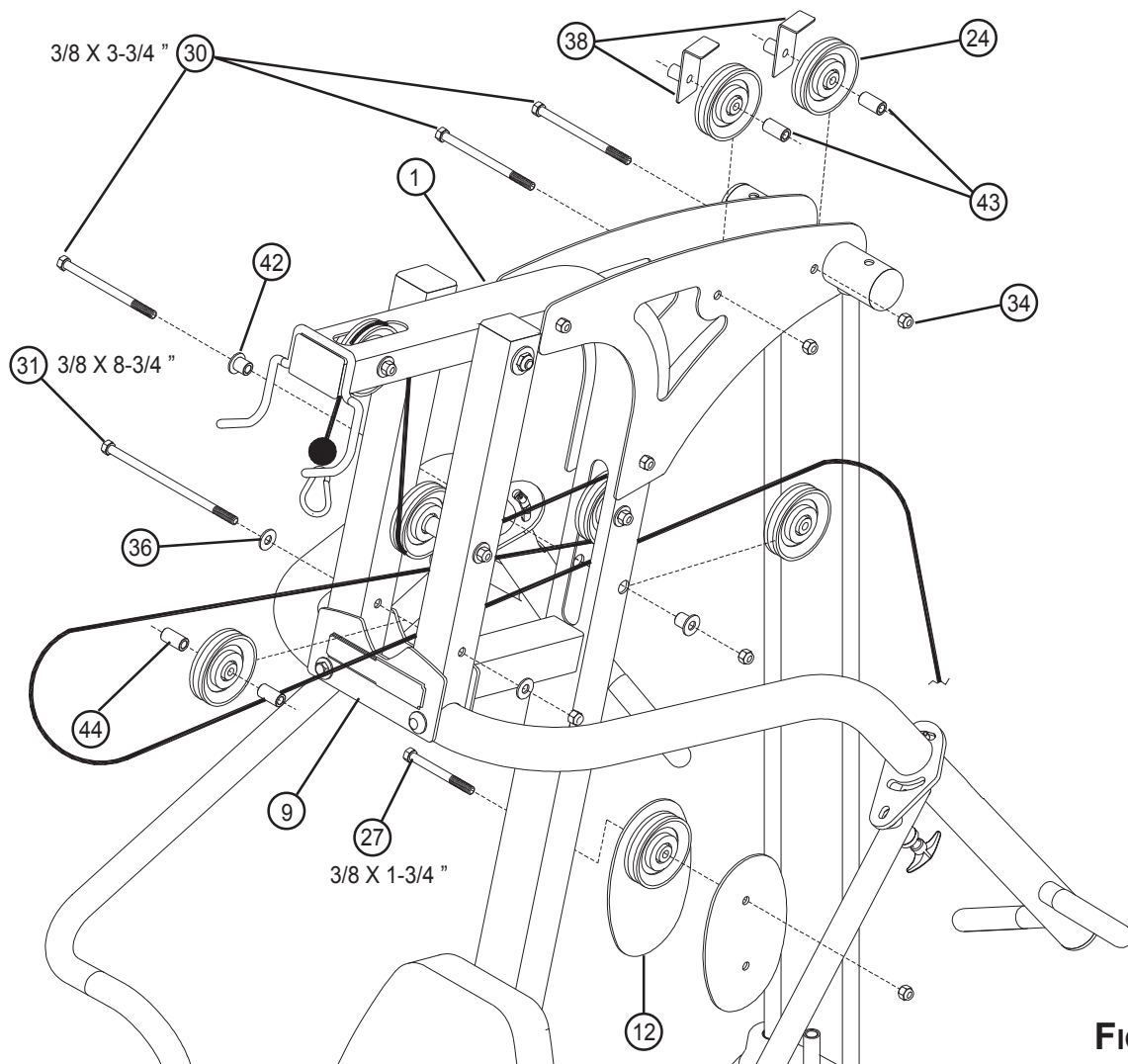
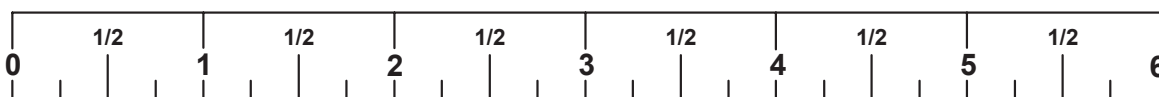

FIGURE 14

STEP 14:

- Refer to the cable ILLUSTRATION “A” on page 14 for cable routing while installing pulleys.
- Assemble one 3-1/2” PULLEY (24) into the PRIMARY PIVOT (9) lower hole using one 3/8 X 8-3/4” BOLT (31), two 3/8” FLAT WASHERS (36), two 3/8 X 1-3/8” SPACERS (44) and one 3/8” LOCK NUT (34) and tighten securely.
- Assemble one 3-1/2” PULLEY (24) to the FRAME (1) using one 3/8 X 3-3/4” BOLT (30), two 3/8 X 1-1/16” FLANGE SPACERS (42), and one 3/8” LOCK NUT (34). Tighten securely.
- Loosely assemble one 3-1/2” PULLEY (24) between the PULLEY PLATES (12) using one 3/8 X 1-3/4” BOLT (27) and one 3/8” LOCK NUT (34).
- Assemble two 3-1/2” PULLEYS (24) between the left and right BOOM PLATES (4 & 5) using two 3/8 X 3-3/4” BOLTS (30), two 3/8 X 1” SPACERS (43), two 3-1/2” CABLE GUARDS (38) and two 3/8” LOCK NUTS (34).



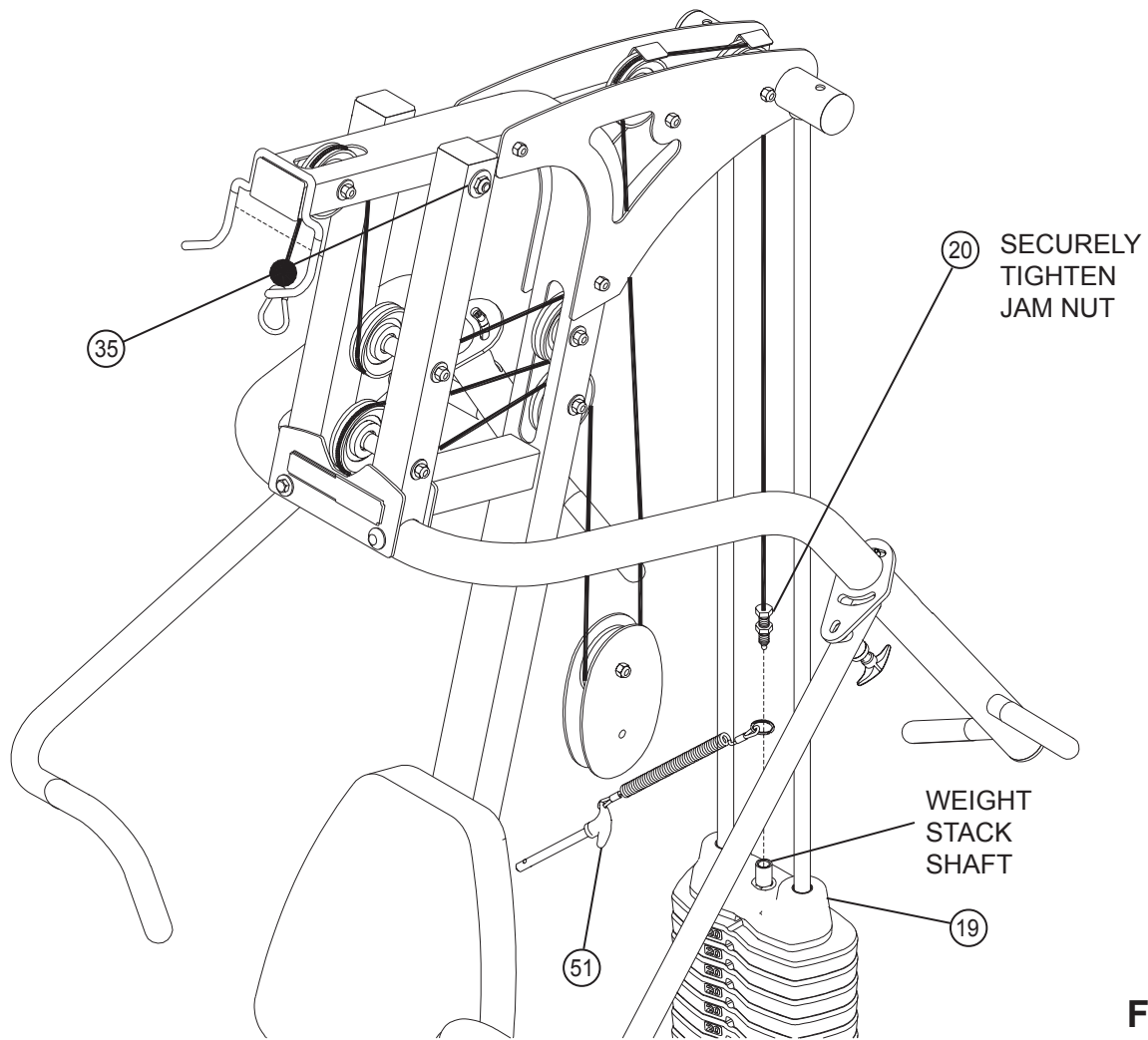
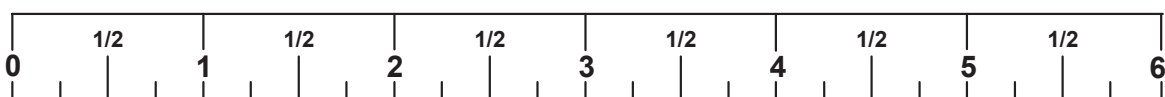

FIGURE 15

STEP 15:

- Slip the ring of the WEIGHT SELECTOR PIN (51) down the WEIGHT STACK SHAFT and insert the pin into one of the weights.
- Screw the end of the LAT CABLE (20) into the top of the WEIGHT STACK SHAFT on the HEAD PLATE ASSEMBLY (19) and securely tighten the JAM NUT as shown in FIGURE 15.
- Securely tighten the 1/2" LOCK NUT (35) on the PRIMARY PIVOT of the PRESS ARM (9).



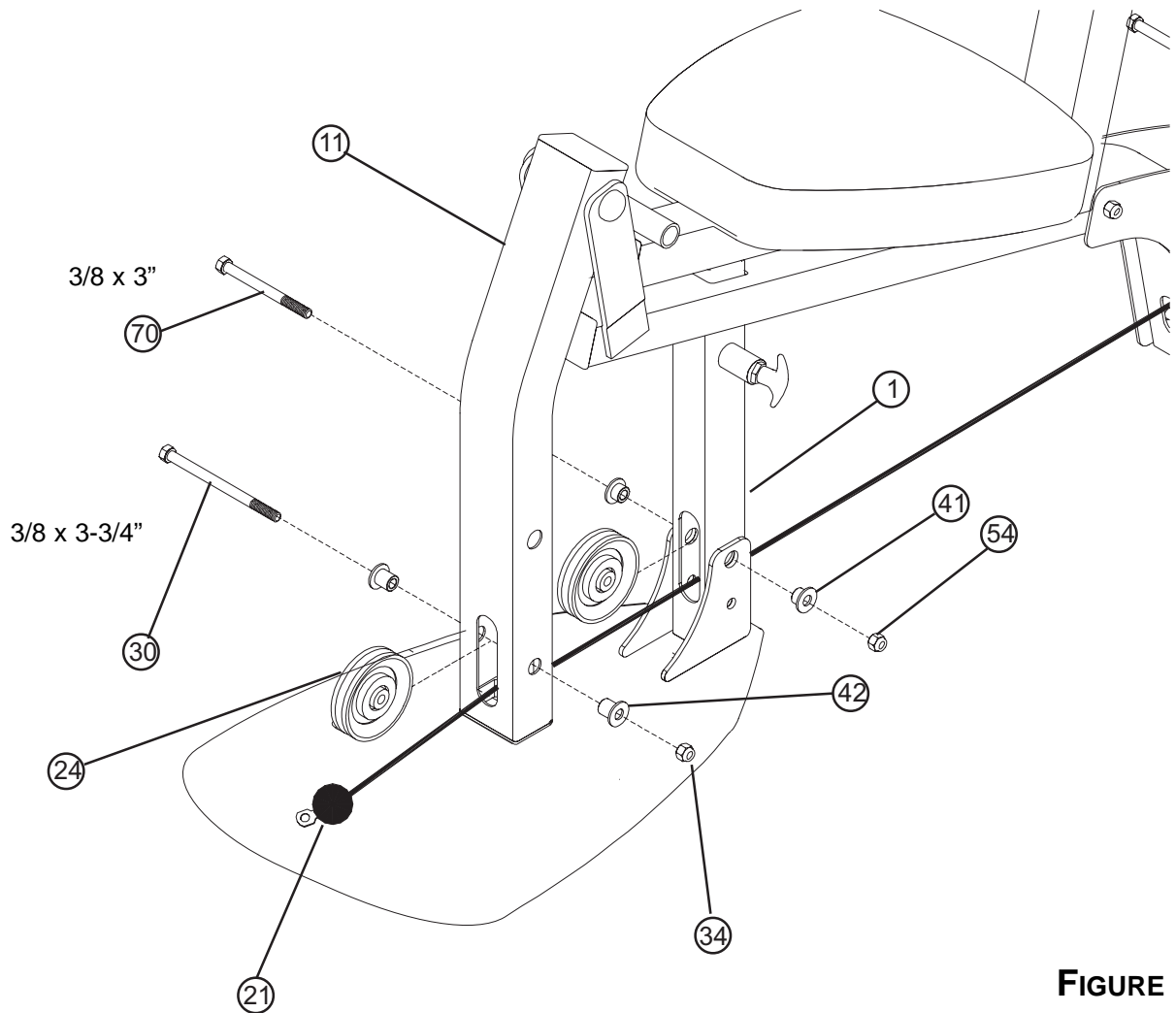

FIGURE 16

STEP 16:

- Refer to the cable ILLUSTRATION “A” on page 14 for cable routing while installing pulleys.
 - **CABLE MUST BE POSITIONED BETWEEN THE PULLEY AND THE LOWER BOLT ASSEMBLY ON THE LEG PEDESTAL (11) AND THE FRAME (1).**
 - Securely assemble the ball end of the LOW CABLE (21) and one 3-1/2” PULLEY (24) to the LEG PEDESTAL (11) using one 3/8 X 3-3/4” BOLT (30), two 3/8” X 1-1/16” FLANGE SPACERS (42), two 3/8” WASHERS (36), and one 3/8” LOCK NUT (34).
 - Securely assemble one 3-1/2” PULLEY (24) and two 3/8 X 3/4 FLANGE SPACERS (41) to the FRAME (1) using one 3/8 X 3” BLACK BOLT (70) and one 3/8” BLACK LOCK NUT (54).
- Note:** The LEG CABLE (21) should be routed over the retaining bolt as shown in FIGURE 16.

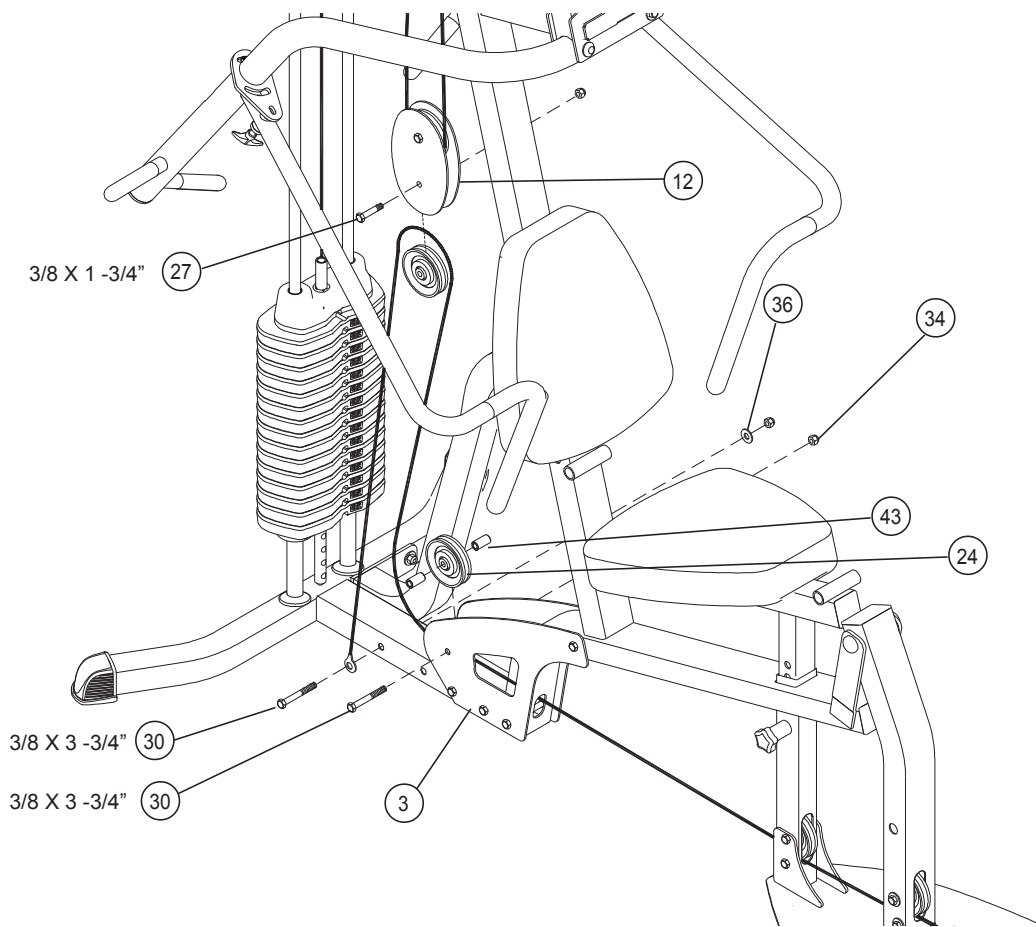
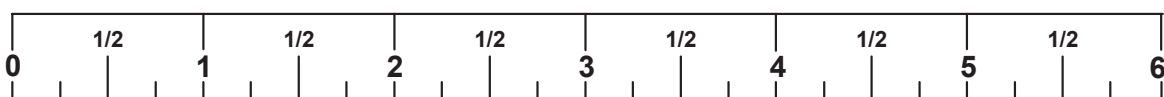

FIGURE 17

STEP 17:

- Refer to the cable ILLUSTRATION “A” on page 14 for cable routing while installing pulleys.
- Assemble one 3-1/2” PULLEY (24) between the BASE PLATES (3) using one 3/8 X 3-3/4” BOLT (30), two 3/8 X 1” SPACERS (43), and one 3/8” LOCK NUT (34). Tighten securely.
- Loosely assemble one 3-1/2” PULLEY (24) between the PULLEY PLATES (12) using one 3/8 X 1-3/4” BOLT (27) and one 3/8” LOCK NUT (34).
- Secure the end of the LOW CABLE (21) using one 3/8 x 3-3/4” BOLT (30), one 3/8” FLAT WASH-ER (36) and one 3/8” LOCK NUT (34) as shown in FIGURE 17.
- Tighten both 3-1/2” PULLEYS (24) located on the PULLEY PLATES (12).



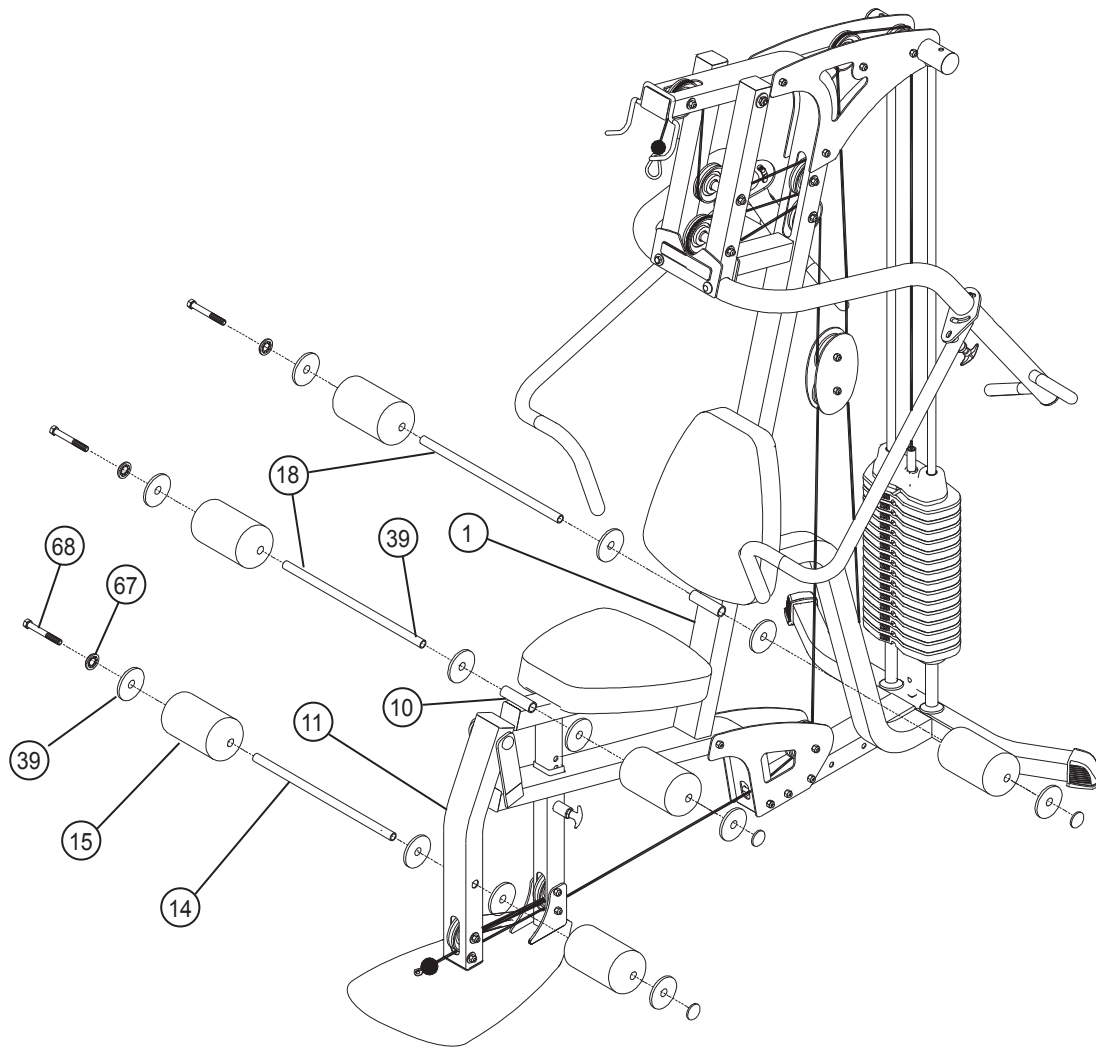
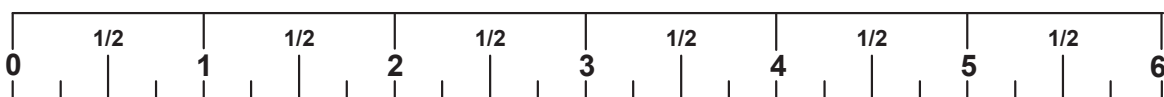
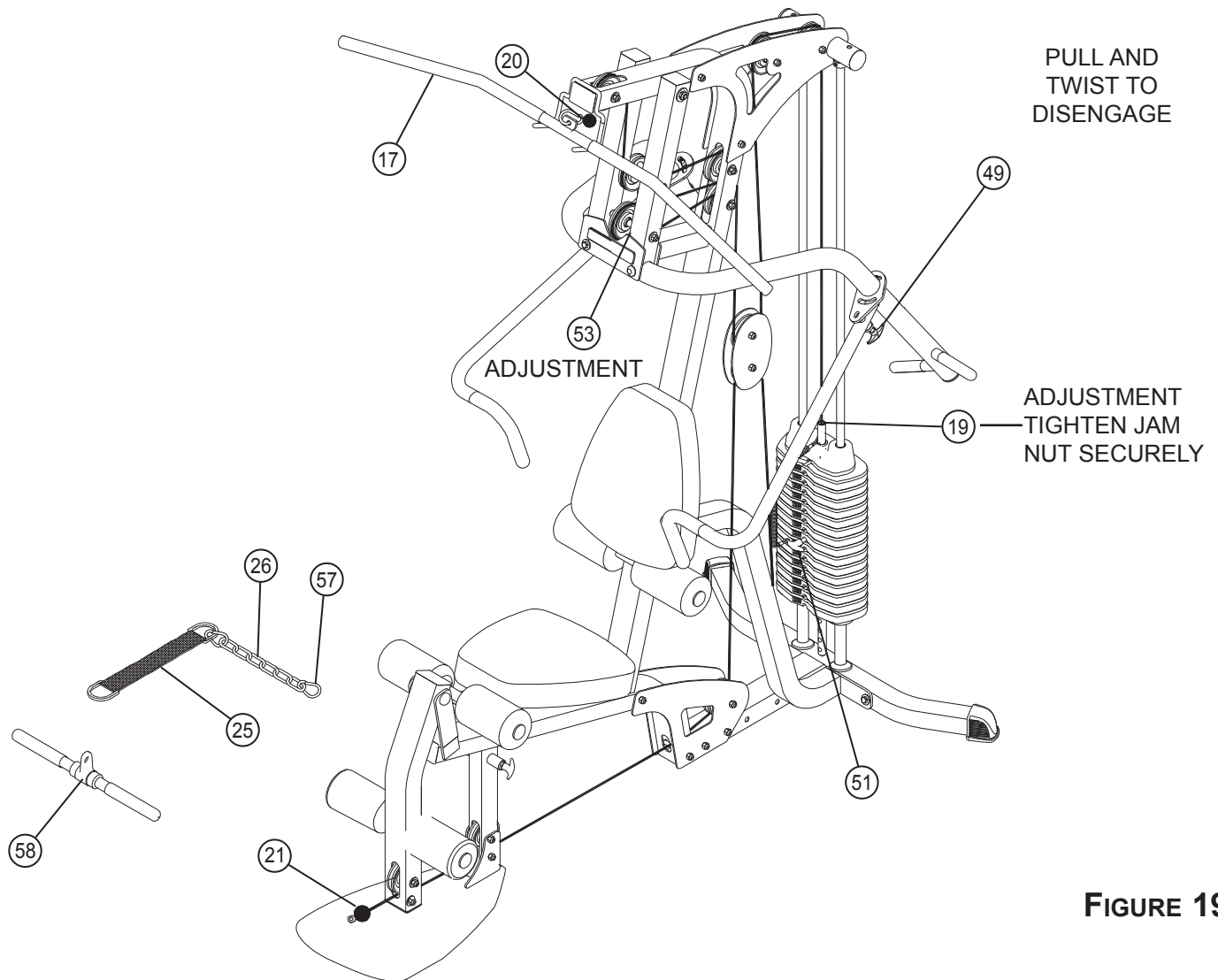

FIGURE 18

STEP 18:

- Attach two 4 X 7" ROLLER PADS (15) to the LEG PEDESTAL (11) using one 3/4 X 17-3/8" TUBE (14), four PLASTIC WASHERS (39), two ROLLER PAD CAPS (67) and two 5/16 x 1" BUTTON HEAD BOLTS (68) as shown in FIGURE 18.
- Attach two 4 X 7" ROLLER PADS (15) to the SEAT ADJUST (10) using one 3/4 X 18-1/8" TUBE (18), four PLASTIC WASHERS (39), two ROLLER PAD CAPS (67) and two 5/16 x 1" BUTTON HEAD BOLTS (68) as shown in FIGURE 18.
- Attach two 4 X 7" ROLLER PADS (15) to the FRAME (1) using one 3/4 X 18-1/8" TUBE (18), four PLASTIC WASHERS (39), two ROLLER PAD CAPS (67) and two 5/16 x 1" BUTTON HEAD BOLTS (68) as shown in FIGURE 18.





STEP 19:

- If upon completion of assembly, the HEAD PLATE (19) does not sit on top of the first WEIGHT PLATE (22), push the HEAD PLATE (19) down, insert the WEIGHT SELECTOR PIN (51) and perform several repetitions at the press station. This will relax the cable system and prevent the HEAD PLATE (19) from lifting up. See FIGURE 19.
- If after completing the previous step, the HEAD PLATE (19) still does not sit on top of the first WEIGHT PLATE (22), or if there is excess slack in the cable system, adjust the threaded end of the LAT CABLE (20) and ADJUSTABLE GLIDE (53) accordingly and retighten the jam nuts. See FIGURE 19.
- For maximum performance, the HEAD PLATE (19) should just barely sit on the top WEIGHT PLATE (22).
- Attach the LAT BAR (17) to the ball end of the LAT CABLE (20) using one SNAP LINK (57) as shown in FIGURE 19.
- Attach the ANKLE STRAP (25) to the LINK CHAIN (26) using one SNAP LINK (57) as shown in FIGURE 19.
- Attach the LOW ROW BAR (58) to the ball end of the LOW CABLE (21) using one SNAP LINK (57).

STEP 20:

PARTS LIST

KEY	DESCRIPTION	QTY	KEY	DESCRIPTION	QTY
1	LEFT SHROUD	1	5	3/8 X 1" BUTTON HEAD BOLT	8
2	RIGHT SHROUD	1	6	3/8" BLACK SAE WASHER	8
3	TOP SHROUD BRACKET	1	7	3/8 X 2-1/2" BOLT	2
4	BOTTOM SHROUD BRACKET	1	8	3/8" LOCK NUT	2

FIGURE 20

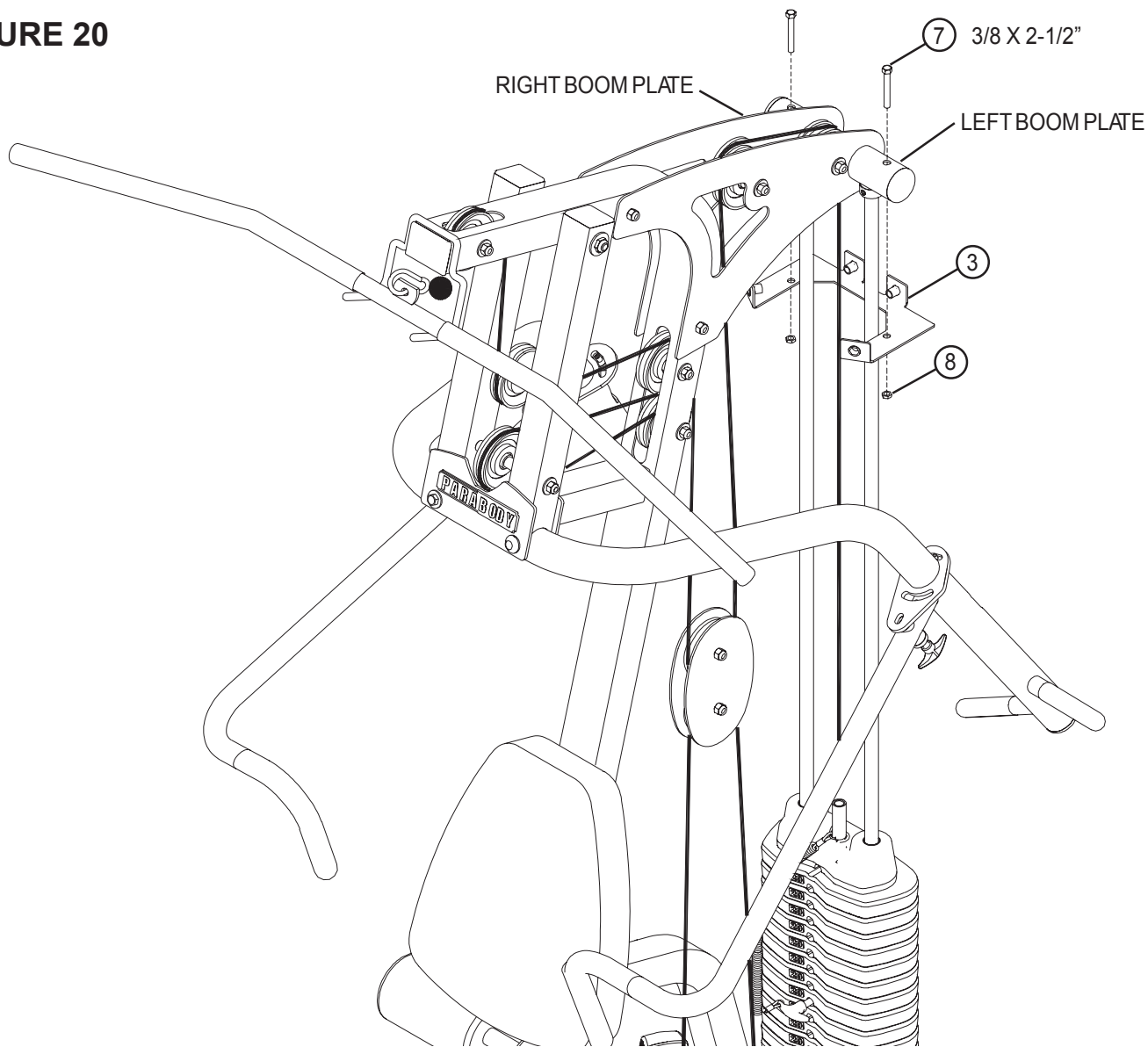

- SECURELY assemble the TOP SHROUD BRACKET (3) to the RIGHT and LEFT BOOM PLATES using two 3/8 X 2-1/2" BOLTS (7) and two 3/8" LOCK NUTS (8) as shown in FIGURE 20. The BOTTOM SHROUD BRACKET (4) was previously inserted under the weight stack.

FIGURE 21

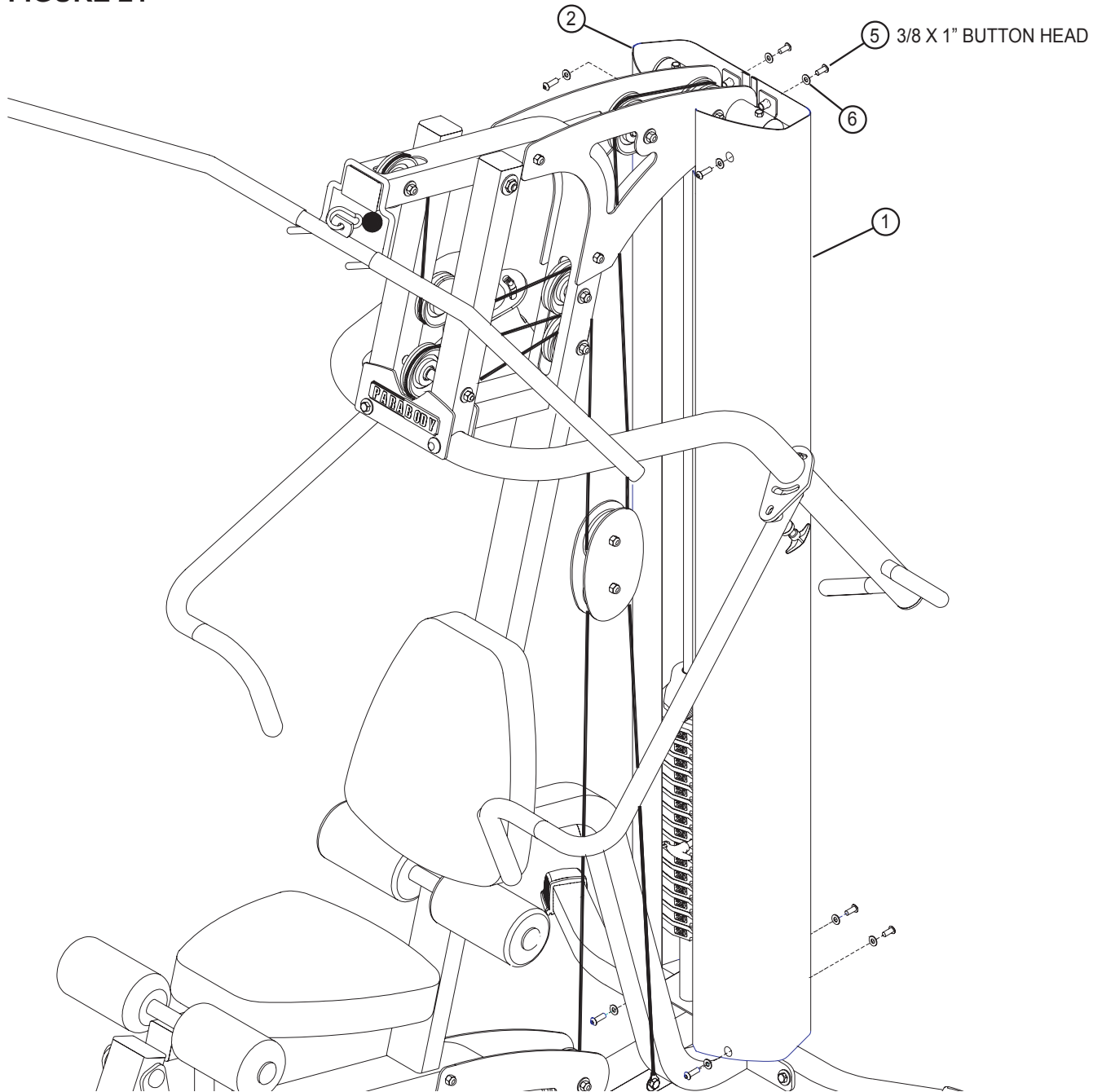

STEP 21:

- SECURELY assemble the LEFT SHROUD (1) and RIGHT SHROUD (2) to the TOP (3) and BOTTOM (4) SHROUD BRACKETS using eight 3/8 X 1" BUTTON HEAD BOLTS (5) and eight 3/8" BLACK SAE WASHERS (6) as shown in FIGURE 21.

Note: You can hang the exercise cards on the M4 X 20mm SHOULDER BOLT that is preassembled to the SHROUD.

THANK YOU FOR PURCHASING THE LIFE FITNESS G2 GYM SYSTEM!

MAINTENANCE

Please note:

- We recommend cleaning your product (pads and frame) on a regular basis, using warm soapy water. Touch-up paint can be purchased from your Life Fitness customer service representative at 1-800-351-3737.
- Inspect equipment daily. Tighten all loose connections and replace worn parts immediately. Failure to do so may result in serious injury.
- Lubricate guide rods with a teflon based (or equivalent) lubricant on a regular basis.
- **PLEASE RECORD THE INFORMATION REQUESTED BELOW. IN THE EVENT THAT YOUR EQUIPMENT REQUIRES SERVICE YOU WILL BE ASKED FOR THIS INFORMATION.**

Remember to fill out your registration card on-line at www.lifefitness.com/registration

MODEL #: _____

SERIAL #: _____

DATE OF PURCHASE: _____

DEALER'S NAME: _____

DEALER'S PHONE #: _____

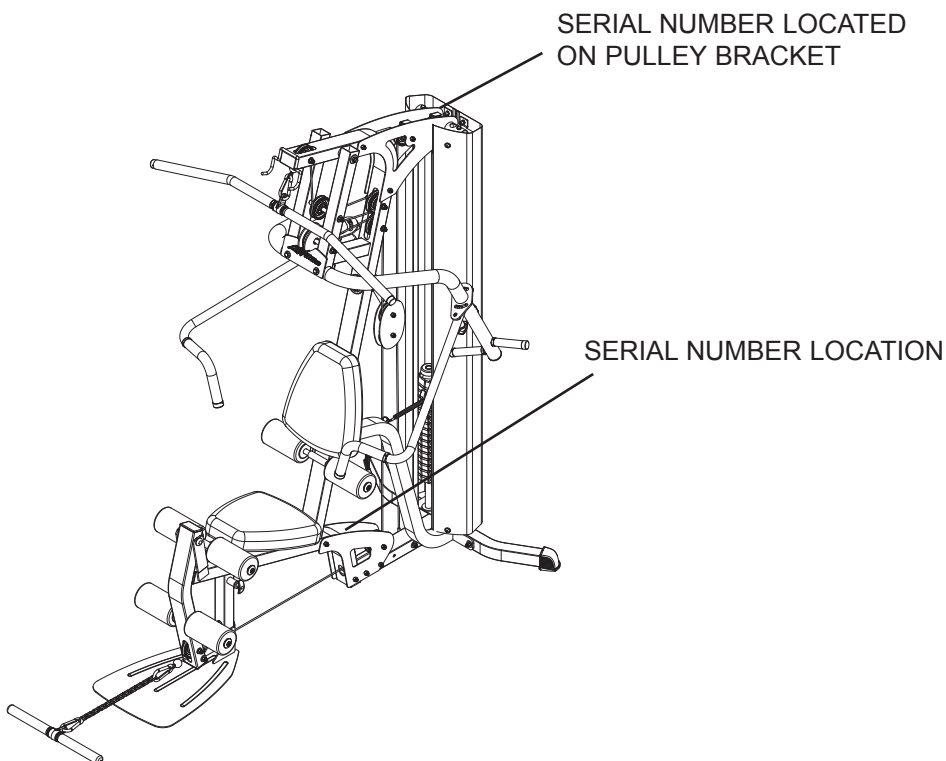

WARRANTY

Life Fitness extends the following LIMITED WARRANTY to the original owner of the Life Fitness products. The Warranty terms apply to IN HOME USE ONLY.

1. **LIMITED WARRANTY ON FRAME AND WELDS.** If the frame of the Life Fitness product or a weld should crack or break, it will be repaired or replaced by Life Fitness. Terms: Lifetime – for so long as the Customer owns the Life Fitness product.
2. **LIMITED WARRANTY ON PARTS.** If the following parts are defective in material or workmanship, Life Fitness will supply replacement parts: all bolts, nuts, washers, bearings, bushings, pulleys, thumbscrews, collars, cable retaining clips, adjustable pre-stretch slides, roller pad shafts, allen head bolts, weight selector pin, weight stack shaft, set screws, protector caps, adjustment chain, cotter pin, plunger, spring and knob. Terms: Lifetime – for so long as the Customer owns the Life Fitness product.
3. **LIMITED WARRANTY ON CABLES AND UPHOLSTERY.** If the coated cables or upholstery are defective in material or workmanship, Life Fitness will repair or replace them, at its option. Terms: Three (3) years.
4. **CONDITIONS AND EXCEPTIONS.** Any product misuse, abuse or alteration, any attempt to repair by a person other than an authorized Life Fitness Service Center, any improper assembly, accident, or any other condition resulting from occurrences beyond the control of Life Fitness will void this Limited Warranty.
5. **REPLACEMENT AND REPAIR EXPENSES.** Life Fitness will provide only replacement parts or repair under this warranty. The Owner is responsible for all other costs. Such costs may include, but are not limited to: a. labor charges for service, removal, repair or reinstallation of the Life Fitness product or any component part; b. shipping, delivery, handling and administrative charges for returning parts to Life Fitness; and c. all necessary or incidental costs related to installation of the replacement parts.
6. **SHIPPING.** If shipping by the Owners is deemed necessary (in sole discretion of Life Fitness), parts should be shipped in their original carton or equivalent packaging, fully insured with shipping charges prepaid. Life Fitness will not assume any responsibility for any loss or damage incurred in shipping.
7. **CLAIM PROCEDURES.** If service on your Life Fitness product is required during the warranty period, please contact our Customer Service Department at 1-800-351-3737 for instructions regarding returning or replacing parts. Please have available the following information: (i) the dealer's name; (ii) the date of purchase; (iii) the serial # (s) of your product (the serial number location is called out on the final assembly drawing included with your assembly instruction); (iv) a description of the nature of the problem.
8. **OWNER'S RIGHT.** This Limited Warranty gives you specific legal rights. You may also have other rights, which vary depending on local law.
9. **LIMITATION OF IMPLIED WARRANTIES.** All implied warranties, except to the extent prohibited by applicable law, shall have no greater duration than the warranty period set forth above. There are no warranties which extend beyond the description in this Limited Warranty.

Because local laws do not allow limitations on how long an implied warranty lasts, the above limitations may not apply to you.

10. **DISCLAIMER.** No other express warranty has been made or will be made on behalf of Life Fitness with respect to any Life Fitness product or the operation, repair or replacement of any Life Fitness product. Life Fitness shall not be responsible for injury, loss of use of the Life Fitness product, inconvenience, loss or damage to personal property, whether direct or indirect, and incidental or consequential damages. The above limitation or exclusion may not apply to you.

CORPORATE HEADQUARTERS
5100 North River Road
Schiller Park, Illinois 60176 • U.S.A.
847.288.3300 • FAX: 847.288.3703
800.735.3867 (Toll-free within U.S.A., Canada)

INTERNATIONAL OFFICES

AMERICAS

North America
Life Fitness Inc.

5100 N River Road
Schiller Park, IL 60176 U.S.A
Telephone: +1(847) 288 3300
Fax: +1(847) 288 3703
Service Email: internationalservicesupport@lifefitness.com
Sales/Marketing Email: commercialsales@lifefitness.com
Operating Hours: 7:00 am-6:00 pm (CST)

Brazil
Life Fitness Do Brazil

Av. Dr. Dib Sauaia Neto 1478
Alphaville, Barueri, SP
06465-140
BRAZIL
Telephone: (800) 773 8282
Fax: (+55) 11.4133.2893
Service Email: suporte@lifefitness.com.br
Sales/Marketing Email: lifefitness@lifefitness.com.br
Operating Hours: 8:30 am-17:30 pm (BRT)

Latin America & Caribbean*
Life Fitness Inc.

5100 N River Road
Schiller Park, IL 60176 U.S.A
Telephone: +1(847) 288 3300
Fax: +1(847) 288 3703
Service Email: internationalservicesupport@lifefitness.com
Sales/Marketing Email: commercialsales@lifefitness.com
Operating Hours: 8:00am-5:00pm (CST)

EUROPE, MIDDLE EAST, & AFRICA
(EMEA)

Netherlands & Luxemburg
Life Fitness Atlantic BV

Bijdorpplein 25-31
2992 LB Barendrecht
THE NETHERLANDS
Telephone: (+31) 180 646 666
Fax: (+31) 180 646 699
Service Email: service.benelux@lifefitness.com
Sales/Marketing Email: marketing.benelux@lifefitness.com
Operating Hours: 9.00h-17.00h (CET)

United Kingdom & Ireland
Life Fitness UK LTD

Queen Adelaide
Ely, Cambs, CB7 4UB
Telephone: General Office (+44) 1353.666017
Customer Support (+44) 1353.665507
Fax: (+44) 1353.666018
Service Email: uk.support@lifefitness.com
Sales/Marketing Email: life@lifefitness.com
Operating Hours:
General Office: 9.00am - 5.00pm (GMT)
Customer Support: 8.30am - 5.00pm (GMT)

Germany & Switzerland
Life Fitness Europe GMBH

Siemensstrasse 3
85716 Unterschleissheim
GERMANY
Telephone: (+49) 89.31 77 51.0 (Germany)
(+41) 0848 000 901 (Switzerland)
Fax: (+49) 89.31 77 51.99 (Germany)
(+41) 043 818 07 20 (Switzerland)
Service Email: kundendienst@lifefitness.com
Sales/Marketing Email: kundenberatung@lifefitness.com
Operating Hours: 9.00h-17.00h (CET)

Austria
Life Fitness Austria

Vertriebs G.m.b.H.
Dücker gasse 7-9/3/36
1220 Vienna
AUSTRIA
Telephone: (+43) 1.61.57.198
Fax: (+43) 1.61.57.198.20
Service Email: kundendienst@lifefitness.com
Marketing/Sales Email: kundenberatung@lifefitness.com
Operating Hours: 9.00h-17.00h (CET)

Spain
Life Fitness IBERIA

C/Frederic Mompou 5,1^o1^a
08960 Sant Just Desvern Barcelona
SPAIN
Telephone: (+34) 936 724 660
Fax: (+34) 936 724 670
Service Email: info.iberia@lifefitness.com
Sales/Marketing Email: info.iberia@lifefitness.com
Operating Hours:
9.00h-18.00h (Monday-Thursday) (GMT)
8.30h-15.00h (Friday) (GMT)

Italy
Life Fitness ITALIA S.R.L.

Via Crivellini 7/N
37010 Affi Verona
ITALY
Telephone: (+39) 045.7237811
Fax: (+39) 045.7238197
Service Email: assistenzatecnica@lifefitness.com
Sales/Marketing Email: info@lifefitnessitalia.com
Operating Hours: 8.30h -18.00h (CET)

Belgium
Life Fitness Benelux NV

Parc Industriel de Petit-Rechain
4800 Verviers
BELGIUM
Telephone: (+32) 87 300 942
Fax: (+32) 87 300 943
Service Email: service.benelux@lifefitness.com
Sales/Marketing Email: marketing.benelux@lifefitness.com
Operating Hours: 9.00h -17.00h (CET)

All Other EMEA countries & distributor business C-EMEA*

Bijdorpplein 25-31
2992 LB Barendrecht
THE NETHERLANDS
Telephone: (+31) 180 646 666
Fax: (+31) 180 646 699
Service Email: service.db.cemea@lifefitness.com
Sales/Marketing Email: marketing.db.cemea@lifefitness.com
Operating Hours: 9.00h-17.00h (CET)

ASIA PACIFIC (AP)

Japan
Life Fitness Japan

Nippon Brunswick Bldg., #8F
5-27-7 Sendagaya
Shibuya-Ku, Tokyo
JAPAN 151-0051
Telephone: (+81) 3.3359.4309
Fax: (+81) 3.3359.4307
Service Email:
service@lifefitnessjapan.com
Sales/Marketing Email
sales@lifefitnessjapan.com
Operating Hours: 9.00h-17.00h (GMT)

China and Hong Kong
Life Fitness Asia Pacific LTD

Room 2610, Miramar Tower
132 Nathan Road
Tsimshatsui, Kowloon
HONG KONG
Telephone: (+852) 2891.6677
Fax: (+852) 2575.6001
Service Email: HongKongEnquiry@lifefitness.com
Sales/Marketing Email: ChinaEnquiry@lifefitness.com
Operating Hours: 9.00h-18.00h (GMT)

All Other Asia Pacific countries & distributor business Asia Pacific*

Room 2610, Miramar Tower
132 Nathan Road
Tsimshatsui, Kowloon
HONG KONG
Telephone: (+852) 2891.6677
Fax: (+852) 2575.6001
Service Email: HongKongEnquiry@lifefitness.com
Sales/Marketing Email: ChinaEnquiry@lifefitness.com
Operating Hours: 9.00h-18.00h (GMT)

* Also check www.lifefitness.com for local representation or distributor/dealer.