

HAMMER[®] STRENGTH

HAMMER STRENGTH[®]

Plate Loaded Super Squat Press Assembly Instructions

PL-SSP



Corporate Headquarters

Columbia Centre III, 9525 Bryn Mawr Avenue, Rosemont, IL 60018 • U.S.A.
847.288.3300 • FAX: 847.288.3703
Service phone number: 800.351.3737 (toll-free within U.S.A., Canada)
Global Website: www.lifefitness.com

International Offices

AMERICAS

North America

Life Fitness, LLC

Columbia Centre III
9525 Bryn Mawr Avenue
Rosemont, IL 60018 U.S.A.
Telephone: (847) 288 3300
Service Email:
customersupport@lifefitness.com
Sales/Marketing Email:
commercialsales@lifefitness.com

Brazil

Life Fitness Brasil

Av. Rebouças, 2315
Pinheiros
São Paulo, SP 05401-300
BRAZIL
SAC: 0800 773 8282 option 2
Telephone: +55 (11) 3095 5200 option 2
Service Email: suportebr@lifefitness.com
Sales/Marketing Email:
vendasbr@lifefitness.com

Latin America and Caribbean*

Life Fitness, LLC

Columbia Centre III
9525 Bryn Mawr Avenue
Rosemont, IL 60018 U.S.A.
Telephone: (847) 288 3300
Service Email:
customersupport@lifefitness.com
Sales/Marketing Email:
commercialsales@lifefitness.com

EUROPE, MIDDLE EAST, and AFRICA (EMEA)

Belgium, Netherlands, and Luxemburg

Life Fitness (Atlantic) B.V.

Fascinatio Boulevard 230, 4th Fl - Bldg B
3065WB, Rotterdam
The Netherlands
+31 88 646 6666
Service Email:
service.benelux@lifefitness.com
Sales/Marketing Email:
marketing.benelux@lifefitness.com

United Kingdom

Life Fitness UK LTD

Unit 109^a
Lancaster Way Business Park
Ely, Cambs, CB6 3NX
Telephone: General Office (+44)
1353.666017
Customer Support (+44) 1353.665507
Service Email: uk.support@lifefitness.com
Sales/Marketing Email: life@lifefitness.com

Germany, Austria, and Switzerland

Life Fitness Europe GMBH

Neuhofweg 9
85716 Unterschleißheim
GERMANY
Telephone:
+49 (0) 89 / 31775166 Germany
+43 (0) 1 / 6157198 Austria
+41 (0) 848 / 000901 Switzerland
Service Email:
kundendienst@lifefitness.com
Sales/Marketing Email:
vertrieb@lifefitness.com

Spain

Life Fitness IBERIA

C/Frederic Mompou 5,1^o^a
08960 Sant Just Desvern Barcelona
SPAIN
Telephone: (+34) 93.672.4660
Service Email:
servicio.tecnico@lifefitness.com
Sales/Marketing Email:
info.iberia@lifefitness.com

All Other EMEA Countries and Distributor Business EMEA*

Life Fitness (Atlantic) B.V.

Fascinatio Boulevard 230, 4th Fl - Bldg B
3065WB, Rotterdam
The Netherlands
+31 88 646 6666
Service Email:
emeaseservicesupport@lifefitness.com

ASIA PACIFIC (AP)

Japan

Life Fitness Japan, Ltd

4-17-33 Minami Aoyama 1F/B1F
Minato-ku - Tokyo 107-0062
Japan
Telephone: (+81) 0120.114.482
Fax: (+81) 03-5770-5059
Service Email: service.lfj@lifefitness.com
Sales/Marketing Email:
sales@lifefitnessjapan.com

Hong Kong

Life Fitness Asia Pacific LTD

26/F, Global Trade Square
21 Wong Chuk Hang Road
Wong Chuk Hang
Hong Kong
Telephone: (+852) 25756262
Fax: (+852) 25756894
Service Email: service.hk@lifefitness.com
Sales/Marketing Email:
marketing.hk.asia@lifefitness.com

All Other Asia Pacific countries and distributor business Asia Pacific*

Life Fitness Asia Pacific LTD

26/F, Global Trade Square
21 Wong Chuk Hang Road
Wong Chuk Hang
Hong Kong
Telephone: (+852) 25756262
Fax: (+852) 25756894
Service Email: service.ap@lifefitness.com
Sales/Marketing Email:
marketing.hk.asia@lifefitness.com

*Also check www.lifefitness.com for local representation or distributor/dealer

User and Service Documents Link

<https://fn.fit/KnowledgeBase>

<https://fn.fit/SupportDocuments>

Additional information is available online using the links above.

تتوفر معلومات إضافية على الإنترنت باستخدام الرابط أعلاه.

点击上面的链接可在线获取更多信息。

Flere oplysninger er tilgængelige online gennem linket ovenfor.

Bijkomende informatie is online beschikbaar via bovenstaande link.

Vous trouverez plus d'informations en ligne à l'aide du lien ci-dessus.

Zusätzliche Informationen finden Sie online über den oben angegebenen Link.

Ulteriori informazioni sono disponibili online utilizzando il link sopra riportato.

追加情報は上記リンクを使用してオンラインで利用可能です。

상기 링크를 통해 온라인에서 추가 정보를 볼 수 있습니다.

Informações adicionais estão disponíveis on-line, através do link acima.

Дополнительная информация доступна в интернете по ссылке, указанной выше.

Mediante el enlace anterior podrá acceder a información adicional en línea.

Ytterligare information finns online genom att använda länken ovan.

İnternet üzerinden daha fazla bilgi edinmek için yukarıdaki bağlantıyı kullanabilirsiniz.

هناك معلومات إضافية متاحة على الإنترنت باستخدام الرابط أعلاه.

Informazio osagarria eskuragarri dago goiko estekaren bidez.

Допълнителна информация можете да намерите онлайн, като използвате връзката по-горе.

Mitjançant l'enllaç anterior podreu accedir a informació addicional en línia.

使用上面的連結線上提供額外資訊。

Dodatne informacije možete pronaći na internetu sljedeći vezu iznad.

ከላይ የተቀመጠውን አገናኝ(ሊንክ) በመጠቀም መረጃዎች አንላይን ያገኛሉ።

Lisätietoja on saatavissa verkosta käyttämällä yllä olevaa linkkiä.

Wubetumi anya nsem afoforo aka ho wa websait so denam asem a ewo atifi ho a wubemia so so.

Πρόσθετες πληροφορίες είναι διαθέσιμες online χρησιμοποιώντας το σύνδεσμο παραπάνω.

מידע נוסף אפשר לקבל באינטרנט באמצעות הקישור לעיל.

További információ elérhető online, a fenti hivatkozás segítségével.

Viðbótarupplýsingar eru fáanlegar á netinu með því að smella á tengilinn hér fyrir ofan.

Plus indicium per superum situm potes invenire.

മുകളിലുള്ള ലിങ്ക് ഉപയോഗിച്ച് ഓൺലൈനിൽ കൂടുതൽ വിവരങ്ങൾ ലഭ്യമാണ്.

Ytterligere informasjon er tilgjengelig på nettet via linken ovenfor.

Dodatkowe informacje są dostępne online pod powyższym odnośnikiem.

Informações adicionais estão disponíveis online a usar o link acima.

Informații suplimentare sunt disponibile online, utilizând link-ul de mai sus.

Dodatne informacije dostupne su na mreži putem gornjeg linka.

Ďalšie informácie sú dostupné online na vyššie uvedenom odkaze.

Table of Contents

Safety

Safety Information.....	6
Product Labels.....	8
Label Locations.....	9

Assembly

Component and Hardware List.....	10
Tools Required.....	10
Assembly Procedure.....	11

Product Information

Bolt to Floor Guide

Introduction.....	20
Delivery and Installation Tips.....	20
Anchor Type - Static.....	20
Anchor Specifications.....	21
Pullout Force.....	21
Tools Required.....	21
Static Anchor Procedure.....	22
Foot Dimensions.....	24

Life Fitness® is a registered trademark.

Gym Wipes® is a registered trademark of the 2XL Corporation. PureGreen 24 is a trademark of Pure Green.

© Copyright 2025, Life Fitness, LLC. All Rights Reserved. Life Fitness, Hammer Strength, Cybex, ICG and SCIFIT are registered trademarks of Life Fitness, LLC and its affiliated companies and subsidiaries. Disclaimer: Images and specifications are current as of the date of publication and are subject to change.

Columbia Center III - 9525 Bryn Mawr Ave., Rosemont, IL 60018 • 847-288-3300 •

www.lifefitness.com • 1028243-0001 AA • 2025

1. Safety

Safety Information

It is the sole responsibility of the purchaser of Life Fitness products to read the owner's manual and warning labels and instruct all individuals, whether they are the end user or supervising personnel, on proper usage of the equipment.

UNDERSTANDING EACH AND EVERY WARNING TO THE FULLEST IS IMPORTANT. IF ANY OF THESE WARNINGS ARE UNCLEAR, CONTACT Life Fitness CUSTOMER SERVICE IMMEDIATELY AT 1-800-351-3737.

This equipment is categorized as class S per EN ISO 20957-1. As such this equipment is only intended for commercial, institutional and/or studio facilities. It is not intended for home use. Contact Life Fitness with any questions regarding this classification.

It is recommended that all users of Life Fitness exercise equipment be informed of the following information prior to use.

Operating Warnings

⚠ WARNING: This product can expose you to chemicals including Methyl Isobutyl Ketone, which is known to the State of California to cause cancer and birth defects or other reproductive harm. For more information go to <http://www.P65Warnings.ca.gov>

- Life Fitness does not warrant nor guarantee that component parts used in the manufacture of products offered under the Life Fitness are latex-free. Users of these products must take all necessary precautions to prevent accidental contact that could lead to an adverse latex reaction.
- It is the purchaser's sole responsibility to properly instruct its end users and supervising personnel as to the proper operating procedures of all equipment.
- This equipment is not intended for use by children. Keep children under the age of 14 away from the machine.
- Do not allow users to wear loose fitting clothing or jewelry while using equipment. It is also recommended to have users secure long hair back and up to avoid contact with moving parts.
- All bystanders must stay clear of all users, moving parts and attached accessories and components while machine is in operation.

Access Control

- Life Fitness recommends that all commercial fitness equipment be used in a supervised area. It is recommended that the equipment be located in an access controlled area. Control is the responsibility of the facility owner.

Installation

- Life Fitness recommends that all equipment be secured to a solid, level surface to stabilize it and eliminate rocking or tipping over. This must be performed by a licensed contractor. See [Bolt to Floor Guide](#) for installation procedure.

Proper Usage

- Do not use any equipment in any way other than as designed or intended by the manufacturer. It is imperative that Life Fitness equipment is used properly to avoid injury.
- Injuries may result if exercising improperly or excessively. It is recommended that all individuals consult a physician prior to commencing an exercise program. If at any time during exercise you feel faint, dizzy or experience pain, STOP EXERCISING and consult your physician.
- Keep body parts (hands, feet, hair, etc.), clothing and jewelry away from moving parts to avoid injury.

Inspection

- DO NOT attempt to use or repair any accessory approved for use with the equipment which appears to be damaged or worn.
- DO NOT use or permit use of any equipment that is damaged and/or has worn or broken parts. For all Life Fitness equipment, use only replacement parts supplied by Life Fitness.
- Cables and belts pose an extreme liability if used when damaged. Always replace any cable at first sign of wear (consult Life Fitness if uncertain).
- Routinely inspect all accessory clips that join attachments to the cables and replace them at the first sign of wear.
- Maintain labels, name plates and instructional placards. Do not remove labels or instructional placards for any reason. They contain important information. Contact Customer Support to replace any worn, damaged, or unreadable labels or instructional placards and to ensure that you are always using the latest version of labels and instructional placards.

- Equipment Maintenance - Preventative maintenance is the key to smooth operating equipment as well as to keep your liability to a minimum. Equipment needs to be inspected at regular intervals.
- Ensure that any person(s) making adjustments or performing maintenance or repair of any kind is qualified to do so. Life Fitness will provide service and maintenance training at our corporate facility upon request or in the field if proper arrangements are made.
- Before use, examine all accessories approved for use with the Life Fitness equipment for damage or wear.

Warnings and Cautions

- Warning labels indicate a potentially hazardous situation that could result in serious injury or death if the precautions are not observed.
- Caution labels indicate a potentially hazardous situation that could result in serious injury or damage to machine if the precautions are not observed.
- Contact [Customer Support Services](#) to replace any worn, damaged, or unreadable labels and to ensure that you are always using the latest version of labels.

Plate Loaded, Free Weight, and Body Weight Systems

- If the unit is equipped with weight rods, use only Olympic style weight plates (2.0" bore) for training weight. Do not use dumbbells or any means other than those stated to increase weight resistance - See machine specific section for more information.
- Always utilize weight plate retention devices such as straps, clamps or pins.
- Only add weight plates up to the load limits of the unit. Make sure all weight plates are completely placed on the weight rod.
- Never exceed the load rating for any plate loaded station, body weight station, bench or other free weight device; including specific weight rod and band peg limits. See machine specifications for load limit information.
- Contact a Life Fitness representative with any questions regarding proper weights and loading.

Product Labels

General Warning

WARNING

SERIOUS INJURY CAN OCCUR ON THIS EQUIPMENT. YOU MUST FOLLOW THESE PRECAUTIONS TO AVOID INJURY!

1. Before using, read all the warnings and obtain instruction on the use of this machine. Use only for intended exercise. DO NOT modify the machine.
2. Obtain a medical exam before beginning any exercise program.
3. Keep body, hair and clothing free of all moving objects.
4. Inspect the machines before use. DO NOT use if it appears damaged. DO NOT attempt to fix a broken or jammed machine. Notify staff immediately.
5. Always utilize weight plate retention devices.
6. DO NOT exceed the load rating. Seek Assistance.
7. Use only weight plates with 2" (5 cm) bore for training weight. Do not use dumbbells or other means to increase weight resistance. Seek Assistance.
8. Children must not be allowed near this machine. Supervise Teenagers.
9. Manufacturer recommends that all equipment be secured to the floor to stabilize and eliminate rocking or tipping over. Use a licensed contractor.
10. **DO NOT REMOVE THIS LABEL. REPLACE IF DAMAGED.**

8773701

FCC Compliant

Patent:
www.lifefitness.com/patents
EN ISO 20957
TSCA Title VI Compliant



THIS DEVICE COMPLIES WITH PART 15 OF THE FCC RULES. OPERATION IS SUBJECT TO THE FOLLOWING TWO CONDITIONS: (1) THIS DEVICE MAY NOT CAUSE HARMFUL INTERFERENCE, AND (2) THIS DEVICE MUST ACCEPT ANY INTERFERENCE RECEIVED, INCLUDING INTERFERENCE THAT MAY CAUSE UNDESIRE OPERATION.

Serial Number

HAMMER STRENGTH

9525 Bryn Mawr Ave
Rosemont, IL 60018
USA 1-847-288-3300
www.lifefitness.com

Bijdorplan 25-31
2992 LB Barendrecht
The Netherlands
+31 0 180 646 666

CAGE:
00MY5
Class: S



Model:
XXX

Max User Wt: XXlbs XXXkgs
Max Training Wt: XXlbs XXXkgs
Max Storage Wt: XXlbs XXXkgs

SN: XXXXXXXXXXXXX



Manufactured in the USA with US and Foreign parts

Label Locations

IMPORTANT: Verify all labels / decals listed are placed on the product and in the location shown. Replace any missing or damaged labels.

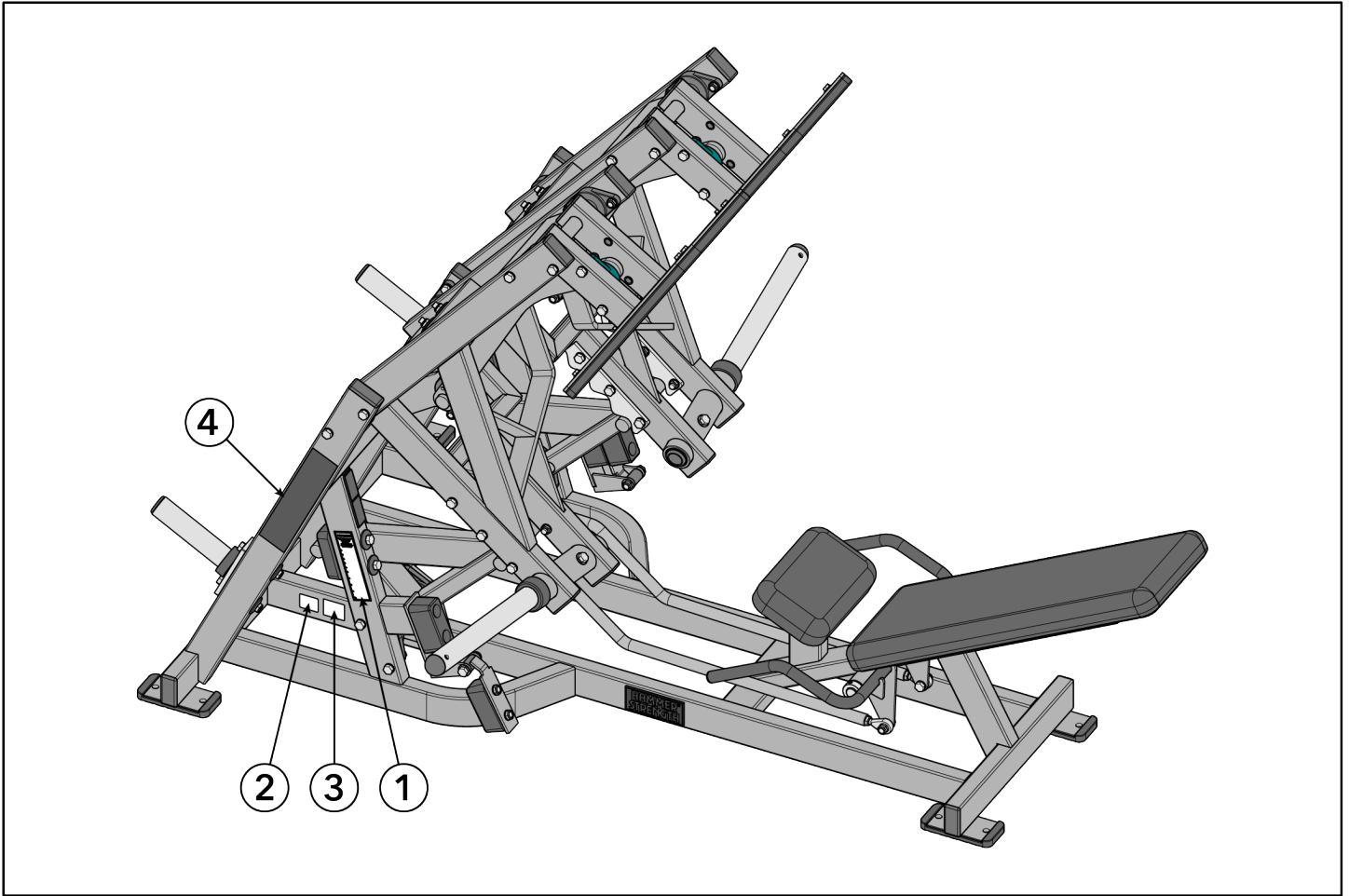

Item	Description	Qty.
1	General Warning	1
2	FCC Compliant	1
3	Serial Number	1
4	Placard	1

2. Assembly

Component and Hardware List

Components

Item	Description	Qty.
1	Weight Tube	2
2	Back Pad	1
3	Seat Pad	1

Hardware

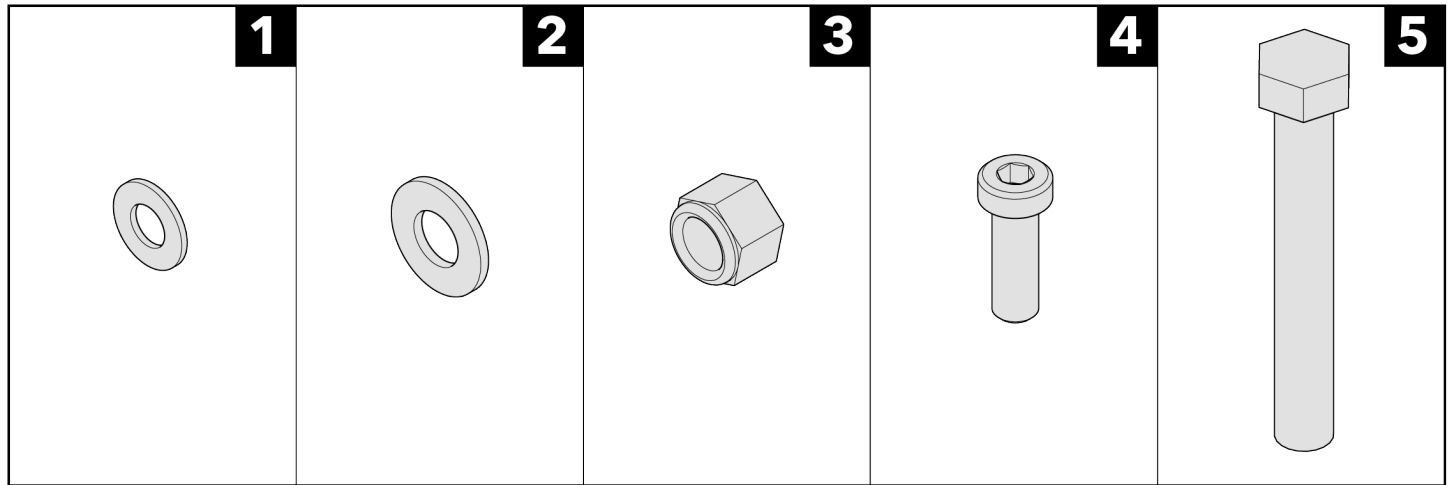

Item	Description	Qty.
1	Washer, 3/8" Flat	6
2	Washer, 1/2" Flat	4
3	Nut, 1/2" Thick Lock	2
4	Screw, M10 x 1.5 30mm	6
5	Bolt, HHB.5x3.5	2

Tools Required

- 1/8" Allen wrench
- 7 mm Allen wrench
- 3/4" wrench (x2)
- Torque wrench

Assembly Procedure

At least two people are required for this procedure.

TIP: Read and understand all instructions thoroughly before assembling this unit. Check all items carefully. If there is damage, see the Customer Service section of this manual for proper procedure to return, replace, or reorder parts.

Fit Unit Through 34" Doorway

The following procedure describes how to fit unit through a 34" / 86cm doorway. If the doorway is wider than 48" / 122cm, skip to [Install Pads](#) procedure.

1. Remove bolts, washers, and nuts securing link assembly to footplate assembly using two 3/4" wrenches.

TIP: Loosen set screw in pillow block bearing using a 1/8" Allen wrench. Slide pillow block bearing down pivot shaft.

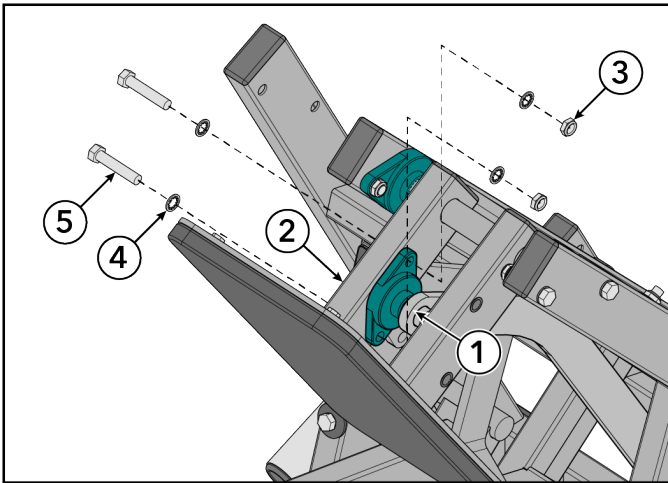

Item	Description	Qty.
1	Link Assembly	1
2	Footplate Assembly	1
3	Nut, 1/2" Thin Lock	2
4	Washer, 1/2" Internal Lock	4
5	Bolt, HHB.5x2.5	2

2. Remove bolts, washers, and nuts securing footplate assembly to workarm assembly using two 3/4" wrenches.

TIP: Loosen set screw in pillow block bearing using a 1/8" Allen wrench. Slide pillow block bearing down pivot shaft.

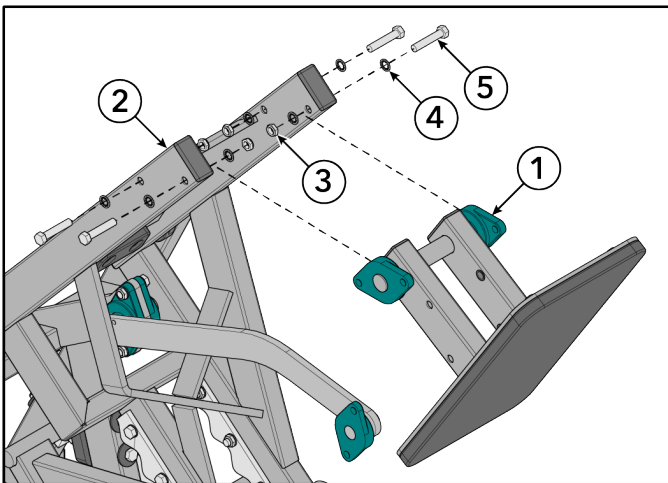

Item	Description	Qty.
1	Footplate Assembly	1
2	Workarm Assembly	1
3	Nut, 1/2" Thin Lock	4
4	Washer, 1/2" Internal Lock	8
5	Bolt, HHB.5x2.5	4

3. Remove bolts, washers, and nuts securing link assembly and pillow block bearing to main frame assembly using two 3/4" wrenches.

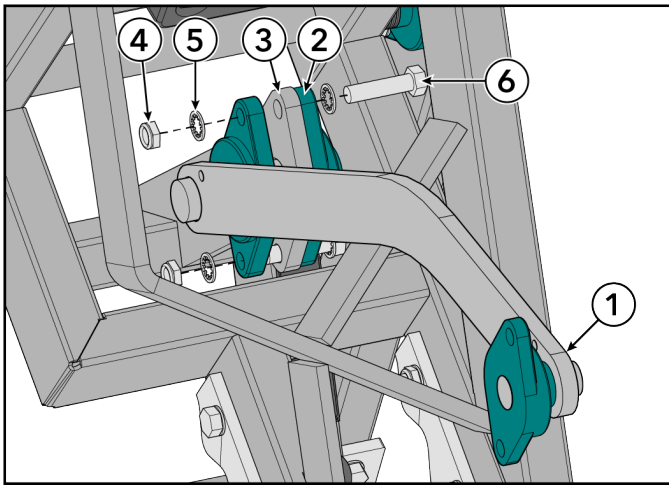

Item	Description	Qty.
1	Link Assembly	1
2	Pillow Block Bearing	1
3	Main Frame Assembly	1
4	Nut, 1/2" Thin Lock	2
5	Washer, 1/2" Internal Lock	4
6	Bolt, HHB.5x2	2

4. Remove bolts, washers, and nuts securing workarm assembly to main frame assembly using two 3/4" wrenches.

TIP: Loosen set screw in pillow block bearing using a 1/8" Allen wrench. Slide pillow block bearing down pivot shaft.

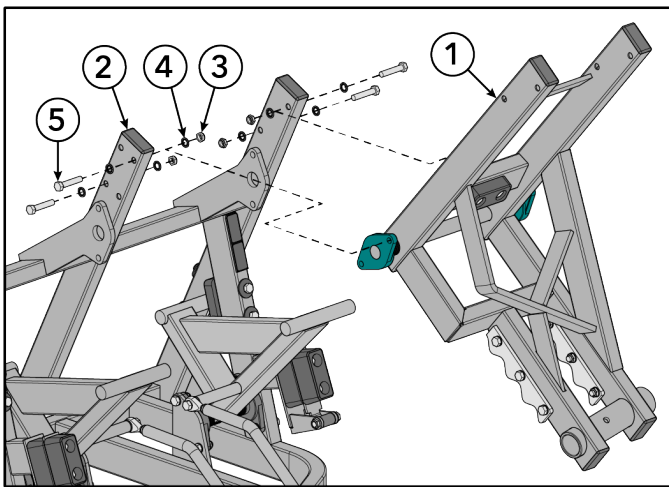

Item	Description	Qty.
1	Workarm Assembly	1
2	Main Frame Assembly	1
3	Nut, 1/2" Thin Lock	4
4	Washer, 1/2" Internal Lock	8
5	Bolt, HHB.5x2.5	4

CAUTION: Do not place hands between workarm assembly and main frame assembly during removal process.

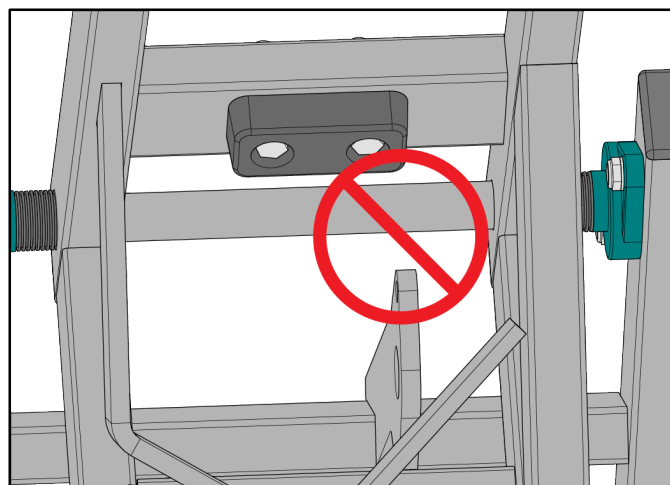

5. Repeat Steps 1-4 to remove opposite workarm assembly.

6. Tip unit onto side. Place furniture dollies in the locations shown below.

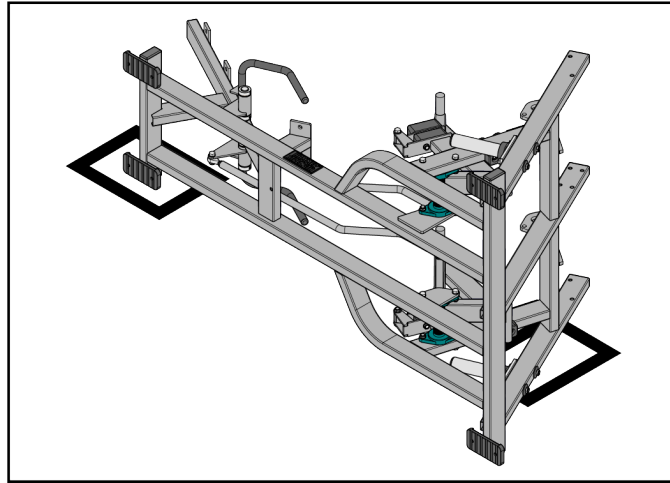

7. Fit components through doorway.

Option 1

NOTE: 56" / 142cm of clearance is needed on the exterior of one side of door frame.

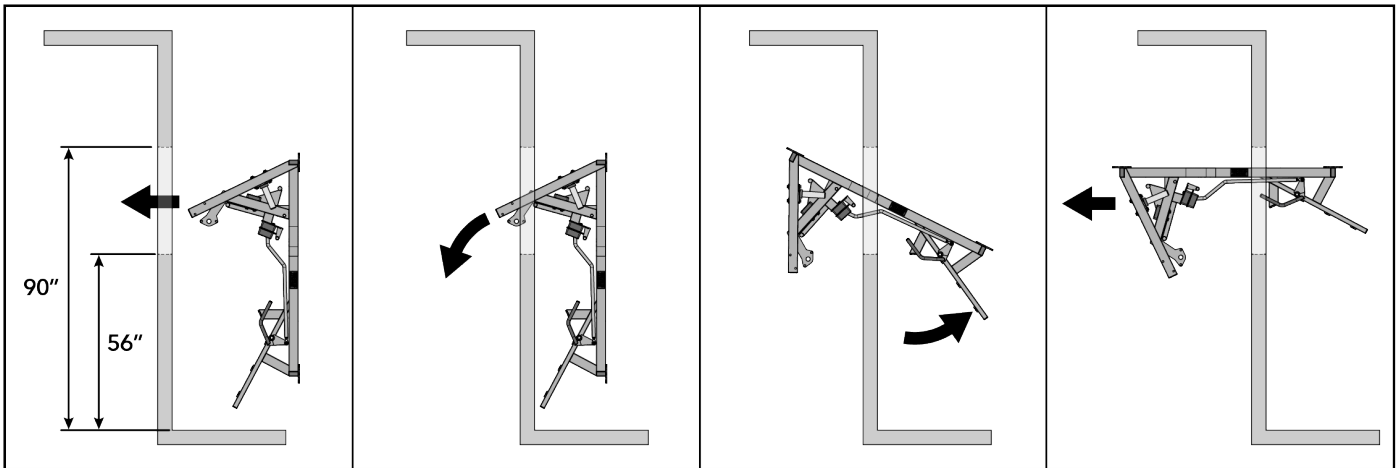

Option 2

NOTE: 52" / 132cm of clearance is needed on the interior of one side of door frame.

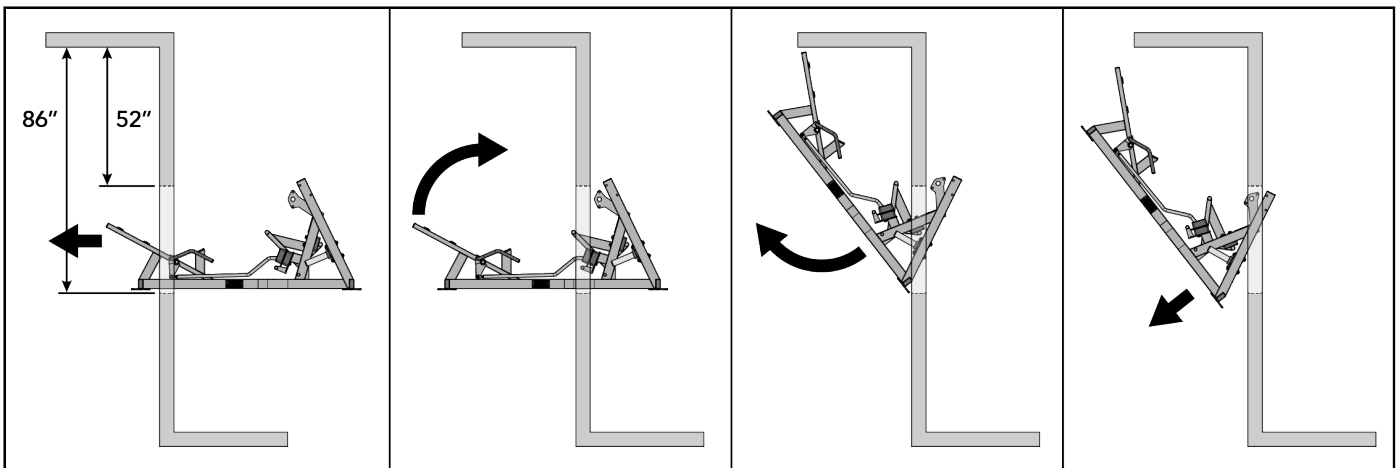

8. Tip unit upright.

9. Set rack-out assembly to furthest rear position.

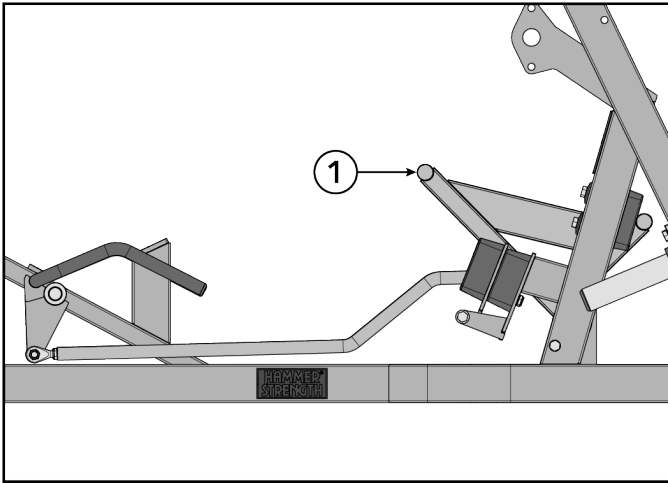

Item	Description	Qty.
1	Rack-Out Assembly	1

10. Install bolts, washers, and nuts securing workarm assembly to main frame assembly using two 3/4" wrenches.

NOTE: Set workarm assembly onto rack-out assembly bar to assist with installation.

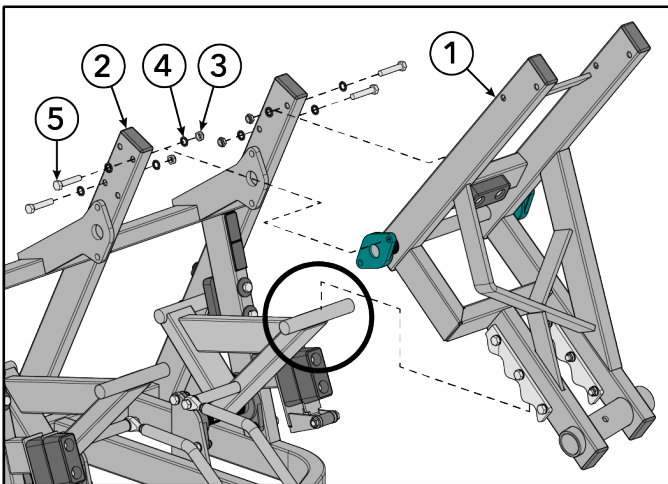

Item	Description	Qty.
1	Workarm Assembly	1
2	Main Frame Assembly	1
3	Nut, 1/2" Thin Lock	4
4	Washer, 1/2" Internal Lock	8
5	Bolt, HHB.5x2.5	4



Hand tighten hardware.

11. Install bolts, washers, and nuts securing link assembly and pillow block bearing to main frame assembly using two 3/4" wrenches.

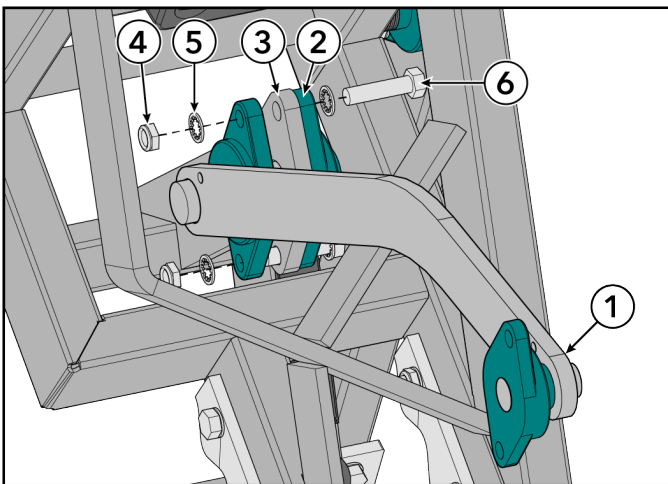

Item	Description	Qty.
1	Link Assembly	1
2	Pillow Block Bearing	1
3	Main Frame Assembly	1
4	Nut, 1/2" Thin Lock	2
5	Washer, 1/2" Internal Lock	4
6	Bolt, HHB.5x2	2



Hand tighten hardware.

12. Raise link assembly into position behind footplate assembly

13. Install bolts, washers, and nuts securing footplate assembly to workarm assembly using two 3/4" wrenches.

IMPORTANT: Footplate assembly must be centered in workarm assembly.

NOTE: Longer side (11.1" / 282mm) of footplate is oriented up.

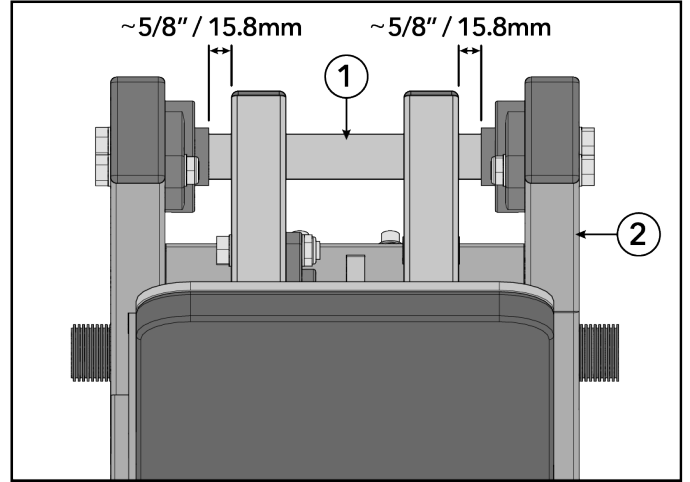
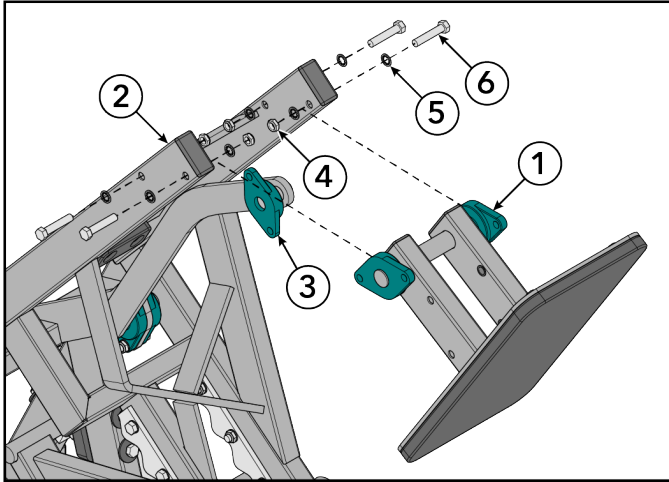

Item	Description	Qty.
1	Footplate Assembly	1
2	Workarm Assembly	1
3	Link Assembly	1
4	Nut, 1/2" Thin Lock	4
5	Washer, 1/2" Internal Lock	8
6	Bolt, HHB.5x2.5	4



Hand tighten hardware.

14. Install bolts, washers, and nuts securing link assembly to footplate assembly using two 3/4" wrenches.

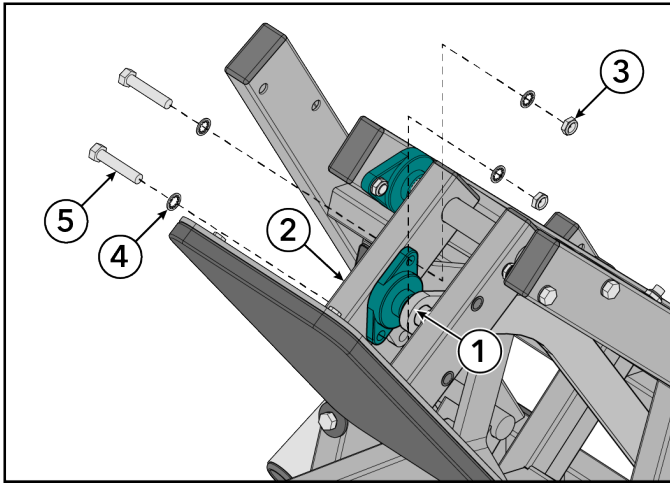

Item	Description	Qty.
1	Link Assembly	1
2	Footplate Assembly	1
3	Nut, 1/2" Thin Lock	2
4	Washer, 1/2" Internal Lock	4
5	Bolt, HHB.5x2.5	2



Hand tighten hardware.

IMPORTANT: Link assembly should be parallel between the footplate assembly. Link assembly or footplate assembly may need to be shifted left or right to achieve alignment.

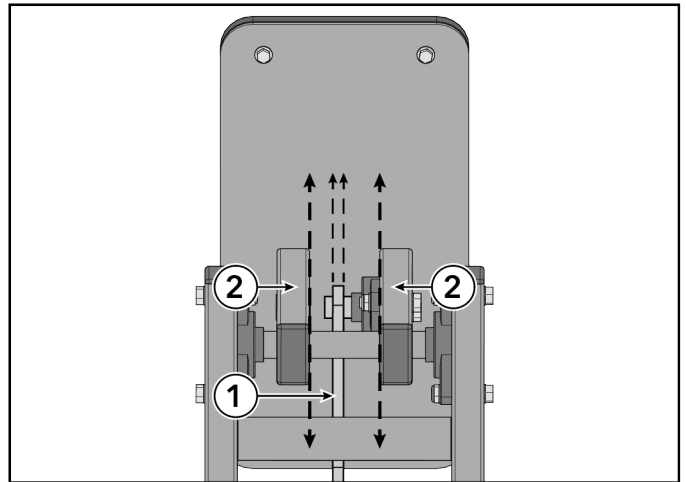
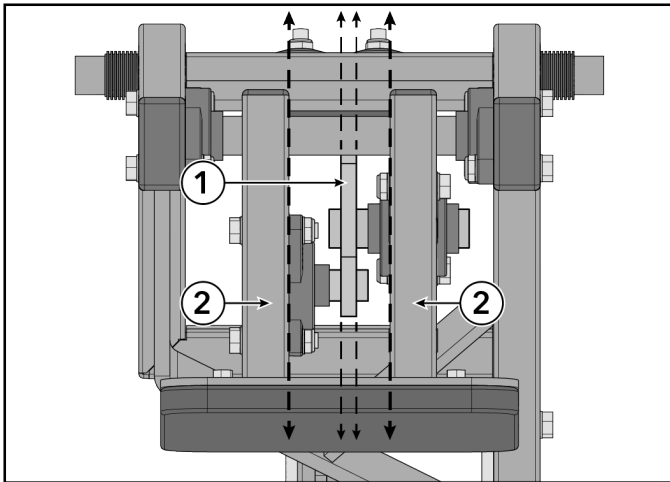

Item	Description	Qty.
1	Link Assembly	1
2	Footplate Assembly	1

15. Repeat Steps 9-14 to install left footplate assembly.

16. Tighten set screws in pillow block bearings to **40-50 in-lbs / 4.5-5.6 Nm**.

17. Tighten all loose hardware to **20-25 ft-lb / 27-34 Nm** in the following order:

- a. Workarm assembly to main frame assembly.
- b. Footplate assembly to workarm assembly
- c. Link assembly to main frame assembly.
- d. Link assembly to footplate assembly.

Install Pads

1. Install screws and washers securing back pad to main frame assembly using a 7mm Allen wrench.

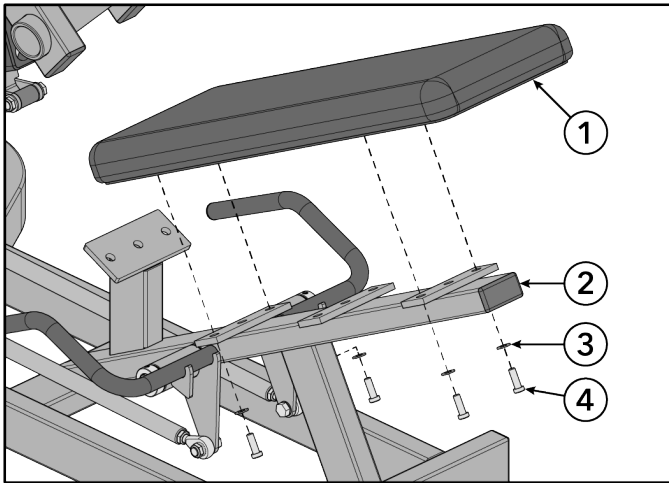

Item	Description	Qty.
1	Back Pad	1
2	Main Frame Assembly	1
3	Washer, 3/8" Flat	4
4	Screw, M10 x 1.5 30mm	4



Tighten hardware to 40-50 in-lb / 4.5-5.6 Nm.

2. Install screws and washers securing seat pad to main frame assembly using a 7mm Allen wrench.

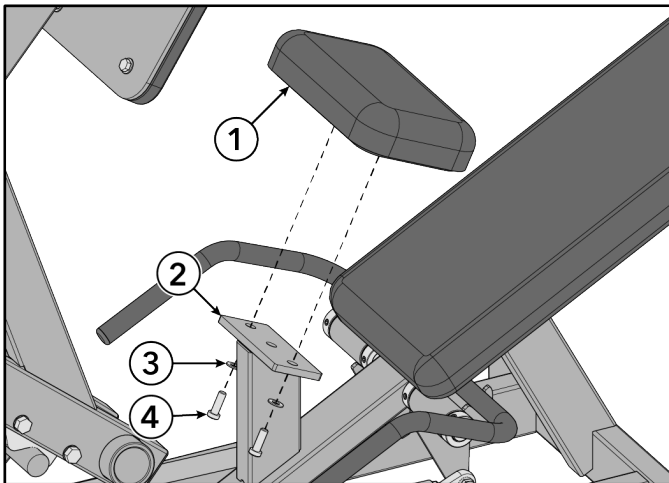

Item	Description	Qty.
1	Back Pad	1
2	Main Frame Assembly	1
3	Washer, 3/8" Flat	2
4	Screw, M10 x 1.5 30mm	2



Tighten hardware to 40-50 in-lb / 4.5-5.6 Nm.

Install Weight Horns

1. Install bolts, washers, and nuts securing weight tubes to workarm assemblies using two 3/4" wrenches.

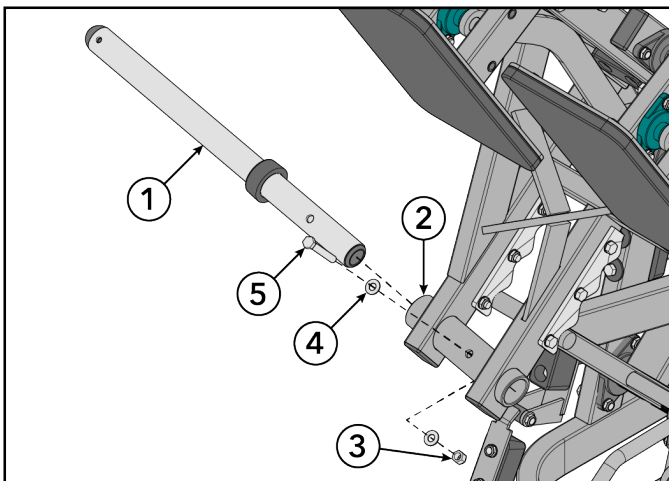

Item	Description	Qty.
1	Weight Tube	2
2	Workarm Assembly	2
3	Nut, 1/2" Thick Lock	2
4	Washer, 1/2" Flat	4
5	Bolt, HHB.5x3.5	2



Tighten hardware to 20-25 ft-lb / 27-34 Nm

- Remove bolts, washers, backing washers, and nuts securing weight horns to main frame assembly using two 3/4" wrenches.

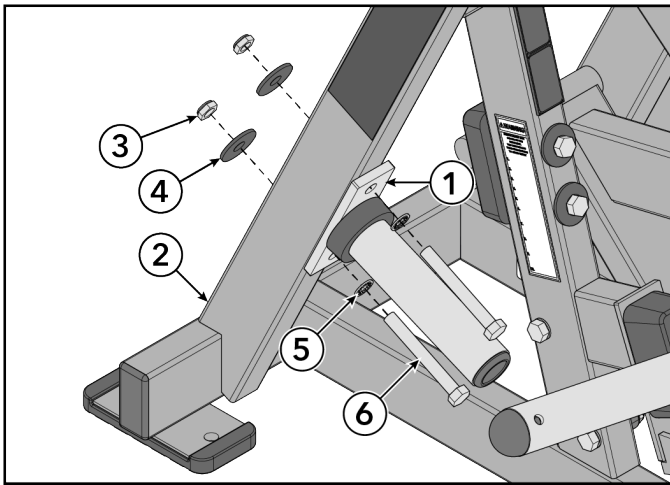

Item	Description	Qty.
1	Weight Horn	2
2	Main Frame Assembly	1
3	Nut, 1/2" Thin Lock	4
4	Backing Washer	4
5	Washer, 1/2" Internal Lock	4
6	Bolt, HHB.5x4	4

- Flip weight horns to opposite side.
- Install bolts, washers, backing washers, and nuts securing weight horns to main frame assembly using two 3/4" wrenches.

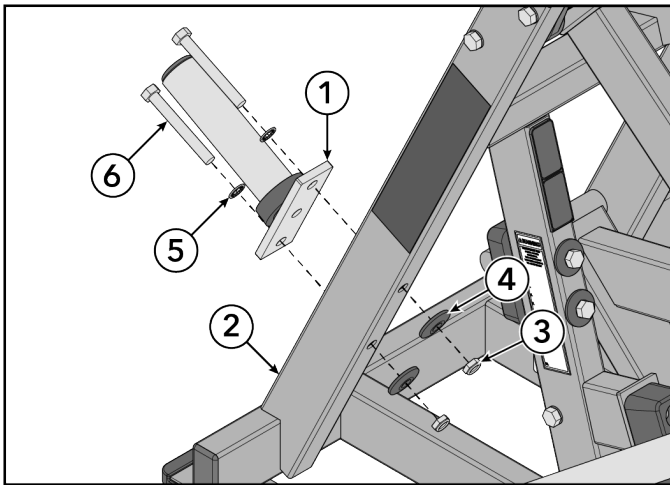

Item	Description	Qty.
1	Weight Tube	2
2	Workarm Assembly	2
3	Nut, 1/2" Thick Lock	2
4	Washer, 1/2" Flat	4
5	Bolt, HHB.5x3.5	2



Tighten hardware to 20-25 ft-lb / 27-34 Nm

Test Unit For Proper Operation

3. Product Information

Machine Weight:	lbs. = 570	kg. = 259
Max User Weight:	lbs. = 350	kg. = 158.8
Starting Resistance:	lbs. = 65 per leg	kg. = 29.5 kgs. per leg
Total Max Resistance:	lbs. = 850 (425 each side)	kg. = 385 (193 each side)
Max Plate Capacity*:	6-45 lb. plates (each side)	5-25 kg. plates (each side)
Size** (L x W x H):	in. = 88 x 69 x 62	cm = 223 x 175 x 158
Live Area*** (L x W x H):	in. = 112 x 93 x 74	cm = 283 x 236 x 188

NOTE: *Capacities listed are calculated using a thickness of 1-5/8" for 45lb weight plates and 48mm for 25 kg weight plates. If your facility uses thicker weight plates, the capacity may be reduced.

NOTE: **Dimensions are without weight plates.

NOTE: ***Live Area dimensions calculated and shown assuming a weight plate diameter of 46 cm.

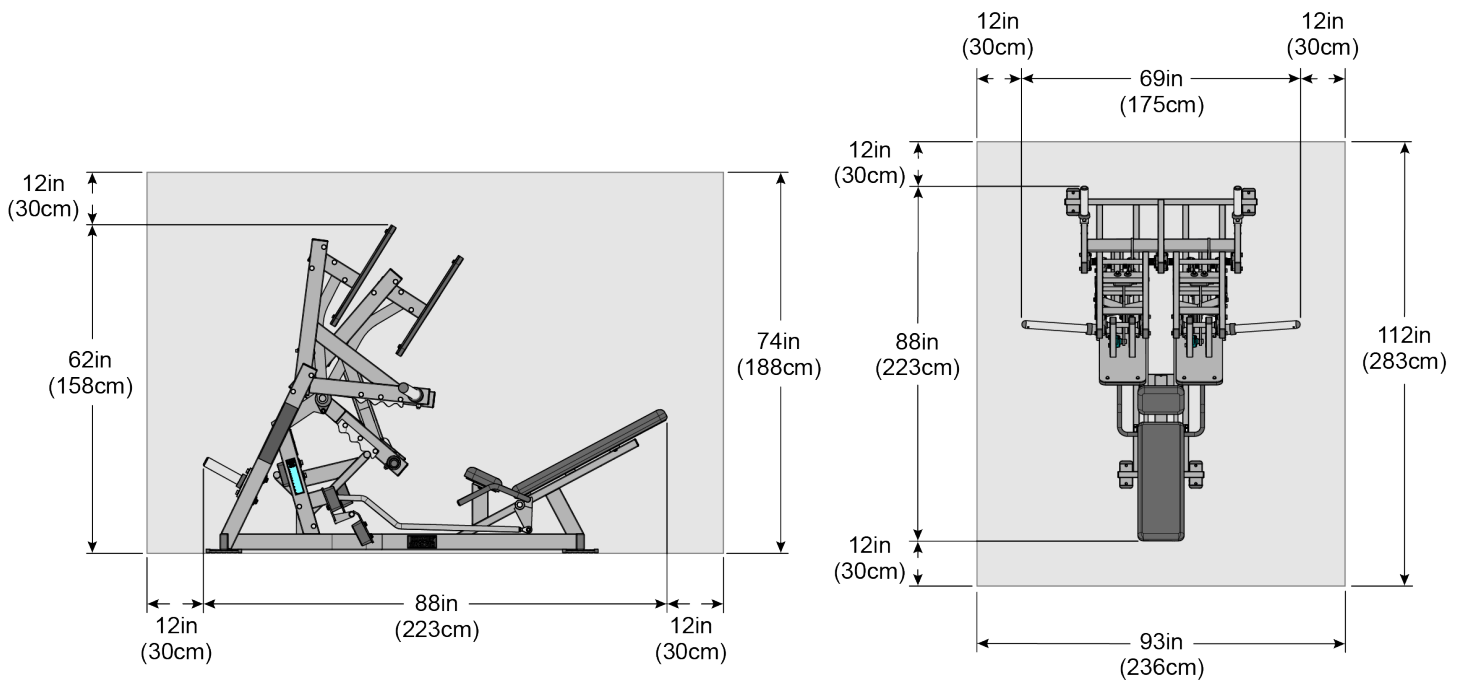

4. Bolt to Floor Guide

Introduction

Life Fitness designs its products to be stable when used as designed. Because strength training is dynamic, we cannot predict how users will ultimately use the products in all circumstances. Therefore, Life Fitness **recommends** that strength training equipment be secured to a solid, level surface to stabilize and eliminate rocking or tipping over.

Each new unit shipped comes with a multi-language hangtag stating the importance of bolting the unit down as a safety precaution.

It is the facility's responsibility to adhere to local and regional building codes.

Delivery and Installation Tips

All Anchors

- Fasteners must have minimum embedment in concrete floor, not including screed, regardless of wood/tile/rubber over sub-floor. (See *Anchor Types* for maximum sub-floor thickness between unit and concrete to equipment foot must be made of flooring or other material (i.e. no air gaps)).
- DO NOT reuse fasteners. Static and Dynamic anchors are designed for one-time use only.
- Factor in equipment's feet height when selecting fastener length.
- Factor in flooring thickness when selecting fastener length.
- It is also recommended to drill an additional 1/2" (12.7 mm) of depth beyond the length of the fastener being used to ensure that debris does not block the entry of the anchor.
- Minimum concrete compressive strength: 3000 psi (20 N/mm²).

Anchoring

- All anchors must have a minimum embedment into concrete, regardless of wood/tile/rubber/screed over sub-floor.
- Dynamic anchors must have a minimum embedment depth in concrete to ensure maximum security and pull out force. See *Anchor Types* for embedment depth minimums.

Building Codes

It is the facility's responsibility to adhere to local and regional building codes. Please verify with the customer to ensure that they are aware of this.

Carpeting

If bolted down to carpet flooring, be sure to use a box cutter knife to cut the carpet threads around each foot. This will help avoid the carpet threads from being wrapped around and pulled by the drill bit.

Competitor Product

The bolt down guidelines and procedures for Life Fitness products were determined by the company's Engineering and Installation Development groups. These guidelines include which anchors to use and positioning of the anchors are required for Life Fitness product.

- Life Fitness does not have that level of specification or engineering input for competitive product.
- Life Fitness installation teams are not permitted to anchor competitor equipment.

Drilling

It is also recommended to drill an additional 1/2" (12.7 mm) of depth beyond the length of the fastener being used to ensure that debris does not block the entry of the anchor.

- This can be done by marking your drill bit with a piece of tape.
- While it is recommended that a vacuum be used to clean up debris, this will not account for all the debris that will settle at the bottom of the drilled hole.

Anchor Type - Static

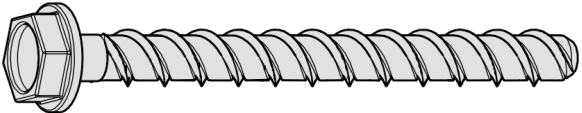
Static Anchor	Standard Sizes	Drill Bit Size
	Imperial: KH-EZ 3/8" x 5"	3/8in
	Metric: HUS-H 10mm x 130mm	10mm

Anchor Specifications

Static Anchor	Minimum Concrete Thickness	Minimum Drill Depth in Concrete	Minimum Concrete Embedment	Minimum concrete compressive strength
KH-EZ 1/4"	4-1/8" (105mm)	1/2" (12.7mm) beyond anchor length	2-1/2" (63.5mm)	3000psi (20 N/mm ²)
HUS-H 6mm	3-3/32" (100mm)	25/64" (10mm) beyond anchor length	2-1/64" (55mm)	3000psi (20 N/mm ²)

Pullout Force

Life Fitness specifies Hilti™ static and dynamic anchors. According to the anchor manufacturer, the recommended design pullout force (in tension) for the specified anchors, when properly installed in cracked concrete, is provided in the side table. This table should be used for reference only; for additional and up-to-date information on the anchor capabilities or the design pullout force in other substrates, please consult Hilti directly at <https://www.us.hilti.com>.

Selected Anchor	Design Resistance in Tension *
KH-EZ 1/4" x 4"	830 lb
HUS-H 6MM x 120MM	3.3 kN
KH-EZ 3/8" x 4"	1535 lb
KH-EZ 3/8" x 5"	1535 lb
HUS-H 8MM x 120MM	3.3 kN
HUS-H 8MM x 150MM	3.3 kN
HSL-3 and HSL4 M 8/40	2000 lb
HST M12 x 115/20	8 kN
HST M12 x 195/200	8 kN
KB-TZ 3/8" x 3-3/4"	1615 lb

* Design strength extracted from the Hilti Anchor Fastening Technology Manual.

Tools Required

⚠ WARNING: Adhere to manufacturer's equipment warnings and guidelines. Follow manufacturer's instructions for proper usage.

- 1" L-shape SDS rotary hammer
- (Imperial anchors) 3/8" diameter carbide drill bit
- (Metric anchors) 10mm diameter carbide drill bit
- Extension cord
- Floor scanner / rebar detector (optional)
- Hammer (Dynamic anchors only)
- Rotary tool
- Safety glasses
- Tape measure
- Torque wrench
- Vacuum (for debris)

Static Anchor

- Floor scanner / rebar detector (optional)
- 1" L-shape SDS rotary hammer
- 1/4" x 12" / 6 mm x 305 mm carbide drill bit (for 1/4" (6mm) anchors)
- 3/8" x 12" / 8 mm x 305 mm carbide drill bit (for 3/8" (8mm) anchors)
- Safety glasses

- Extension cord
- Impact wrench
- Vacuum (for debris)

Static Anchor Procedure

⚠ **CAUTION:** If it is possible that the length of your bolt will not provide the minimum requirement of 2.5" (63.5mm) of engagement, a longer anchor should be used.

1. Place unit into position to be mounted and cycle unit to set stance.
2. Each foot **must** get at least one static fastener.
3. Wearing protective glasses, drill down into the flooring to the required depth as perpendicular as possible, ensuring that the foot thickness is being accounted for; refer to *Anchor Selection* and *Foot Dimensions*.

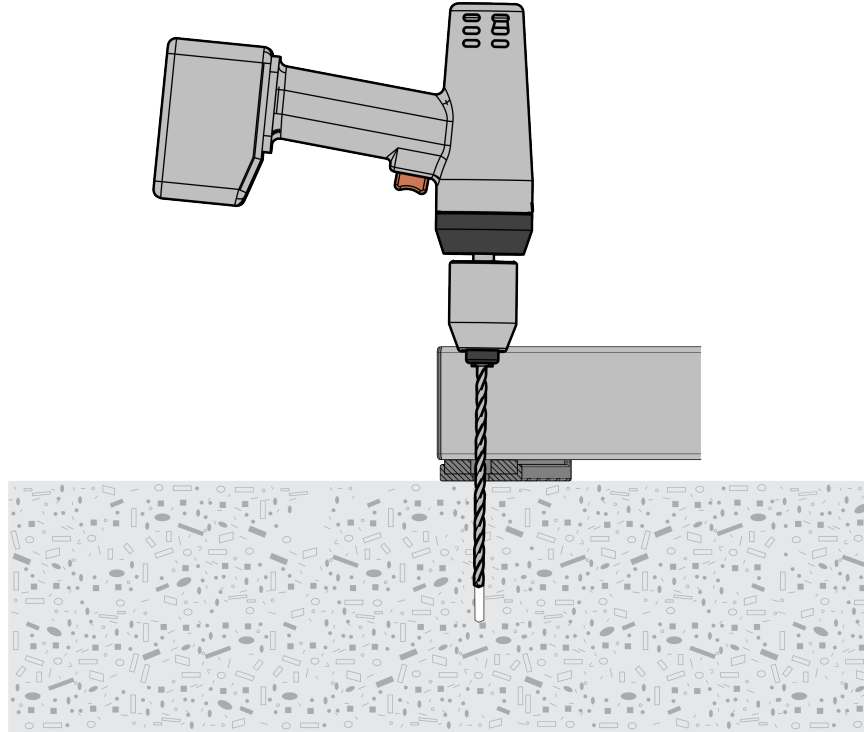

4. Insert fastener and tighten to 18 Foot-Pounds (24Nm) for 1/4" (6mm) anchor or 40 Foot-Pounds (54Nm) for 3/8" (8mm) anchor.

NOTE: If the legs/frame do not contact the mounting surface **DO NOT** pull down with the fastener or anchor. Loosen frame hardware and re-tighten to allow machine to align.

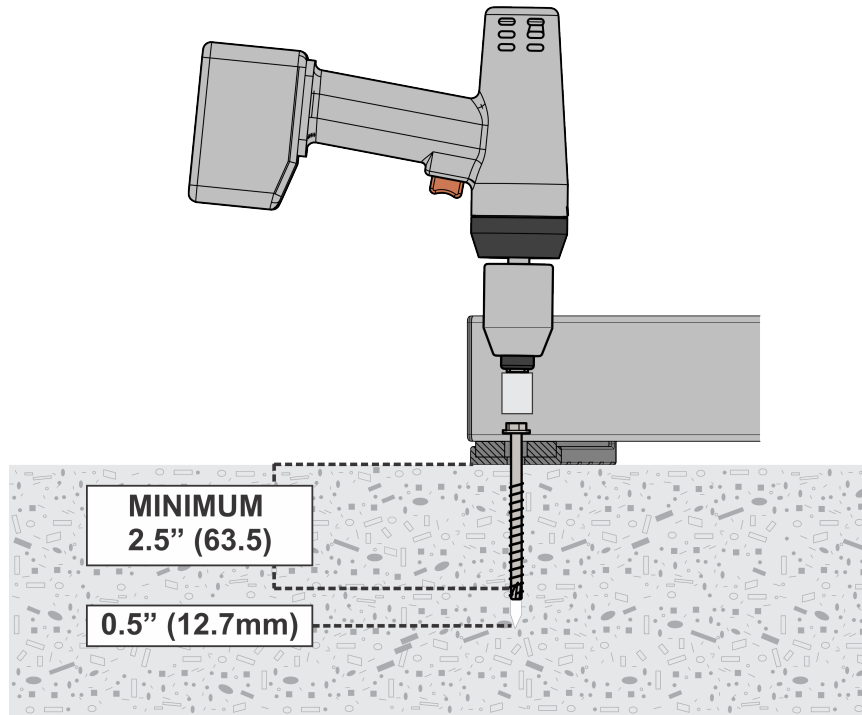

Foot Dimensions

Use below image to determine foot height thickness.

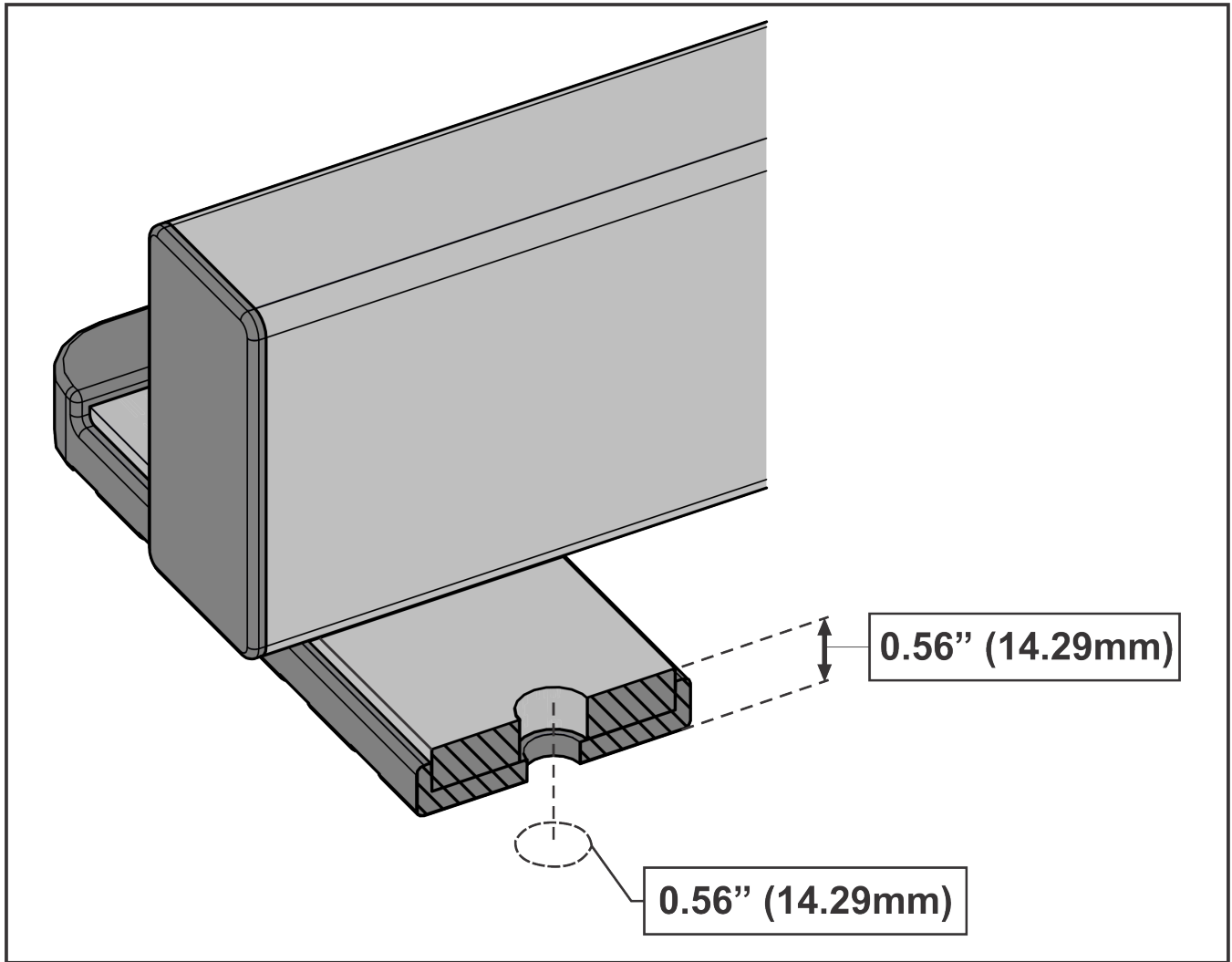

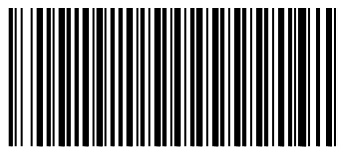

1028243-0001