

Axiom Series Single and Dual Stations

Owner's Manual



Corporate Headquarters

Columbia Centre III, 9525 Bryn Mawr Avenue, Rosemont, Illinois 60018 • U.S.A.
847.288.3300 • FAX: 847.288.3703
Service phone number: 800.351.3737 (toll-free within U.S.A., Canada)
Global Website: www.lifefitness.com

International Offices

AMERICAS

North America

Life Fitness, LLC

Columbia Centre III
9525 Bryn Mawr Avenue
Rosemont, IL 60018 U.S.A.
Telephone: (847) 288 3300
Service Email:
customersupport@lifefitness.com
Sales/Marketing Email:
commercialsales@lifefitness.com

Brazil

Life Fitness Brasil

Av. Rebouças, 2315
Pinheiros
São Paulo, SP 05401-300
BRAZIL
SAC: 0800 773 8282 option 2
Telephone: +55 (11) 3095 5200 option 2
Service Email: suportebr@lifefitness.com
Sales/Marketing Email:
vendasbr@lifefitness.com

Latin America and Caribbean*

Life Fitness, LLC

Columbia Centre III
9525 Bryn Mawr Avenue
Rosemont, IL 60018 U.S.A.
Telephone: (847) 288 3300
Service Email:
customersupport@lifefitness.com
Sales/Marketing Email:
commercialsales@lifefitness.com

EUROPE, MIDDLE EAST, and AFRICA (EMEA)

Netherlands and Luxemburg

Life Fitness Atlantic BV

Bijdorpplein 25-31
2992 LB Barendrecht
THE NETHERLANDS
Telephone: (+31) 180 646 666
Service Email:
service.benelux@lifefitness.com
Sales/Marketing Email:
marketing.benelux@lifefitness.com

United Kingdom

Life Fitness UK LTD

Queen Adelaide
Ely, Cambs, CB7 4UB
Telephone: General Office (+44)
1353.666017
Customer Support (+44) 1353.665507
Service Email: uk.support@lifefitness.com
Sales/Marketing Email: life@lifefitness.com

Germany, Austria, and Switzerland

Life Fitness Europe GMBH

Neuhofweg 9
85716 Unterschleißheim
GERMANY
Telephone:
+49 (0) 89 / 31775166 Germany
+43 (0) 1 / 6157198 Austria
+41 (0) 848 / 000901 Switzerland
Service Email:
kundendienst@lifefitness.com
Sales/Marketing Email:
vertrieb@lifefitness.com

Spain

Life Fitness IBERIA

C/Frederic Mompou 5,1ª^a
08960 Sant Just Desvern Barcelona
SPAIN
Telephone: (+34) 93.672.4660
Service Email:
servicio.tecnico@lifefitness.com
Sales/Marketing Email:
info.iberia@lifefitness.com

Belgium

Life Fitness Benelux NV

Parc Industriel de Petit-Rechain
4800 Verviers
BELGIUM
Telephone: (+32) 87 300 942
Service Email:
service.benelux@lifefitness.com
Sales/Marketing Email:
marketing.benelux@lifefitness.com

All Other EMEA Countries and Distributor Business EMEA*

Bijdorpplein 25-31
2992 LB Barendrecht
THE NETHERLANDS
Telephone: (+31) 180 646 644
Service Email:
EMEAServiceSupport@lifefitness.com

ASIA PACIFIC (AP)

Japan

Life Fitness Japan, Ltd

4-17-33 Minami Aoyama 1F/B1F
Minato-ku - Tokyo 107-0062
Japan
Telephone: (+81) 0120.114.482
Fax: (+81) 03-5770-5059
Service Email: service.lfj@lifefitness.com
Sales/Marketing Email:
sales@lifefitnessjapan.com

Hong Kong

Life Fitness Asia Pacific LTD

32/F, Global Trade Square
21 Wong Chuk Hang Road
Hong Kong
Telephone: (+852) 2575.6262
Service Email: Service.HK@lifefitness.com
Sales/Marketing Email:
hongkong.sales@lifefitness.com

All Other Asia Pacific countries and distributor business Asia Pacific*

32/F, Global Trade Square
21 Wong Chuk Hang Road
Hong Kong
Telephone: (+852) 2575.6262
Fax: (+852) 2575.6894
Service Email: Service.AP@lifefitness.com
Sales/Marketing Email:
Marketing.HK.Asia@lifefitness.com

*Also check www.lifefitness.com for local representation or distributor/dealer

User and Service Documents Link

<https://www.lftechsupport.com/web/document-library/documents>

Additional information is available online using the link above.

تتوفر معلومات إضافية على الإنترنت باستخدام الرابط أعلاه.

点击上面的链接可在线获取更多信息。

Flere oplysninger er tilgængelige online gennem linket ovenfor.

Bijkomende informatie is online beschikbaar via bovenstaande link.

Vous trouverez plus d'informations en ligne à l'aide du lien ci-dessus.

Zusätzliche Informationen finden Sie online über den oben angegebenen Link.

Ulteriori informazioni sono disponibili online utilizzando il link sopra riportato.

追加情報は上記リンクを使用してオンラインで利用可能です。

상기 링크를 통해 온라인에서 추가 정보를 볼 수 있습니다.

Informações adicionais estão disponíveis on-line, através do link acima.

Дополнительная информация доступна в интернете по ссылке, указанной выше.

Mediante el enlace anterior podrá acceder a información adicional en línea.

Ytterligare information finns online genom att använda länken ovan.

İnternet üzerinden daha fazla bilgi edinmek için yukarıdaki bağlantıyı kullanabilirsiniz.

هناك معلومات إضافية متاحة على الإنترنت باستخدام الرابط أعلاه.

Informazio osagarria eskuragarri dago goiko estekaren bidez.

Допълнителна информация можете да намерите онлайн, като използвате връзката по-горе.

Mitjançant l'enllaç anterior podreu accedir a informació addicional en línia.

使用上面的連結線上提供額外資訊。

Dodatne informacije možete pronaći na internetu sljedeći vezu iznad.

ከላይ የተቀመጠውን አገናኝ(ሊንክ) በመጠቀም መረጃዎች አንላይን ያገኛሉ።

Lisätietoja on saatavissa verkosta käyttämällä yllä olevaa linkkiä.

Wubetumi anya nsem afoforo aka ho wo websait so denam asem a ewa atifi ho a wubemia so so.

Πρόσθετες πληροφορίες είναι διαθέσιμες ονλάιν χρησιμοποιώντας το σύνδεσμο παραπάνω.

מידע נוסף זמין באינטרנט באמצעות הקישור לעיל.

További információ elérhető online, a fenti hivatkozás segítségével.

Viðbótarupplýsingar eru fáanlegar á netinu með því að smella á tengilinn hér fyrir ofan.

Plus indicium per superum situm potes invenire.

മുകളിലുള്ള ലിങ്ക് ഉപയോഗിച്ച് ഓൺലൈനിൽ കൂടുതൽ വിവരങ്ങൾ ലഭ്യമാണ്.

Ytterligere informasjon er tilgjengelig på nettet via linken ovenfor.

Dodatkowe informacje są dostępne online pod powyższym odnośnikiem.

Informações adicionais estão disponíveis online a usar o link acima.

Informații suplimentare sunt disponibile online, utilizând link-ul de mai sus.

Dodatne informacije dostupne su na mreži putem gornjeg linka.

Ďalšie informácie sú dostupné online na vyššie uvedenom odkaze.

Table of Contents

Safety

Safety Information.....	4
Product Labels.....	6
Label Locations.....	7
Single Stations.....	7
Dual Stations.....	17

Product Information

Single Stations.....	25
Dual Stations.....	35

Exercise

General Exercise Information.....	43
Single Stations.....	44
Dual Stations.....	54

Maintenance Procedures

Maintenance Schedule.....	62
---------------------------	----

Warranty

What is Covered.....	64
Who is Covered.....	64
Who Pays Transportation and Insurance For Service.....	64
What We Will Do To Correct Covered Defects.....	64
What is Not Covered.....	64
Owner's Manual.....	64
Exclusive Warranty.....	64
Changes in Warranty Not Authorized.....	64
Effects of State Laws.....	64
Warranty Coverage.....	64

Cable Handling Guide

Cable Terminations, Tensioning and Wear Guide.....	66
Cable Terminations.....	66
Tensioning Cable.....	67
Strength Cable Wear Guide.....	68

Life Fitness® is a registered trademark.

Gym Wipes® is a registered trademark of the 2XL Corporation. PureGreen 24 is a trademark of Pure Green.

© Copyright 2020, Life Fitness, LLC. All Rights Reserved. Life Fitness, Hammer Strength, Cybex, ICG and SCIFIT are registered trademarks of Life Fitness, LLC and its affiliated companies and subsidiaries. Brunswick and related trademarks used under license from Brunswick Corporation. Disclaimer: Images and specifications are current as of the date of publication and are subject to change.

Columbia Center III - 9525 Bryn Mawr Ave., Rosemont, IL 60018 • 847-288-3300 •

www.lifefitness.com • 1014208-0001 AD • 2020

1. Safety

Safety Information

It is the sole responsibility of the purchaser of Life Fitness Family of Brands products to read the owner's manual and warning labels and instruct all individuals, whether they are the end user or supervising personnel, on proper usage of the equipment.

UNDERSTANDING EACH AND EVERY WARNING TO THE FULLEST IS IMPORTANT. IF ANY OF THESE WARNINGS ARE UNCLEAR, CONTACT Life Fitness Family of Brands CUSTOMER SERVICE IMMEDIATELY AT 1-800-351-3737.

This equipment is categorized as class S per EN ISO 20957-1. As such this equipment is only intended for commercial, institutional and/or studio facilities. It is not intended for home use. Contact Life Fitness Family of Brands with any questions regarding this classification.

It is recommended that all users of Life Fitness Family of Brands exercise equipment be informed of the following information prior to use.

Operating Warnings

 **WARNING:** This product can expose you to chemicals including Methyl Isobutyl Ketone, which is known to the State of California to cause cancer and birth defects or other reproductive harm. For more information go to <http://www.P65Warnings.ca.gov>

- It is the purchaser's sole responsibility to properly instruct its end users and supervising personnel as to the proper operating procedures of all equipment.
- This equipment is not intended for use by children. Keep children under the age of 13 away from the machine.
- Do not allow users to wear loose fitting clothing or jewelry while using equipment. It is also recommended to have users secure long hair back and up to avoid contact with moving parts.
- All bystanders must stay clear of all users, moving parts and attached accessories and components while machine is in operation.

Access Control

- Life Fitness Family of Brands recommends that all commercial fitness equipment be used in a supervised area. It is recommended that the equipment be located in an access controlled area. Control is the responsibility of the facility owner.

Installation

- Life Fitness Family of Brands recommends that all equipment be secured to a solid, level surface to stabilize it and eliminate rocking or tipping over. This must be performed by a licensed contractor. See [Bolt to Floor Guide](#) for installation procedure.

Proper Usage

- Do not use any equipment in any way other than as designed or intended by the manufacturer. It is imperative that Life Fitness Family of Brands equipment is used properly to avoid injury.
- Injuries may result if exercising improperly or excessively. It is recommended that all individuals consult a physician prior to commencing an exercise program. If at any time during exercise you feel faint, dizzy or experience pain, STOP EXERCISING and consult your physician.
- Keep body parts (hands, feet, hair, etc.), clothing and jewelry away from moving parts to avoid injury.
- When adjusting any seat, knee hold down pad, range of motion limiter, foothold pad, pulley or any other type of adjuster, make certain that the adjusting pin is fully engaged in the hole to avoid injury.

Inspection

- DO NOT attempt to use or repair any accessory approved for use with the equipment which appears to be damaged or worn.
- DO NOT use or permit use of any equipment that is damaged and/or has worn or broken parts. For all Life Fitness Family of Brands equipment, use only replacement parts supplied by Life Fitness Family of Brands.
- Cables and belts pose an extreme liability if used when damaged. Always replace any cable at first sign of wear (consult Life Fitness Family of Brands if uncertain).
- Maintain labels and name plates - Do not remove labels for any reason. They contain important information. If unreadable or missing, contact Life Fitness Family of Brands customer service for a replacement.
- Equipment Maintenance - Preventative maintenance is the key to smooth operating equipment as well as to keep your liability to a minimum. Equipment needs to be inspected at regular intervals.

- Ensure that any person(s) making adjustments or performing maintenance or repair of any kind is qualified to do so. Life Fitness Family of Brands will provide service and maintenance training at our corporate facility upon request or in the field if proper arrangements are made.
- Before use, examine all accessories approved for use with the Life Fitness Family of Brands equipment for damage or wear.

Selectorized

- Use only weight selector pins supplied by seller on weight stacks. Substitutes are forbidden.
- Fully insert weight selector pins. Partial insertion can cause weights to fall unexpectedly.
- Never pin the weight stack in an elevated position.
- Never remove selector pin if any weights are suspended.
- Never attempt to release jammed weights or parts.
- Never use dumbbells or other means to incrementally increase the weight resistance. Use only those means provided by seller.

Warnings and Cautions

- Warning labels indicate a potentially hazardous situation that could result in serious injury or death if the precautions are not observed.
- Caution labels indicate a potentially hazardous situation that could result in serious injury or damage to machine if the precautions are not observed.
- Contact [Customer Support Services](#) to replace any worn or damaged labels.

Product Labels



General Warning

WARNING

SERIOUS INJURY CAN OCCUR ON THIS EQUIPMENT. YOU MUST FOLLOW THESE PRECAUTIONS TO AVOID INJURY!

1. Before using, read all the warnings and obtain instruction on the use of this machine. Use only for intended exercise. **DO NOT** modify the machine.
2. Obtain a medical exam before beginning any exercise program.
3. Keep body, hair and clothing free of all moving objects.
4. Inspect machine and attachments before use. **DO NOT** use if the machine or attachments appear damaged. **DO NOT** attempt to fix broken or jammed machine or damaged attachments. Notify staff immediately.
5. Be certain that weight pin is completely inserted. Use only the pin provided by the manufacturer. If unsure, seek assistance.
6. Never pin the weights or prop plate into an elevated position. **DO NOT** use the machine if found in this condition. **DO NOT** attempt to fix. Seek assistance.
7. Inspect cables and their connections before using machine. **DO NOT** attempt to fix. Seek assistance.
8. Use only the incremental weights supplied by the manufacturer. **DO NOT** use dumbbells or other means to add resistance to the machine.
9. Children must not be allowed near this machine. Supervise teenagers.
10. Manufacturer recommends that all equipment be secured to the floor to stabilize and eliminate rocking or tipping over. Use a licensed contractor.
11. **DO NOT REMOVE THIS LABEL. REPLACE IF DAMAGED.**

Serial Number

LifeFitness  

9525 WEST BRYN MAWR AVE
ROSEMONT, IL 60018
USA 1-800-351-3737
CAGE Code: 0CMY5 EN ISO 20957 Class S
www.LifeFitness.com

Model: **XXX**
Made in Hungary
Max User Wt: **XXX**lbs **XXX**kgs
Max Training Wt: **XXX**lbs **XXX**kgs

SN: **XXXXXXXXXXXX**



Pinch Hazard



Row Handle

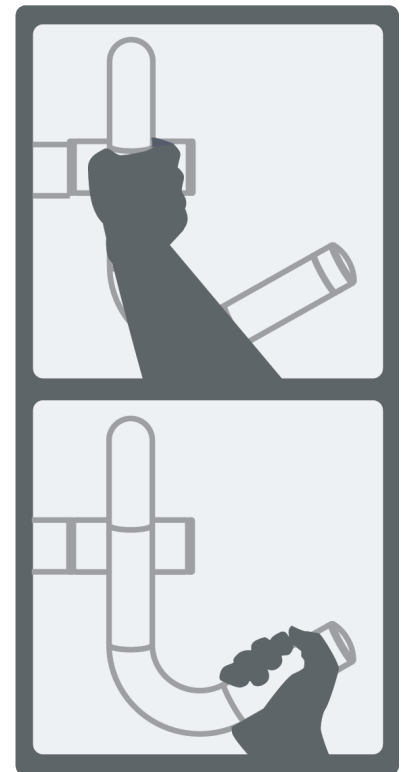

Label Locations
Single Stations
Abdominal (OP-AB)

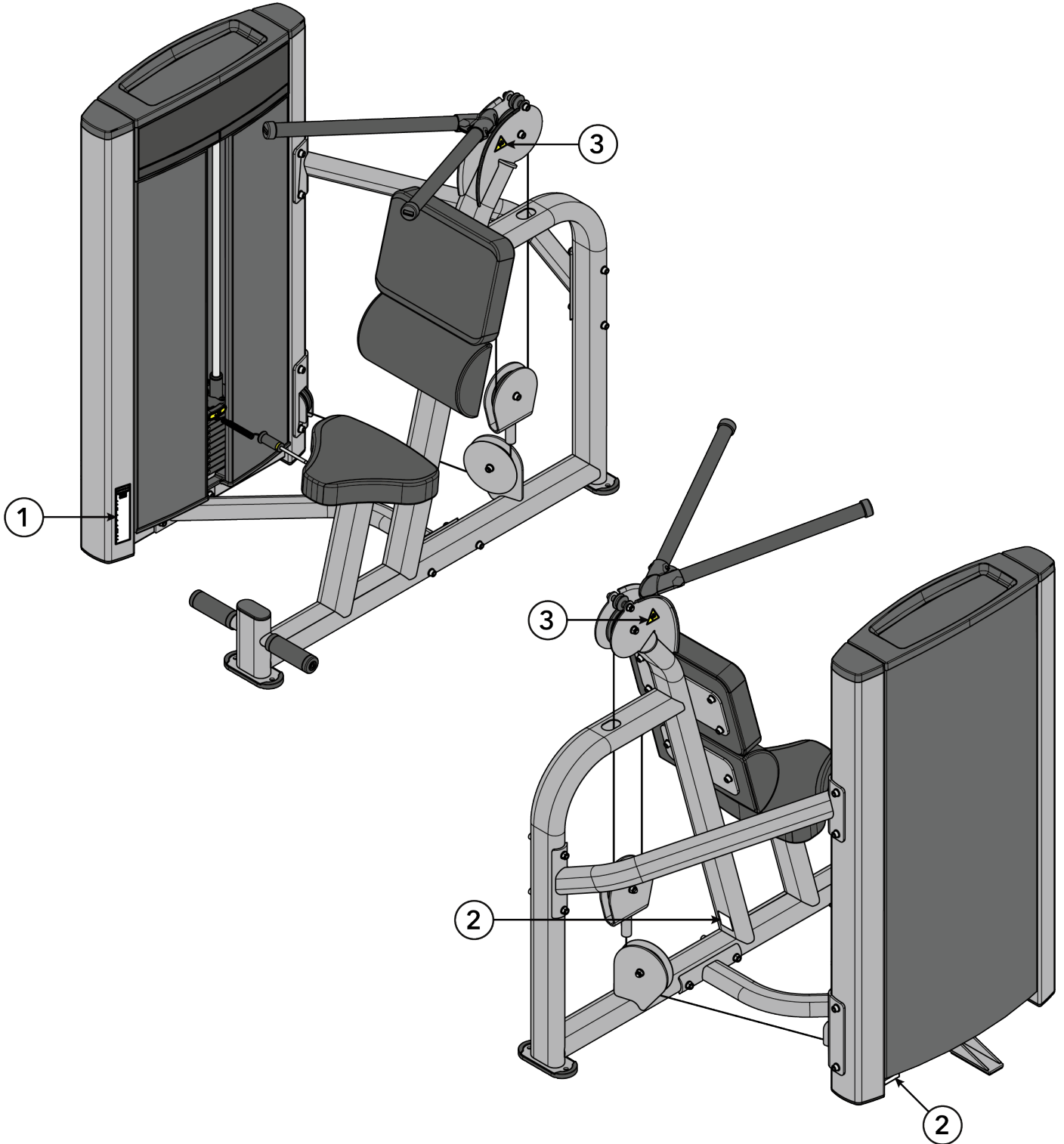

Item	Description	Qty.
1	General Warning	1
2	Serial Number	2
3	Pinch Hazard	2

Biceps Curl (OP-BC)

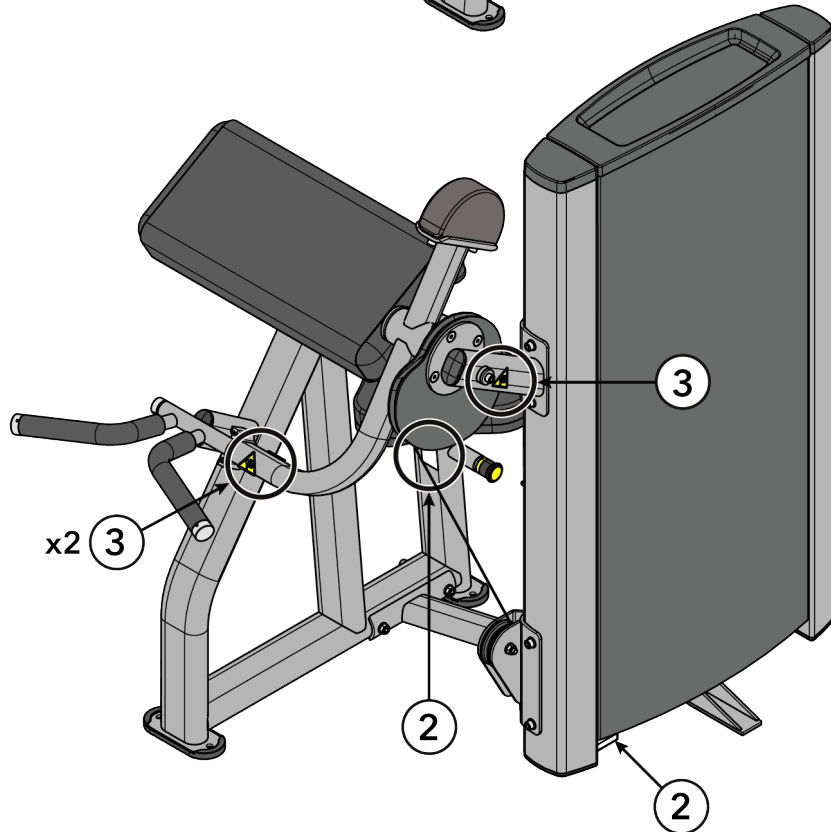
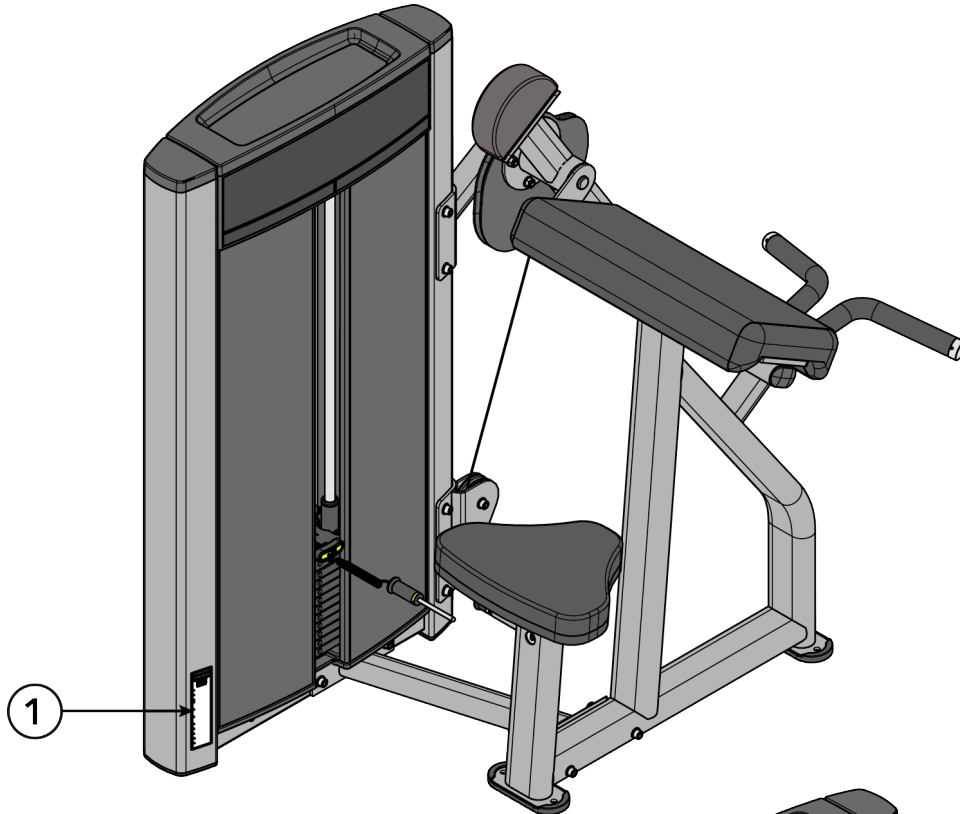

Item	Description	Qty.
1	General Warning	1
2	Serial Number	2
3	Pinch Hazard	3

Chest Press (OP-CP)

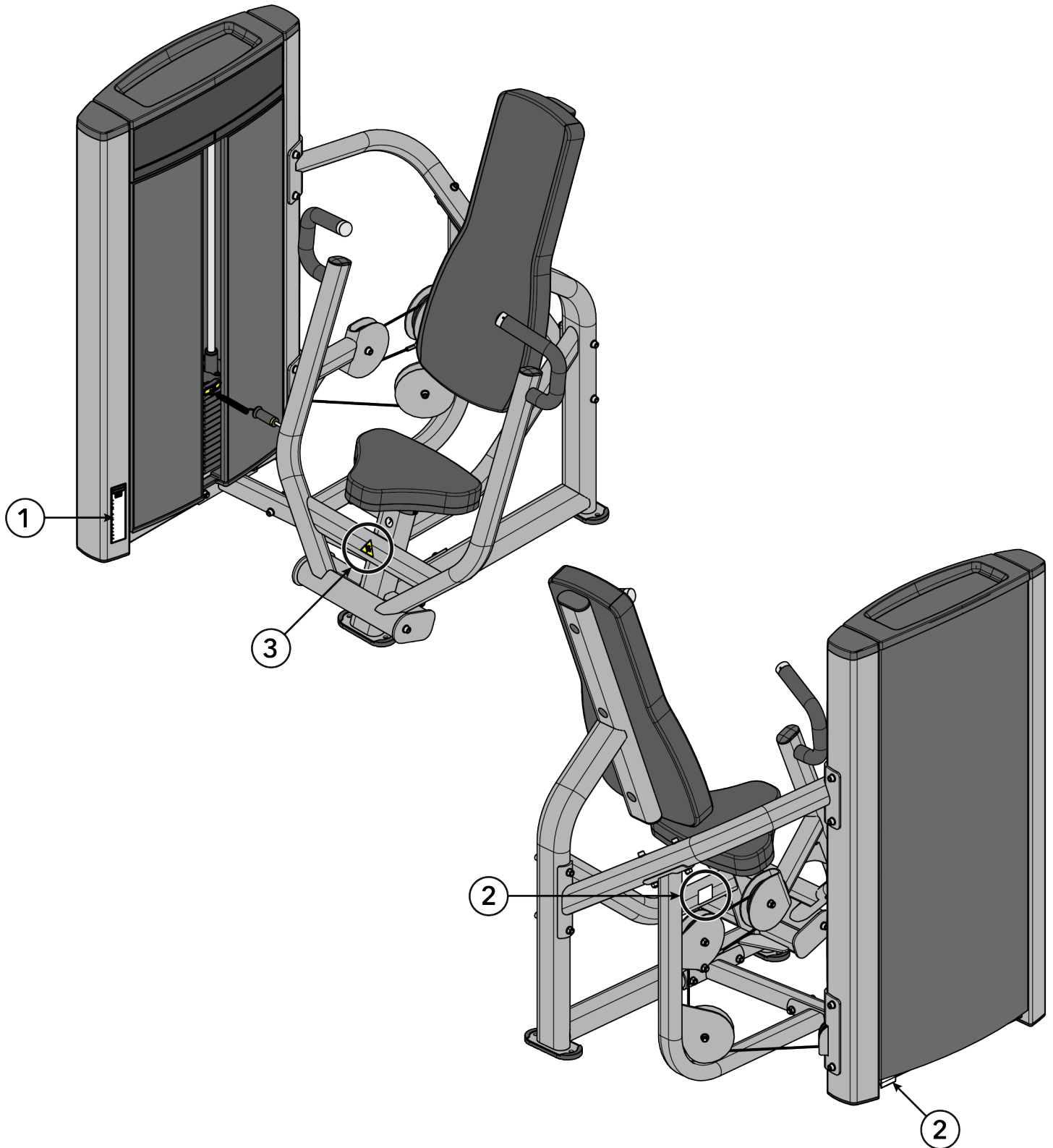

Item	Description	Qty.
1	General Warning	1
2	Serial Number	2
3	Pinch Hazard	1

Leg Curl (OP-LC)

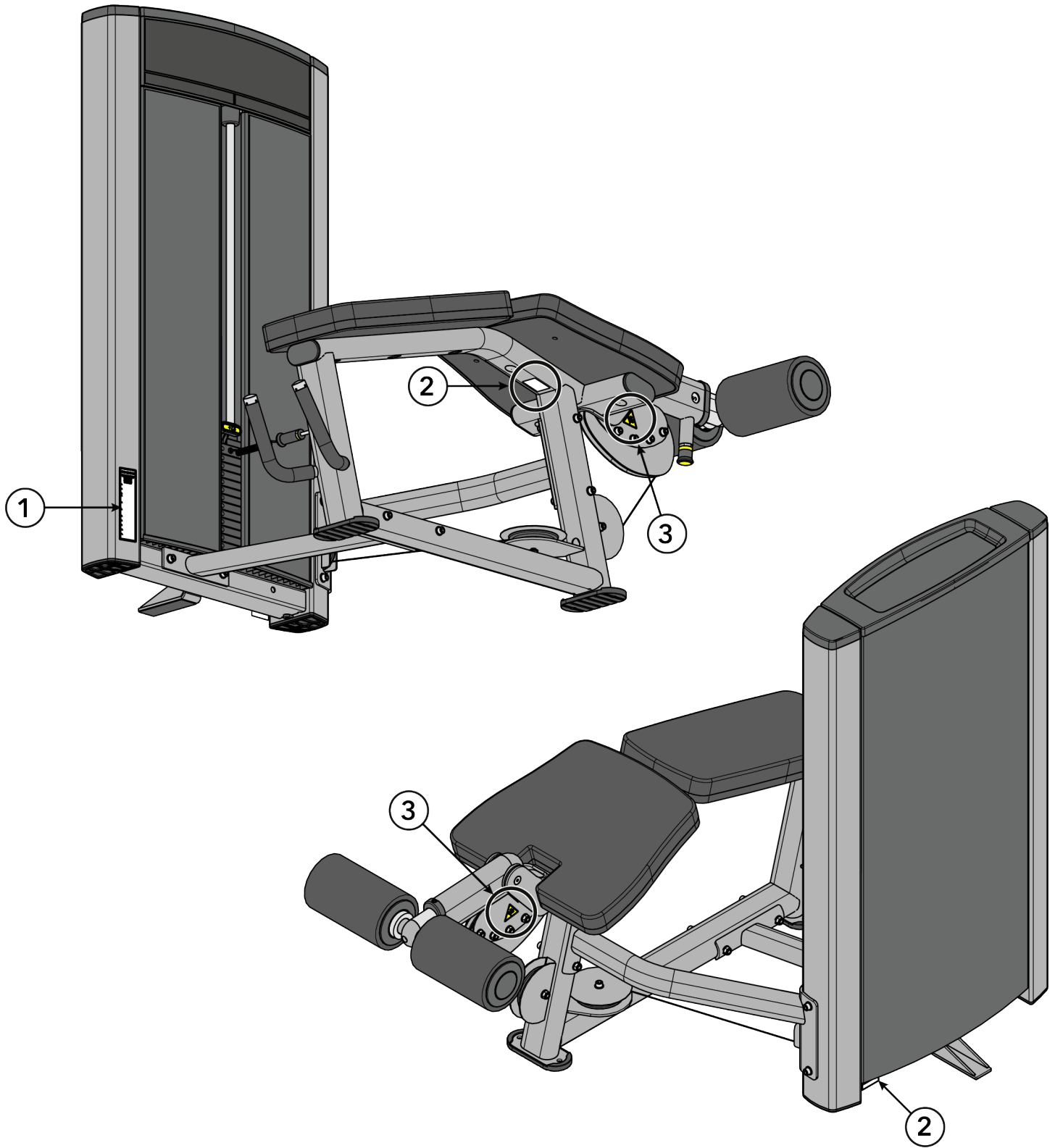

Item	Description	Qty.
1	General Warning	1
2	Serial Number	2
3	Pinch Hazard	2

Leg Extension (OP-LE)

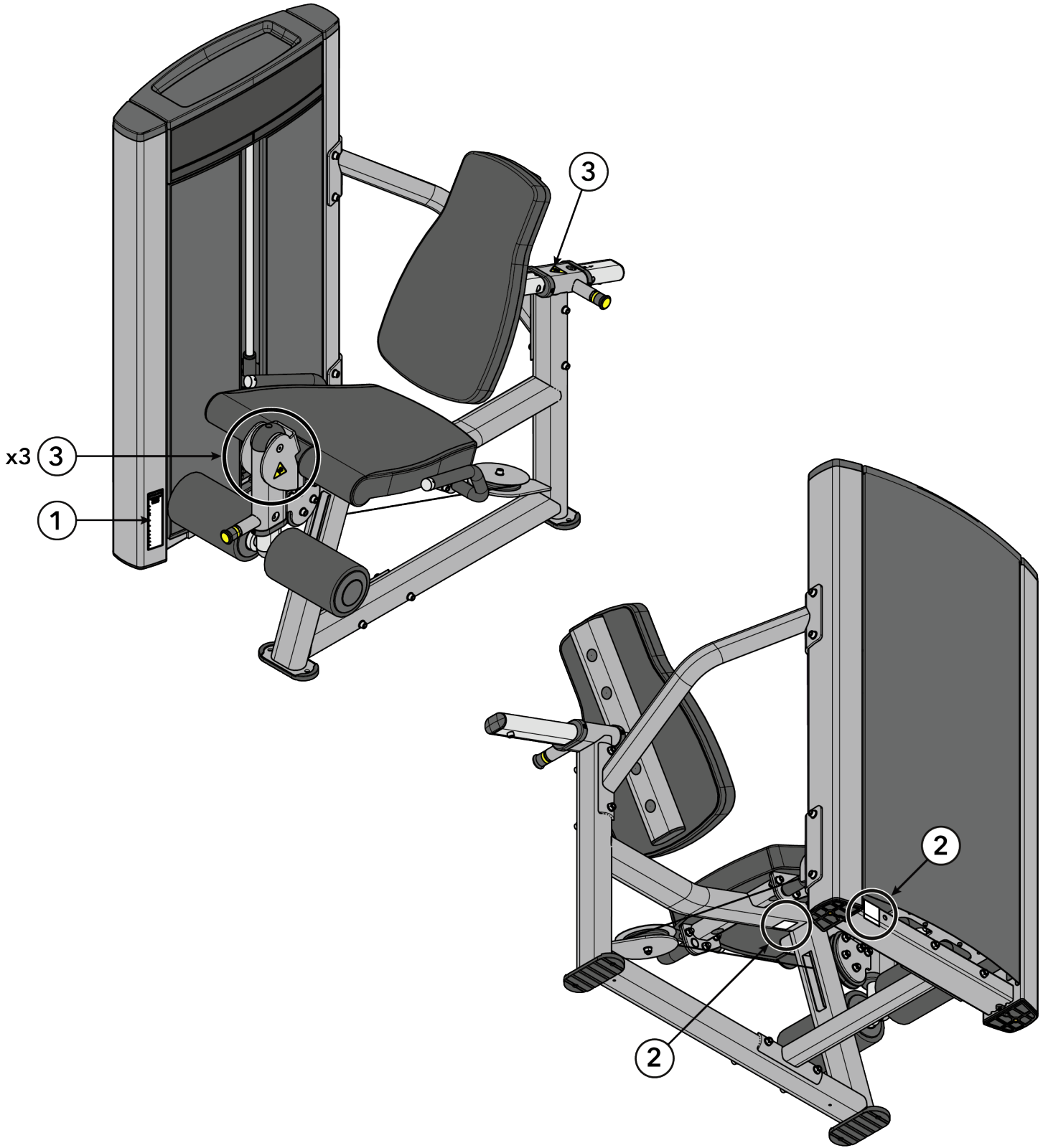

Item	Description	Qty.
1	General Warning	1
2	Serial Number	2
3	Pinch Hazard	4

Leg Press (OP-LP)

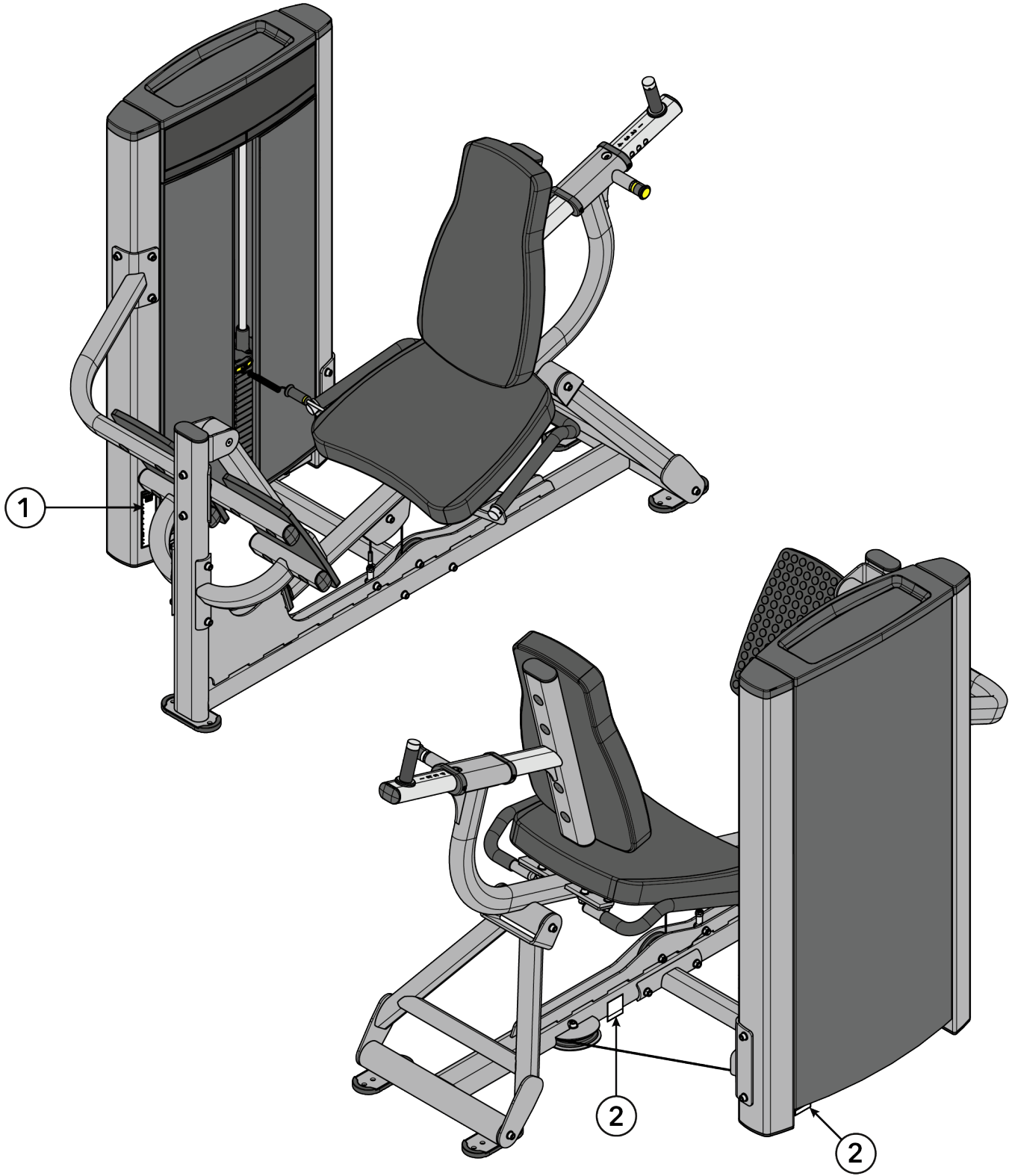

Item	Description	Qty.
1	General Warning	1
2	Serial Number	2

Pulldown (OP-PD)

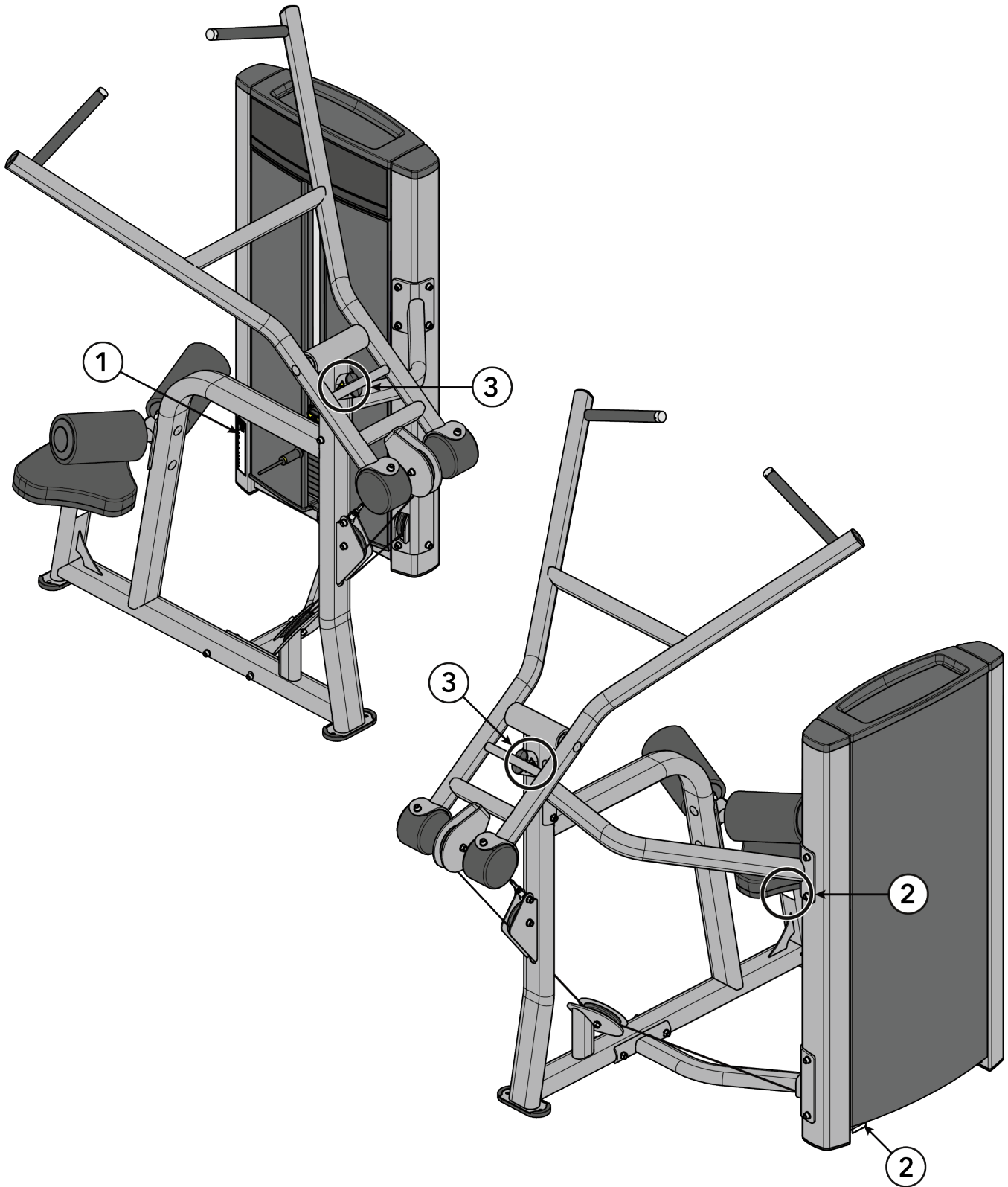

Item	Description	Qty.
1	General Warning	1
2	Serial Number	2
3	Pinch Hazard	2

Seated Row (OP-RW)

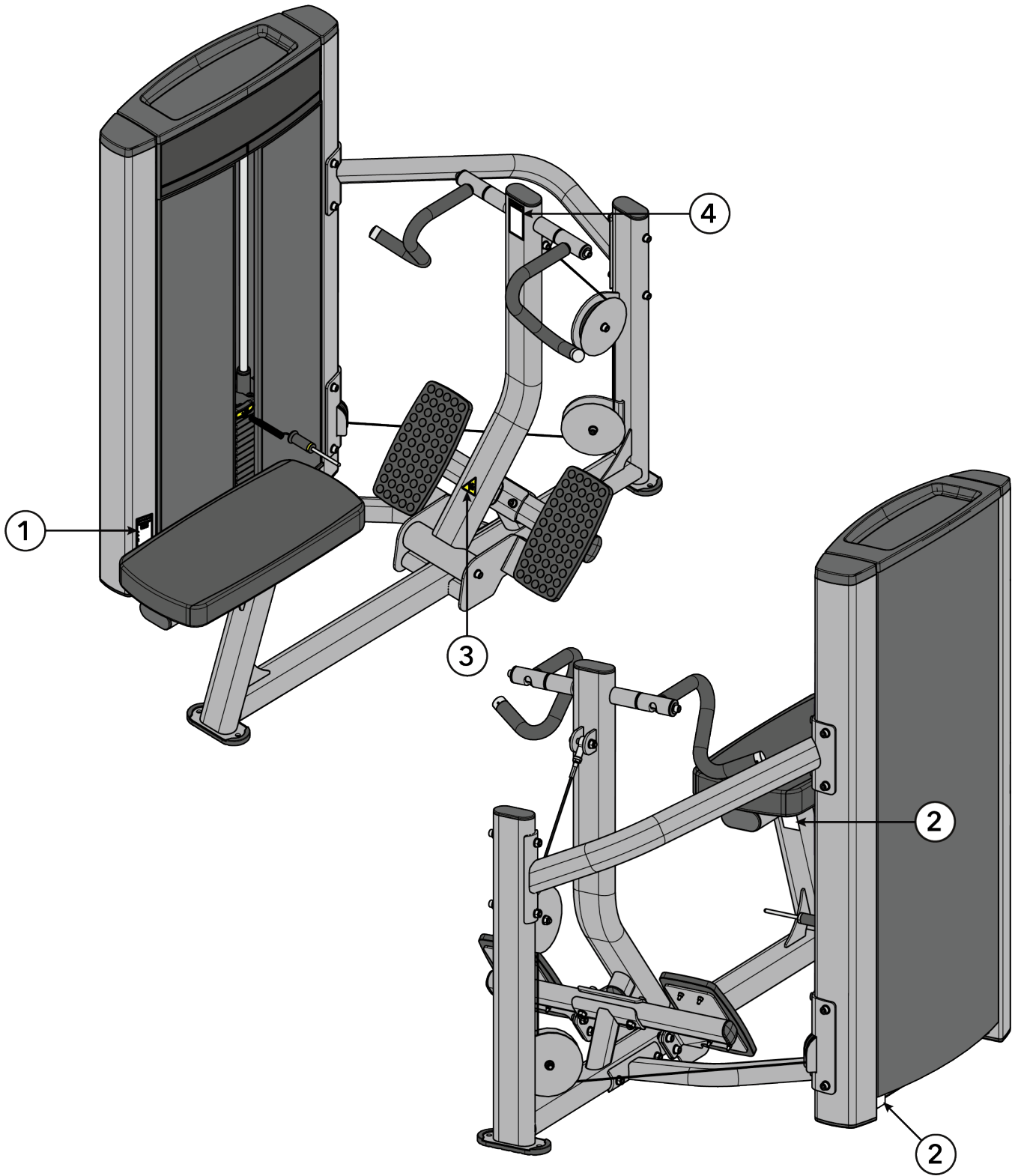

Item	Description	Qty.
1	General Warning	1
2	Serial Number	2
3	Pinch Hazard	1
4	Row Handle	1

Shoulder Press (OP-SP)

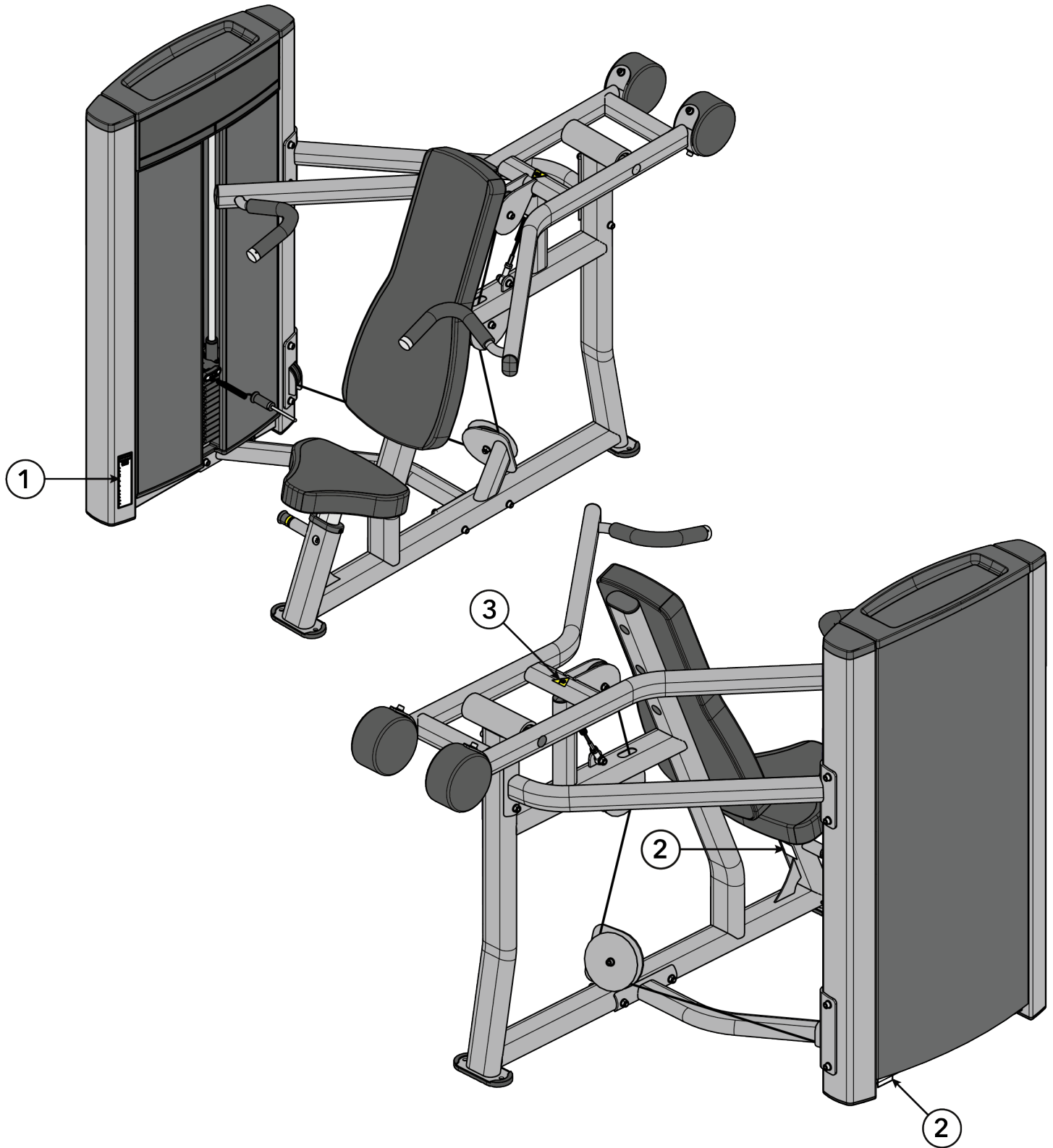

Item	Description	Qty.
1	General Warning	1
2	Serial Number	2
3	Pinch Hazard	1

Triceps Extension (OP-TE)

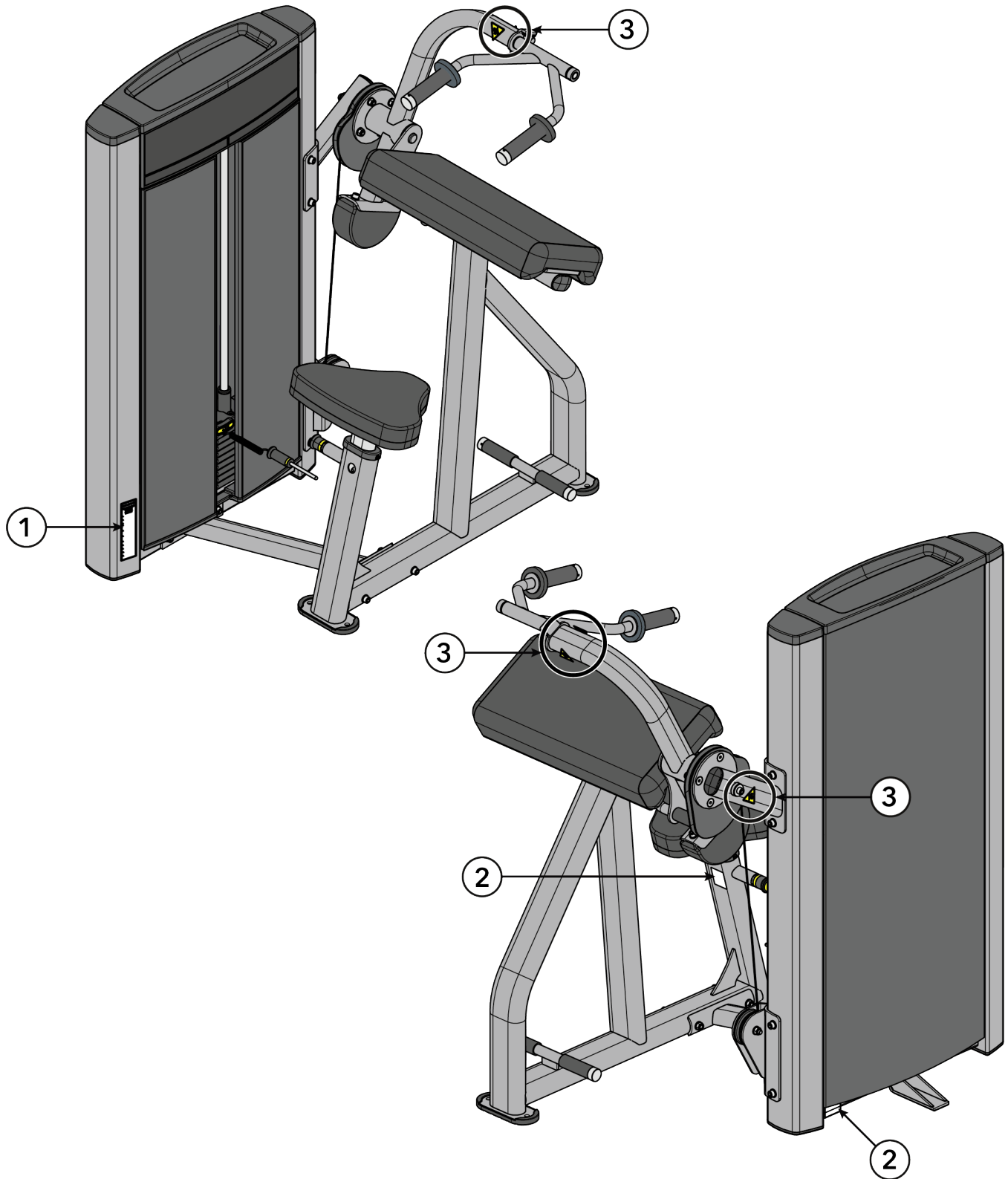

Item	Description	Qty.
1	General Warning	1
2	Serial Number	2
3	Pinch Hazard	3

Dual Stations

Abdominal / Back Extension (OP-ABBA)

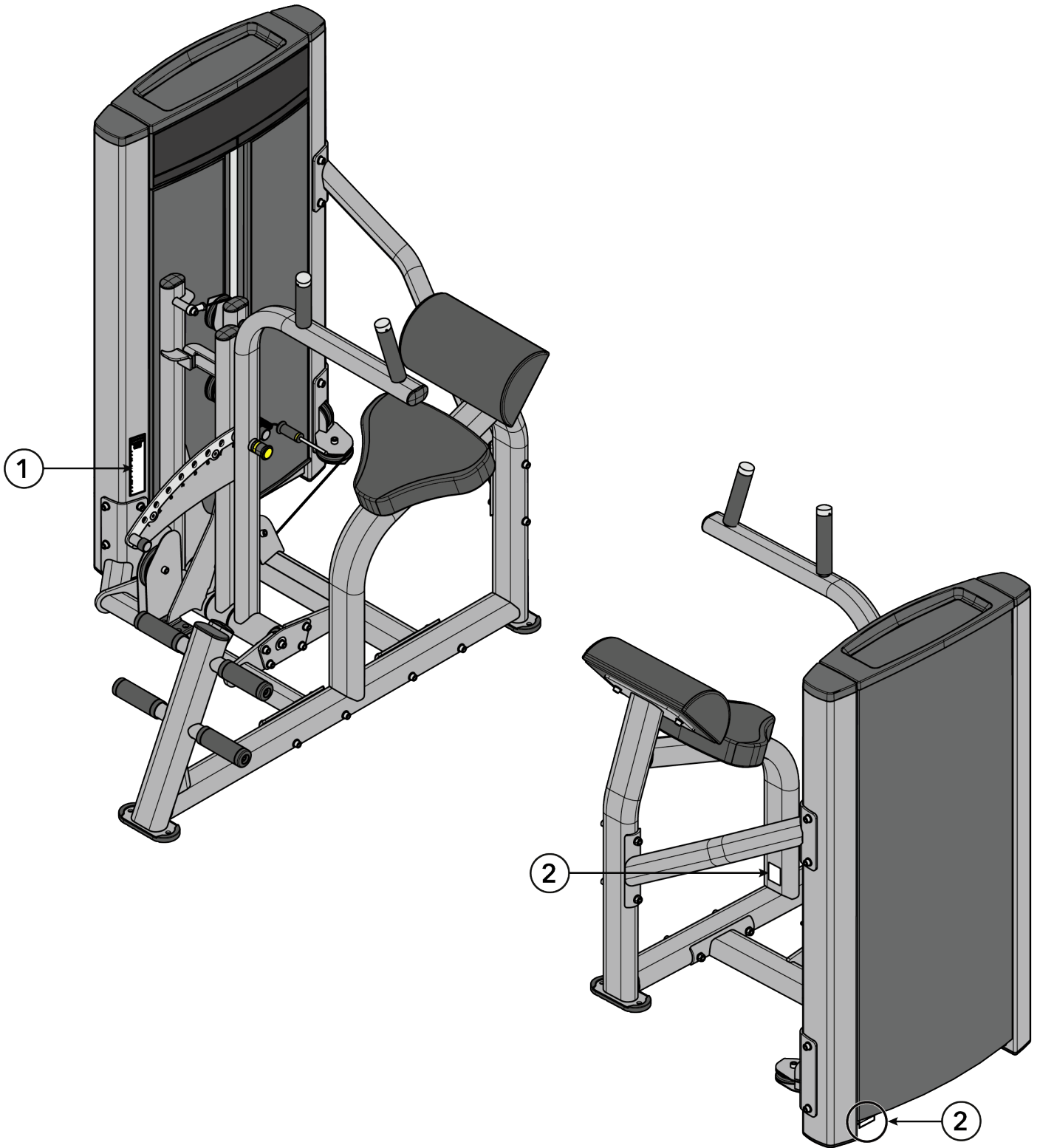

Item	Description	Qty.
1	General Warning	1
2	Serial Number	2

Biceps Curl / Triceps Extension (OP-BT)

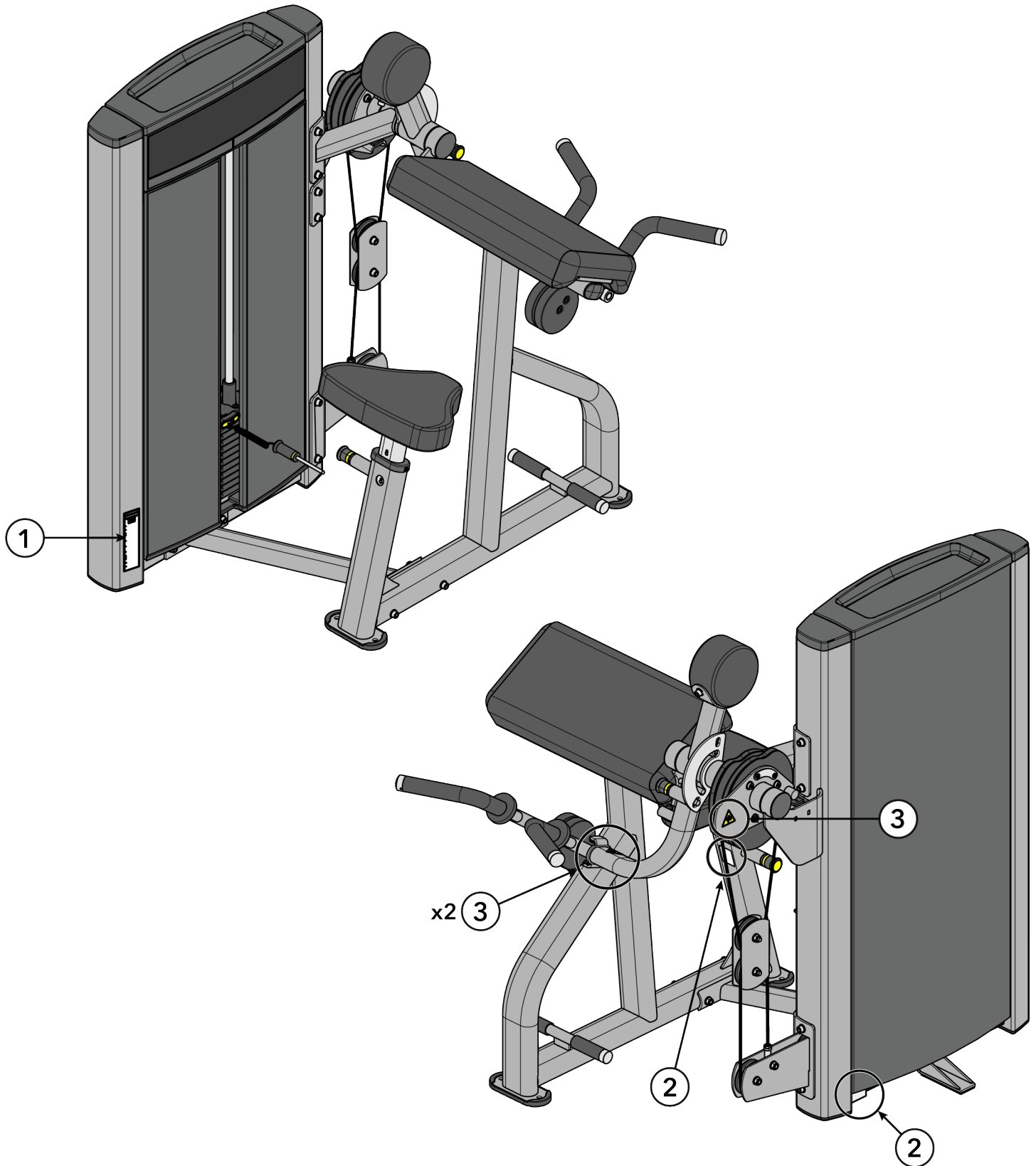

Item	Description	Qty.
1	General Warning	1
2	Serial Number	2
3	Pinch Hazard	3

Hip Abductor / Adductor (OP-HAA)

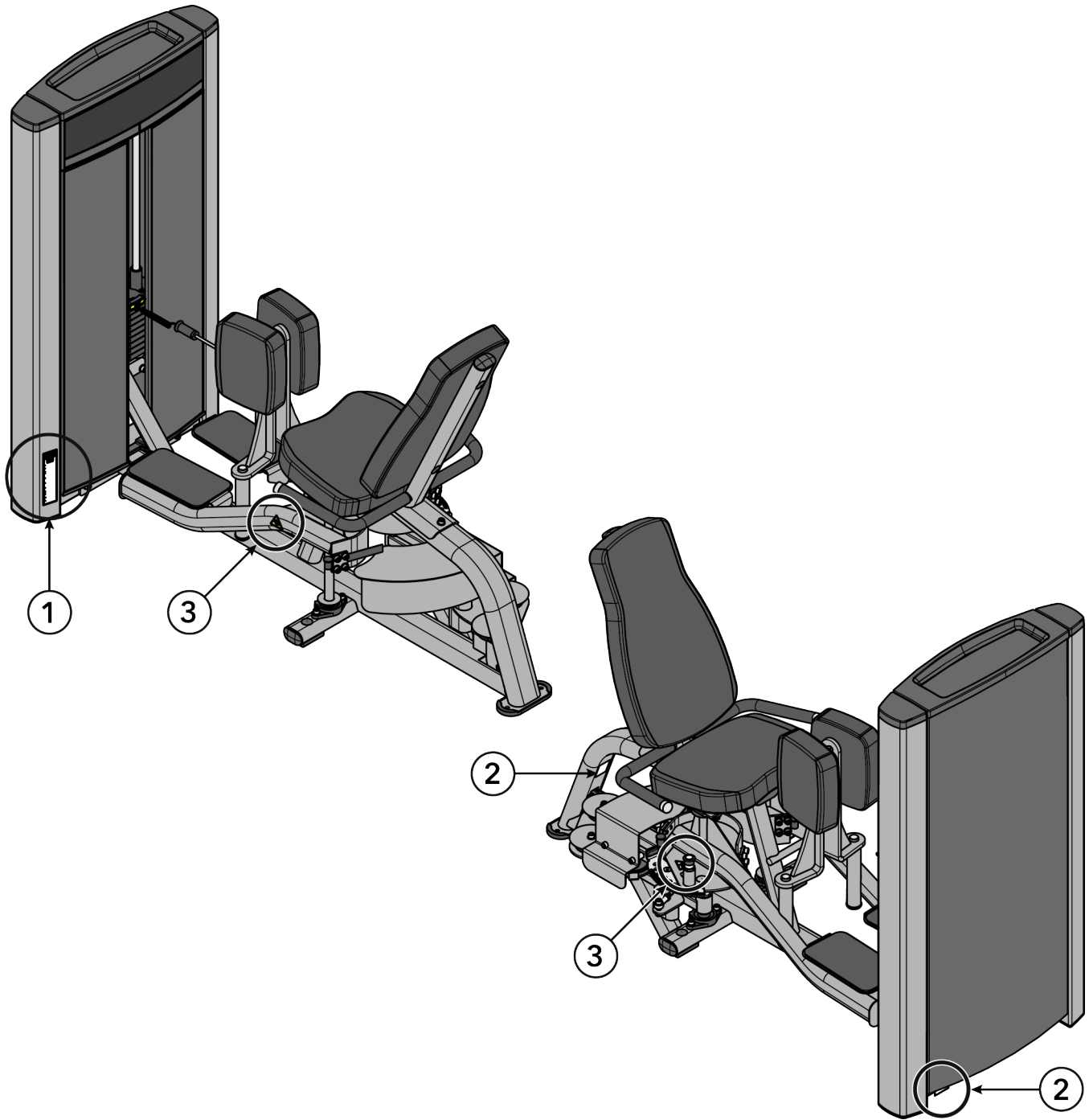

Item	Description	Qty.
1	General Warning	1
2	Serial Number	2
3	Pinch Hazard	2

Leg Curl / Extension (OP-LCE)

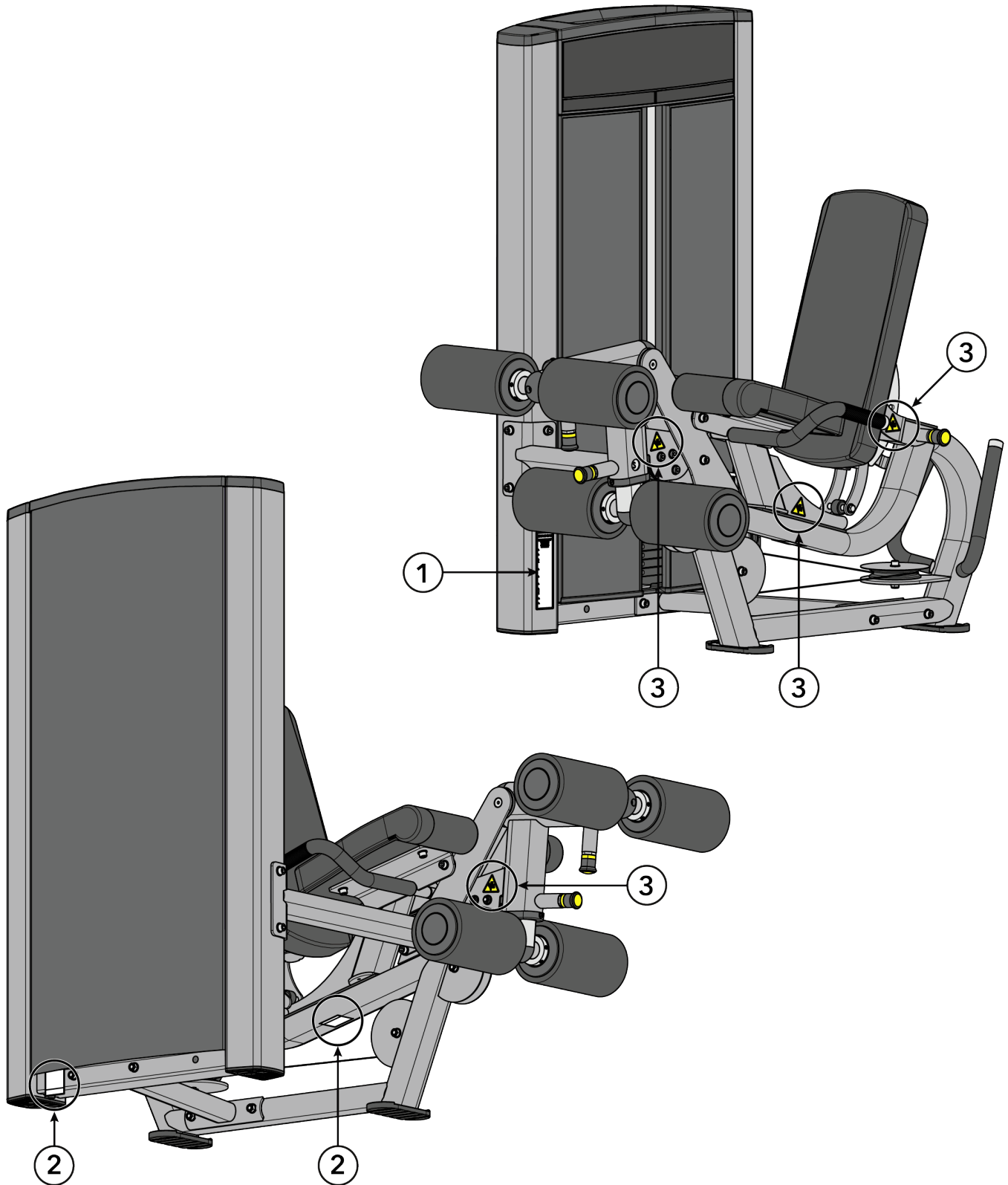

Item	Description	Qty.
1	General Warning	1
2	Serial Number	2
3	Pinch Hazard	4

Multi-Press (OP-MP)

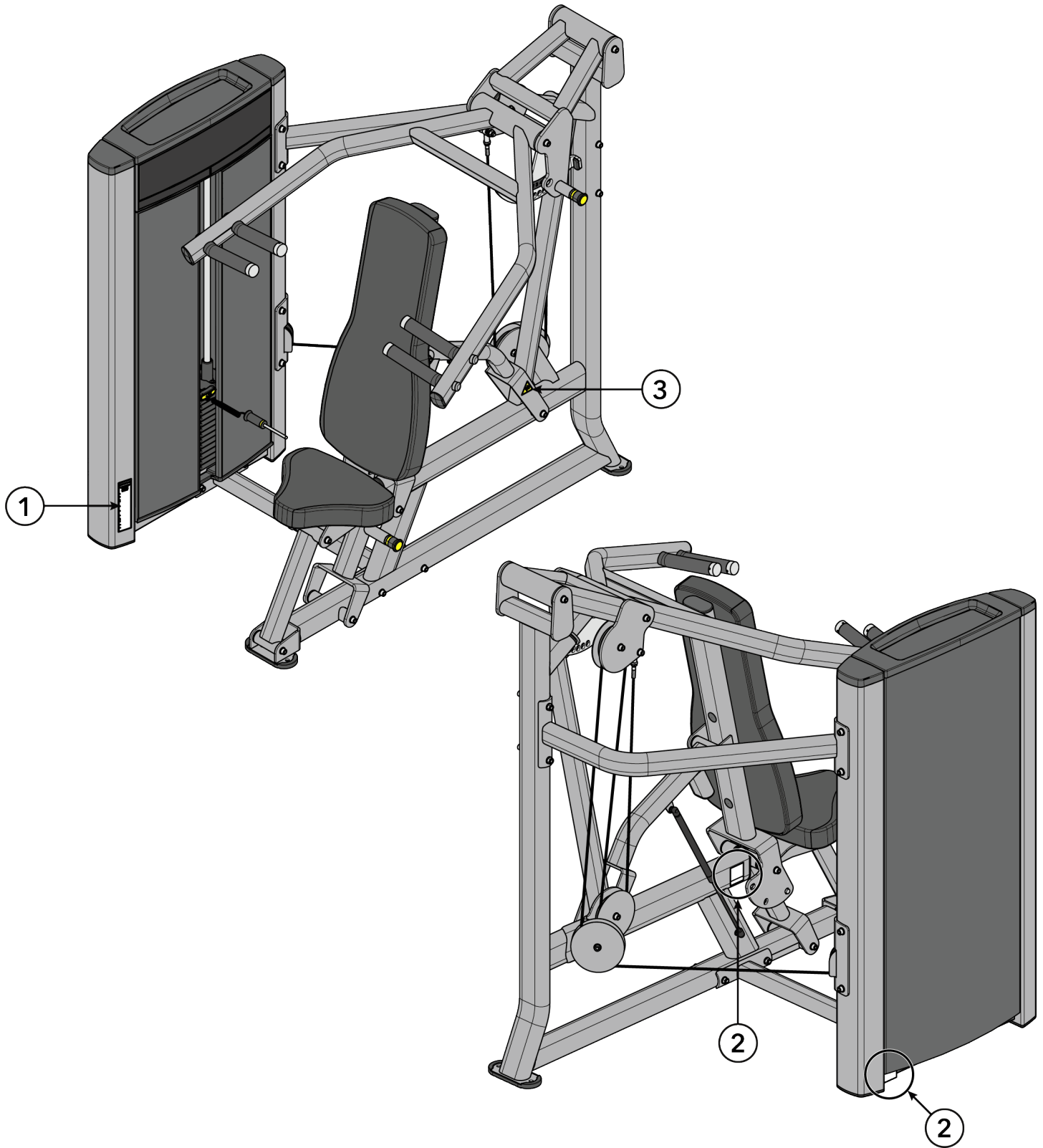

Item	Description	Qty.
1	General Warning	1
2	Serial Number	2
3	Pinch Hazard	1

Pectoral Fly / Rear Deltoid (OP-FLY)

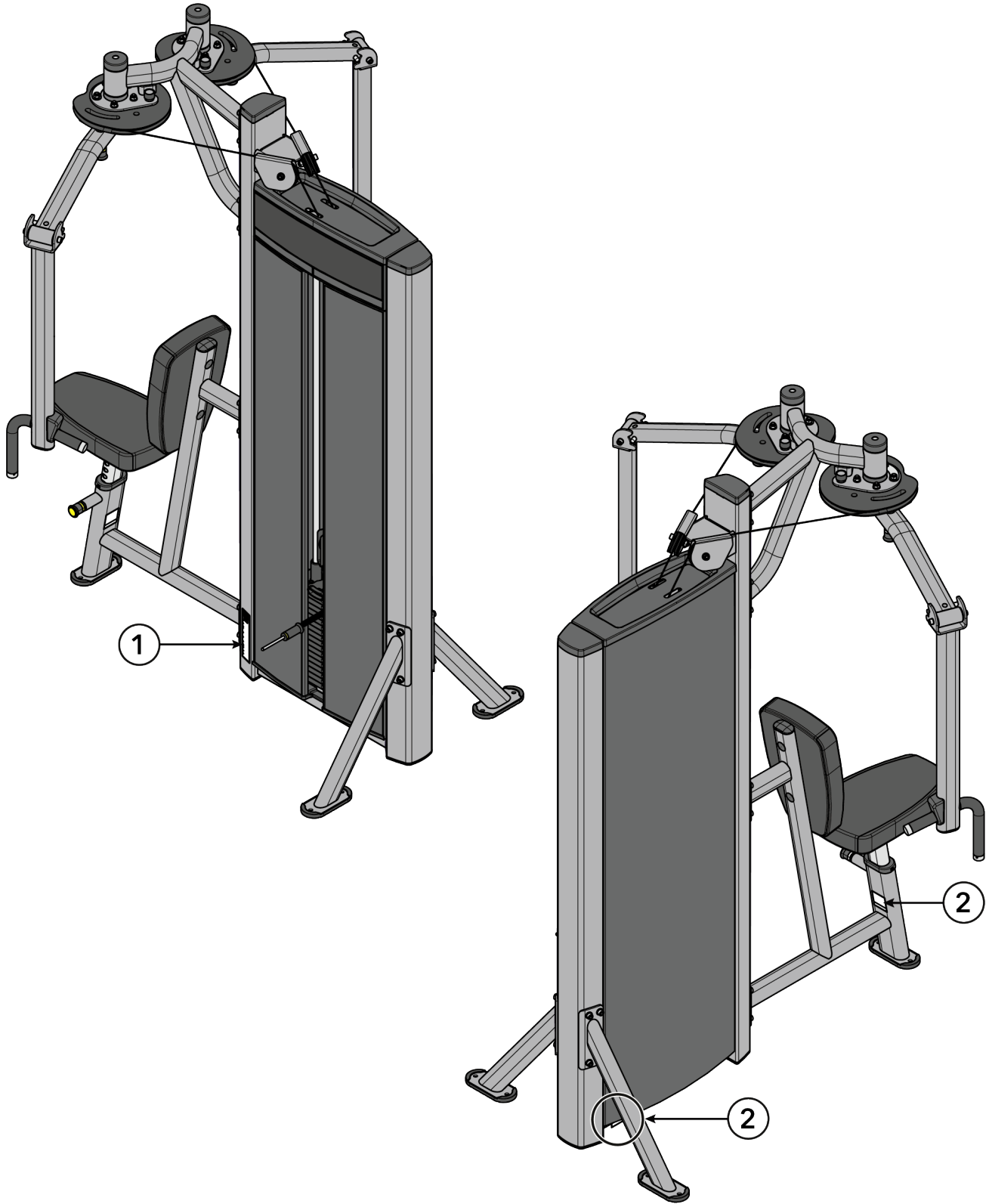

Item	Description	Qty.
1	General Warning	1
2	Serial Number	2

Pulldown / Row (OP-LR)

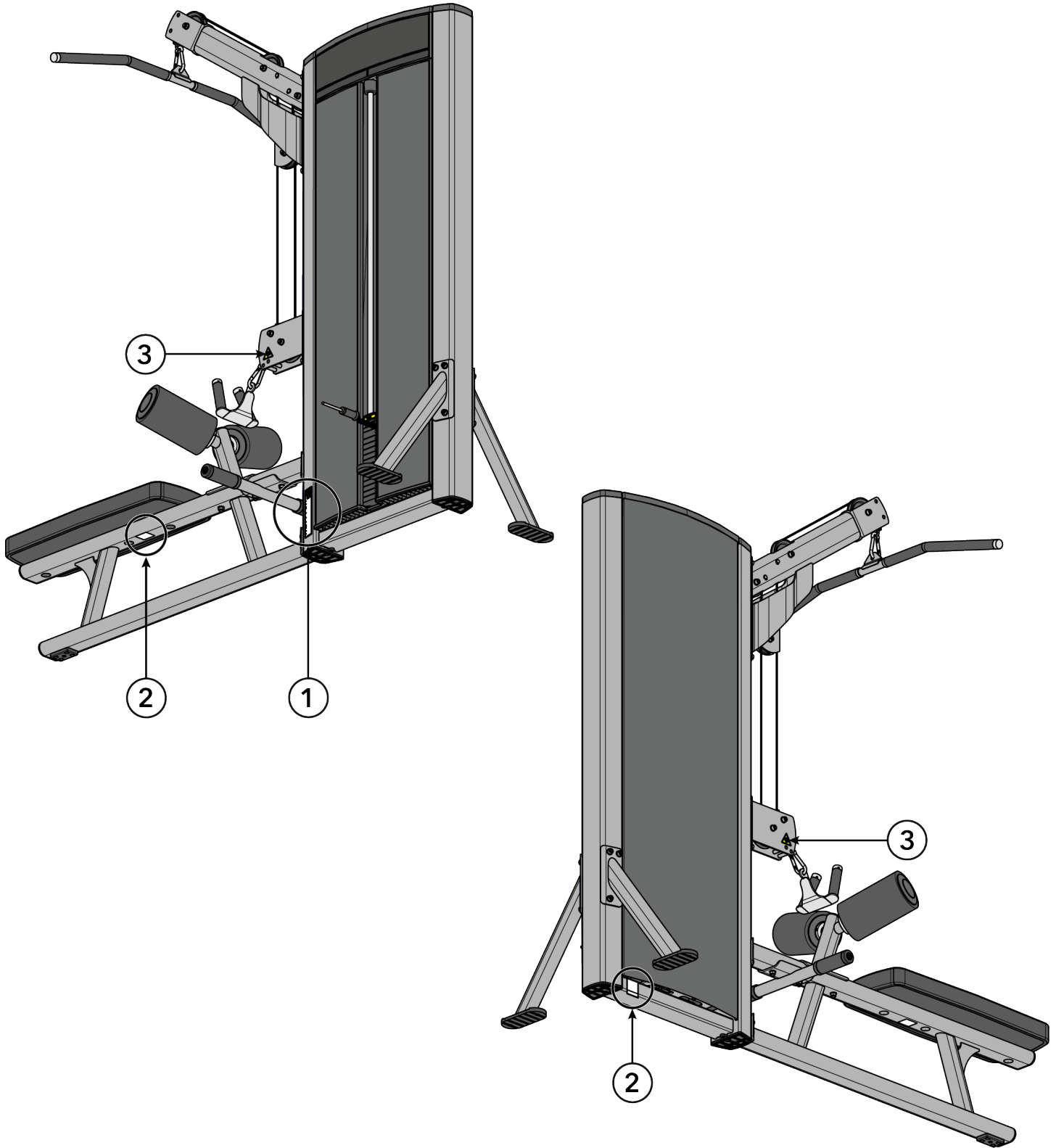

Item	Description	Qty.
1	General Warning	1
2	Serial Number	2
3	Pinch Hazard	2

Seated Leg Curl / Extension (OP-SLCE)

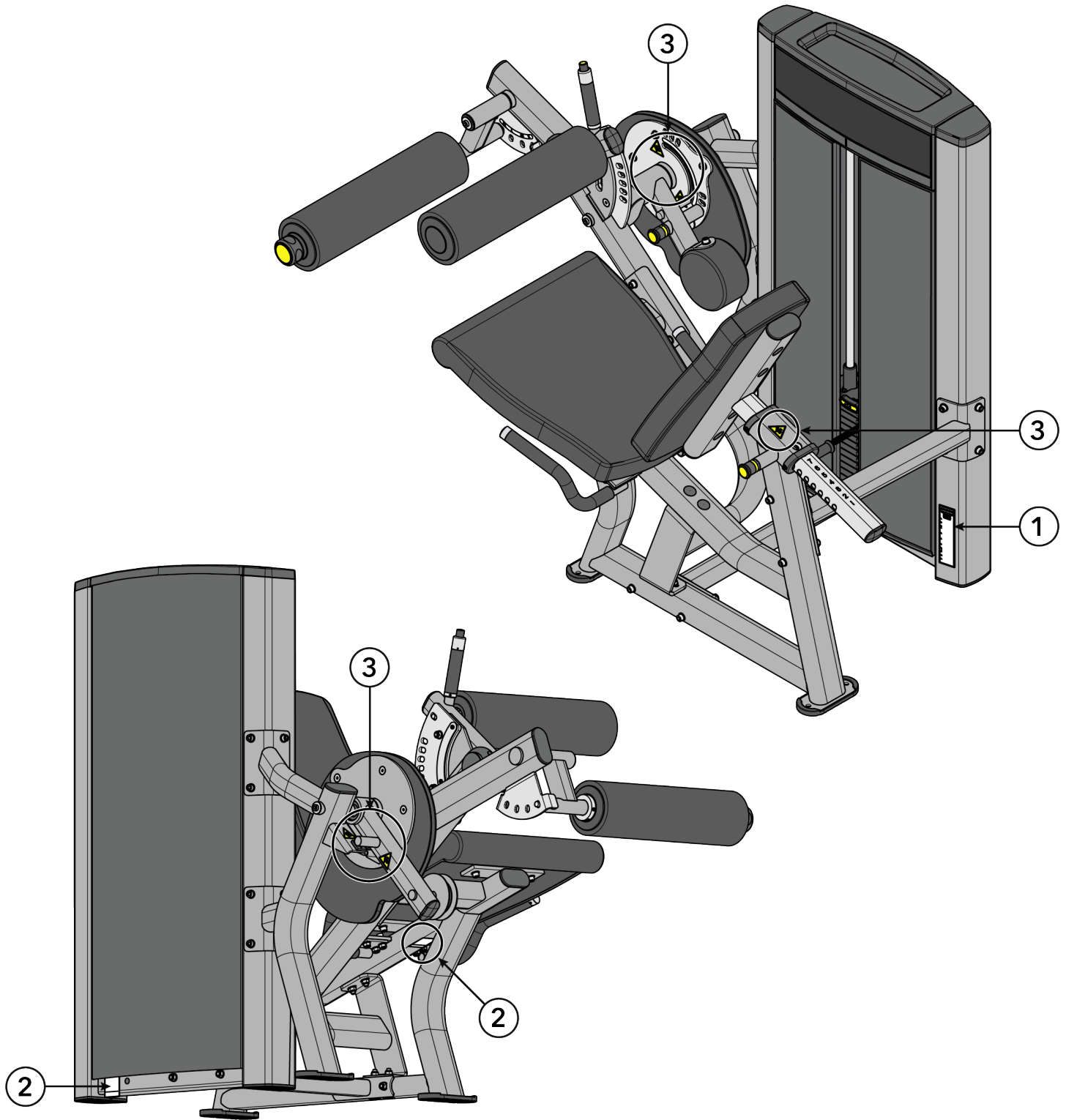

Item	Description	Qty.
1	General Warning	1
2	Serial Number	2
3	Pinch Hazard	5

2. Product Information

Single Stations

Abdominal (OP-AB)

Machine Weight:	384 lbs.	174 kg.
Size (L x W x H):	in. = 50 x 41 x 53	cm = 127 x 104 x 135
Live Area (L x W x H):	in. = 62 x 65 x 77	cm = 157 x 165 x 196
Max User Weight:	300 lbs.	136 kg.
Weight Stack:	142.5 lbs.	71.25 kg.

NOTE: Weight Stack weight includes increment weight (7.5 lbs / 3.75 kg).

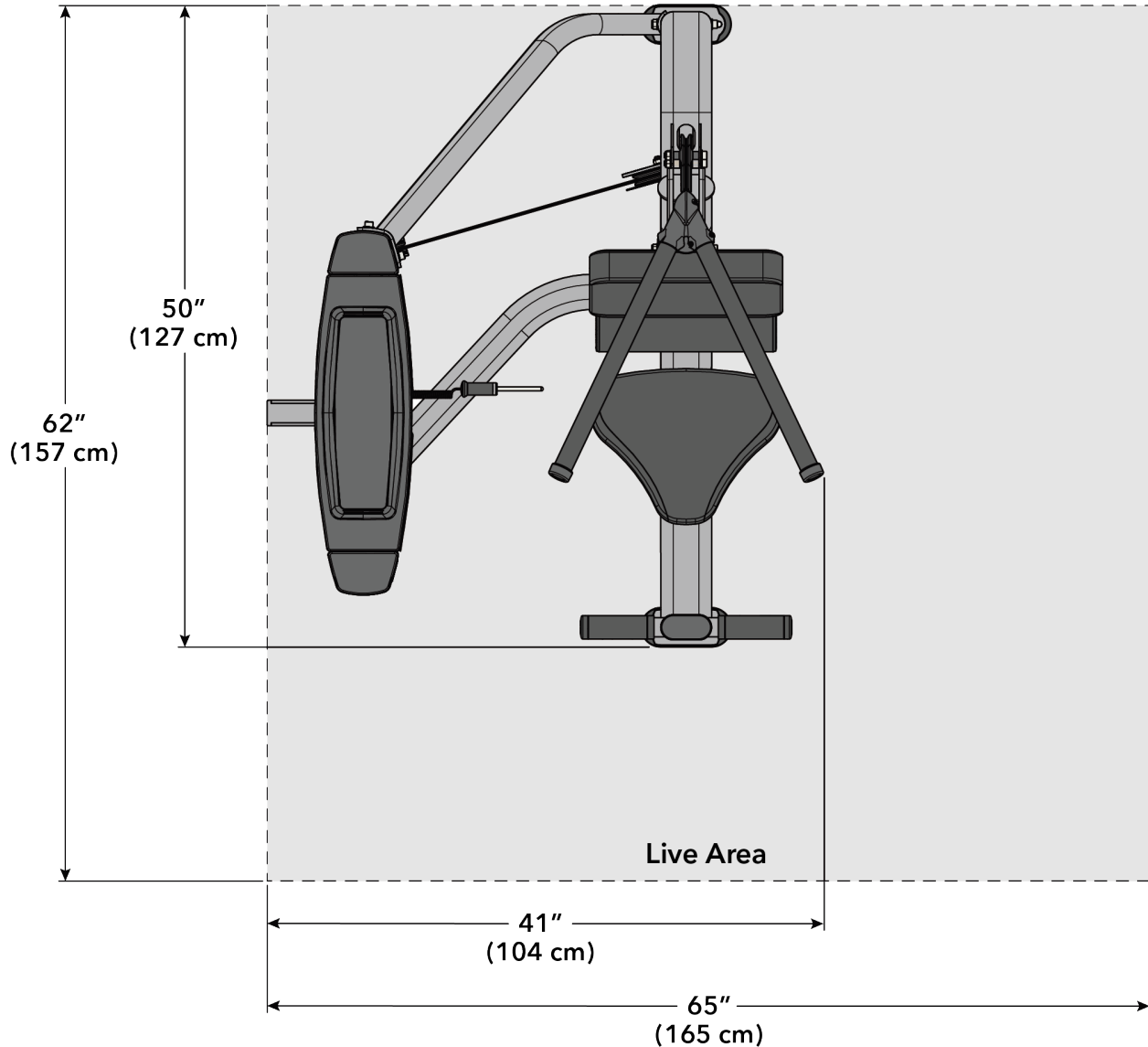

Biceps Curl (OP-BC)

Machine Weight:	403 lbs.	183 kg.
Size (L x W x H):	in. = 55 x 41 x 53	cm = 139 x 104 x 135
Live Area (L x W x H):	in. = 79 x 53 x 77	cm = 200 x 135 x 196
Max User Weight:	300 lbs.	136 kg.
Weight Stack:	172.5 lbs.	86.25 kg.

NOTE: Weight Stack weight includes increment weight (7.5 lbs / 3.75 kg).

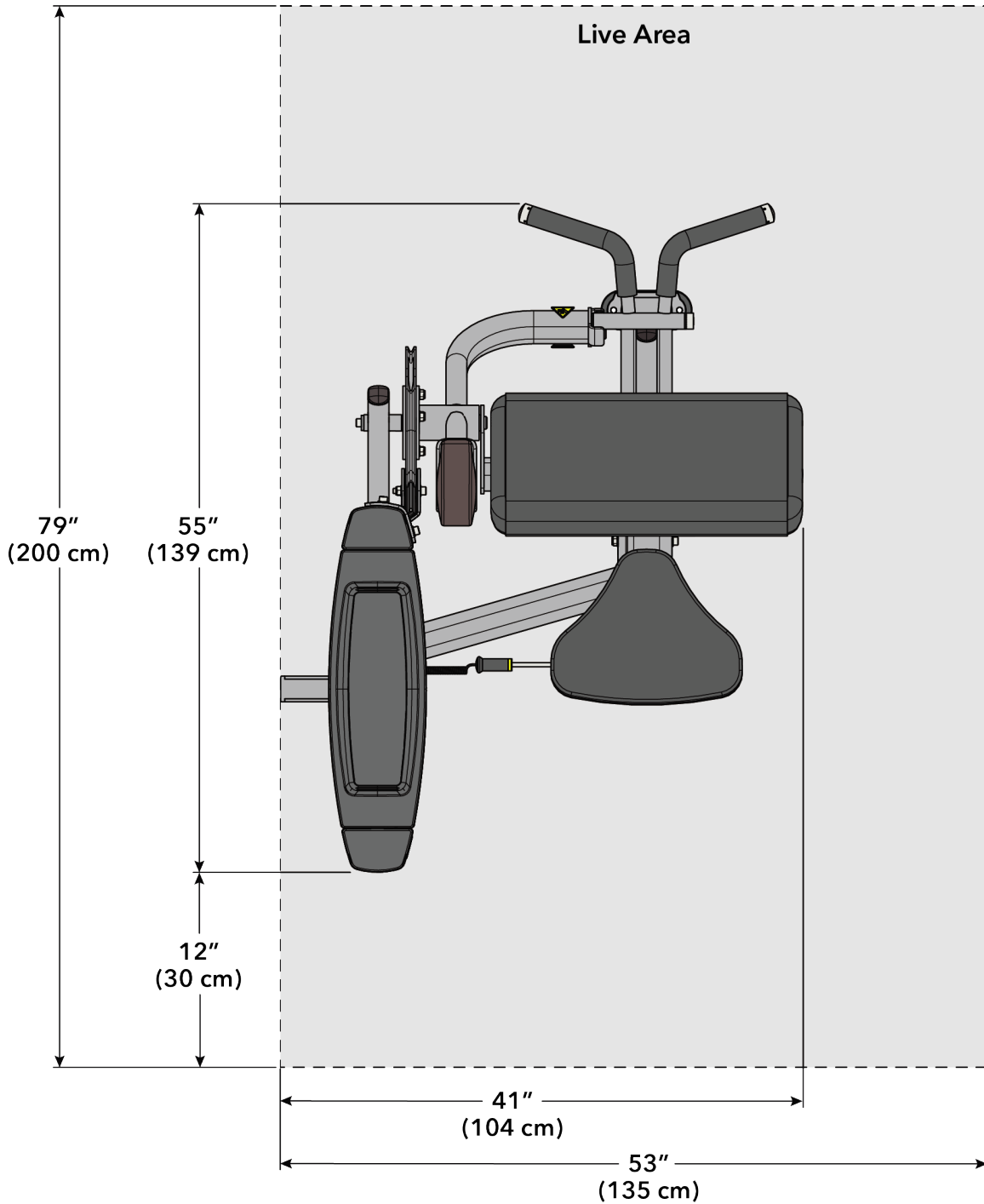

Chest Press (OP-CP)

Machine Weight:	462 lbs.	210 kg.
Size (L x W x H):	in. = 44 x 51 x 53	cm = 112 x 129 x 135
Live Area (L x W x H):	in. = 62 x 63 x 77	cm = 157 x 160 x 196
Max User Weight:	300 lbs.	136 kg.
Weight Stack:	202.5 lbs.	101.25 kg.

NOTE: Weight Stack weight includes increment weight (7.5 lbs / 3.75 kg).

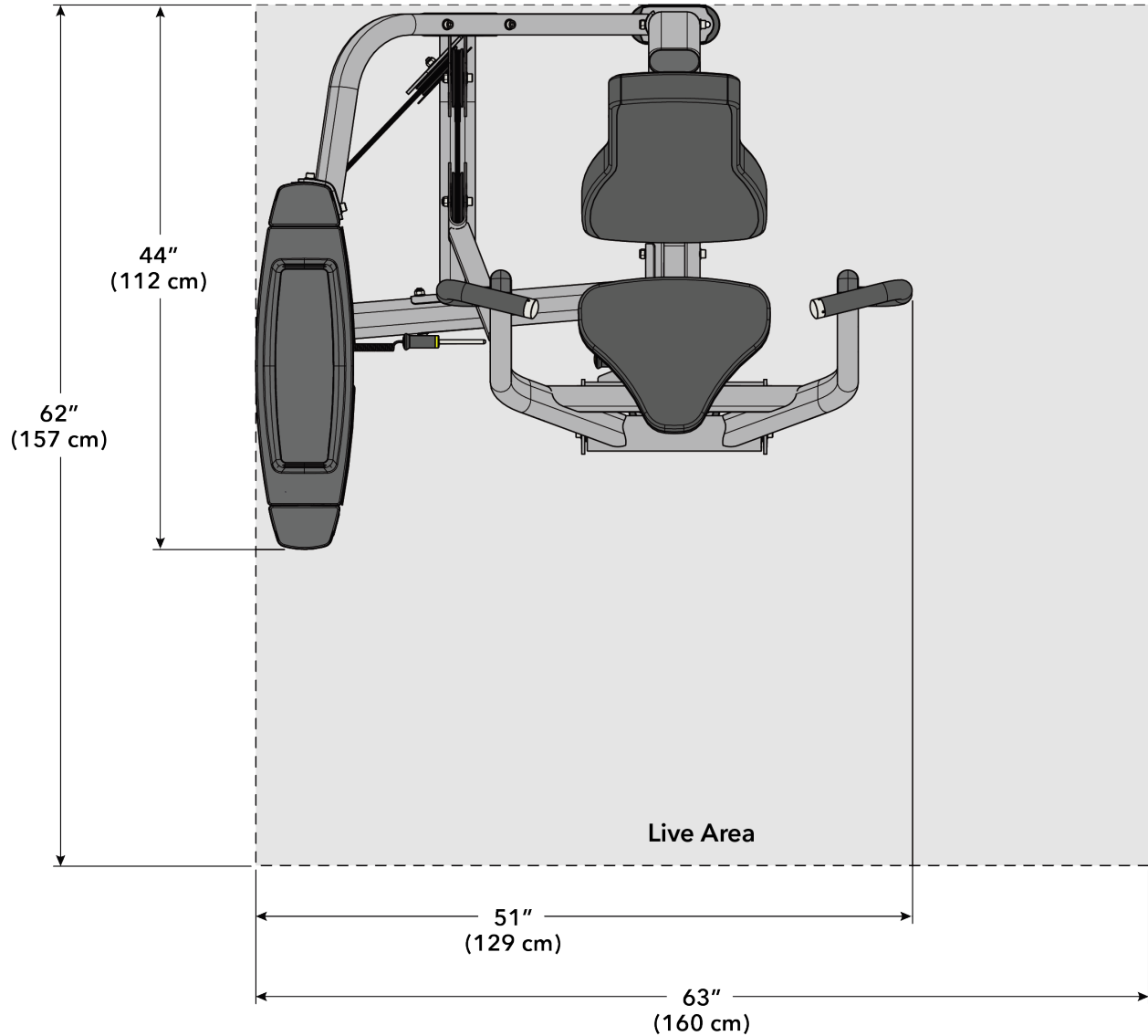

Leg Curl (OP-LC)

Machine Weight:	405 lbs.	184 kg.
Size (L x W x H):	in. = 65 x 43 x 53	cm = 165 x 109 x 135
Live Area (L x W x H):	in. = 101 x 67 x 77	cm = 257 x 170 x 196
Max User Weight:	300 lbs.	136 kg.
Weight Stack:	202.5 lbs.	101.25 kg.

NOTE: Weight Stack weight includes increment weight (7.5 lbs / 3.75 kg).

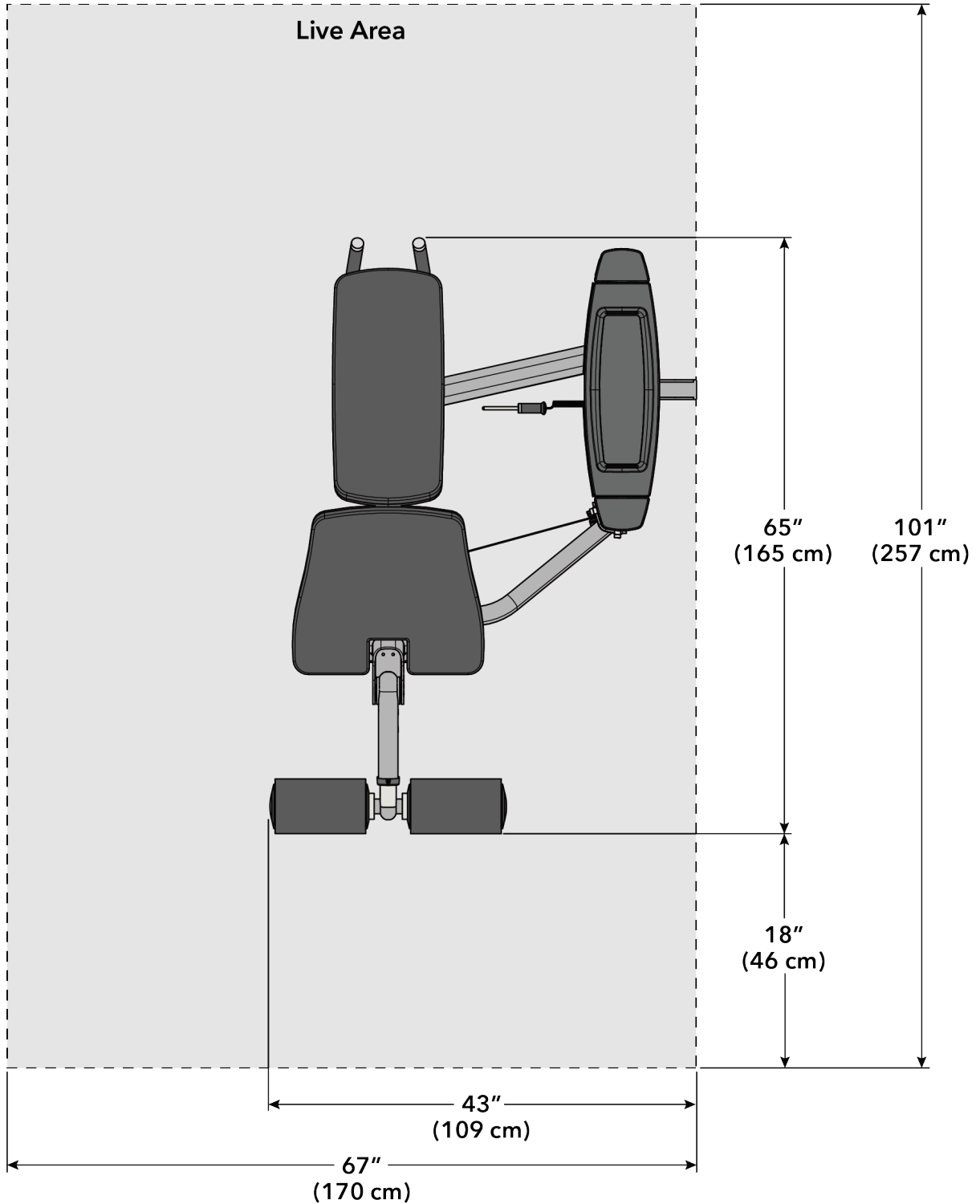

Leg Extension (OP-LE)

Machine Weight:	435 lbs.	197 kg.
Size (L x W x H):	in. = 73 x 40 x 53	cm = 185 x 102 x 135
Live Area (L x W x H):	in. = 103 x 64 x 77	cm = 262 x 163 x 196
Max User Weight:	300 lbs.	136 kg.
Weight Stack:	202.5 lbs.	101.25 kg.

NOTE: Weight Stack weight includes increment weight (7.5 lbs / 3.75 kg).

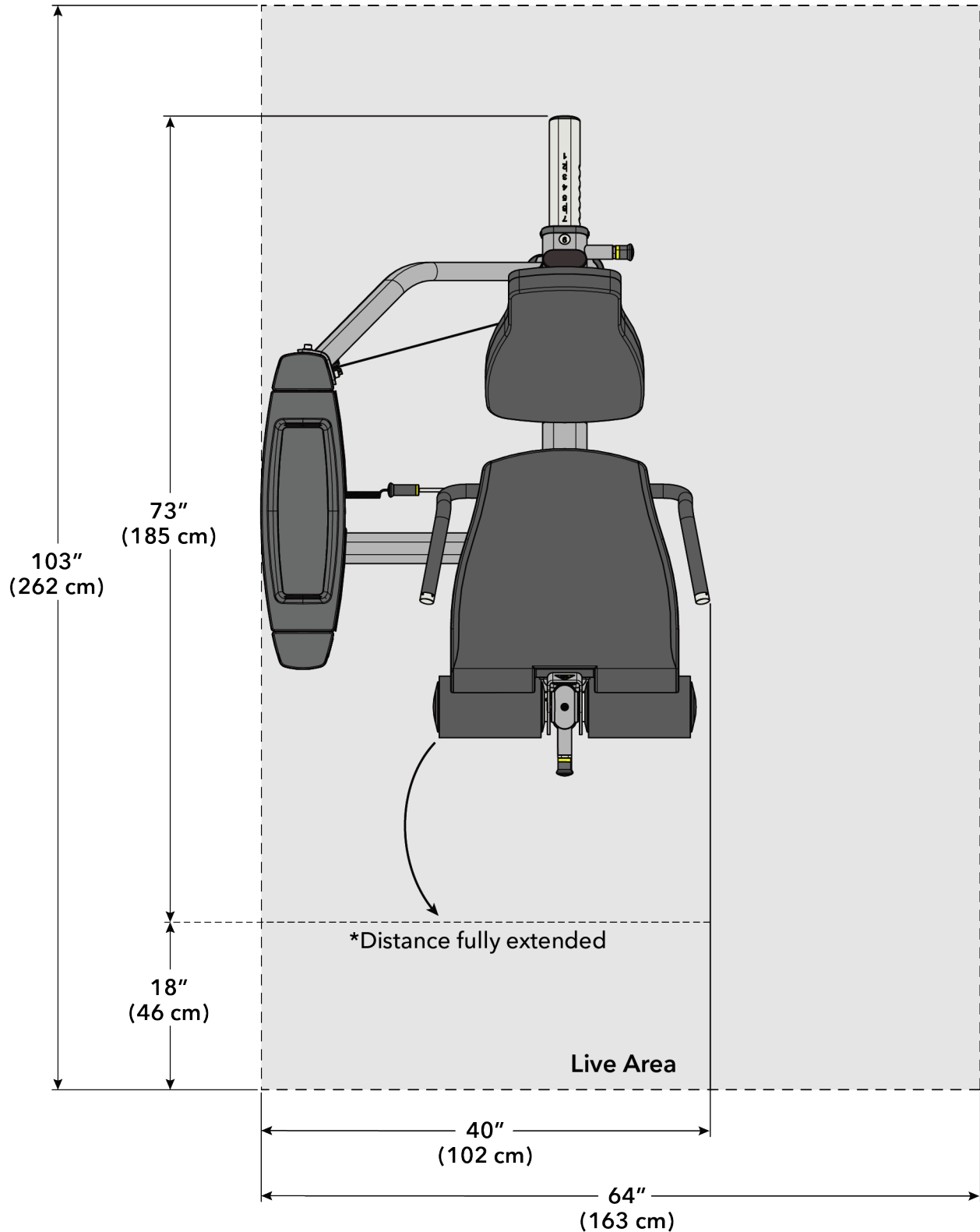

Leg Press (OP-LP)

Machine Weight:	592 lbs.	269 kg.
Size (L x W x H):	in. = 86 x 40 x 53	cm = 218 x 102 x 135
Live Area (L x W x H):	in. = 98 x 64 x 77	cm = 249 x 163 x 196
Max User Weight:	300 lbs.	136 kg.
Weight Stack:	262.5 lbs.	131.25 kg.

NOTE: Weight Stack weight includes increment weight (7.5 lbs / 3.75 kg).

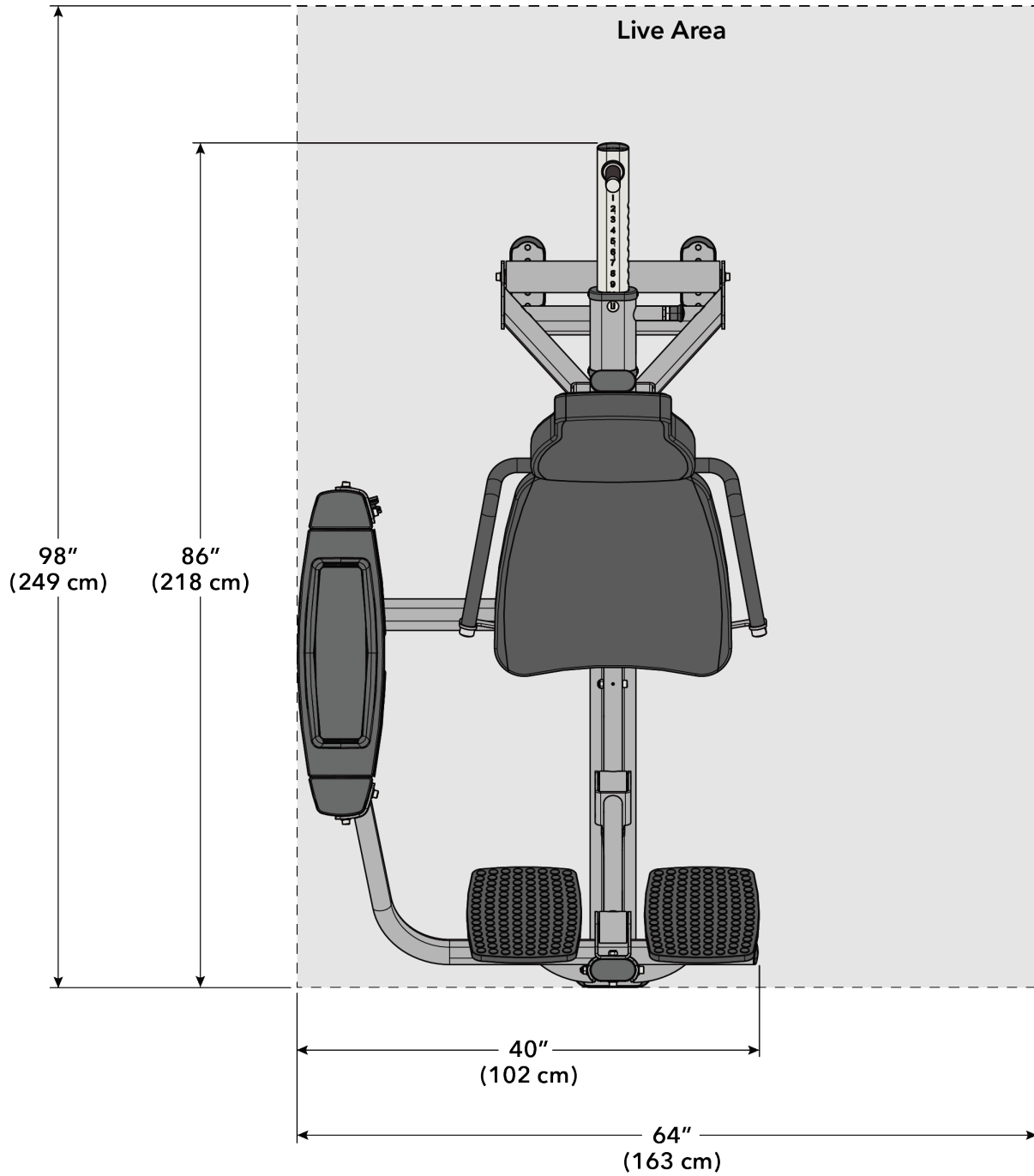

Pulldown (OP-PD)

Machine Weight:	459 lbs.	208 kg.
Size (L x W x H):	in. = 60 x 55 x 73	cm = 152 x 140 x 185
Live Area (L x W x H):	in. = 96 x 67 x 85	cm = 244 x 170 x 216
Max User Weight:	300 lbs.	136 kg.
Weight Stack:	202.5 lbs.	101.25 kg.

NOTE: Weight Stack weight includes increment weight (7.5 lbs / 3.75 kg).

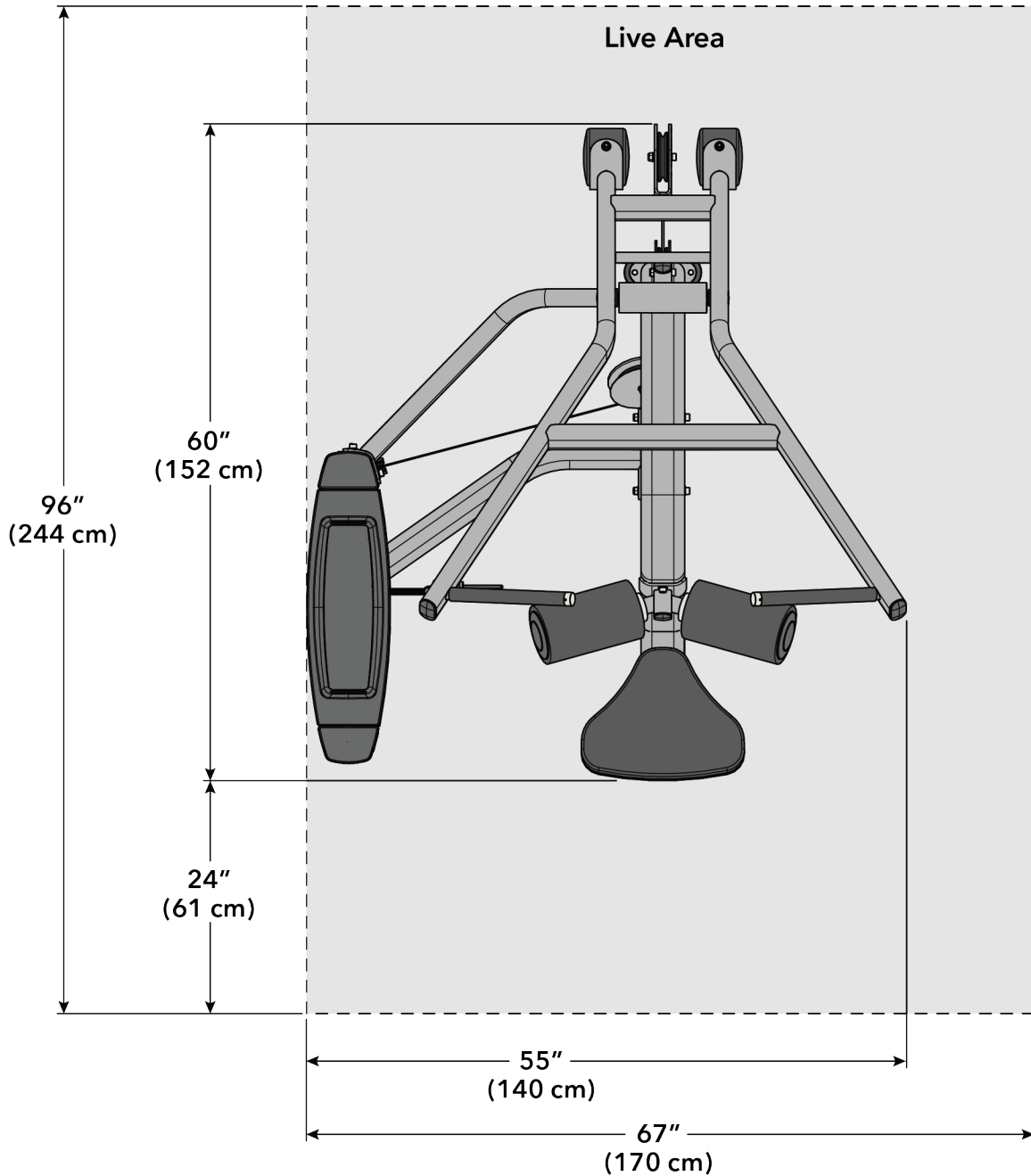

Seated Row (OP-RW)

Machine Weight:	459 lbs.	208 kg.
Size (L x W x H):	in. = 65 x 40 x 53	cm = 165 x 102 x 135
Live Area (L x W):	in. = 89 x 58 x 77	cm = 226 x 147 x 196
Max User Weight:	300 lbs.	136 kg.
Weight Stack:	202.5 lbs.	101.25 kg.

NOTE: Weight Stack weight includes increment weight (7.5 lbs / 3.75 kg).

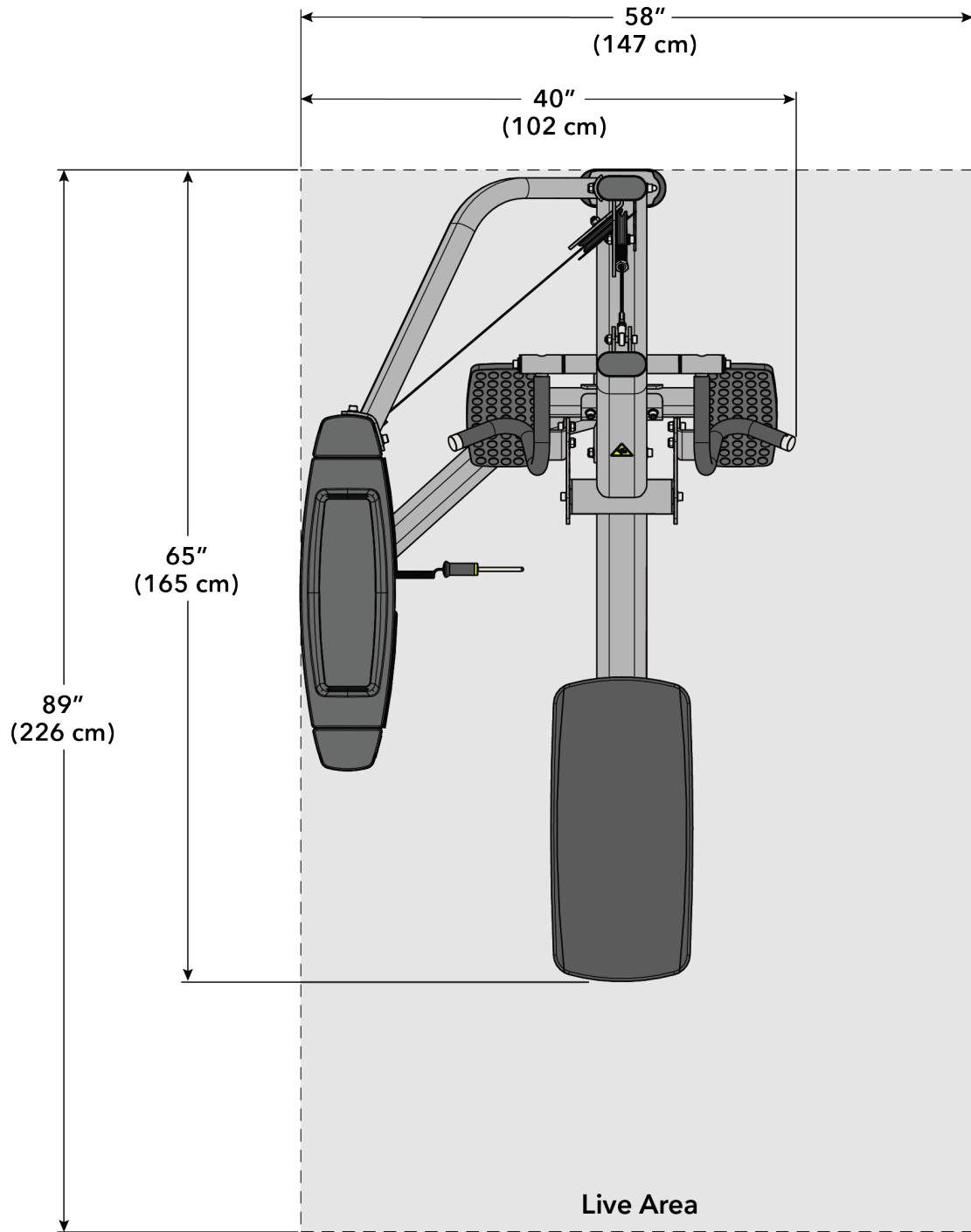

Shoulder Press (OP-SP)

Machine Weight:	484 lbs.	220 kg.
Size (L x W x H):	in. = 61 x 55 x 53	cm = 155 x 140 x 135
Live Area (L x W x H):	in. = 97 x 67 x 77	cm = 246 x 170 x 196
Max User Weight:	300 lbs.	136 kg.
Weight Stack:	172.5 lbs.	86.25 kg.

NOTE: Weight Stack weight includes increment weight (7.5 lbs / 3.75 kg).

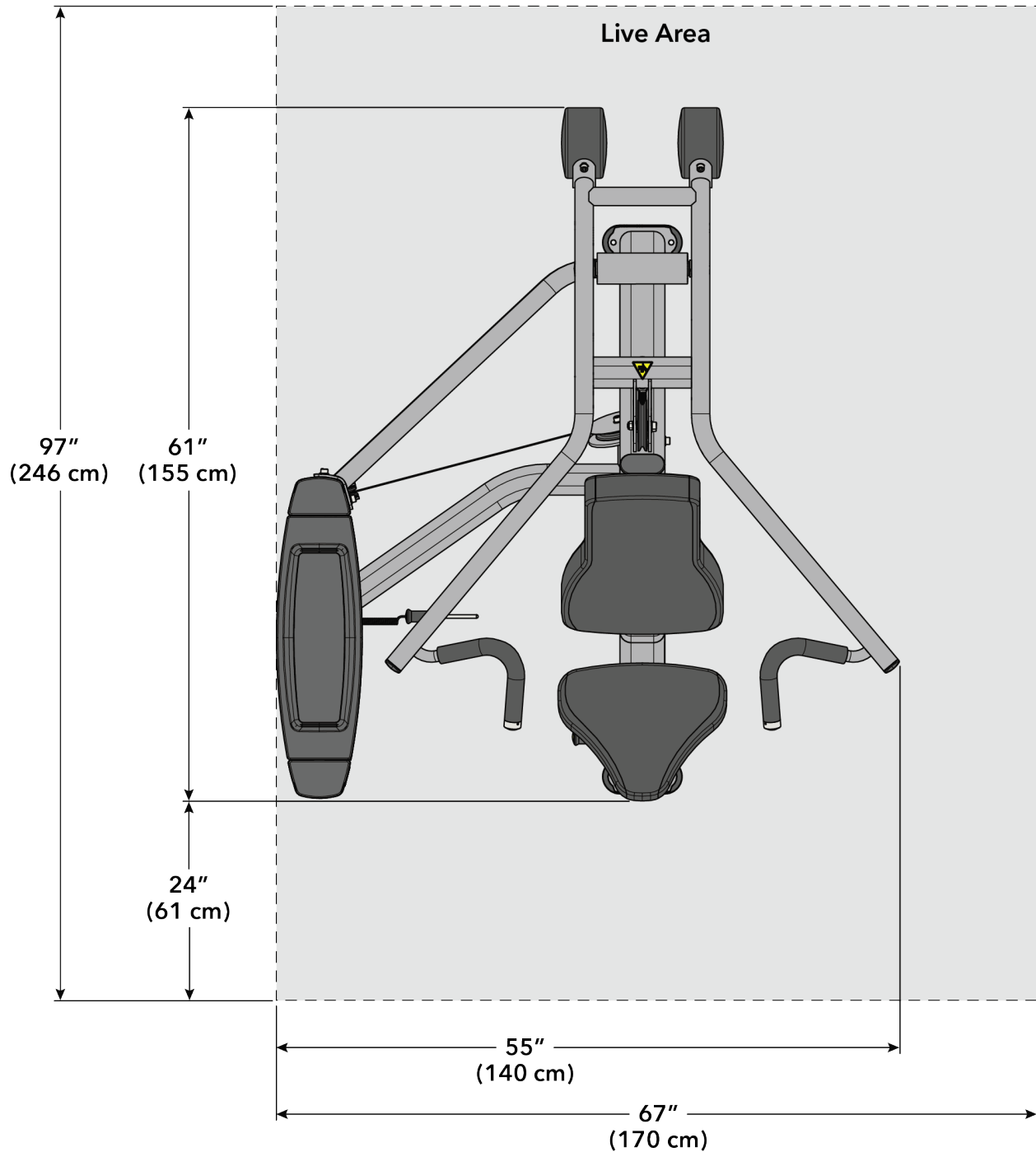

Triceps Extension (OP-TE)

Machine Weight:	379 lbs.	172 kg.
Size (L x W x H):	in. = 57 x 41 x 53	cm = 145 x 104 x 135
Live Area (L x W x H):	in. = 81 x 53 x 77	cm = 206 x 135 x 196
Max User Weight:	300 lbs.	136 kg.
Weight Stack:	142.5 lbs.	71.25 kg.

NOTE: Weight Stack weight includes increment weight (7.5 lbs / 3.75 kg).

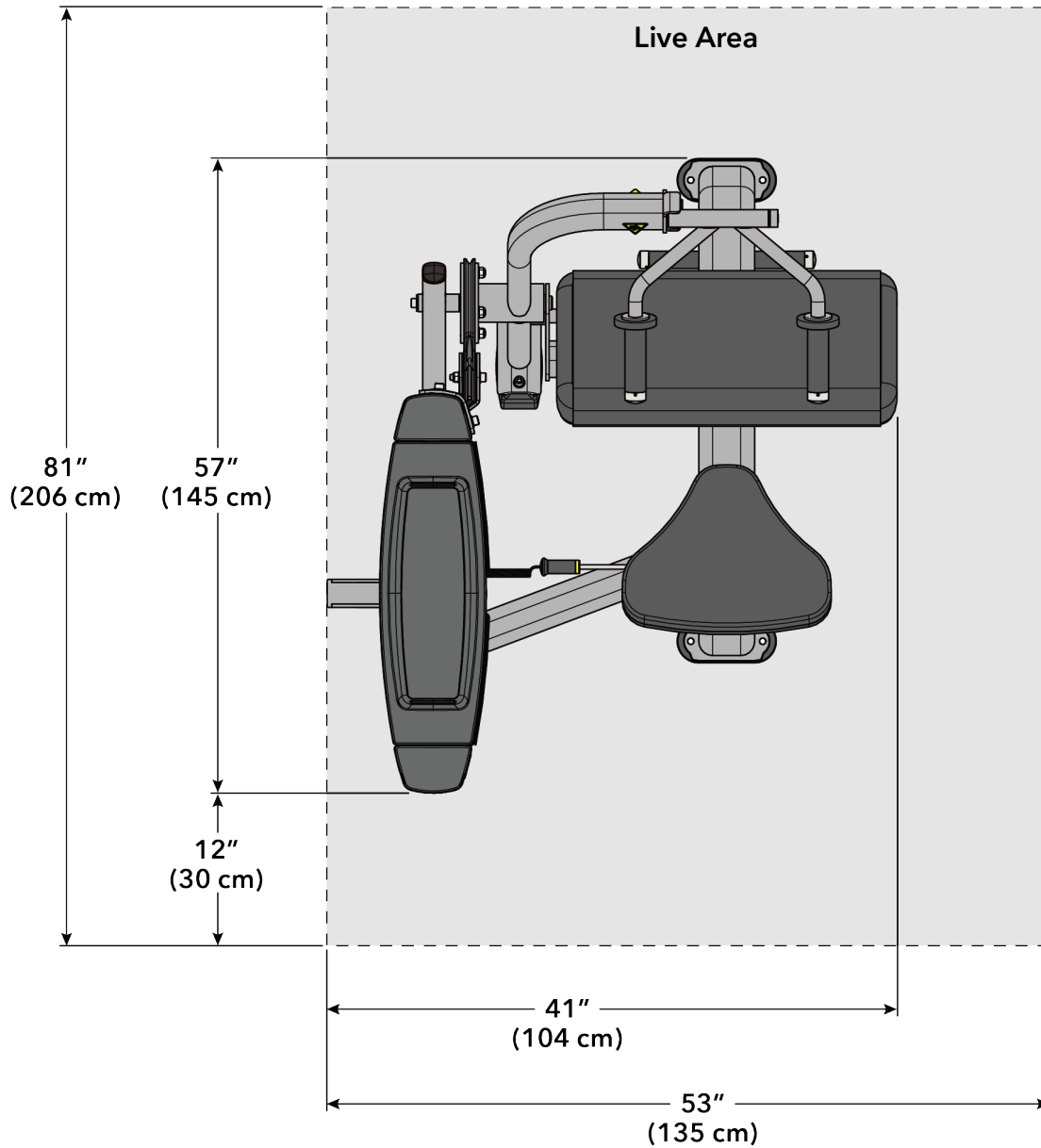

Dual Stations

Abdominal / Back Extension (OP-ABBA)

Machine Weight:	519 lbs.	235 kg.
Size (L x W x H):	in. = 58 x 45 x 53	cm = 147 x 114 x 135
Live Area (L x W x H):	in. = 94 x 69 x 77	cm = 239 x 175 x 196
Max User Weight:	300 lbs.	136 kg.
Weight Stack:	202.5 lbs.	101.25 kg.

NOTE: Weight Stack weight includes increment weight (7.5 lbs / 3.75 kg).

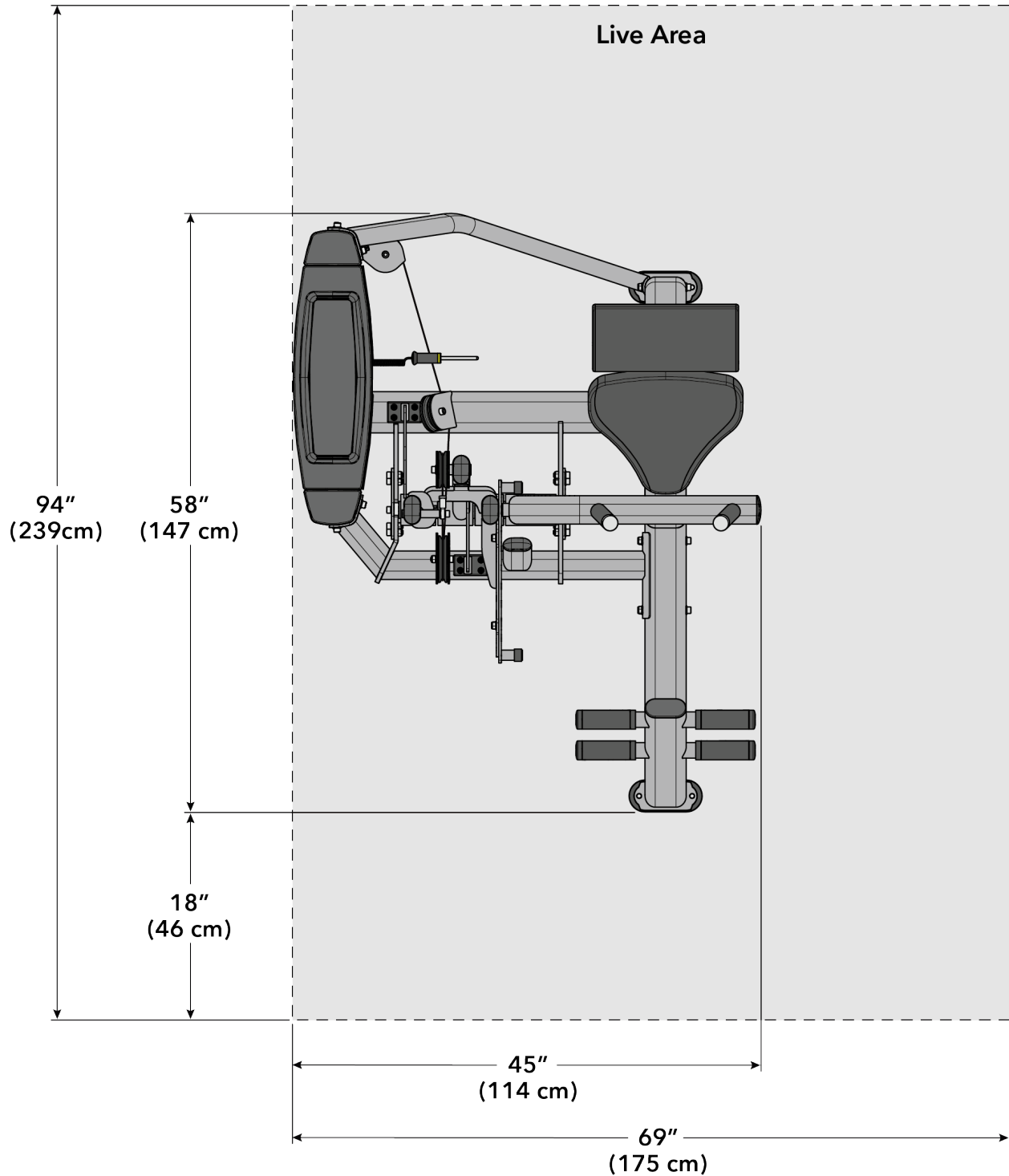

Biceps Curl / Triceps Extension (OP-BT)

Machine Weight:	463 lbs.	210 kg.
Size (L x W x H):	in. = 49 x 43 x 53	cm = 124 x 109 x 135
Live Area (L x W x H):	in. = 73 x 55 x 77	cm = 185 x 140 x 196
Max User Weight:	300 lbs.	136 kg.
Weight Stack:	172.5 lbs.	85.25 kg.

NOTE: Weight Stack weight includes increment weight (7.5 lbs / 3.75 kg).

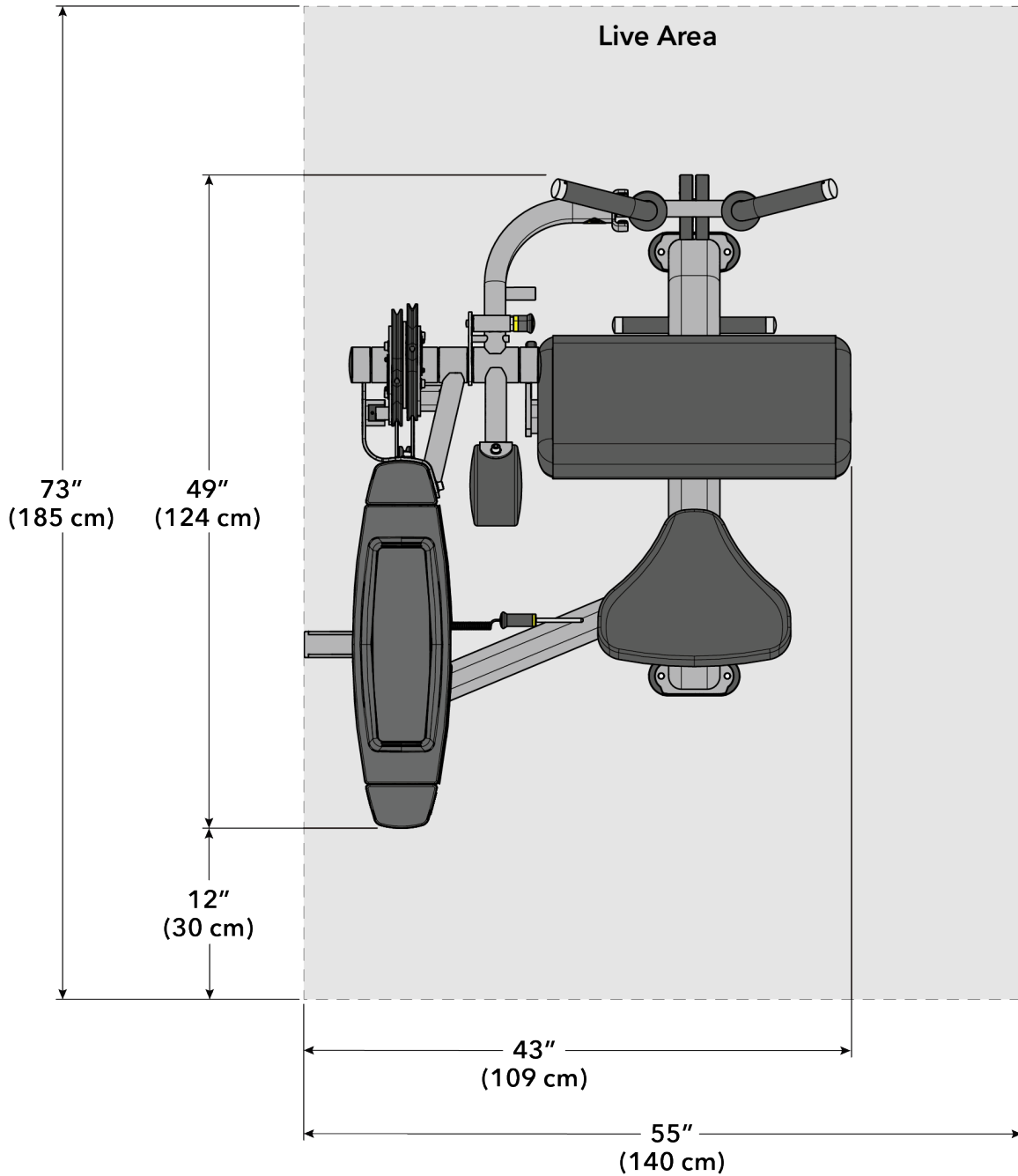

Hip Abductor / Adductor (OP-HAA)

Machine Weight:	432 lbs.	196 kg.
Size (L x W x H):	in. = 68 x 67 x 53	cm = 173 x 170 x 135
Live Area (L x W x H):	in. = 68 x 103 x 77	cm = 173 x 262 x 196
Max User Weight:	300 lbs.	136 kg.
Weight Stack:	142.5 lbs.	71.25 kg.

NOTE: Weight Stack weight includes increment weight (7.5 lbs / 3.75 kg).

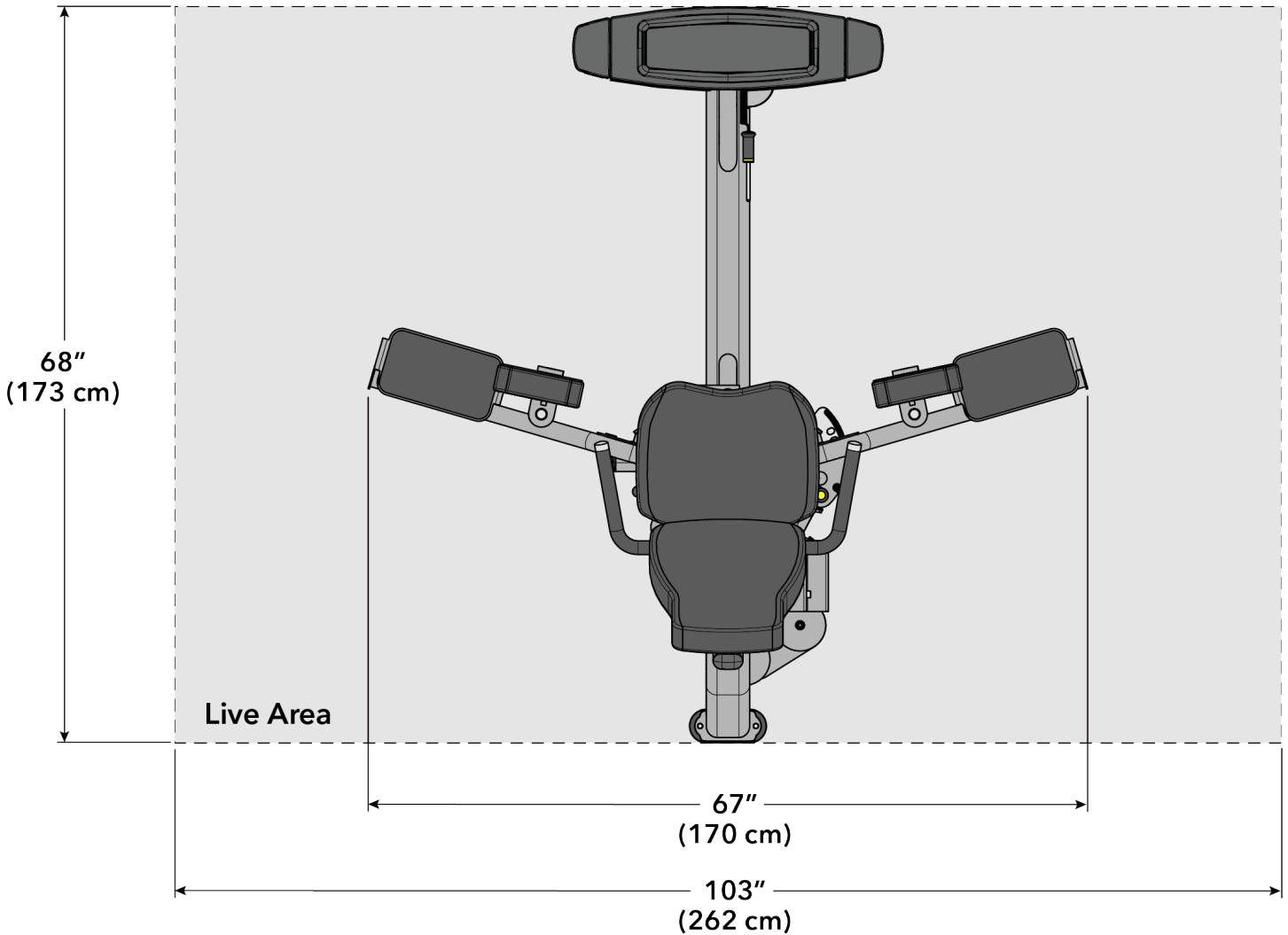

Leg Curl / Extension (OP-LCE)

Machine Weight:	450 lbs.	204 kg.
Size (L x W x H):	in. = 63 x 40 x 53	cm = 160 x 102 x 135
Live Area (L x W x H):	in. = 105 x 64 x 77	cm = 267 x 163 x 196
Max User Weight:	300 lbs.	136 kg.
Weight Stack:	202.5 lbs.	101.25 kg.

NOTE: Weight Stack weight includes increment weight (7.5 lbs / 3.75 kg).

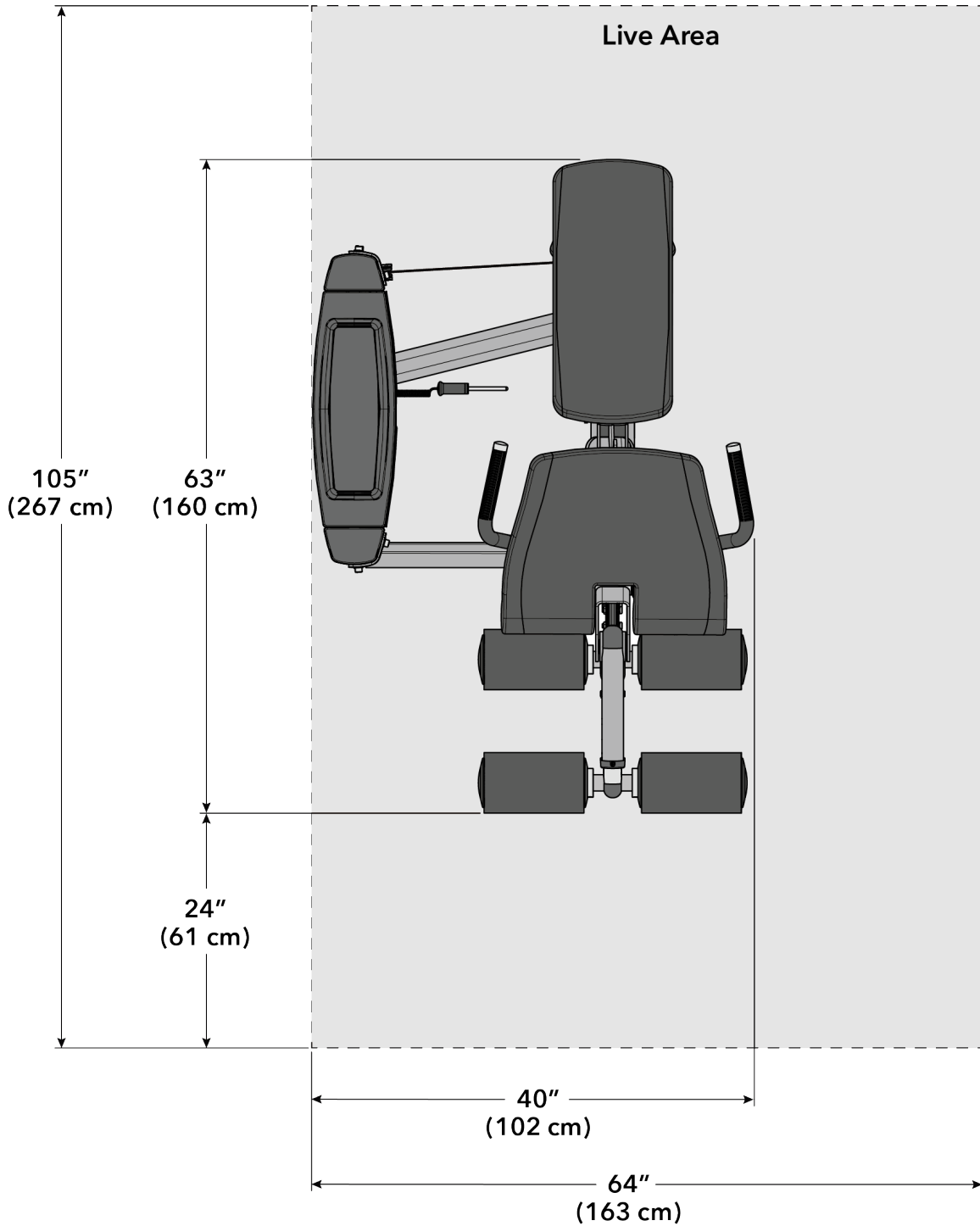

Multi-Press (OP-MP)

Machine Weight:	539 lbs.	245 kg.
Size (L x W x H):	in. = 68 x 54 x 62	cm = 173 x 137 x 157
Live Area (L x W x H):	in. = 92 x 78 x 86	cm = 234 x 198 x 218
Max User Weight:	300 lbs.	136 kg.
Weight Stack:	202.5 lbs.	101.25 kg.

NOTE: Weight Stack weight includes increment weight (7.5 lbs / 3.75 kg).

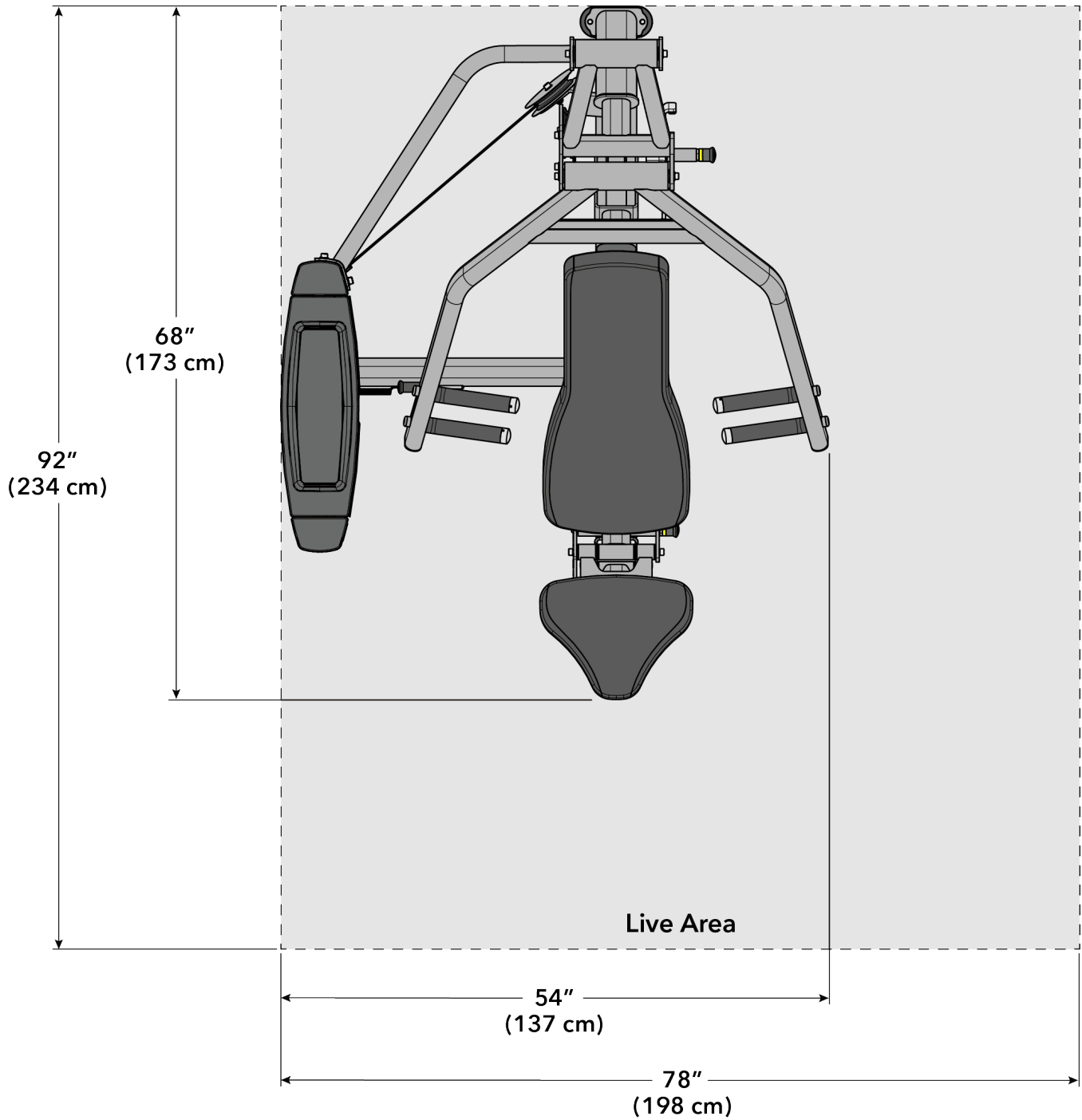

Pectoral Fly / Rear Deltoid (OP-FLY)

Machine Weight:	543 lbs.	246 kg.
Size (L x W x H):	in. = 61 x 75 x 81	cm = 155 x 191 x 206
Live Area (L x W x H):	in. = 97 x 99 x 93	cm = 246 x 251 x 236
Max User Weight:	300 lbs.	136 kg.
Weight Stack:	262.5 lbs.	131.25 kg.

NOTE: Weight Stack weight includes increment weight (7.5 lbs / 3.75 kg).

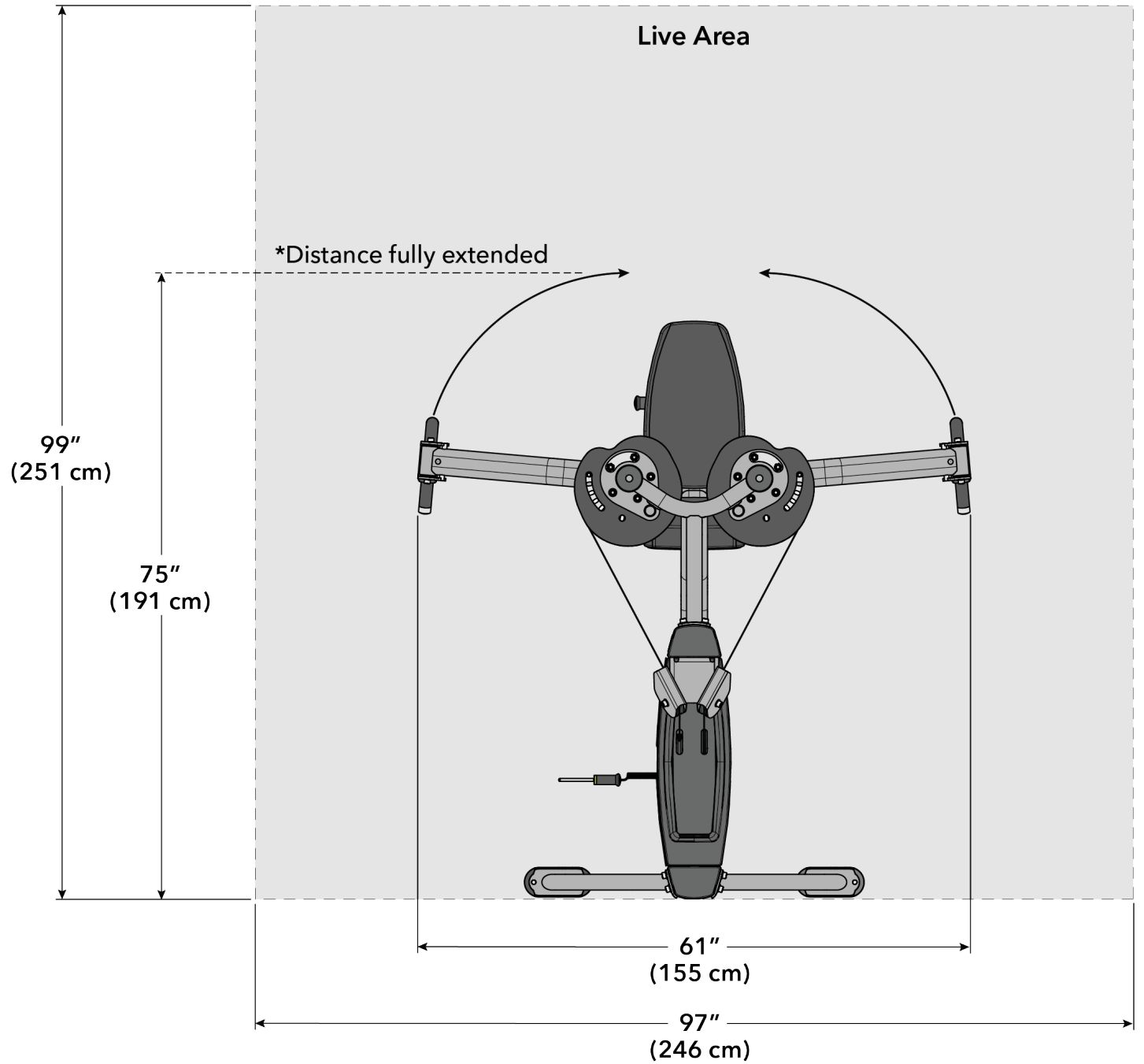

Pulldown / Row (OP-LR)

Machine Weight:	452 lbs.	205 kg.
Size (L x W x H):	in. = 91 x 50 x 85	cm = 231 x 127 x 216
Live Area (L x W x H):	in. = 115 x 86 x 97	cm = 292 x 218 x 246
Max User Weight:	300 lbs.	136 kg.
Weight Stack:	202.5 lbs.	101.25 kg.

NOTE: Weight Stack weight includes increment weight (7.5 lbs / 3.75 kg).

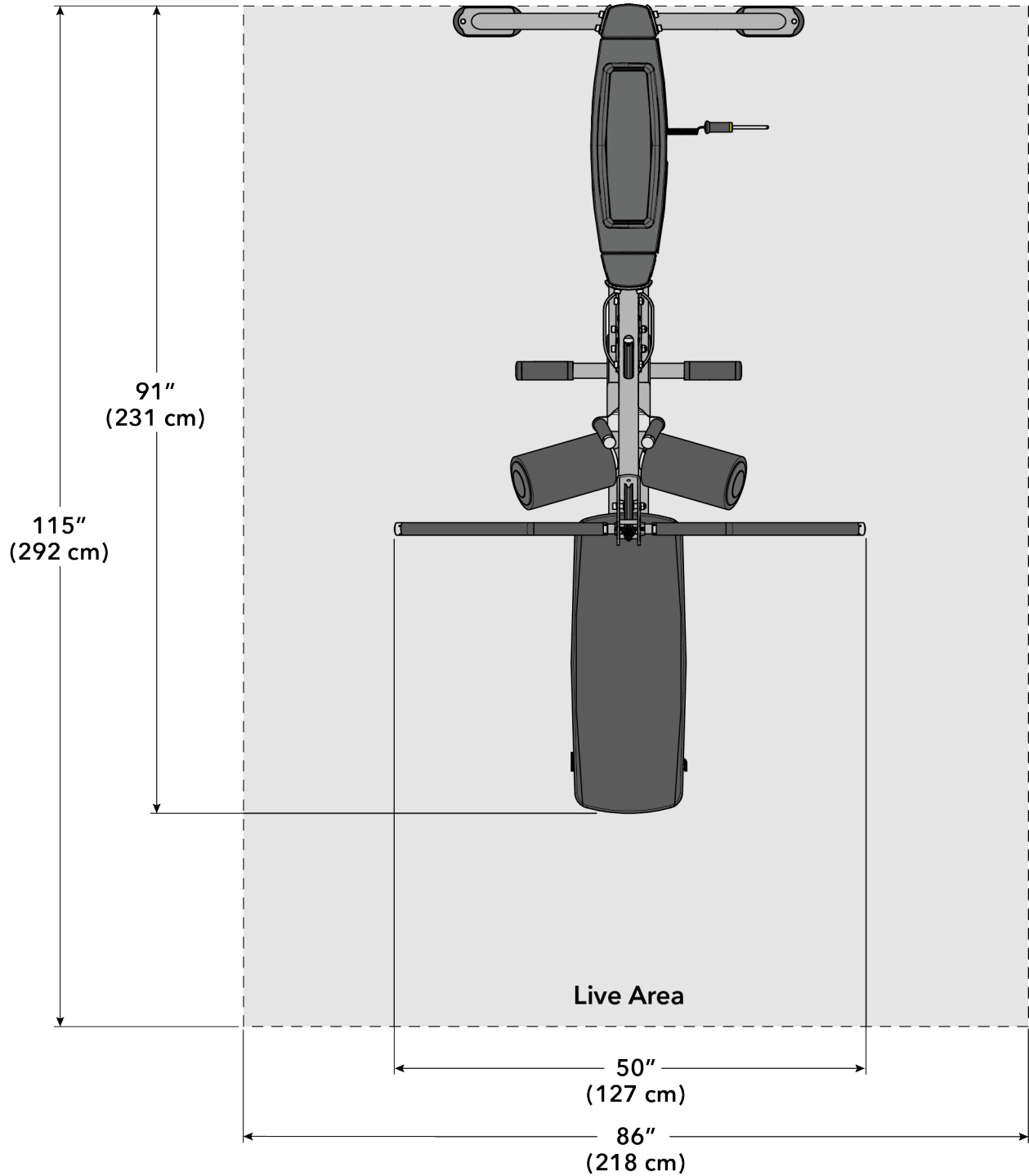

Seated Leg Curl / Extension (OP-SLCE)

Machine Weight:	601 lbs.	273 kg.
Size (L x W x H):	in. = 70 x 46 x 53	cm = 178 x 117 x 135
Live Area (L x W x H):	in. = 100 x 70 x 77	cm = 254 x 178 x 196
Max User Weight:	300 lbs.	136 kg.
Weight Stack:	202.5 lbs.	101.25 kg.

NOTE: Weight Stack weight includes increment weight (7.5 lbs / 3.75 kg).

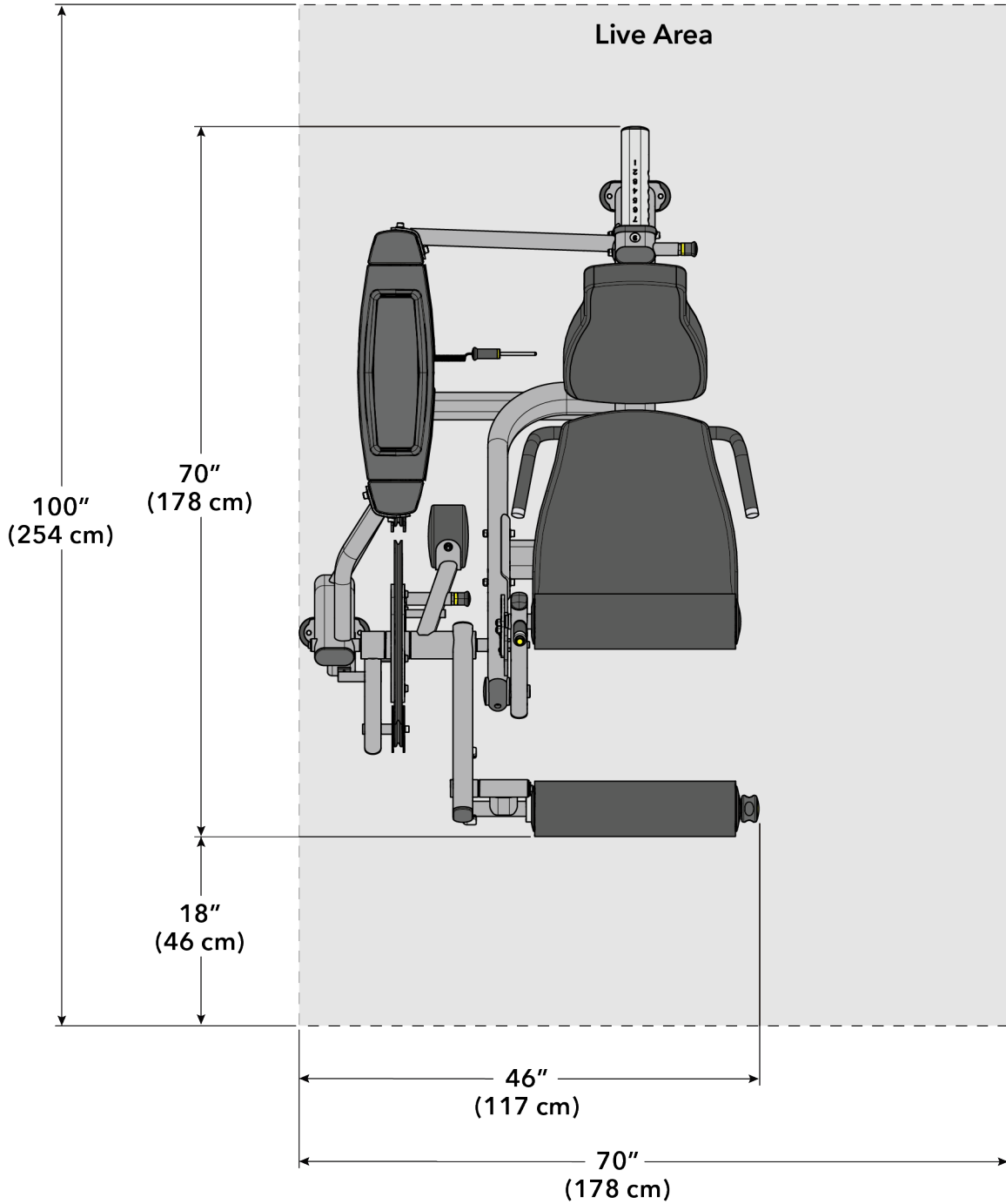

3. Exercise

General Exercise Information

Intended Use

The intended commercial use of this machine is to aid exercise and improve general physical fitness.

Prior to Exercise

Prior to starting a training program, get a complete physical exam to make sure your physician agrees that you are ready. Always warm-up your muscles before a workout. A cardio warm-up followed by stretching is typically recommended.

Start Your Program Conservatively

Choose weights you can easily lift in the first several weeks. Typically, a full range of motion is recommended, but consult a qualified professional if you have questions about whether a full range of motion is appropriate for you due to existing limitations, injury or discomfort. Injuries to health may result from incorrect or excessive training.

A "repetition" (rep) is defined as one complete movement through an exercise, returning to the start position. A "set" is a continuous series of reps, usually between 6-15. During your workout the number of reps you perform in a set depends on your goal. To build muscle and strength, often fewer reps (6 - 8) with heavier weight is recommended in each set. To build endurance, more reps (12-15) with lighter weight is typically recommended.

At the end of your workout, cool down in a similar way to your warm-up.

Single Stations

Abdominal (OP-AB)



Muscles Used:

Abdominals

Setup:

Sit on the seat with your feet placed under the foot supports and lower back pressed against the lumbar pad. Check the weight stack to ensure appropriate resistance. Place the handles over your shoulders. Grasp the handles and place your hands against your chest with your elbows tight to your sides.

Movement:

With a controlled motion, contract torso by shortening the distance between your lower rib cage and your hips. Emphasize the use of your abdominal muscles. Avoid lifting your hands off your chest. Maintaining control, return to the start position and repeat the motion. Concentrate on contracting your abdominal muscles throughout the exercise. Do not return the handles to the rest position until you are finished with the exercise.

Biceps Curl (OP-BC)



Muscles Used:

Biceps

Setup:

Adjust the seat height so the backs of the arms rest fully on the arm pad. Align elbows with the machine's pivot. Check the weight stack to ensure appropriate resistance. Rotate the handles forward. Grip firmly. Position body with chest up and shoulders back. Lean slightly forward to increase stability.

Movement:

With a controlled motion, curl the handles up until the arms are fully flexed. Return to the start position while maintaining resistance on the stack. Repeat the motion, while maintaining proper body positioning.

Chest Press (OP-CP)



Muscles Used: Pectoralis Major, Anterior Deltoid, and Triceps

Setup: Adjust the seat height so the handles are aligned with mid-chest. Check the weight stack to ensure appropriate resistance. Grip the handles. Position elbows slightly below shoulders. Position body with chest up, head up and shoulders against the back pad.

Movement: With a controlled motion, extend the handles out until the arms are fully extended. Return to the start position while maintaining resistance on the stack. Repeat the motion, while maintaining proper body positioning.

Leg Curl (OP-LC)



Muscles Used: Hamstrings

Setup: Lie face down on the pads. Position knees just off the pad. Align knees with the machine's pivot. Position the lower leg pad comfortably above the back of the ankles. Adjust as needed. Check the weight stack to ensure appropriate resistance. Grip the handles located under the chest pad at the head of the machine.

Movement: Keep the hips in contact with the pad. With a controlled motion, curl the legs up until fully flexed. Do not let the hips lose contact with the pad. Return the legs to the start position while maintaining resistance on the stack. Repeat the motion, while maintaining proper body positioning.

NOTE: Excessively lifting the hips off the pad during the exercise can place unwanted stress on the lower back. One method to prevent this is to slightly lift the thighs off the pad and hold while performing the exercise. This action forces the hips downward.

Leg Extension (OP-LE)



Muscles Used:

Quadriceps

Setup:

Adjust the back pad to align the knee joint with the machine pivot (axis of rotation). Adjust the lower leg pad to a comfortable position above the ankle. Check the weight stack to ensure appropriate resistance. Grip the handles located on the sides of the seat. Position body with chest up and with shoulders back and against the back pad.

Movement:

Position thighs so the knees are pointing upwards. With a controlled motion extend the legs to nearly full extension without locking out knees. Return the legs to the start position without letting the resistance rest on the stack. Repeat the motion while maintaining proper body positioning.

Leg Press (OP-LP)



Muscles Used: Quadriceps, Hamstrings, and Gluteus

Setup: Adjust the start position located behind the back pad to the desired range of motion. Position feet on the foot plate, hip width apart, with feet turned out slightly. Check the weight stack to ensure appropriate resistance. Grip the handles on the sides of the seat and position the body with chest up, shoulders and head back against back pad.

NOTE: When positioning the feet on the foot plate, ensure that the feet are placed so that the knees do not move above the toes, as this places excessive stress on the knee joints.

Movement: With a controlled motion, extend the legs until the knees are slightly bent. **DO NOT LOCK THE KNEES.** Return to the start position while maintaining resistance on the stack. Repeat the motion, while maintaining proper body positioning.

Pulldown (OP-PD)



Muscles Used: Latissimus Dorsi and Biceps

Setup: Check the weight stack to ensure appropriate resistance. Stand and grip the bar in the desired position, then pull down and sit with thighs under the pads. Position upper body by leaning slightly forward from the hips and pulling directly over the shoulders.

Movement: With a controlled motion, pull down the handles directly over the shoulders until hands reach shoulder height. Maintain control while the handles return to the start position and repeat the motion while maintaining proper body positioning.

TIP: While performing the exercise, keep the back straight and lower elbows towards lower back to reinforce the correct exercise position.

Seated Row (OP-RW)



Muscles Used: Latissimus Dorsi, Trapezius, Rhomboids, Teres Major and Minor, Posterior Deltoids and Biceps

Setup: Position body so knees are slightly bent, keeping feet firmly on the foot plates. Check the weight stack to ensure appropriate resistance. Grip the handles and position the body with head and chest up and back straight.

Movement: Stabilize the body in position, pressing feet firmly into the foot plates. With a controlled motion, draw back the arms as far as can be controlled. Return the handles to the start position while maintaining resistance. Repeat the motion while maintaining proper body positioning.

TIP: While performing the exercise, keep the back straight and draw the elbows back beyond the body.

Shoulder Press (OP-SP)



Muscles Used: Deltoids and Triceps

Setup: Adjust the seat height so the handles are aligned with, or slightly above shoulder height. Check the weight stack to ensure appropriate resistance. Grip either set of handles. Position body with head up, chest up, and shoulders against the back pad.

NOTE: The neutral grip position is ideal for persons with limited shoulder flexibility or orthopedic limitations.

Movement: With a controlled motion, extend the handles up until the arms are fully extended. Return the handles to the start position while maintaining resistance on the stack. Repeat the motion while maintaining proper body positioning.

TIP: Focus on extending elbows as opposed to pressing arms up.

Triceps Extension (OP-TE)



Muscles Used:

Triceps

Setup:

Adjust the seat height so the backs of the arms rest fully on the arm pad. Align elbows with the machine's pivot. Check the weight stack to ensure appropriate resistance. Rotate the handles backward. Grip firmly. Position feet under the foot supports for stability. Position body with hips in contact with the lower back pad. Lean forward from hips, while keeping the back straight.

Movement:

With a controlled motion, extend the handles out until the arms are fully flexed. Return to the start position while maintaining resistance on the stack. Repeat the motion, while maintaining proper body positioning.

Dual Stations

Abdominal / Back Extension (OP-ABBA)

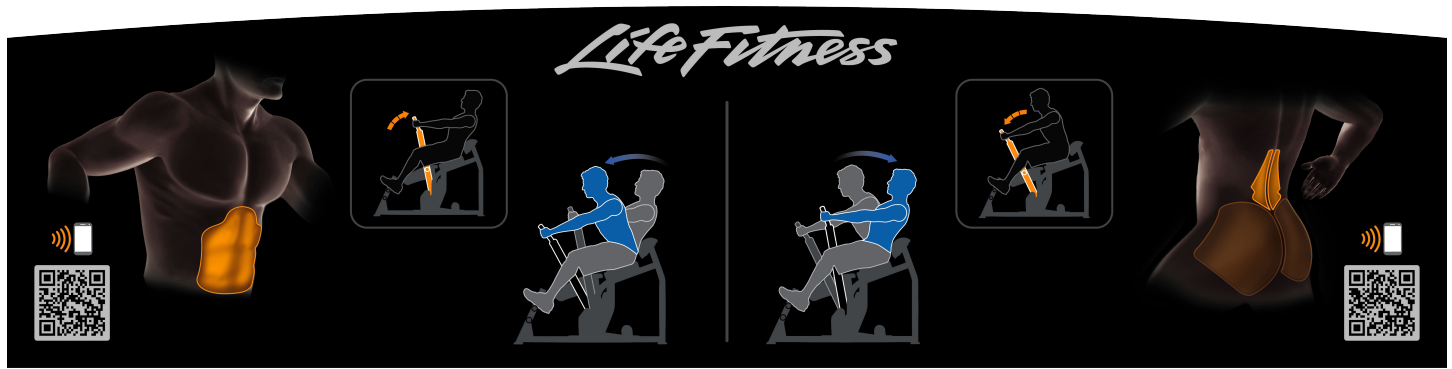

Abdominal

Muscles Used:

Abdominals

Setup:

Sit on the seat with your feet placed on the foot supports and lower back pressed against the lumbar pad. Extend legs to keep back firmly against the lumbar pad while keeping a slight bend at the knees. Check the weight stack to ensure appropriate resistance. Adjust the handles, so that your upper body is leaning back slightly while your arms are extended.

Movement:

With a controlled motion, contract torso by shortening the distance between your lower rib cage and your hips. Emphasize the use of your abdominal muscles. Repeat the motion while maintaining proper body positioning. Concentrate on contracting your abdominal muscles throughout the exercise. Do not return the handles to the rest position until you are finished with the exercise.

Back Extension

Muscles Used:

Erector Spinae, Gluteus

Setup:

Sit on the seat with your feet placed on the foot supports. Check the weight stack to ensure appropriate resistance. Adjust the handles, so that your upper body is rotated forward with the spine bent slightly while your arms are extended.

Movement:

With chest up, grip handles and extend back straightening your spine. Hold the position briefly and return weight with controlled movement to starting position. Repeat the motion while maintaining proper body positioning. Do not return the handles to the rest position until you are finished with the exercise.

Biceps Curl / Triceps Extension (OP-BT)

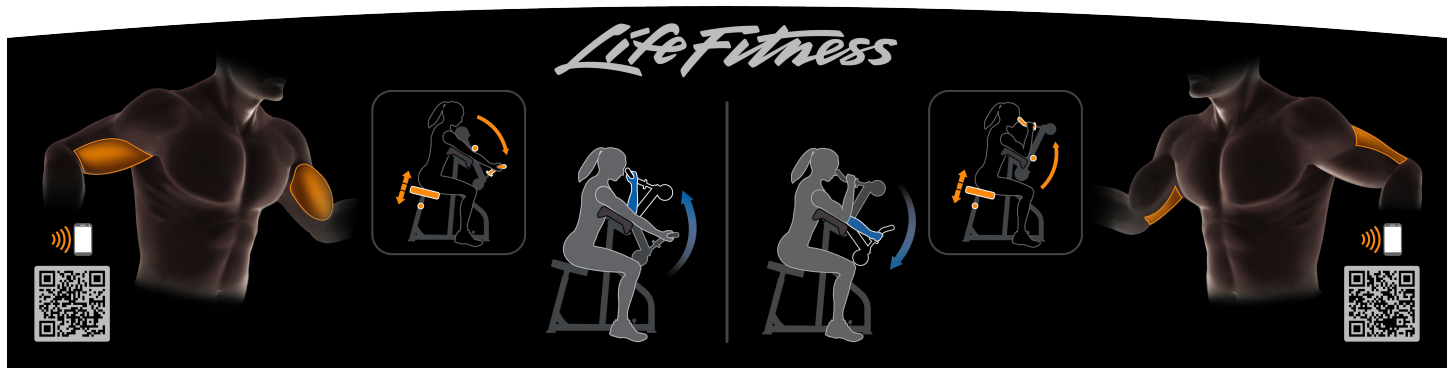

Biceps Curl

Muscles Used: Biceps

Setup: Adjust the handles to the forward position. Adjust the seat height so the backs of the arms rest fully on the arm pad. Align elbows with the machine's pivot. Check the weight stack to ensure appropriate resistance. Position body with chest up and shoulders back. Lean slightly forward to increase stability. Grip handles firmly.

Movement: With a controlled motion, curl the handles up until the arms are fully flexed. Return to the start position while maintaining resistance on the stack. Repeat the motion, while maintaining proper body positioning.

Triceps Extension

Muscles Used: Triceps

Setup: Adjust the handles to the up position. Adjust the seat height so the backs of the arms rest fully on the arm pad. Align elbows with the machine's pivot. Check the weight stack to ensure appropriate resistance. Position feet under the foot supports for stability. Position body with hips in contact with the lower back pad. Lean forward from hips, while keeping the back straight. Grip handles firmly.

Movement: With a controlled motion, extend the handles out until the arms are fully extended. Return to the start position while maintaining resistance on the stack. Repeat the motion, while maintaining proper body positioning.

Hip Abductor / Adductor (OP-HAA)



Hip Abductor

Muscles Used: Hip Abductors

Setup: Rotate the knee pads outward. Sit down. Position feet on foot platform so knees are bent 90 degrees. Adjust the start position to be as narrow as comfort allows.

Movement: Holding the handles, slowly move the pads outward by pushing with the knees. Hold the outward extreme position briefly. Slowly return to the start position.

Hip Adductor

Muscles Used: Hip Adductors

Setup: Rotate the knee pads inward. Sit down. Position feet on foot platform so knees are bent 90 degrees. Adjust the start position to be as wide as comfort allows.

Movement: Hold the handles. Slowly move the pads inward by pushing with the knees. Hold the inward extreme position briefly. Slowly return to the start position. When finished, pull the adjustment knob to release the weight pads to exit the machine.

Leg Curl / Extension (OP-LCE)

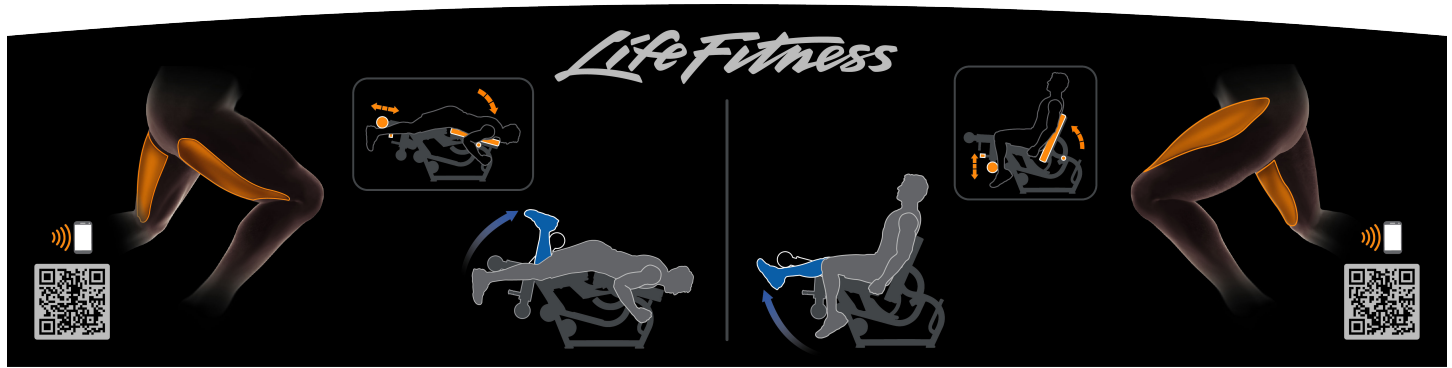

Leg Curl

Muscles Used: Hamstrings

Setup: Adjust the back pad to the horizontal position. Lie face down on the pads. Position knees just off the pad, aligned with the machine's pivot. Position the lower leg pad comfortably above the back of the ankles. Adjust as needed. Grip the handles located under the chest pad at the head of the machine.

Movement: Keep the hips in contact with the pad. With a controlled motion curl the legs up until fully flexed. Do not let the hips lose contact with the pad. Return the legs to the start position while maintaining proper body positioning.

Leg Extension

Muscles Used: Quadriceps

Setup: Adjust the back pad to the vertical position. Sit down and align knee joint with the machine pivot (axis of rotation). Adjust the lower leg pad to a comfortable position above the ankle. Grip the handles located on the sides of the seat. Position body with chest up and with shoulders back and against the back pad.

Movement: With a controlled motion extend the legs to nearly full extension without locking knees. Return legs to the start position without letting the resistance rest on the weight stack. Repeat the motion while maintaining proper body positioning.

Multi-Press (OP-MP)



Chest Press

Muscles Used: Pectoralis Major, Anterior Deltoid, Triceps

Setup: Adjust the press arm to the vertical position labeled #1. Adjust the Seat/Back pad to be in the most flat (slightly angled) position. Position your body on the back pad and select the handles that aligned with the middle of your chest. Grip the handles and position elbows slightly below the shoulders. Position the body with shoulders and head back.

Incline Press

Muscles Used: Pectoralis Major, Anterior Deltoid, Triceps

Setup: Adjust the press arm to the angled position labeled #2-4. Adjust the Seat/Back pad to be in the middle position. Select the handles that aligned with the middle of your chest. Grip the handles and position elbows slightly below the shoulders. Position the body with shoulders and head back.

Shoulder Press

Muscles Used: Deltoids, Triceps

Setup: Adjust the press arm to the horizontal position labeled #5-7. Adjust the Seat/Back pad to be in the vertical position. Select the handles that are slightly forward of your shoulder. Grip the handles and position elbows slightly below the shoulders. Position the body with shoulders and head back.

Movement:

With a controlled motion extend the handles out until the arms are fully extended. Return the handles to the start position without letting the resistance rest on the stack. Repeat the motion while maintaining proper body positioning.

Pectoral Fly / Rear Deltoid (OP-FLY)

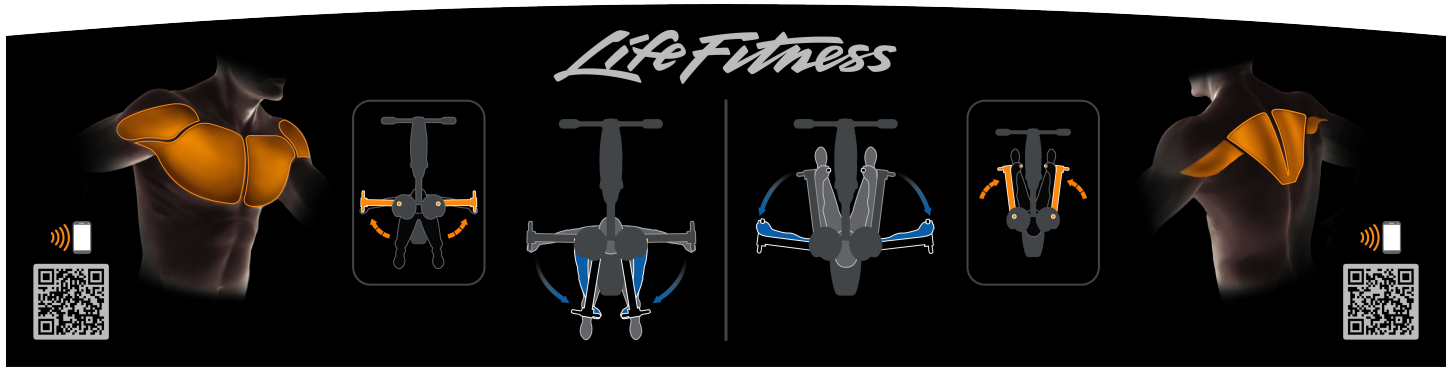

Pectoral Fly

Muscles Used: Pectoralis, Anterior Deltoid

Setup: Sit with back against the vertical pad. The overhead selector pin and handles should be positioned in a wide starting location at the user's sides. Grab the handles keeping hands slightly below shoulder height.

Movement: With a controlled motion and elbows bent, bring hands together. Return the handles to the start position without letting the resistance rest on the weight stack. Repeat the motion while maintaining proper body positioning.

Rear Deltoid

Muscles Used: Posterior Deltoid, Rhomboids, Trapezius, Infraspinatus

Setup: Sit with chest against the vertical pad. The overhead selector pin and handles should be positioned in the narrow starting location in front of the user. Grab the horizontal, or overhand, handles keeping hands slightly below shoulder height.

Movement: With a controlled motion and elbows bent, move hands away from each other. Squeeze shoulder blades together at the end of the movement. Return the handles to the start position without letting the resistance rest on the weight stack. Repeat the motion while maintaining proper body positioning.

Pulldown / Row (OP-LR)



Lat Pulldown

Muscles Used: Latissimus Dorsi, Biceps

Setup: Stand and grip the bar in the desired position. Pull the bar down. Sit with thighs under the thigh pads. Position body to lean back slightly.

TIP: For the ideal grip position, locate the hands as far apart as possible while still allowing the elbows to contact the sides of the body in the down position during the exercise. This ensures a full range of motion.

Movement: With a controlled motion, draw the bar down in front of the chest until it nearly makes contact with the chest. Return the handles to the start position. Repeat the motion while maintaining proper body positioning.

Row

Muscles Used: Latissimus Dorsi, Trapezius, Rhomboids, Posterior Deltoids, Biceps

Setup: Sit down in arms reach of the handles. Grip the handles. Position body with the feet on the foot pegs and head and chest up.

Movement: Stabilize the body in position with feet firmly on foot pegs. With a controlled motion, pull the handle back until elbows are alongside the body. Return the handles to the start position without letting the resistance rest on the weight stack. Repeat the motion while maintaining proper body positioning.

Seated Leg Curl / Extension (OP-SLCE)

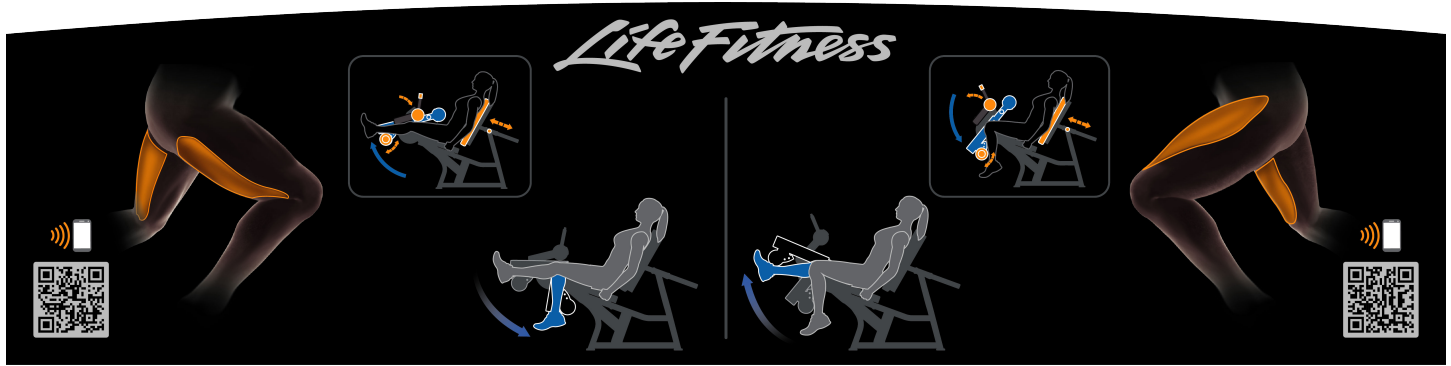

Seated Leg Curl

Muscles Used: Hamstrings

Setup: Adjust the back pad to align the knee joint with the machine pivot (axis of rotation). Adjust the ankle pad so it's positioned just under the ankles. Check the weight stack to ensure appropriate resistance. Grip the handles located on the sides of the seat. Position body with chest up and with shoulders back and against the back pad.

Movement: Curl the pad down and back slowly. Hold the pad at the back position for a moment. Return the legs to the start position without letting the resistance rest on the stack. Repeat the motion while maintaining proper body positioning.

Seated Leg Extension

Muscles Used: Quadriceps

Setup: Adjust the back pad to align the knee joint with the machine pivot (axis of rotation). Adjust the lower leg pad to a comfortable position above and in front the ankle. Check the weight stack to ensure appropriate resistance. Grip the handles located on the sides of the seat. Position body with chest up and with shoulders back and against the back pad.

Movement: With a controlled motion extend the legs to nearly full extension without locking out knees. Return the legs to the start position without letting the resistance rest on the stack. Repeat the motion while maintaining proper body positioning.

4. Maintenance Procedures

Maintenance Schedule

ACTION	DAILY	WEEKLY	MONTHLY	AS NEEDED
CLEAN				
Upholstery	X			
Guide Rods			X	
Shrouds			X	
Hand Grips				X
WAX				
Frames				X
INSPECT				
Paint			X	
Cable	X			
Hardware		X		
Frame		X		
Hand Grips		X		
Shrouds	X			
LUBRICATE				
Guide Rods				X

Clean

- Upholstery with an approved or compatible cleaner.
- Guide rods with a cotton cloth.
- Hand grips with an approved or compatible cleaner.

Wax

- Frames with a standard, non-abrasive, wax finish.

Inspect

- Cables. Look for wear or damage and proper tension. Pay close attention at bends and attachment points.
- Hardware. Check for loosening. Tighten as required.
- Frames. Inspect for wear and damage.
- Handgrips. Check for wear and damage.
- For paint chips. Fill in immediately with manufacturers touch-up paint.
- Jam nut at top of weight stack for tightness.

Lubricate

- Lubricate guide rods with Break-Free® brand lubricant (part number SK50-P0005-0000). Apply the lubricant to a cotton cloth, and then run the cotton cloth up and down the guide rods as needed.

NOTE: Only a few drops of lubricant are required for each guide rod.

Once a Day

- Wipe down upholstery with a mild soap and water or comparable all purpose cleaner.
- Visually inspect cables for wear at and around connections and along the entire length of the cable. Always replace at first sign of wear.

Once a Week

- Visually inspect all hardware for loosening, tampering or wear.
- Check jam nut at top of weight stack for tightness.
- Check condition of hand grips.
- Check cables for stretch and adjust as necessary by loosening the large Jam Nut on top of the weight stack and by screwing in the Threaded Plug until cable is tight and the weight stack pin goes in all holes easily. Securely tighten the large Jam Nut when finished.
- Inspect shrouds for damage and clean as necessary.

Once a Month

- Clean guide rods with Break-Free® brand lubricant (part number SK50-P0005-0000). Clean tops of bearings at stack and inspect for heavy buildup on rods below the head plate. Lift half of stack and do a visual inspection, then clean as necessary.
- Inspect hardware on all machines and tighten any bolts or nuts that may have loosened over the life of the product.

Notes

- Use polishing compound (such as car wax) and remove shoe scuffs from powder coated surfaces as necessary.

Cleaning the Shrouds

- Adherence to regular and proper cleaning procedures is recommended to preserve the appearance.

NOTE: Spray the approved cleaner on a towel, and then wipe down the shrouds to avoid saturation of shroud inlays.

Minimize Scratches

- Wash the shrouds with an approved or compatible cleaner. Do not scrub brushes on the shrouds. Fresh paint splashes, grease and smeared glazing compounds can be removed easily before drying by rubbing lightly with isopropyl alcohol. Afterward, a warm final wash should be made.

Approved and Compatible Cleaners

Two preferred cleaners have been approved by reliability experts: PureGreen 24 and Gym Wipes. Both cleaners will safely and effectively remove dirt, grime and sweat from equipment. PureGreen 24 and the Antibacterial Force formula of Gym Wipes are both disinfectants that are effective against MRSA and H1N1.

PureGreen 24 is available in a spray which is convenient to use. Apply the spray to a microfiber cloth and wipe down the equipment. Use PureGreen 24 on the equipment for at least 2 minutes for general disinfection purposes and at least 10 minutes for fungus and viral control.

Gym Wipes are large, durable pre-moistened wipes to use on the equipment before and after workouts. Use Gym Wipes on the equipment for at least 2 minutes for general disinfection purposes.

Contact Customer Support Services to order these cleaners (1-800-351-3737 or email: customersupport@lifefitness.com).

Mild soap and water or a mild non-abrasive household cleaner can also be used to clean the display and all exterior surfaces. Use a soft microfiber cloth only. Apply the cleaner to the microfiber cloth before cleaning. DO NOT use ammonia or acid based cleaners. DO NOT use abrasive cleaners. DO NOT use paper towels. DO NOT apply cleaners directly to the equipment surfaces.

Removal of Paint, Marking Pens, or Labels

- Butyl cellosolve works well for removal of paints, marking pen inks, lipstick, etc.
- Labels, stickers, etc. may be removed using kerosene. When the solvent will not penetrate sticker material, apply heat (hair dryer) to soften the adhesive and promote removal. GASOLINE SHOULD NOT BE USED.

Important Hazards

- DO NOT use abrasive or highly alkaline cleaners on the shrouds.
- NEVER scrape shrouds with squeegees, razor blades or other sharp instruments.
- DO NOT clean shrouds in hot sun or at elevated temperatures.
- NEVER use benzene, gasoline, acetone or carbon tetrachloride on the shrouds.
- Manufacturer recommends that cables be inspected daily after installation and replaced annually.

5. Warranty

What is Covered

This Life Fitness Family of Brands commercial exercise equipment product is warranted to be free of all defects in material and workmanship.

Who is Covered

The original purchaser or any person receiving the product as a gift from the original purchaser.

Who Pays Transportation and Insurance For Service

If the Product or any covered part must be returned to a service facility for repairs, We, Life Fitness Family of Brands, will pay all transportation and insurance charges for the first year. You are responsible for transportation and insurance charge after the first year.

What We Will Do To Correct Covered Defects

We will ship to you any new or rebuilt replacement part or component, or at our option, replace the Product. Such replacement parts are warranted for the remaining portion of the original warranty period.

What is Not Covered

Any failures or damage caused by unauthorized service, misuse, accident, negligence, improper assembly or installation, debris resulting from any construction activities in the Product's environment, rust or corrosion as a result of the Product's location, alterations or modifications without our written authorization, or by failure on your part to use, operate and maintain the Product as set out in your Operation Manual.

All terms of this warranty are void if this product is moved beyond the continental borders of the United States of America (excluding Alaska, Hawaii and Canada) and are then subject to the terms provided by that country's local authorized Life Fitness Family of Brands representative.

Owner's Manual

It is VERY IMPORTANT THAT YOU READ THIS MANUAL before operating the Product. Remember to perform the periodic maintenance requirements specified in the Manual to assure proper operation and your continued satisfaction.

Exclusive Warranty

THIS LIMITED WARRANTY IS IN LIEU OF ALL OTHER WARRANTIES OF ANY KIND EITHER EXPRESSED OR IMPLIED, INCLUDING BUT NOT LIMITED TO THE IMPLIED WARRANTIES OF MERCHANTABILITY AND FITNESS FOR A PARTICULAR PURPOSE, AND ALL OTHER OBLIGATIONS OR LIABILITIES ON OUR PART. We neither assume nor authorize any person to assure for us any other obligation or liability concerning the sale of this Product. Under no circumstances shall we be liable under this warranty, or otherwise, of any damage to any person or property, including any lost profits or lost savings, for any special, indirect, secondary, incidental or consequential damages of any nature arising out of the use of or inability to use this Product. Some states do not allow the exclusion or limitation of implied warranties or of liability for incidental or consequential damages, so the above limitations or exclusions may not apply to you. Warranty coverages and terms may differ outside the United States. Please contact the Life Fitness office servicing your country (contact information found at the front of this manual) or visit the applicable local Life Fitness website to receive the specific warranty information for your country.

Changes in Warranty Not Authorized

No one is authorized to change, modify or extend the terms of this limited warranty.

Effects of State Laws

This warranty gives you specific legal rights, and you may have other rights which vary from state to state and country by country.

Warranty Coverage

NOTE: There is no warranty coverage for labor on Strength Products.

Item	10 Years	5 Years	1 Year	90 Days
Frame	X			
Pulleys		X		
Weight Plates		X		
Guide Rods		X		
Cables			X	
Grips			X	
Bearings			X	
Upholstery				X
Hardware / Mechanical				X
Items Not Specified				X

6. Cable Handling Guide

Cable Terminations, Tensioning and Wear Guide

Cable Connections with threaded cable ends are required to be installed and maintained following the specifications identified below. Failure to follow these specifications can lead to the dislocation of the threaded cable during use and can cause serious injury. Along with securing the threaded cable end and jam nut, it is important to check the entire unit and ensure that all hardware is securely fastened and not left loose upon completion of cable installation.

⚠ WARNING: Use of non certified "techs" note: Service warranties may be void if a non-Life Fitness-certified technician performs service work. Replacement of any strength cables should be performed by a Life Fitness certified technician.

Cable Terminations

1. Cable must be threaded at least 1/2 inch (12.7mm) into termination points; at headplate (A) and frame/carriage (B).

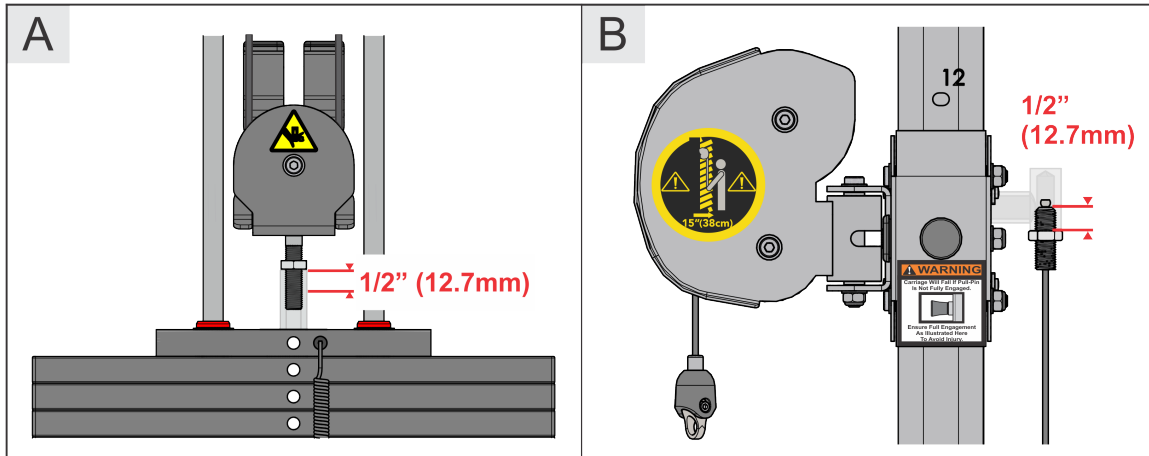

2. Certain models are now equipped with a bayonet portal to assist checking proper thread engagement. To do so, attempt to pass a 7mm Allen wrench through the portal, if it goes through, more threads are needed to meet the minimum requirement.

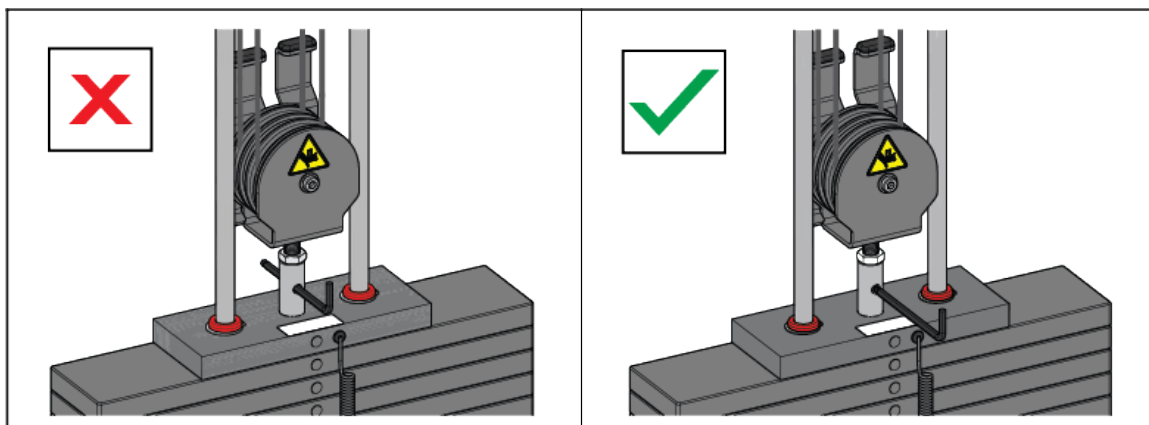

3. When proper thread engagement is reached, tighten jam nut to 20-25 FT-LBS (27.2 - 34.0 Nm) using a 24mm wrench.

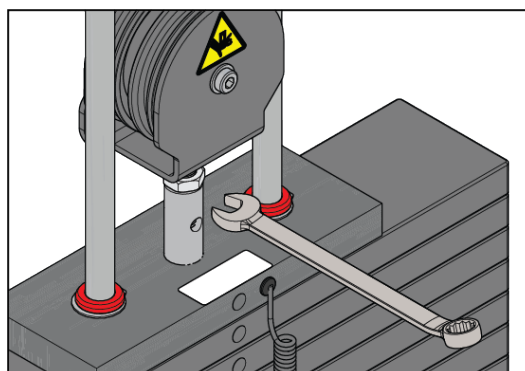

Tensioning Cable

Cable should have enough tension so it stays seated into the pulley but not so tight that it pulls the head plate off the weight plate below it.

1. If the head plate has lifted, loosen the jam nuts at the terminations and loosen the threaded plugs a half turn until the head plate comes to rest on the weight plate below. Check that the cable's threaded plugs are engaged at least 1/2" (12.7mm) at each termination point.

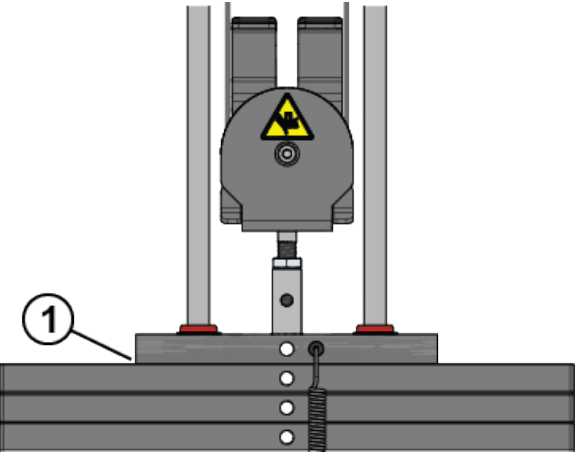
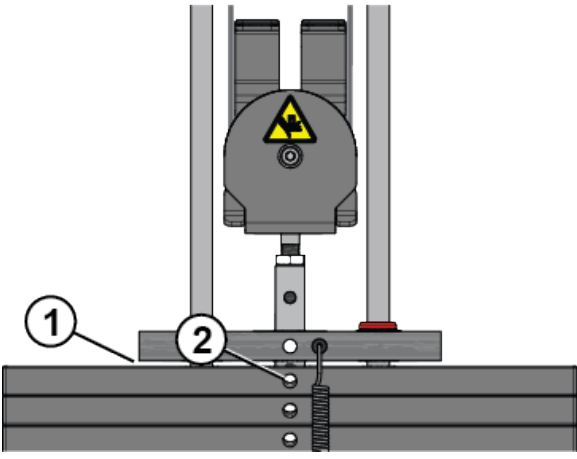
SEATED HEAD PLATE	SUSPENDED HEAD PLATE
	
<p>1. No gap</p>	<p>1. Gap 2. Bayonet obstructing weight stack pin</p>

2. Ensure that the weight stack selector pin can fully engage into each weight plate.

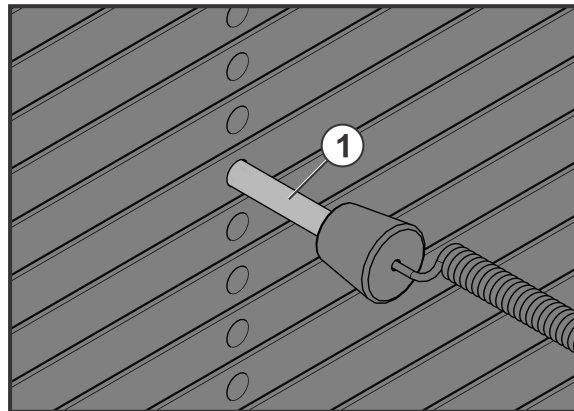

Item	Description	Qty.
1	Weight Stack Selector Pin	1

3. When proper thread engagement is reached, tighten jam nut to 20-25 FT-LBS (27.2 - 34.0 Nm) using a 24mm wrench.

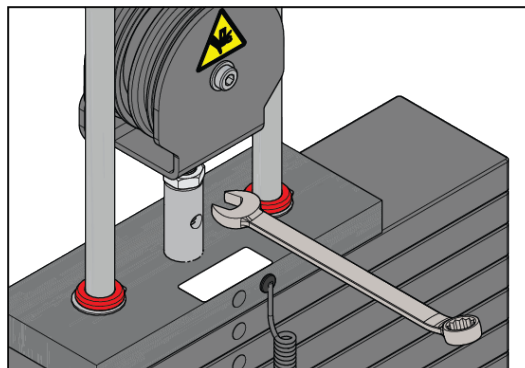

Strength Cable Wear Guide

Replace cable at first sign of any of the following:

FRACTURES:

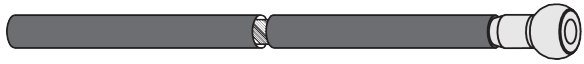
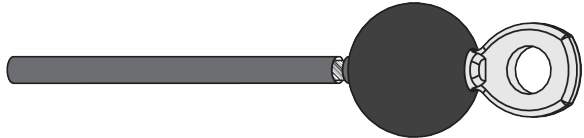
<p>Casing can crack or fracture under strains during use. Any crack in the casing merits cable replacement even if no wire rope is exposed.</p>	
<p>Be especially observant for fractures near the components on the cable assembly - IE. Nylon Ball, Nico Loop, Threaded Plug, etc.</p>	

TWISTING/BINDING:

<p>Inspect casing to ensure wire rope is not twisting within its casing. Any sign of the cable twisting should be replaced immediately.</p>	
---	--

BULGING:

<p>Internal wire rope strands can break within and coil causing a bulge to appear. Cable should retain same outside diameter throughout.</p>	
--	--

FRAYED/EXPOSED WIRE ROPE:

<p>Any exposed wire rope protruding through the casing or at either end.</p>	
--	--

FLATTENED:

<p>Section of cable is compressed and will not retain its shape (outside diameter).</p>	
---	--

PERMANENTLY BENT:

<p>Cable has 'kink' and prohibits cable from laying straight. Wire rope may be unraveling beneath casing and is compromised warranting replacement.</p>	
---	--

ENDS SEPARATING:

<p>Watch for component end of cable to pull away from cable assembly - look for exposed wire rope.</p>	
--	--

