



**Cybex MG 500 Multi-Gym  
Strength Systems  
Owner's and Service Manual  
Strength Systems  
Part Number 58600 D**





**Cybex MG 500 Multi-Gym  
Strength Systems  
Owner's and Service Manual  
Strength Systems  
Part Number 58600 D**

Cybex® and the Cybex logo are registered trademarks of Cybex International, Inc.

**DISCLAIMER:** Cybex International, Inc., makes no representations or warranties regarding the contents of this manual. We reserve the right to revise this document at any time or to make changes to the product described within it without notice or obligation to notify any person of such revisions or changes.

© Copyright 2008, Cybex International, Inc. All rights reserved.

Printed in the United States of America.

10 Trotter Drive Medway, MA 02053 • 508-533-4300 • FAX 508-533-5183

www.cybexinternational.com • techhelp@cybexintl.com • techpubs@cybexintl.com • 58600 D • October 2008



# Table of Contents

## i Table of Contents

### 1 Safety

|  |     |
|--|-----|
| Safety . . . . .                         | 1-1 |
| Warning/Caution Decals . . . . .         | 1-3 |
| Regular Maintenance Activities . . . . . | 1-9 |
| Using Proper Form . . . . .              | 1-9 |

### 2 Technical Specifications

|                                  |     |
|----------------------------------|-----|
| General Specifications . . . . . | 2-1 |
| Machine Specifications . . . . . | 2-4 |

### 3 General Exercise Guidelines

|                                |     |
|--------------------------------|-----|
| Training Suggestions . . . . . | 3-1 |
| Glossary . . . . .             | 3-2 |
| Exercise Charts                |     |

### 4 Exercises

|                                     |      |
|-------------------------------------|------|
| Hip Abduction . . . . .             | 4-2  |
| Hip Adduction . . . . .             | 4-2  |
| Hip Flexion . . . . .               | 4-3  |
| Hip Extension . . . . .             | 4-3  |
| Leg Extension . . . . .             | 4-4  |
| Seated Leg Curl . . . . .           | 4-5  |
| Standing Calf Raise . . . . .       | 4-6  |
| Seated Row . . . . .                | 4-6  |
| Front Lat Pulldown . . . . .        | 4-7  |
| Seated Rear Deltoid Row . . . . .   | 4-8  |
| Standing Shrugs . . . . .           | 4-8  |
| Decline Bench Press . . . . .       | 4-9  |
| Bench Press . . . . .               | 4-9  |
| Incline Bench Press . . . . .       | 4-10 |
| Military Press . . . . .            | 4-10 |
| Chest Press . . . . .               | 4-11 |
| Chest Fly . . . . .                 | 4-11 |
| Tricep Pressdown . . . . .          | 4-12 |
| Overhead Tricep Extension . . . . . | 4-12 |
| Standing Arm Curl . . . . .         | 4-13 |
| Hammer Curl . . . . .               | 4-13 |
| Wrist Curl . . . . .                | 4-14 |
| Abdominal Crunch . . . . .          | 4-14 |
| Seated Leg Press . . . . .          | 4-15 |
| Uni-Lateral Seated Row . . . . .    | 4-16 |
| Seated Calf Raise . . . . .         | 4-16 |

### 5 Customer Service

|                                  |     |
|----------------------------------|-----|
| Ordering Parts . . . . .         | 5-1 |
| Cybex Limited Warranty . . . . . | 5-2 |
| Delivery Inspection . . . . .    | 5-5 |
| Installation . . . . .           | 5-5 |
| Returning Goods . . . . .        | 5-6 |

### 6 Assembly

|   |       |
|---|-------|
| Tools Required . . . . .                  | 6-2   |
| Unpacking Main Frame Assembly . . . . .   | 6-2   |
| Installing Weight Stacks . . . . .        | 6-7   |
| Fly Station Diagram . . . . .             | 6-11  |
| Fly Station Assembly . . . . .            | 6-12  |
| Leg Press Diagram . . . . .               | 6-35  |
| Leg Press Assembly . . . . .              | 6-36  |
| Pressing Station Diagram . . . . .        | 6-57  |
| Pressing Station Assembly . . . . .       | 6-58  |
| Leg Extension/Leg Curl Diagram . . . . .  | 6-79  |
| Leg Extension/Leg Curl Assembly . . . . . | 6-80  |
| Cables Adjustments . . . . .              | 6-101 |
| Fly Station . . . . .                     | 6-101 |
| Leg Press Station . . . . .               | 6-102 |
| Leg Extension/Leg Curl Station . . . . .  | 6-103 |
| Pressing Station . . . . .                | 6-103 |
| Weight Stack Cable Check . . . . .        | 6-105 |
| Weight Stack Cable Adjustment . . . . .   | 6-106 |
| Final Assembly . . . . .                  | 6-107 |

### 7 Maintenance

|   |      |
|---|------|
| Daily Procedures . . . . .                                | 7-1  |
| Weekly Procedures . . . . .                               | 7-3  |
| Yearly Procedures . . . . .                               | 7-5  |
| “As Required” Procedures . . . . .                        | 7-5  |
| Cable Adjustments . . . . .                               | 7-5  |
| Fly Station . . . . .                                     | 7-6  |
| Leg Press Station . . . . .                               | 7-7  |
| Leg Extension/Leg Curl Station . . . . .                  | 7-8  |
| Pressing Station . . . . .                                | 7-8  |
| Weight Stack Cable Tension Check . . . . .                | 7-10 |
| Alternative Weight Stack Cable Tension<br>Check . . . . . | 7-10 |
| Weight Stack Cable Adjustment . . . . .                   | 7-11 |

### 8 Service

|                                    |     |
|------------------------------------|-----|
| Parts Lists and Diagrams . . . . . | 8-1 |
|------------------------------------|-----|



# 1 - Safety

## Safety

Read the Owner's Manual carefully before assembling, servicing or using the MG 500.

***! WARNING: Serious injury could occur if these safety precautions are not observed:***

- **DO NOT** use the MG 500 if it is not located on a solid level surface.
- Read all cautions/warnings and obtain proper instruction on use of the machine prior to using. Use appropriate positioning, speed and controlled movements.
- Obtain a medical exam prior to beginning an exercise program.
- If at any time during exercise you feel faint, dizzy or experience pain, stop and consult your physician.
- Keep head, limbs, fingers and hair clear of all moving parts.
- **DO NOT** wear loose or dangling clothing while using the MG 500. Keep away from all moving parts.
- Inspect the MG 500 prior to use. **DO NOT** use if damaged or inoperable.
- **DO NOT** attempt to fix a broken or jammed machine. Notify floor staff.
- Use the machine only for the intended use. Obtain instruction and **DO NOT** modify the machine.
- Be certain that the weight pin is completely inserted. Use only the pin provided by the manufacturer. If unsure, seek assistance.
- **NEVER** use dumbbells or other means to incrementally increase the weight resistance.
- **NEVER** pin the weights in an elevated position. **DO NOT** use the machine if found in this condition. Seek assistance from floor staff.
- Children must not be allowed near this machine. Teenagers must be supervised.
- **DO NOT** use if guards are missing or damaged.
- **DO NOT** remove any labeling from the MG 500. Replace any damaged labels.

## **Facility Safety Precautions**

- Make sure that the MG 500 is set up and always operated on a level surface.
- Read the Owner's Manual carefully before assembling, servicing or using the MG 500.
- Make sure that all users are properly trained on how to use the MG 500.
- Make sure there is enough room for safe access and operation of the MG 500. When the MG 500 is in use, there must be a minimum of at least three feet on all sides for safe access, operation and passage.
- Perform regular maintenance checks on the MG 500. Pay close attention to cables and their connections. Also pay close attention to all areas most susceptible to wear.
- Immediately replace worn or damaged components. If unable to immediately replace worn or damaged components then remove from service until the repair is made.
- Use only Cybox supplied components to maintain/repair the MG 500.
- Keep a repair log of all maintenance activities.

***NOTE:*** *It is the sole responsibility of the user/owner or facility operator to ensure that regular maintenance is performed.*

**Warning/Caution Decals**

Warning decals indicate a potentially hazardous situation, which, if not avoided, could result in death or serious injury.

Caution decals indicate a potentially hazardous situation, which, if not avoided, could result in minor or moderate injury.

The warning and caution decals are shown below and on the following pages. The diagrams following the decals show where each decal is located.

See Leg Press Station diagram, letter A.



See Fly Station and Leg Press Station diagrams, letter C.



See Fly Station diagram, letter B.

See Pressing Station diagram, letter D.

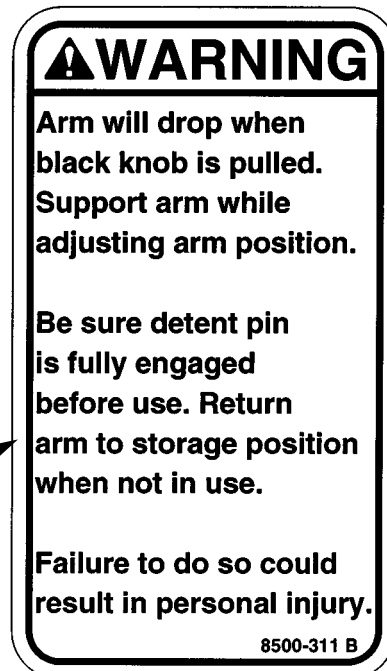

See Fly Station diagram, letter E.



See Pressing Station diagram, letter G.

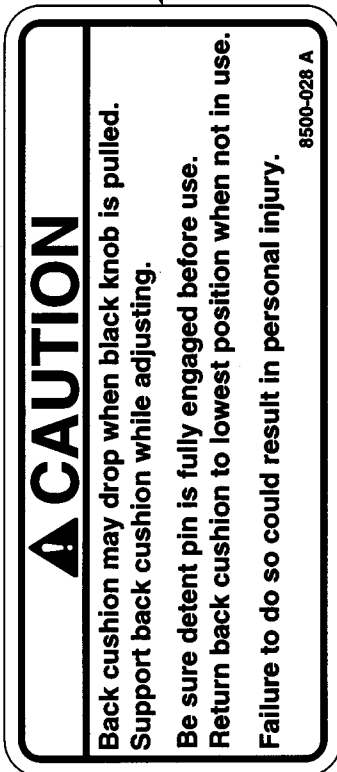

See Pressing Station diagram, letter F.

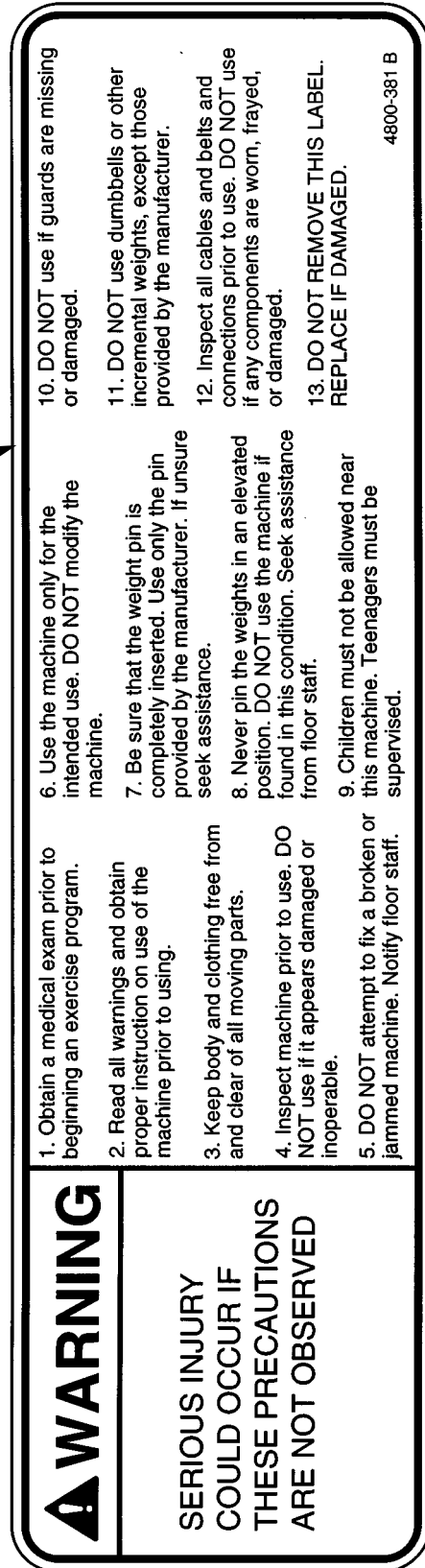

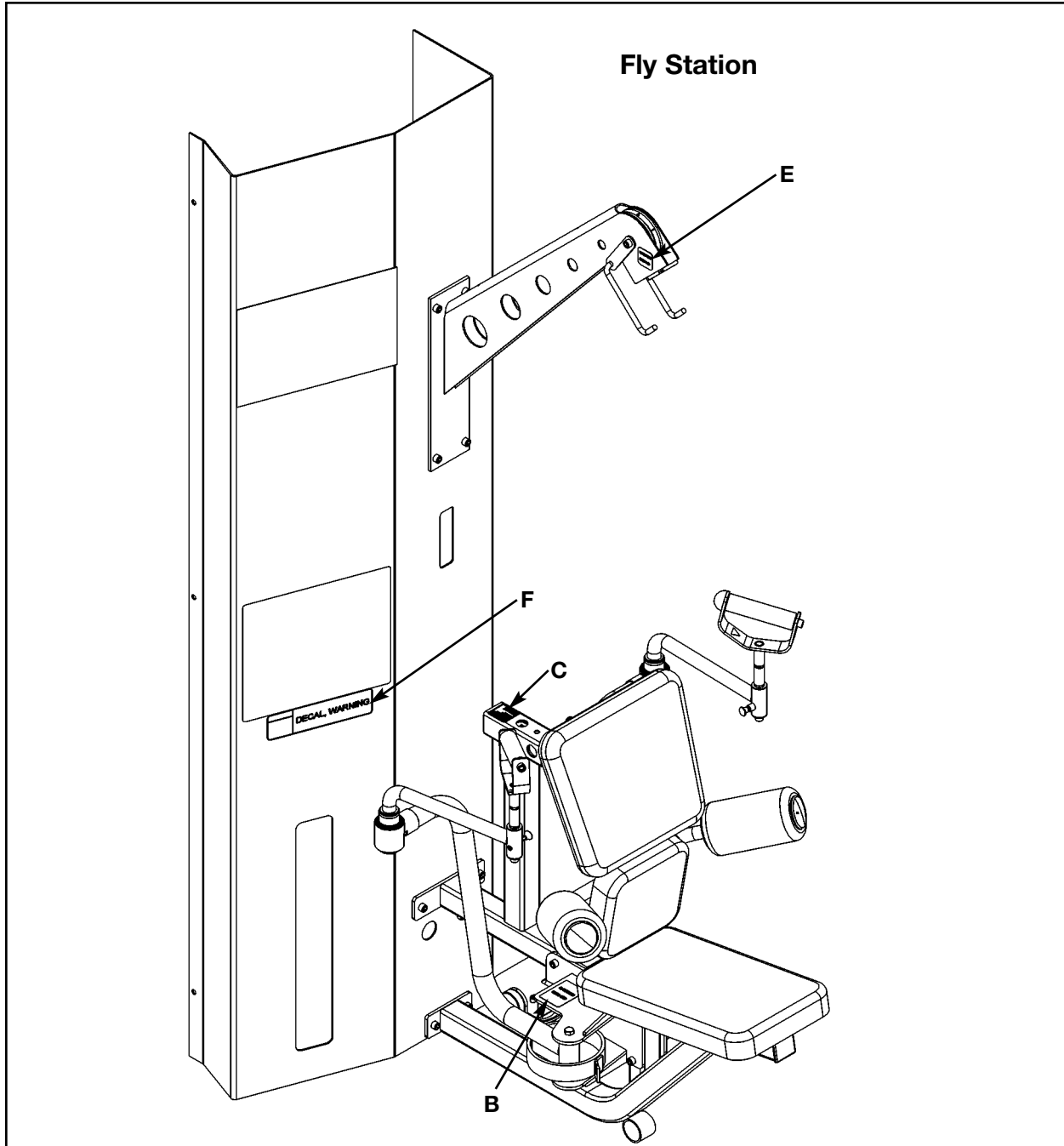

| DESCRIPTION                   | PART NO. |
|-------------------------------|----------|
| <b>B.</b> Caution Decal ..... | 8500-026 |
| <b>C.</b> Caution Decal ..... | 8500-025 |
| <b>E.</b> Warning Decal ..... | 8620-343 |
| <b>F.</b> Warning Decal ..... | 4800-381 |

**Leg Press Station**

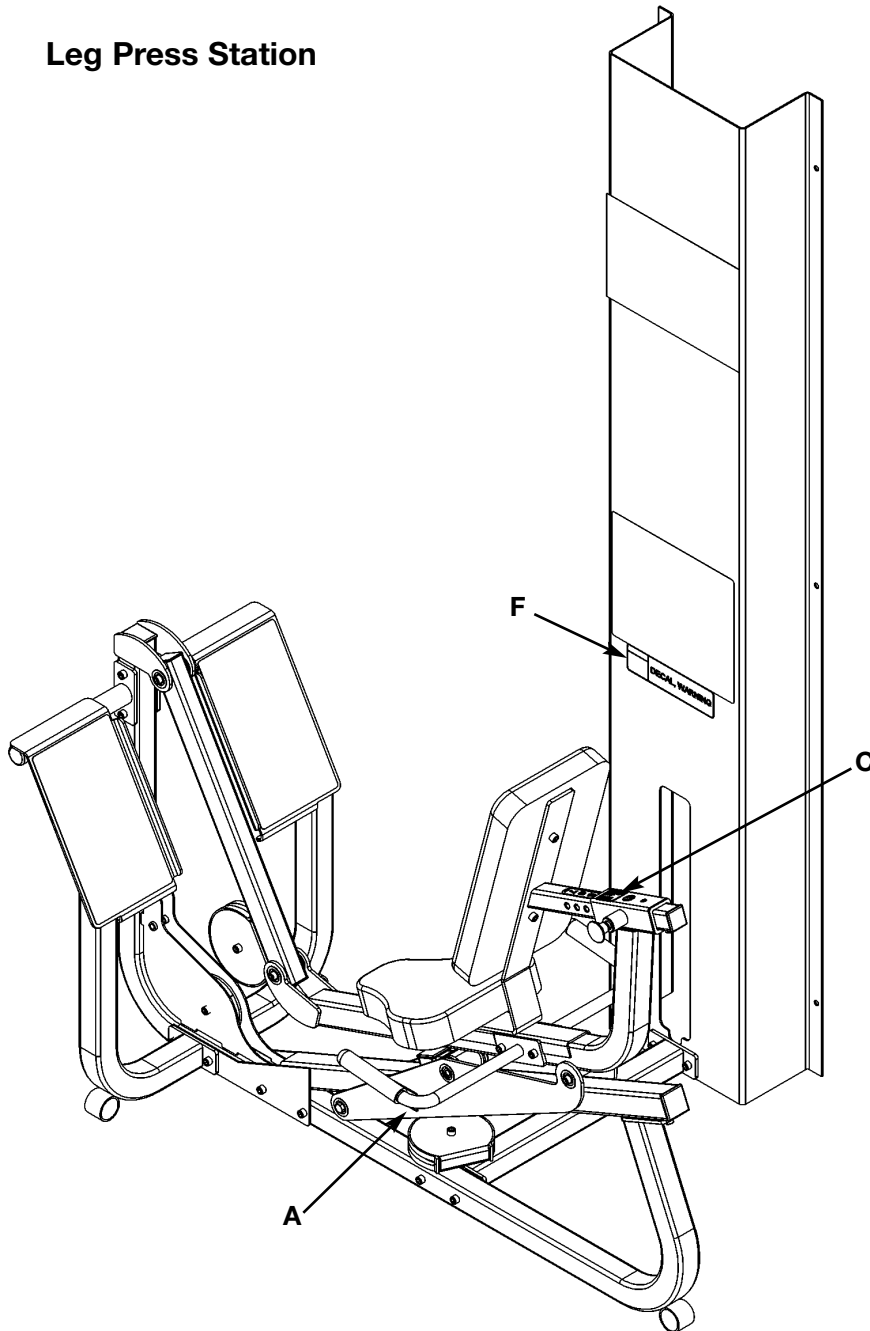

| DESCRIPTION            | PART NO. |
|------------------------|----------|
| A. Caution Decal ..... | 4000Y316 |
| C. Caution Decal ..... | 8500-025 |
| F. Warning Decal ..... | 4800-381 |

### Pressing Station

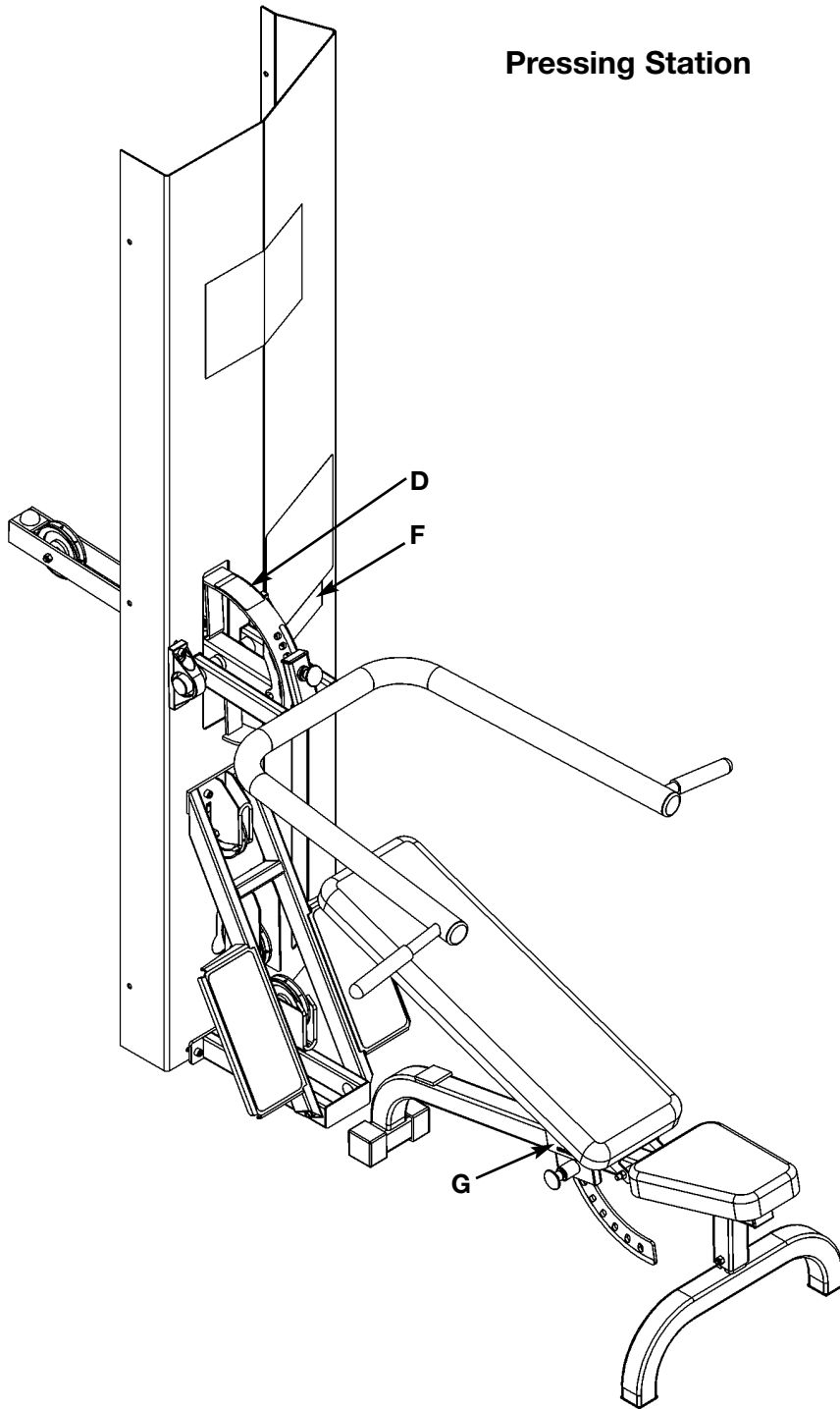

| DESCRIPTION            | PART NO. |
|------------------------|----------|
| D. Warning Decal ..... | 8500-311 |
| F. Warning Decal ..... | 4800-381 |
| G. Caution Decal ..... | 8500-028 |

**Leg Extension/Leg Curl Station**

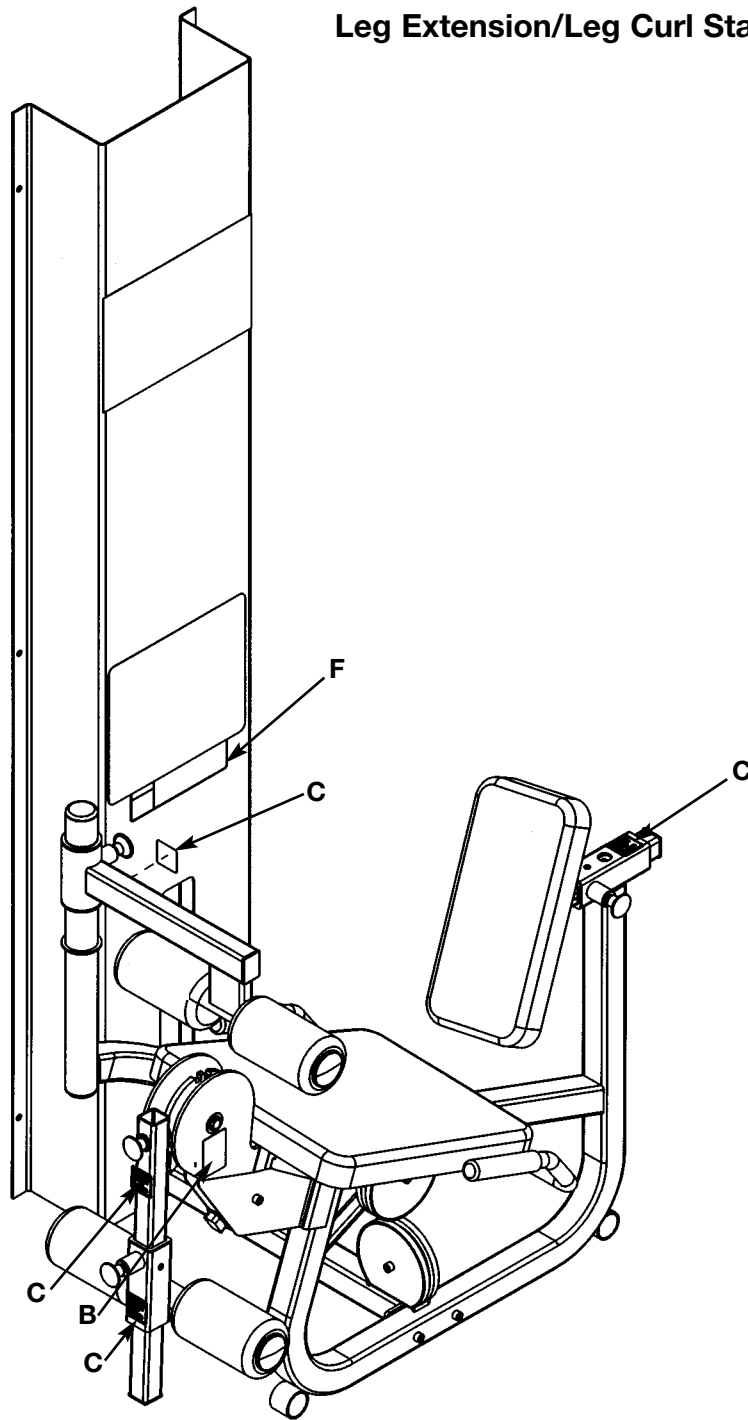

| DESCRIPTION            | PART NO. |
|------------------------|----------|
| F. Warning Decal ..... | 4800-381 |
| B. Caution Decal ..... | 8500-026 |
| C. Caution Decal ..... | 8500-025 |

## **Regular Maintenance Activities**

Preventative maintenance activities must be performed to maintain normal operation of your MG 500. Keeping a log sheet of all maintenance actions will assist you in staying current with all preventative maintenance activities. The preventative maintenance actions are described in detail in Chapter 7. Briefly, they include:

### **Daily**

1. Clean upholstery.

### **Weekly**

1. Inspect all nuts and bolts for looseness. Tighten as required.
2. Inspect all cables for damage or wear (see Chapter 7). **Immediately discontinue use if a cable is worn or damaged.**
3. Check for worn handles, worn snap links, and worn warning labeling. Replace all worn parts immediately.
4. Inspect weight stacks for proper alignment and operation. Correct all improper alignment and operation issues immediately.
5. Lubricate guide rods using automotive engine oil only.

### **Yearly**

1. Replace all cables at least annually.

### **As Required**

1. Inspect grips and replace as necessary.

## **Using Proper Form**

Before working out, read and understand the training suggestions listed in Chapter 3. See Chapter 4 for proper form during exercise.

***This page intentionally left blank***

## 2 - Technical Specifications

### General Specifications

#### Frame Finish

- Shall be made of mechanical quality 11 gauge and 16 gauge steel purchased in mill run quantities to assure the best consistency.
- Prior to applying finish, each part shall be put through a multi-stage wash to remove all oils and to chemically prepare the surface for maximum adhesion. After the wash, the frames shall be dried and coated with an Electrostatically applied powdercoat finish that shall be applied in powder form and then baked until cured.
- The finish shall be textured and very hard, assuring a scratch and chip resistant finish.

#### Weight Selection

- Weights are to be selected by using a high quality selector pin that completely penetrates the weight plate and locks in place to eliminate any chance of disengaging the pin during use. The pin shall be attached to the weight stack with a plastic lanyard in order that the pin stays with the appropriate machine. All weights shall be selected while the user is in position on/in the machine to allow adjustment of the resistance from the exercise position.

#### Weight Stacks Configuration

- All weight stacks shall have (4" x 12" x 1"), 12 1/2 pound weights.

#### Weight Plates

- Shall be made of solid cold-rolled steel with wrinkle black powder coat finish.
- Guide rod holes shall be machined to a tolerance of  $\pm .006$  inches.

#### Weight Plate Bushings

- Self-aligning low-friction bushings shall surround the guide rods for smooth gliding motion.

## **Pulleys**

- Shall use Dupont Corp. fiberglass-reinforced nylon 70G33 material, tensile strength rated at 22,500 PSI with 6203ZZ double sealed bearings dynamic load rated at 1600 lbs.
- Pulleys shall be 4.50 inches in diameter with a cable groove with a depth of .250 inches.

## **Weight Transport**

- Shall be lubricated, 7 x 19, 1/8" galvanized steel, nylon coated aircraft cable with breaking strength rated at 2000 pounds.
- All cable ends shall be finished off with a swaged fitting with a breaking strength exceeding that of the cable itself.

## **Weight Stack Guide Rods**

- Shall be solid ground and polished cold-drawn steel with minimum yield strength of 100,000 PSI with a hard chrome plated piston steel finish with an overall minimum accuracy of  $\pm .010$ .

## **Weight Stack Suspension**

- Shall have heavy-duty neoprene bumpers with an 80-durometer rating under the weight stacks to reduce shock and vibration stresses to the frame and facility.

## **Handgrips**

- Shall be closed-end PVC closed cell foam vinyl sleeve.

## **Frame Construction**

- Primarily 1 1/2 x 2" tubing with 11 gauge wall thickness, but different tubing sizes and wall thickness shall be used as required through engineering stress analysis.
- Shielding shall be 16 gauge wall thickness sheet metal.
- Fully welded frames for maximum structural integrity and minimum maintenance.
- All machining and welding must be done utilizing jigs and fixtures to insure highest quality and interchangeability of parts.

## **Radial Bearings**

- 87503 double shielded bearing with 17 mm stainless steel shafts, dynamic load rating 1660 lbs.

## **Hardware**

- All 3/8" socket head cap screws shall be of grade 8 (or equivalent). All bolts shall be either chromed or zinc plated for additional corrosion resistance.

## **Weight Stack Guards**

- All weight stacks shall be guarded on the backside to prevent bystanders from inadvertent contact with the weight stack during use.

## **Cushion/Upholstery**

- A superior grade of Boltaflex from Omnova shall be used on all pad covers and wear covers.
- The color shall be sulfide stain resistant.
- All edges shall be stitched to eliminate any folds in the material that would limit durability.
- Cushions come with replaceable slipcovers on all high use areas, reducing maintenance expense by not having to replace the entire cushion.
- Cushion foam consists of a combination of high and medium density closed-cell Omalon polyurethane, for durability and comfort.

## **Adjustments**

- Recessed high contrast Lexan decal for all seat and pad adjustments for maximum readability.

## **Instructional Placard**

- Shall provide step-by-step instructions and a picture to illustrate use, visible from the exercise position.
- Placard shall indicate proper positioning, and clearly describe the correct use of machines.

**Machine Specifications**

**MG 500 - Product No. 8600  
8602**

**Machine Weight**  
(includes weight stacks)  
1733 lbs.  
788 kg

**Three Weight Stacks**  
230 lbs. each  
105 kg

**Size**  
inches - 128 L x 74 W x 83 H  
cm - 325 L x 188 W x 211 H

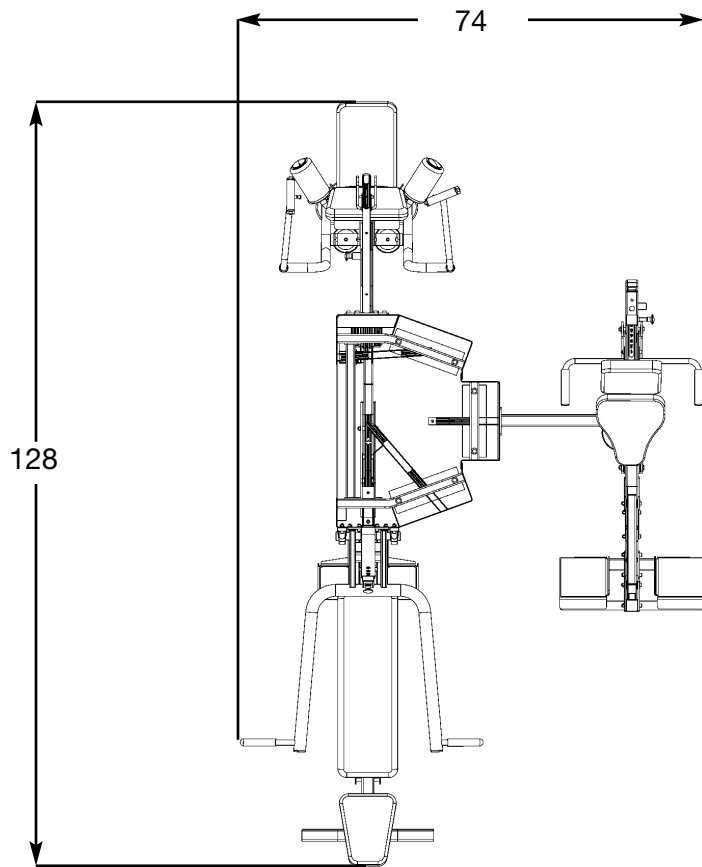

**Leg Press Configuration (8602)**

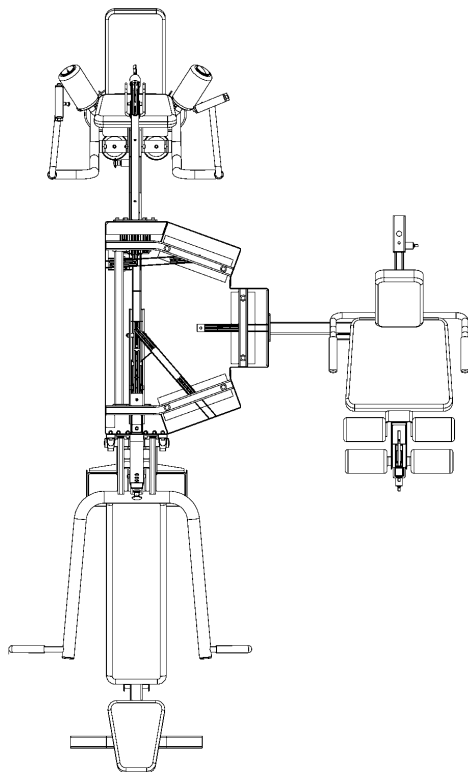

**Leg Extension Configuration (8600)**

## 3 - General Exercise Guidelines

### Training Suggestions

#### Before you workout

Prior to starting a training program, get a complete physical exam to make sure your physician agrees that you are ready. Always warm-up your muscles before a workout. A 5 - 10 minute cardio warm-up followed by slow stretching (no bouncing) is recommended. Continue with a lighter set (50% of normal of intended exercises. Proper breathing is very important. Exhale during muscle exertion, and inhale while returning to the start position. Start your program conservatively. Choose weights you can easily lift in the first weeks. Always perform the full range of motion unless you have an injury, then consult a professional trainer. Your Cybex dealer can help you find one. Know the terms? A "repetition" (rep) is defined as one complete movement through an exercise, returning to the start position. A "set" is a continuous series of reps usually between 6 - 15.

#### During your workout

The number of reps. you perform in a set depends on your goal. To build muscle and strength, do fewer reps (6 - 8) with heavier weight. To firm your muscles and build endurance, do more reps. (12 - 15) with lighter weight. Never "cheat" by shortening the range of motion, bouncing the weight, or shifting your posture. This may allow you to lift more weight, but it is dangerous and less effective. Catch your breath between sets, then continue. When "circuit training" move briskly to the next exercise; when doing multiple sets on one exercise, rest 45 - 90 seconds before the next set. Work up to three sets per exercise. When you can perform the desired reps and sets for any exercise, increase the weight by a half or full plate.

#### Designing your workout

Circuit training is a good way to start. This involves doing one set per exercise, then moving to the next exercise, pausing only briefly between them (to keep your heart and breath rate up) until completing a balanced "circuit" of 8 - 10 exercises for your entire body. Then repeat the circuit. After several weeks, you can move into multiple sets (3 in a row) per exercise if you choose. For both of these, exercise the complete body every other day, up to three times a week **Note:** *A full day's rest, plus proper nutrition and hydration are required for optimum muscle-building or toning.* Alternatively, work out half your body one day (e.g., the upper body) and the other half the following day (e.g. the lower body). To reduce muscle soreness, end each series of sets for a given muscle with a set of increased reps and lighter weights. At the end of your workout, cool down in a similar way to your warm-up.

**Glossary**

**Abduction** - movement away from the mid-line of the body.

**Acceleration** - the rate at which an object's velocity changes with time; that is the change of velocity divided by the time interval.

**Accuracy** - freedom from error. Degree of conformity of a measure to a standard or a true value.

**Action Line** - the direction of pull created by the fibers or tendons of the muscle at the point of application.

**Active Insufficiency** - a two joint muscle loses the ability to cross-bridge (generate force) due to full shortening over its greatest anatomical length and tension created in an opposing muscle (antagonist).

**Active Range of Motion** - the degree of motion that occurs between two adjacent segments through voluntary contraction of the agonist.

**Active Stabilization** - provided by an internal force. *Static* stabilization is provided through an isometric contraction where dynamic stabilization is a series of motions. *Dynamic* stabilizers maintain the relative positions of the segments, preventing undesirable or unnecessary motions due to external forces as well as artifacts of internal forces. May also refer to the concentric/eccentric contractions of a muscle acting in a force couple to produce motion while maintaining a relatively fixed axis of rotation.

**Adipose tissue** - fat tissue.

**Adduction** - movement towards the mid-line of the body.

**Agonist** - (prime mover) the muscle most involved in producing a movement.

**Aerobic** - utilizing oxygen.

**Aerobic Endurance** - the ability to persist in physical activities that rely heavily upon oxygen for energy production.

**Anabolic** - pertaining to the synthesis of complex substances from simpler substances, especially to the synthesis of body proteins from amino acids.

**Anaerobic** - without oxygen.

**Anaerobic Endurance** - the ability to persist in physical activities of short duration that require high rates of energy expenditure. These high rates of energy expenditure cannot be met solely by aerobic metabolism.

**Anthropometrics** - measurements and relationships of length and girth of body parts.

**Antagonist** - the muscle in opposition to the agonist.

**Anatomical Position** - standing erect, with feet and palms facing forward.

**Anatomical Pulley** - a bone or skeletal prominence that alters the direction of the pull of a muscle to increase the muscle's mechanical advantage.

**Anatomy** - geography, naming by orientation and/or apparent capability (non-functional).

**Anchor Points** - the points at which a load enters and exits the body and/or limb.

**Anterior** - anatomical term meaning towards the front. Same as ventral.

**Assistant Mover** - a muscle that is less effective at performing a specified motion, but does have a small degree of mechanical ability to help the prime mover. There are many borderline cases.

**Atrophy** - reduction in size of cells and tissues.

**Axis of Rotation** - imaginary line or point which an object rotates.

**Bilateral** - refers to both sides.

**Biocomotion** - a perspective/description of the human body and its mechanics based upon locomotion. All animals with legs (regardless of numbers) move with the same mechanics. Gravity is the common denominator.

**Biomechanics** - analysis of the load placed on a joint by both the muscle and resistance. Anatomy, Kinesiology, and Physics = Engineering.

**Body Composition** - the component parts of the body - mainly fat and fat-free weight.

**Calorie** - a unit of work or energy equal to the amount of heat required to raise the temperature of 1 g of water to 1 degree C.

**Cam** - a mechanical device used to vary leverage.

**Carbohydrate** - a chemical compound consisting of carbon, hydrogen and oxygen atoms in specified arrangements. Carbohydrates are major components of food such as bread, potatoes and rice.

**Cardiovascular** - pertaining to the heart and blood vessels.

**Cartilage** - there are several types. *Hyaline* cartilage is a relatively thin covering on the ends of many bones. It forms a smooth, resilient, low friction surface for the movement of one bone on another. Wedges of cartilage (fibrocartilage) called *menisci*, *disks* and *labrums* are to increase stability, provide shock absorption, and to facilitate motion in some joints.

**Center of Gravity** - the center of a body's mass. In the human body, it is the point which all parts are in balance with one another. The COG may be within the body, altered by the position of the body even to the point of being outside the body (pike position), or altered by the addition of load to specific body areas.

**Circumduction** - a circular movement permitted at ball and socket, condylar and saddle joints. Consists of flexion, abduction, extension and adduction in sequence.

**Circuit Training** - a conditioning program consisting of a number of exercises performed at "stations". Usually, a given exercise is performed at a station within a specified time; then the athlete moves to the next station, with its own particular exercise and specified time, then to the next station, and so on.

**Closed Chain Kinetic Exercise** - a series of rigid links interconnected by a series of pincentered joints. These are constructed so that motion at one joint will produce motion at all the joints in the system. Produces greater mechanical efficiency at the risk of increased joint loading. Leg press, bench press.

**Close-Packed Position** - all synovial joints have a position where joint surfaces are maximally congruent and the ligaments and capsule are maximally taut.

**Collagen** - a fibrous protein that serves as the major component of ligaments and tendons.

**Compression** - two forces acting along the same line towards each other that constitute a compressive load or compressive stress.

**Concentric action** - contraction of a muscle resulting in shortening of the muscle.

**Connective Tissue** - comprised of mostly the proteins collagen and elastin with water; includes tendons, ligaments, bursae, cartilage, disks, menisci, fascia and bone.

**Cross-bridge** - the connection and intertwining of the actin and myosin filaments in a myofibril relative to a muscular contraction.

**Curvilinear Motion** - the frequently occurring combination of rotatory and translatory motions.

**Distraction** - two forces acting along the same line and in opposite directions, they constitute a distractive, tensile load or tensile stress.

**Diathrodial Joint** - ball and socket joint.

**Distal** - furthest from the attached end of the limb; away from the body.

**Dorsal** - pertaining to the back; opposite of ventral, palmar or plantar.

**Dorsiflexion** - movement of the foot up in the sagittal plane; movement toward the leg.

**Eccentric** - muscle action in which tension is developed in the muscle while it is lengthening. *Negative* work is performed.

**Eccentric Action** - a muscle contraction incapable of overcoming the resistance imposed; the overall muscle length increases.

**Endurance** - the ability to persist in performing some physical activity.

**Energy** - the capacity to perform work.

**Energy (kinetic)** - energy associated with motion.

**Energy (potential)** - energy by virtue of position.

**Energy System** - one of three metabolic systems involving a series of chemical reactions resulting in the formation of waste products and the manufacture of ATP.

**Eversion** - movement of the sole of the foot outward; opposite of inversion.

**Extension** - movement at a joint, bringing two parts into or towards a straight line, increasing the angle of the joint. Returning to anatomical position from a position of flexion in the sagittal plane.

**External Force** - a push or pull on the body that arises from a source outside the body.

**External Rotation** - movement of the anterior surface of a segment away from the mid-line; also termed lateral rotation.

**Fast-twitch Fibers** - skeletal muscle fibers most active in short-duration, intensive exercise, e.g., in sprints and jumps.

**Fatigue** - the inability to maintain a given level of physical performance.

**Flexibility** - the range of movement of a specific joint or group of joints, influenced by the associated bones and bony structures, muscles, tendons and ligaments.

**Flexion** - movement about a joint in which bones on either side of the joint are brought closer together, decreasing the angle of the joint. Joint movement away from anatomical position, occurring within the sagittal plane.

**Foot-pound** - the work required to move one pound of resistance one foot in distance.

**Force** - an interaction between two objects, in the form of a push or pull, that may or may not produce motion, Force = mass x acceleration.

**Force Angle** - (FA) the angle between the action line and the lever, on the side of the joint axis.

**Force Couple** - concentric/eccentric contractions of opposing muscles acting to produce motion while maintaining a relatively fixed axis of rotation.

**Frontal Plane** - (coronal) imaginary line that divides the body into anterior and posterior halves; lies at a right angle to the sagittal plane.

**Fulcrum** - the support on which a lever rotates in moving or lifting.

**Hyperextension** - continuation of the movement of extension past the neutral position.

**Hypertrophy** - increased cell size leading to increased tissue size.

**Impulse** - the change in momentum.

**Inertia** - the tendency of a body to remain at rest or continue in motion unless disturbed by an external force.

**Inferior** - a lower position upon or within the body.

**Insertion** - the more distal attachment site of a muscle. The movable part or attachment of a muscle as opposed to origin.

**Intermittent Work** - work sessions interrupted by rest sessions.

**Internal Forces** - act on the body and arise from sources within the human body.

**Inversion** - moving the sole of the foot inward. Opposite of eversion.

**Isokinetic** - action in which the rate of movement is constantly maintained through a specific range of motion even though maximal force is exerted.

**Isokinetic Contraction** - a muscular contraction through a range of motion at a constant velocity.

**Isometric** - a contraction in which movement is produced but no movement occurs.

**Isometric (static) Contraction** - a muscular contraction in which there is no change in the angle of the involved joint(s) and little or no change in the length of the contracting muscle.

**Isotonic** - a contraction in which movement is produced.

**Medial Rotation** - movement around an axis and toward the mid-line of the body. Also termed internal rotation.

**Moment Arm** - (MA) the shortest distance between the action line and the joint axis.

**Momentum** - determined by mass x velocity. Will remain constant unless the object is acted upon by another force.

**Muscle Contraction** - shortening of a muscle and/or development of tension in a muscle.

**Muscular Endurance** - the ability of a muscle or muscle group to perform repeated contractions against a light load for an extended period of time.

**Neutral** - a point between the two extremes of a joint's range of motion.

**Obesity** - excess body fat.

**Open Kinematic Chain** - the ends of the limbs are free to move without causing motion at another joint. Open chain motions are not predictable because the joints may function either independently or in unison. Less mechanically efficient, therefore more stress is placed upon muscular tissue.

**Origin** - attachment of a muscle that remains relatively fixed during muscular contraction.

**Overload** - to exercise a muscle or muscle group against resistance greater than that which is normally encountered. The resistance (load) can be maximal or near-maximal.

**Passive Insufficiency** - a two-joint muscle loses the ability to cross-bridge (generate force) due to full lengthening over its greatest anatomical length due to force created in an opposing muscle.

**Passive Stabilization** - due to noncontractile components. *Internal* stabilization is created by connective tissue (muscular support is not provided anatomically or physiologically) and *external* stabilization is provided by a bench or brace.

**Plane of Motion** - a two-dimensional flat surface running through an object. Motion occurs in the plane or parallel to the plane.

**Plantar** - anatomical term referring to the sole or bottom.

**Plantarflexion** - movement of the foot down in the sagittal plane; movement away from the leg.

**Posterior** - anatomical term meaning toward the back. Opposite of anterior.

**Potential Energy** - energy by virtue of position.

**Power** - the product of force and velocity. Work divided by time.

**Prime Mover** - (agonist) a muscle that is mechanically optimal to produce a specific motion at a joint. There can be more than one prime mover for a particular motion and a specific muscle can be a prime mover for more than one motion at a joint.

**Progressive Resistance** - overloading a muscle or muscle group consistently throughout the duration of a weight-resistance program.

**Pronation** - a triplanar motion at the subtalar joint consisting of abduction, depression and eversion, resulting in lowering of the longitudinal arch of the foot. Position of the forearm with the palm facing down.

**Protein** - a basic foodstuff containing amino acids.

**Proximal** - towards the attached end of the limb or origin.

**Range of Motion** - the amount of motion available to a joint within the anatomical limits of the joint structure. Can be classified as *Passive* (movement produced via a force outside the limb), *Active* (movement produced by muscles within the limb) or *Resisted* (movement challenged under additional load). The amount of resistance will affect the range of motion with direct proportion.

**Reciprocal Inhibition** - contraction of agonist causes relaxation of antagonist.

**Reliability** - the extent to which an experiment, test or measuring procedure yields the same results on repeated trials. Also known as reproducibility or repeatability.

**Repetition Maximum (RM)** - the maximum load that a muscle or muscle group can lift in a given number of repetitions before fatiguing. For example, an eight-RM load is the maximum load that can be lifted eight times.

**Repositioners** - muscles that lift the extremity and move it to a new location allowing the prime movers to again accept load or propel.

**Response** - a sudden temporary adjustment in physiological function brought on by a single exposure to exercise, e.g., the rise in heart rate associated with an exercise bout.

**Rotary Motion** - (radial or angular) the movement of an object around a fixed axis in a curved path.

**S.A.I.D. Principle** - Specific Adaptation to Imposed Demand. A muscle will gain strength in the specific ranges of motion and speeds in which it is trained.

**Sagittal Plane** - Imaginary line that divides the body, or any of its parts, into right and left sections.

**Scoliosis** - a lateral curvature of the vertebral column, usually in the thoracic area.

**Secondary Joint** - hinge joints that have a singular function (elbow/knee). Muscles are situated on either side of these joints in virtual, if not real, pairings.

#### General

#### Exercise Guidelines Page 3-8

**Set** - in an interval training program, a group of work and relief intervals. In weight lifting, the number of repetitions performed consecutively without resting.

**Shear** - two parallel forces applied in opposite directions that are not in line with each other constitute a shearing load or stress. The site of muscular attachment is the axis around which the forces of shear develop. This becomes the "force axis" as opposed to the anatomical axis.

**Shunt Muscle** - directs the greater part of its contractile force along the bone it is moving (creating greater force towards compression/stabilization). The brachioradialis is a shunt during an arm curl.

**Skeletal Muscle** - muscle controlling skeletal movement that is normally under voluntary control.

**Skewing** - the result of a vector shift through a limb or system.

**Sliding Filament Theory** - a muscle shortens or lengthens because the thick and thin myofibrils slide past one another without the filaments changing length.

**Slow-twitch Fibers** - skeletal muscle fibers characterized by relatively slow contraction times and great capacity for the aerobic production of adenosine triphosphate.

**Sprain** - the permanent deformation of the structure due to excessive or prolonged stress/strain.

**Spurt Muscle** - directs the greater part of its force across the bone it is moving rather than along it (creating greater effort towards motion). The biceps is a spurt during an arm curl.

**Stabilizer** - a muscle that steadies or supports a joint in order that another active muscle may have a firm base upon which to pull.

**Static contraction** - a muscular contraction that does not involve changes in the angle of the joint(s) involved.

**Steady state** - that state of physiological stability wherein the energy demands of the body can be met relatively easily for a prolonged period of time.

**Strain** - the deformation of the structure as the result of stress.

**Strength** - the ability to exert muscular force briefly.

**Stress** - the force created within a structure when placed under load.

**Submaximal exercise** - usually exercise at less than maximal intensity, but may also refer to exercise of less than maximal duration.

**Superior** - a higher position upon or within the body.

**Synergist** - occurs during the action of two muscles, both of which have a common joint action and each of which has a second action that is antagonistic or opposing to the other. True synergy is simply the stabilization of one muscle to prevent any action in one of the joints traversed by a multi-joint muscle.

**Synovial Fluid** - transparent, viscous lubricating fluid found in joint cavities, bursae and tendon sheaths.

**Tendons** - cords of dense fibrous tissue that connect muscle to bone.

**Tertiary Joint** - a complex joint structure (wrist/ankle-subtalar), designed for finely controlled movements.

**Torque** - the ability of a force to produce movement around an axis.

**Training** - a program of exercise designed to improve the skills and increase the energy capacities of an athlete for a particular event.

**Translatory Motion** - (linear) the movement of an object in a straight line.

**Unilateral** - refers to only one side.

**Validity** - the extent to which a measurement or information is relevant or meaningful; appropriate to the end in view and supported by objective truth.

**Vector** - an arrow which represents a force's point of application, action line or direction indicating pull or magnitude of force being exerted.

**Vector Shift** - the alteration of a load as it is transferred between the anchor points through a segment's kinematic chain.

**Velocity** - the rate at which an objects position changes with time; that is the total change in position divided by the total change in time:  $V=d/t$ .

**Weight** - the weight of an object is the gravitational force exerted on it by the earth.  $W=mg$ , where  $g$  = gravitational acceleration.

**Work** -  $W = Fd$ . The amount of work performed is equivalent to the force applied to an object times the distance the object is moved.









# 4 - Exercises

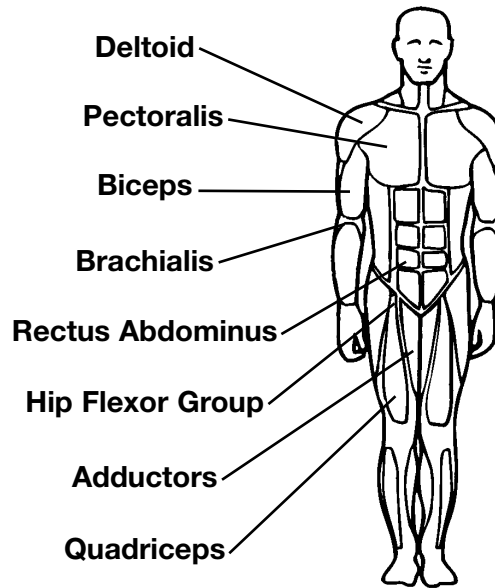
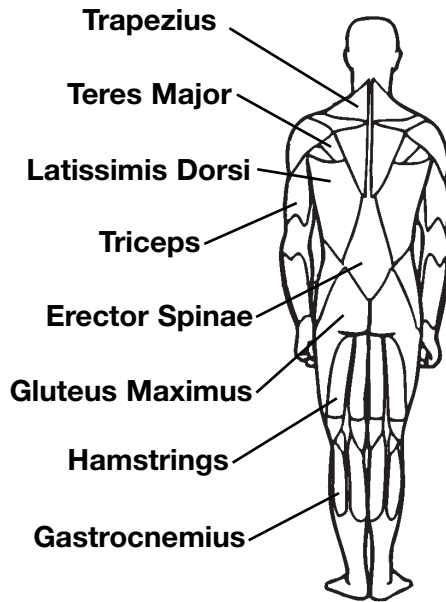
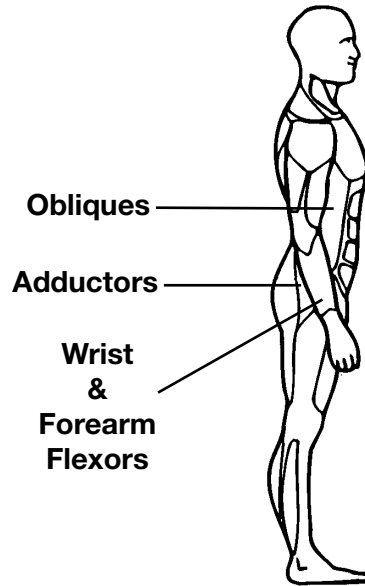

Read and understand all instructions and warnings prior to using equipment.

**Note:** See the general training suggestions in Chapter 3 and all of the safety related information located in Chapter 1.

### **Hip Abduction**

Emphasis: Gluteus Medius

1. Attach ankle strap to swivel low-pulley and adjust pressing arm to waist height for stability.
2. Wrap strap just above ankle around leg to be exercised.
3. Place the exercising leg in front of the stationary leg while maintaining tension in the cable.
4. Stand erect with slight bend in knees and brace your position with inside arm against the pressing arm.
5. Exhale while lifting the working leg slowly across and away from the body to approximately 45 degrees. This is your maximum range of motion.
6. Inhale when returning to the starting position.

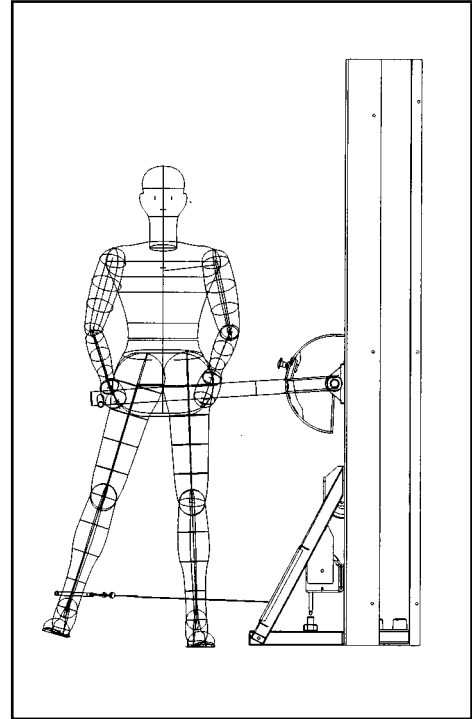

### **Hip Adduction**

Emphasis: Hip Adductors

1. Attach ankle strap to swivel low-pulley and adjust pressing arm to waist height for stability.
2. Wrap strap just above ankle around leg to be exercised.
3. Place the exercising leg in front of the stationary leg while maintaining tension in the cable.
4. Stand erect with slight bend in knees and brace your position with inside arm against the pressing arm.
5. Exhale while lifting the working leg slowly across and away from the body to approximately 20 degrees past midline. This is your maximum range of motion.
6. Inhale when returning to the starting position.

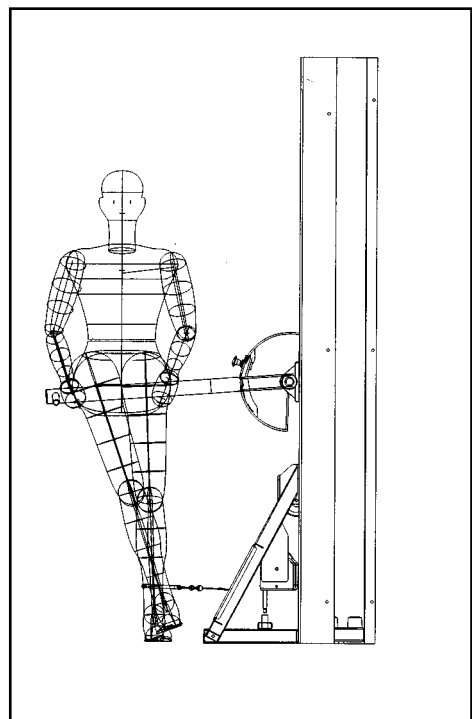

### **Hip Flexion**

Emphasis: Hip Flexors, Rectus Femons and Sartonus

1. Attach ankle strap to swivel low-pulley and adjust pressing arm to waist height for stability.
2. Wrap strap just above ankle around leg to be exercised, facing away from the machine.
3. Stand erect with slight bend in knees and brace your position with hands on the pressing arm.
4. Exhale while lifting the working leg slowly up and away from the body to approximately 90 degrees in front of you. This is your maximum range of motion.
5. Inhale when returning to the starting position.

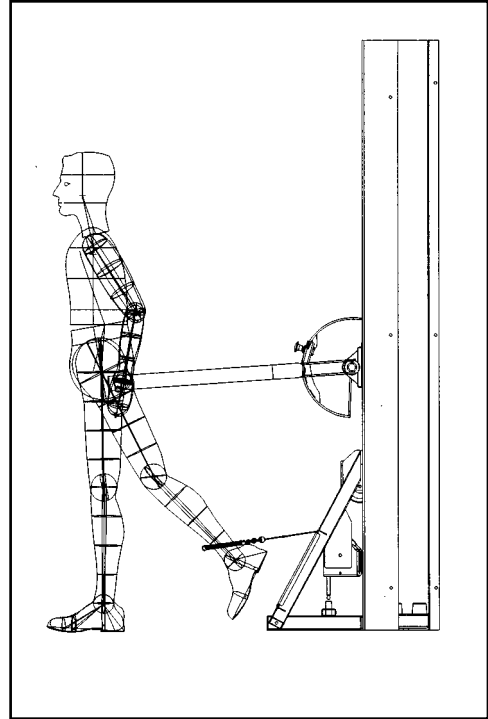

### **Hip Extension**

Emphasis: Gluteus Maximus, Hamstrings

1. Attach ankle strap to swivel low-pulley and adjust pressing arm to waist height for stability.
2. Wrap strap just above ankle around leg to be exercised, facing the machine.
3. Stand erect with slight bend in knees and brace your position with hands on the pressing arm.
4. Exhale while lifting the working leg slowly back and away from the body to approximately 15-20 degrees behind you. This is your maximum range of motion.
5. Inhale when returning to the starting position and repeat with the opposite leg.

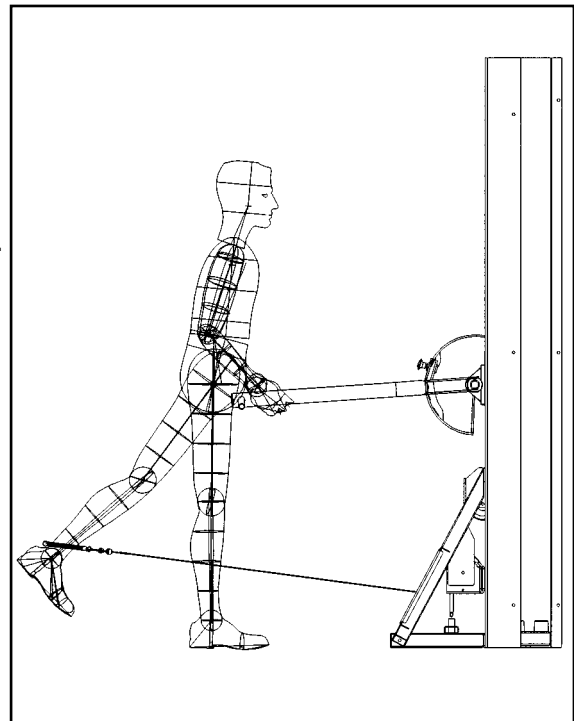

## Leg Extension

**Note:** The Leg Extension/Seated Leg Curl Station performs two exercises: Leg Extension and Seated Leg Curl.

To adjust machine from Seated Leg Curl to Leg Extension Follow steps 1-5.

1. Pull detent pin at machine's axis of rotation, lowering lower arm into one of the two below positioned slots.
2. Adjust thigh pad bar so that thigh pads out off to the side.
3. Be sure that all detent pins are securely in place and adjustments are at the desired height.
4. Place feet under lower leg pads.
5. Grip hand grips lightly to help stabilize body during the exercise.

Emphasis: Quadriceps

1. Select appropriate resistance.
2. Adjust back pad so that knees are in line with machine's axis of rotation.
3. Sit upright and grasp handles to stabilize your body.
4. Tighten quadriceps and slowly extend lower legs with a smooth motion. Pause while extended and slowly return to starting position.

**NOTE:** On the first rep. further align knees by rotating thighs so knee-cap is directly on top of knees. Maintain this position through each rep.

**NOTE:** Minimum resistance that may be selected for this exercise is two plates - approximately 25 lbs.

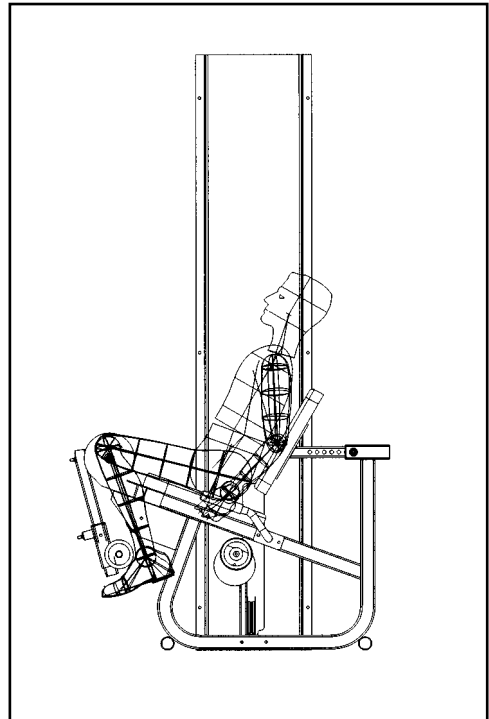

## Seated Leg Curl

To adjust machine from Leg Extension to Seated Leg Curl follow steps 1-4.

1. Pull detent pin at machine's axis of rotation, raising lower arm into one of the two above positioned slots.
2. Adjust thigh pads to control unwanted movement of upper legs during exercise.
3. Be sure that all detent pins are securely in place and adjustments are at the desired height.
4. Grip handles tightly to help stabilize body during exercise.

Emphasis: Hamstrings

1. Select appropriate resistance.
2. Adjust back pad so that center of knees aligns with rotation point of machine.
3. Adjust height of lower leg pads to a height comfortably above ankles.
4. Lift/lower resistance with smooth controlled movements without resting.

**NOTE:** *On the first rep. ensure that knees are correctly positioned by rotating your thighs, so that knee caps point upward. Maintain this position through each rep.*

**NOTE:** *Minimum resistance that may be selected for this exercise is two plates - approximately 25 lbs.*

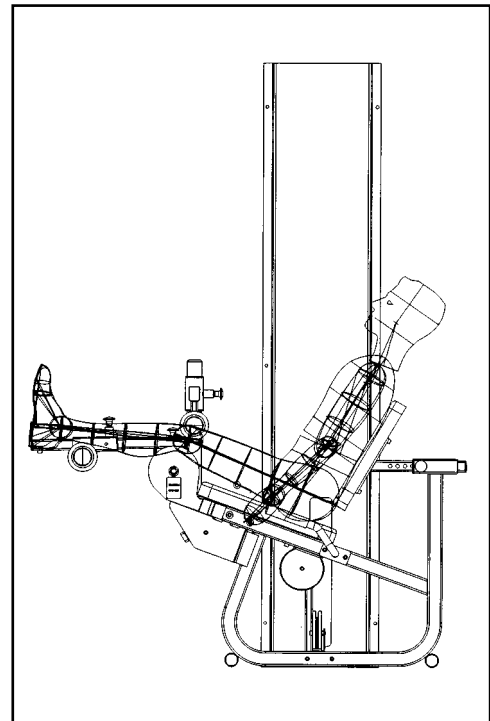

### Standing Calf Raise

Emphasis: Gastrocnemius, Soleus

1. Adjust pressing-arm height so that weight stack is suspended about 4" when in standing position.
2. Firmly grasp handles and position feet shoulder width apart.
3. Keeping your arms and back straight, lift pressing arm.
4. Keeping the back straight, hips tucked in and knees over toes, raise heels as far as possible with a smooth continuous motion.
5. Do not hyperextend (lock) knees during movement.

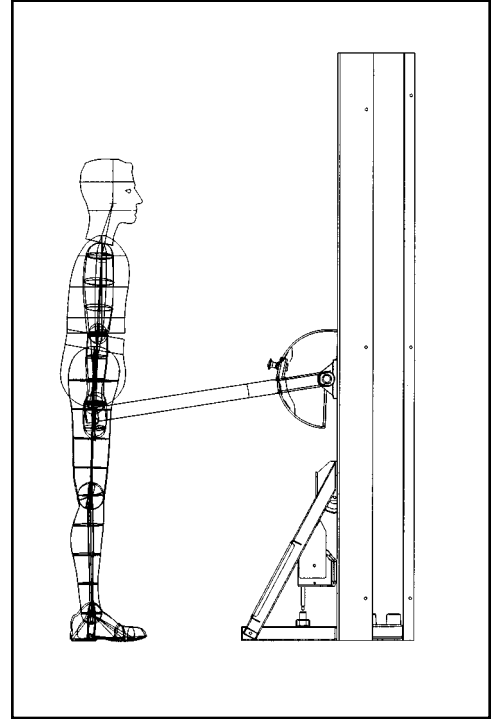

### Seated Row

Emphasis: Latissimus Dorsi, Teres Major, Trapezius, Brachioradialis

1. Lower the pressing station arm into the bottom position and attach the seated row handle.
2. Slide the adjustable bench into the pressing station and set on position 1, allowing easy access to foot rests.
3. Place feet on rests and keep back straight. Bend forward at the hips and grasp handle. Maintaining an upright position, pull toward abdomen.
4. Pinch shoulder blades back to maximize stability and effectiveness.

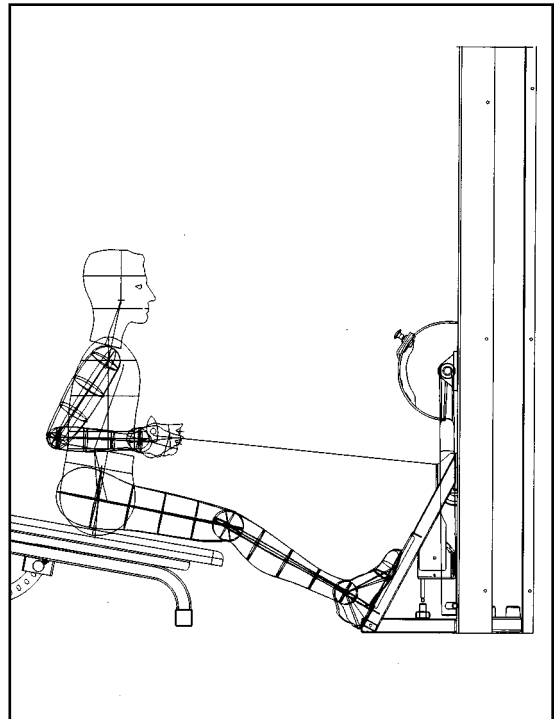

## Front Lat Pulldown

Emphasis: Latissimus Dorsi and Teres Major

1. Adjust seat back so thigh support pads are positioned comfortably.
2. Using an overhead grip, bend the elbows to 90 degrees and place a firm grip on the bar. This hand width will be optimal for your motion.
3. Sit down placing legs under thigh pad and lean back slightly.
4. Exhale while putting elbows toward your side. The bar should travel to top of chest but not lower.

**NOTE:** Although frequently performed, the pulldown "behind the neck" is far less effective and is not recommended due to the stress it places on shoulders. A good variation is to perform the front pulldown with the low row handle, using the same form.

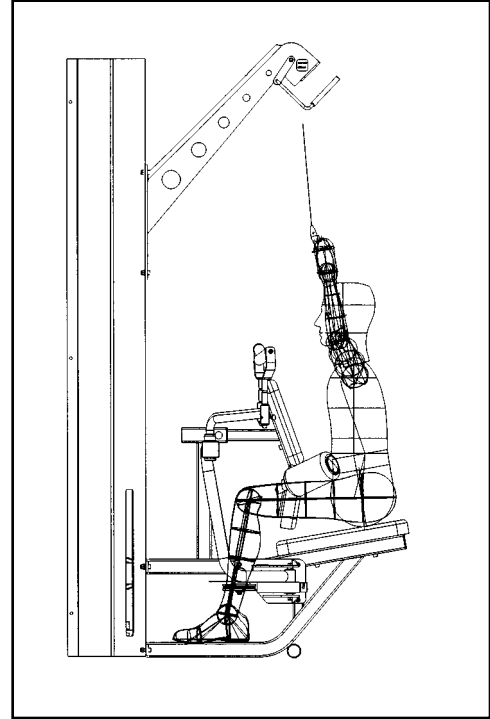

### Seated Rear Deltoid Row

Emphasis: Rear Deltoid,  
Trapezius, Erector Spinae,  
Brachioradialis

1. Lower the pressing station arm into the bottom position and attach the lat pulldown handle.
2. Slide the adjustable bench into the pressing station and set on position 1, allowing easy access to foot rests.
3. Place feet on rests, keep back straight, bend forward from the hips, and grasp handle. Sitting upright, pull bar toward chest, keeping the elbows slightly below shoulder level.
4. Be sure to pinch the shoulder blades back to maximize stabilization and effectiveness, pull upward.

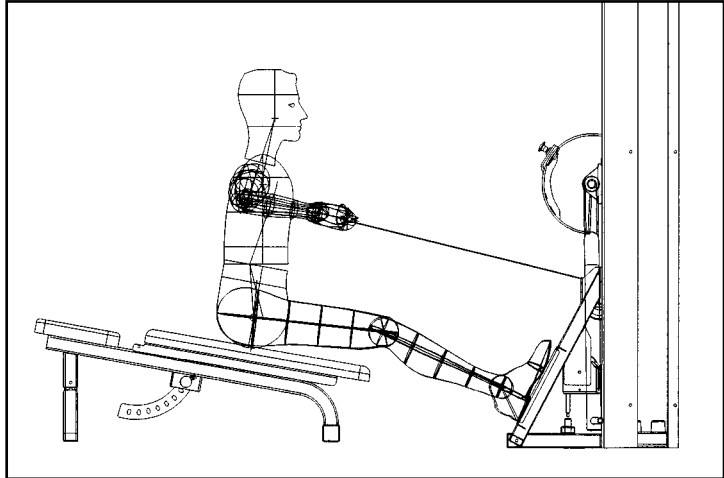

### Standing Shrugs

Emphasis: Upper Trapezius

1. Adjust pressing arm to slightly below waist level, bend at the knees, and grasp handles.
2. Stand erect, keep arms straight, elevate the shoulders up, and back toward the base of the head.

**NOTE:** Although commonly performed, do not "roll" the shoulders during the shrugs. That movement is less effective and could potentially injure the shoulder.

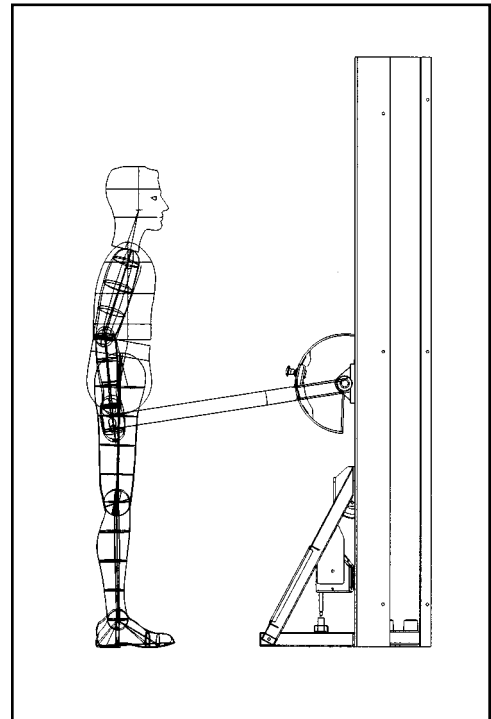

**Decline  
Bench Press**

(BENCH POSITIONS 1 - 2)

Emphasis: Pectoralis Major, Anterior Deltoid, Triceps

1. Slide the adjustable bench into the pressing station and align the handles at midchest.
2. Adjust the pressing arm to the desired range of motion. The upper arm should not be below parallel with the floor.
3. Pinch shoulder blades down and back to stabilize the spine and maximize effectiveness.
4. Position feet firmly on the floor for increased stability.
5. Inhale as you lower the weight and exhale as you press upward.

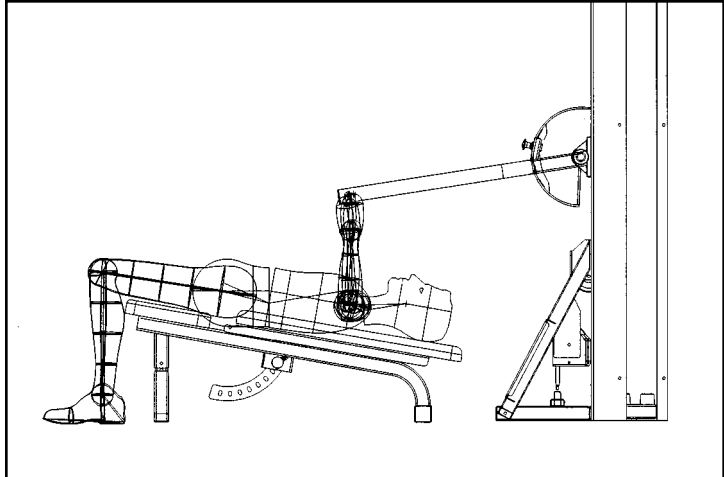

**Bench Press**

(BENCH POSITIONS 3 - 5)

Emphasis: Pectoralis Major,  
Anterior Deltoid,  
Triceps

1. Slide the adjustable bench into the pressing station and align the handles at midchest.
2. Adjust the pressing arm to the desired range of motion. The upper arm should not be below parallel with the floor.
3. Pinch shoulder blades down and back to stabilize the spine and maximize effectiveness.
4. Position feet firmly on the floor for increased stability.
5. Inhale as you lower the weight and exhale as you press upward.

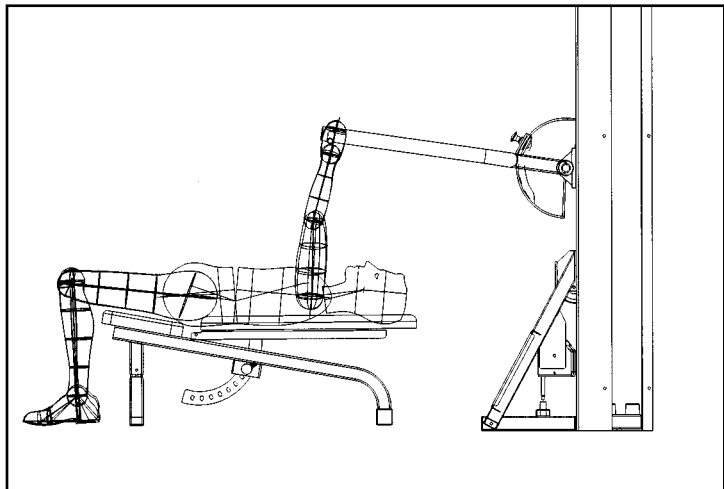

### **Incline Bench Press**

(BENCH POSITIONS 6 - 10)

Emphasis: Pectoralis Major,  
Anterior Deltoid, Triceps

1. Slide the adjustable bench into the pressing station and align the handle set midchest.
2. Adjust the pressing arm to the desired range of motion. The upper arm should not be below parallel with the floor.
3. Position feet firmly on the floor for increased stability.
4. Inhale as you lower the weight and exhale as you press upward.

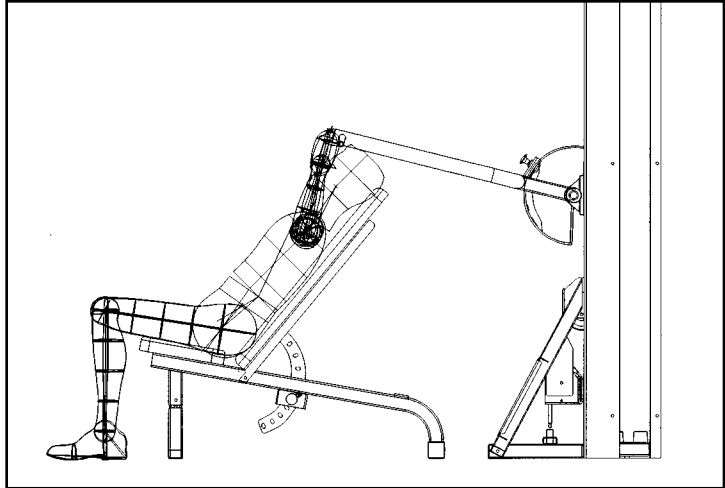

### **Military Press**

(BENCH POSITION 2)

Emphasis: Anterior Deltoid, Triceps

1. Slide the adjustable bench into the pressing station. Face machine and align handles at shoulder height.
2. Adjust the pressing arm to the desired range of motion. The upper arm should not be below parallel with the floor.
3. Pinch shoulder blades down and back to stabilize the spine and maximize effectiveness.
4. Inhale as you lower the weight and exhale as you pull upward.

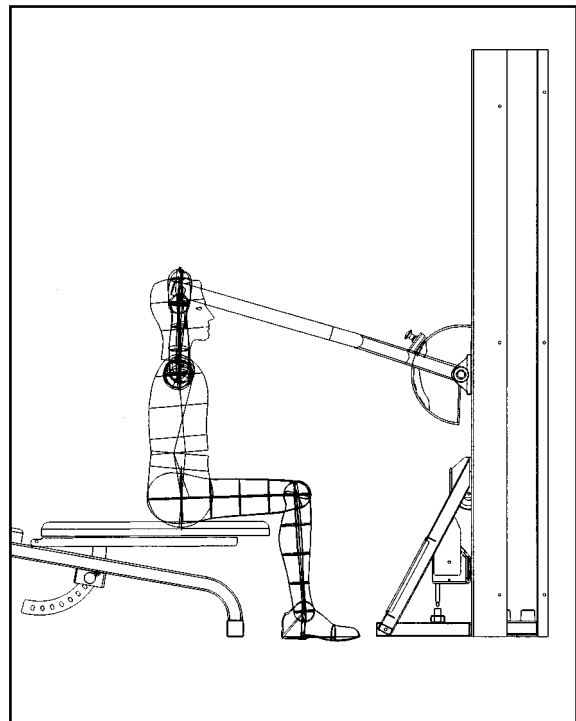

### Chest Press

Emphasis: Pectoralis Major

1. Adjust seat back to desired range of motion and handle height to midchest.
2. Grip the handles and position elbows out to the sides, level with handles.
3. Pinch shoulder blades back and together.
4. Leave a slight bend in your arms while tightening your chest and slowly moving the handles toward midline until they meet.
5. Return to starting position in a slow, controlled manner without resting.

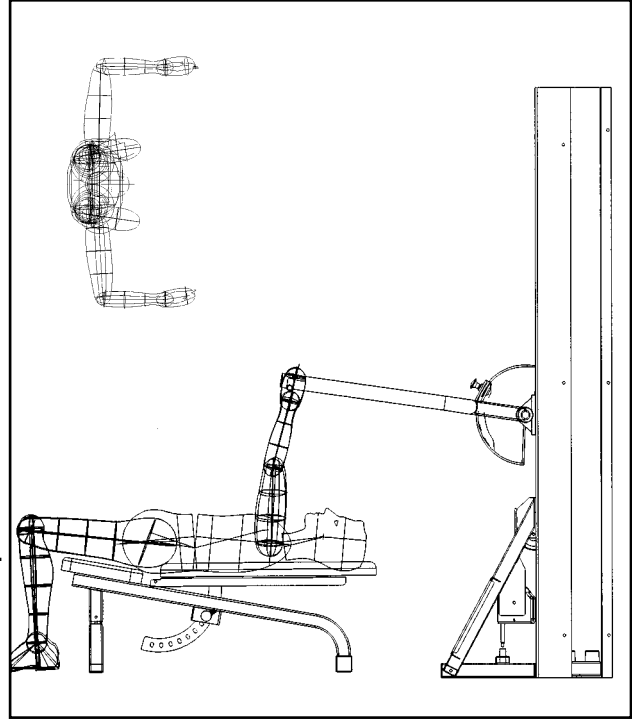

### Chest Fly

Emphasis: Pectoralis Major

1. Adjust seat back to desired range of motion and handle height to midchest.
2. Grip the handles and position elbows out to the sides, level with handles.
3. Pinch shoulder blades back and together.
4. Leave a slight bend in your arms while tightening your chest and slowly moving the handles toward midline until they meet.
5. Return to starting position in a slow, controlled manner without resting.

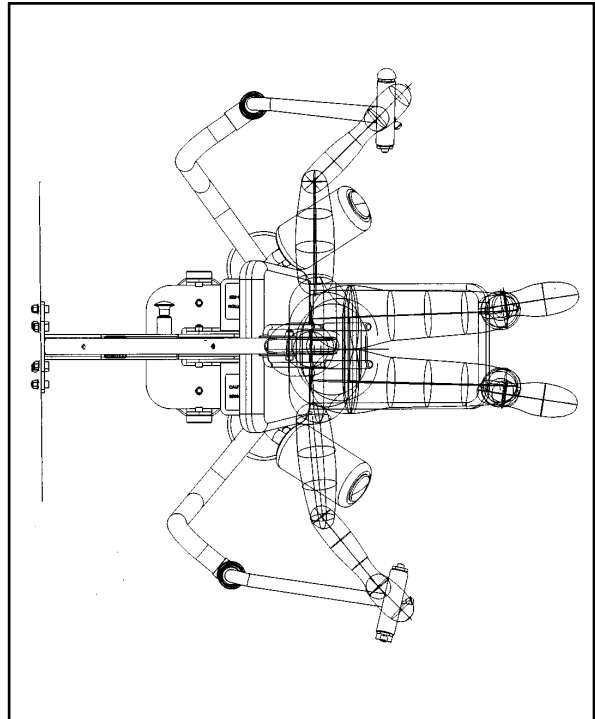

### **Tricep Pressdown**

Emphasis: Triceps

1. Attach the rotating curl bar to the lat pulldown boom.
2. Face machine with legs straddling the seat, grip the bar with palms facing down.
3. Start exercise with bar close to your chest and elbows at your side.
4. Tighten triceps and extend arms as far as possible without moving either elbows or shoulders.
5. Inhale while returning to the start position without resting or changing the shoulder/arm position.

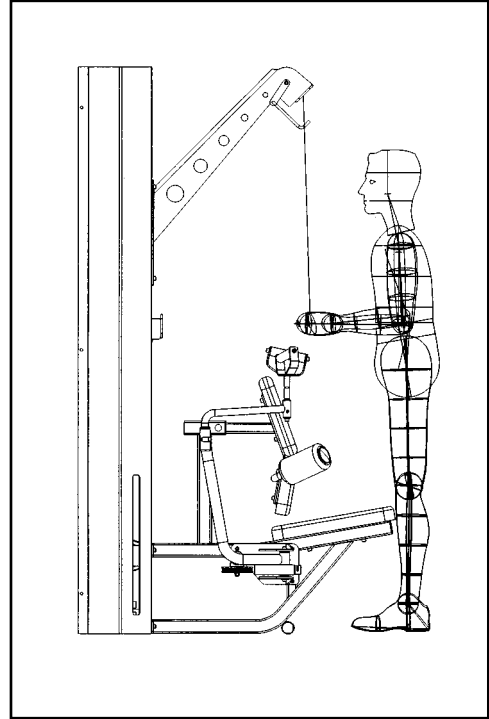

### **Overhead Tricep Extension**

Emphasis: Triceps

1. Slide adjustable bench into pressing station and set to position 5.
2. Attach soft crossover handles to midpulley.
3. From a seated position, reach back and grasp handles. Arms should be vertical while the palms remain facing upward.
4. Tighten triceps and extend arm as far as possible without moving either elbows or shoulders.
5. Inhale while returning to the start position without resting or changing the shoulder/arm position.

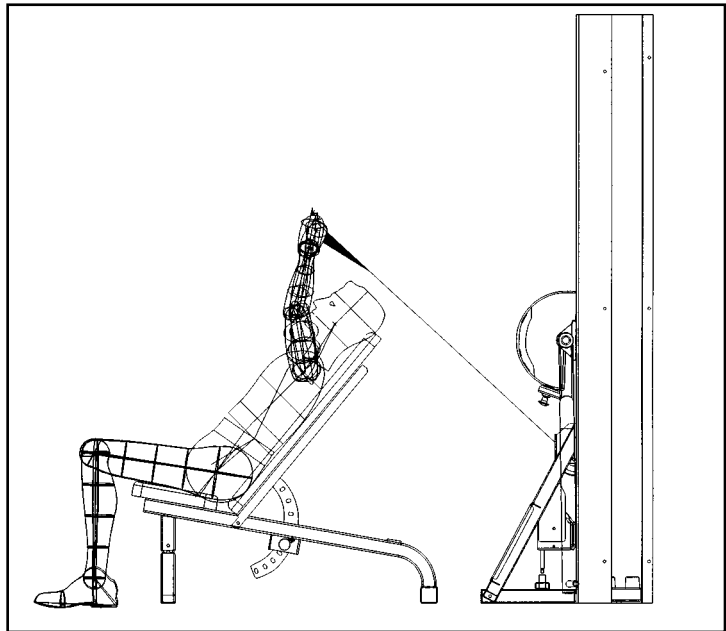

### **Standing Arm Curl**

Emphasis: Biceps

1. Attach rotating curl bar to swivel low-pulley. Face the machine, and grip the bar with palms up.
2. Stand erect, keep arms close to sides, exhale while tightening biceps and flexing elbows as far as possible without raising shoulders.
3. Inhale as you lower the weight.

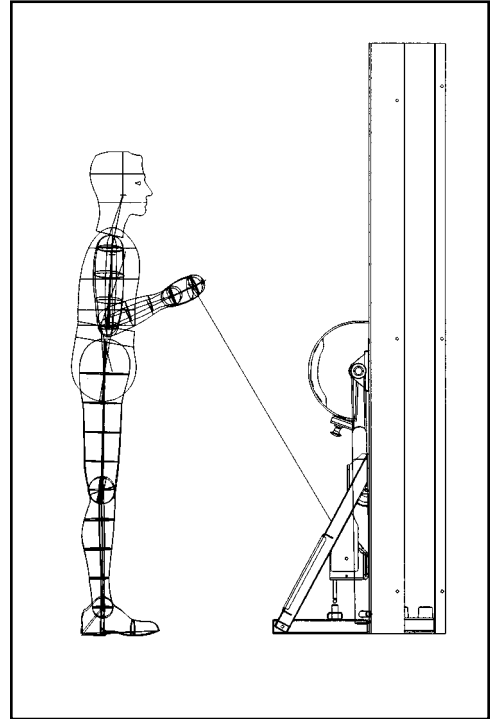

### **Hammer Curl**

Emphasis: Brachioradialis, Biceps

1. Attach soft crossover handles to swivel low-pulley. Face the machine and grasp the handles with palms facing upward.
2. Stand erect and while keeping the arms close to the sides tighten the biceps/forearms and flex the elbows as far as possible without raising the shoulders.
3. Inhale as you lower the weight.

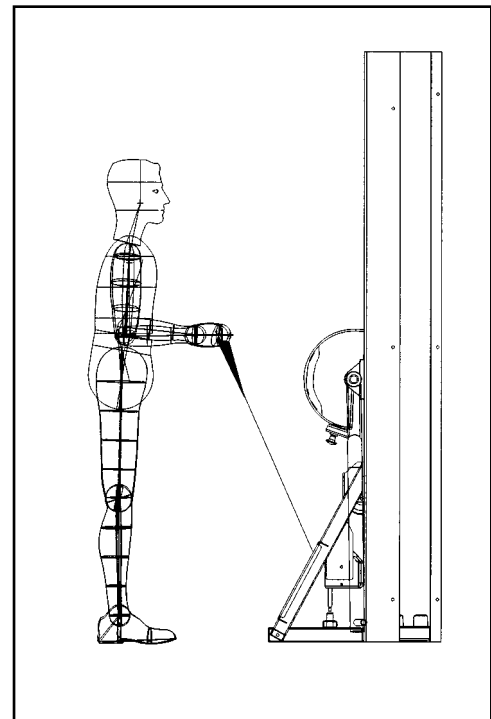

### **Wrist Curl**

Emphasis: Forearm Flexors

1. Lower the pressing station arm into bottom position and attach rotating curl handle to swivel low-pulley.
2. Slide the adjustable bench into pressing station and set to position 2, allowing feet to rest on platform. Sit facing the machine and grasp handle with palms facing up and forearms resting on knees.
3. Tighten forearms and curl handle up and in, moving as far as possible without additional arm or shoulder motion.
4. Inhale as you lower the weight.

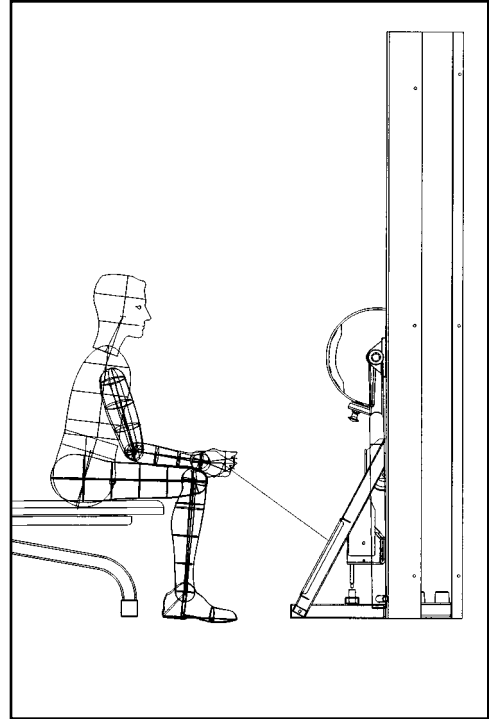

### **Abdominal Crunch**

Emphasis: Rectus Abdominus

1. Adjust seat back to desired starting position.
2. Position back firmly against back pads.
3. Position handles over shoulders and securely against chest.
4. Crunch forward directing ribs down toward pelvis with smooth controlled movements.
5. Return to the starting position and repeat without resting.

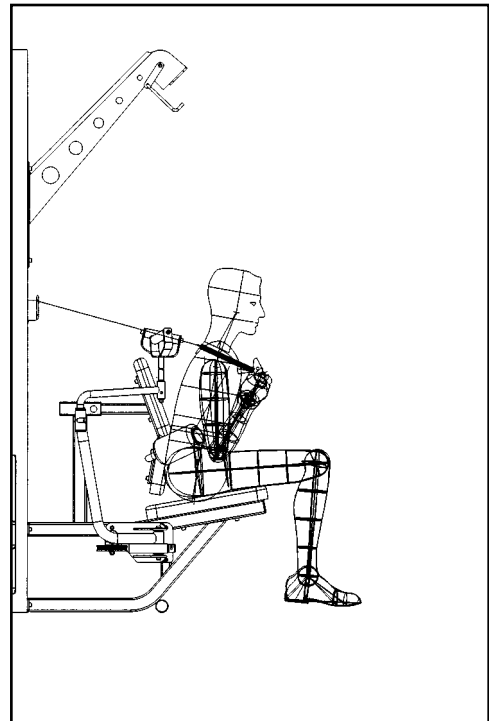

## Seated Leg Press

**NOTE:** The appropriate starting position will allow your feet to be securely located on foot plates, legs to be placed at approximately 90 degrees and your back squarely positioned against back pad.

**NOTE:** Maintain proper back positioning during exercise to reduce chance of back injury.

Emphasis: Quadriceps, Glutes, Hamstrings.

1. Select appropriate resistance.
2. Adjust seat mechanism to desired starting position.
3. Locate feet securely on foot plates and position yourself squarely in seat.
4. Lift/lower resistance with smooth controlled movements without resting.
5. Do not hyperextend (lock) knees during movement.

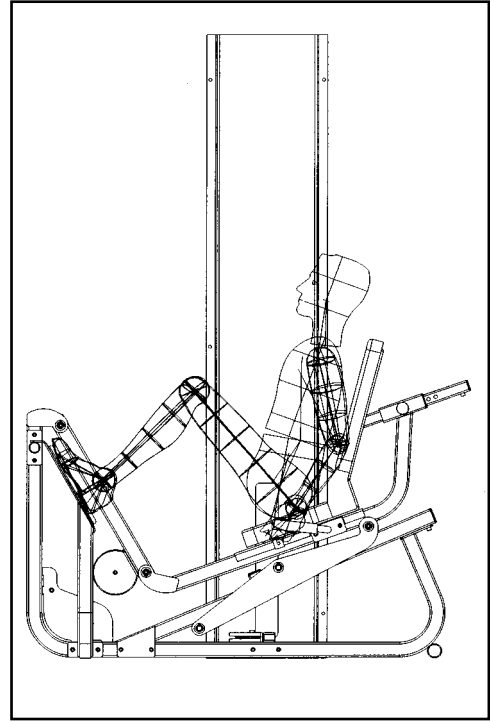

### Uni-Lateral Seated Row

Emphasis: Latissimus Dorsi,  
Teres Major, Trapezius,  
Brachioradialis

1. Lower the pressing station arm into the bottom position and attach a soft crossover handle to midpulley.
2. Slide the adjustable bench into the pressing station and set on position 1, allowing easy access to foot rests.
3. Place feet on rests and keep back straight. Bend forward at the hips and grasp handle. Maintaining an upright position, pull toward side of body.
4. Pinch shoulder blades back to maximize stability and effectiveness.

**NOTE:** This exercise offers a unique opportunity in requiring the exerciser to stabilize against side-bending for improved muscular function.

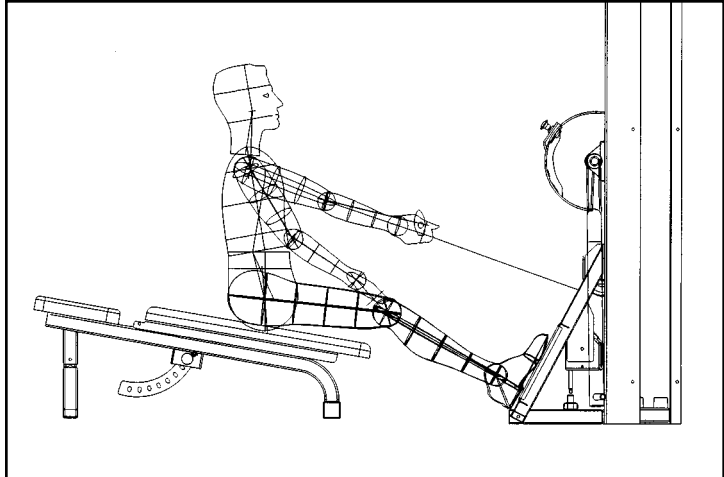

### Seated Calf Raise

Emphasis: Gastrocnemius, Soleus

*The appropriate position will allow your feet to be securely located on the lower third of the foot plates, knees slightly bent and back squarely positioned against back pad.*

1. Adjust seat mechanism to a position which requires you to press about 4" in order to position yourself for the exercise.
2. Locate feet securely on the lower third of the foot plates, and position yourself squarely in the rest.
3. Press the weight up about 4" while allowing a slight bend in the knees for safety.
4. Maintaining a slight bend in knees, lower heels slightly past the plane of the foot plates then press heels back-up with a smooth controlled motion.

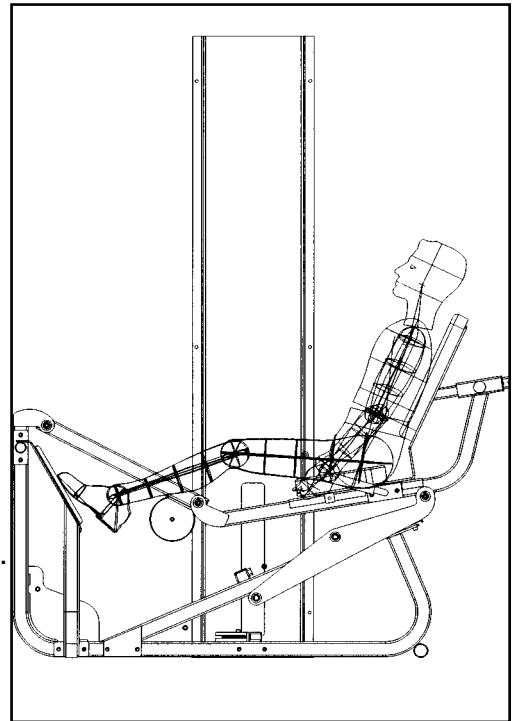

## 5 - Customer Service

### Ordering Parts

When contacting Customer Service, call 888-GO CYBEX (888-462-9239) or 508-533-4300 or fax 508-533-5183 during the hours of 8:00 a.m. - 6:00 p.m. (Eastern Standard Time) Monday through Friday. Please specify if you need inside sales support or technical support.

Information can also be found on the web at [www.eCybex.com](http://www.eCybex.com) or by email at [techhelp@cybexintl.com](mailto:techhelp@cybexintl.com).

Having the following information ready when calling will assist our Cybex representatives in serving you:

- **Unit Serial Number**
- **Product Name**

*The unit serial number and product name can be found on the serial number decal. See Chapter 8 for exact location of serial number decal.*

- **Part Description**
- **Part Number**

*Part descriptions and part numbers are located in Chapter 8 of this manual.*

- **Upholstery Color**

*When ordering cushions or wear covers please be ready to provide the exact upholstery color required.*

- **Shipping Address**
- **Contact Name**

*In addition to your shipping address and contact name, your account number is helpful but not required.*

## **LIMITED WARRANTY FOR ALL CYBEX COMMERCIAL STRENGTH PRODUCTS**

**NOTE: Save this document for your records.** This warranty includes all Cybex commercial Strength products, including: CYBEX "EAGLE", "FREE WEIGHT", "FUNCTIONAL TRAINER", "MODULAR", "MULTI-GYM", "PLATE LOADED", "VR" and "VR2" Products.

**WHO IS COVERED:** The original buyer purchasing the product from Cybex or its designee. Buyer includes any person receiving the product in an unused condition as a gift from the original buyer. The terms "you" and "your" are used in this Limited Warranty to refer to the original buyer and any person receiving the product as a gift from the original buyer. The terms "we," "us" and "our" are used in this Limited Warranty to refer to Cybex International, Inc. **This warranty covers all products sold under the Cybex "Eagle", "Free Weight", "Functional Trainer", "Modular", "Multi-Gym", "Plate Loaded", "VR" and "VR2" names and used in the continental United States. Products sold or moved outside the borders of the continental United States of America are subject to the terms provided by the local distributor, and are not covered under this warranty.**

**WHAT IS COVERED:** Except as otherwise stated in this Limited Warranty, we will repair or correct any product or part defect which we determine is related to materials or workmanship and is not due to normal wear and tear occurring during the stated WARRANTY PERIOD.

**WHAT IS NOT COVERED:** Product requires normal maintenance including, but not limited to, regular inspection and wear component replacement. We do not warrant damage caused by the lack of normal maintenance repairs such as those detailed within the Owner's Manual. We do not warrant any causes beyond our control. Corrosion, oxidation or deterioration caused by product location, exposure or environment, or conditions caused by unsuitable finishes, cleaners, or lubricants are not covered. Damage or breakage caused by unauthorized service, installation, alteration, modification, assembly or disassembly, negligence, or conditions of use which are unintended for the product are not warranted. This warranty does not cover cosmetic or surface corrosion resulting from chips or scratches in the paint. Extra expenses including, but not limited to, loss of machine use and inconvenience are not covered. Due to varying conditions under which the product is used, we offer no warranties, express or implied, as to the length of service. We do not warrant any products that have not been paid for, or in the event that we have offered a payment plan, products owned by buyers who are in arrears on a payment plan. If you are a non-consumer buyer, we only warrant products purchased directly from us or from one of our authorized dealers in that dealer's authorized territory. **THIS WARRANTY DOES NOT COVER UNINTENDED USE.** See "INTENDED USE" below.

**INTENDED USE:** This warranty covers only defects that arise in the ordinary, intended use of the product. Products sold under the Cybex "Eagle", "Free Weight", "Functional Trainer", "Modular", "Multi-Gym", "Plate Loaded", "VR" and "VR2" names are intended for commercial use, including use in health clubs and similar facilities.

**WARRANTY PERIOD:** The warranty period begins on the date the product was delivered to you. The warranty period for the structural frame expires after ten (10) years. The warranty period for rotary bearings, guide rods, pulleys, weight stacks, bushings, linear bearings, bars, handles, and all other parts not listed herein expires after two (2) years. The warranty period for cables and belts expires after one (1) year. The warranty period for upholstery and handgrips expires after one hundred twenty (120) days.

**WHO WILL PAY LABOR AND TRANSPORTATION COSTS:** If we determine, during the first year of the warranty period, that the product or any covered part must be shipped to the manufacturing facility for repair or service, all warranty repairs, including transportation costs and labor, will be made at NO CHARGE to you; thereafter, you will be responsible for labor and transportation costs for repair or service.

**WHAT YOU MUST DO TO OBTAIN WARRANTY COVERAGE:** Retain proof of purchase. All warranty repairs and corrections require proof of purchase. To obtain coverage, please contact Cybex Customer Service within seven (7) days after discovery of the defect and follow the directions provided to you by your Cybex Service Representative.

**WHAT WE WILL DO TO CORRECT COVERED REPAIRS:** Authorized repairs or corrections will be performed using new or remanufactured parts shipped to you, or at our discretion, replacement of the product. Any replacement parts provided to you are warranted for the remaining portion of the original WARRANTY PERIOD.

**MODIFICATIONS TO WARRANTY ARE NOT AUTHORIZED:** No one is authorized to modify, change, transfer or extend in any way the terms of this Limited Warranty.

**THINGS TO KNOW ABOUT OBTAINING PRODUCT ACCESSORIES, PARTS AND REPAIR**

**SERVICE:** To secure repair service under this warranty, please contact Cybex Customer Service at (508) 533-4300, Monday - Friday from 8:00 - 6:00 p.m. Eastern time. To expedite service, please have your product serial number available when calling. Your customer service technician will assist you with any shipping or repair requirements deemed necessary to obtain repair or correction. A Return Authorization Number (RA#) is required when returning a product or part if the item is to be covered under warranty. We are not responsible for products or parts shipped to our facility without a RA#. All returns shall be accompanied by a proof of purchase to ensure warranty coverage. We may require the product or part be returned for inspection prior to making a warranty coverage decision.

You may also contact us by writing to: Cybex International, Inc., Attn: Customer Service Department, 10 Trotter Drive, Medway, MA, 02053.

**DISCLAIMER OF WARRANTIES AND LIMITATION OF REMEDIES:** It is impossible to eliminate all risks inherently associated with use of this product. Personal injury or other unintended consequences may result because of factors beyond our control. WE MAKE NO OTHER WARRANTIES OF ANY KIND, EXPRESS OR IMPLIED, OTHER THAN THOSE EXPRESSLY SET FORTH WITHIN THIS DOCUMENT. ALL WARRANTIES OTHER THAN THE WARRANTIES EXPRESSLY PROVIDED HEREIN ARE SPECIFICALLY EXCLUDED. IN THE CASE OF NON-CONSUMER BUYERS, ALL IMPLIED WARRANTIES OF MERCHANTABILITY AND FITNESS FOR A PARTICULAR PURPOSE ARE HEREBY DISCLAIMED.

IN THE CASE OF A CONSUMER BUYER, THE DURATION OF ALL IMPLIED WARRANTIES OF MERCHANTABILITY OR FITNESS FOR A PARTICULAR PURPOSE IS LIMITED TO THE DURATION OF THE EXPRESS WARRANTIES PROVIDED WITHIN THIS DOCUMENT.

WE WILL NOT BE LIABLE FOR ANY DIRECT OR INDIRECT, CONSEQUENTIAL OR INCIDENTAL DAMAGES, LOSSES OR EXPENSES, INCLUDING BUT NOT LIMITED TO COMMERCIAL LOSSES, BUSINESS INTERRUPTION, OR DAMAGE TO PROPERTY OTHER THAN THE PRODUCT OR PRODUCTS TO WHICH THIS LIMITED WARRANTY APPLIES.

**EFFECT OF STATE LAWS:** Some States do not allow limitations on how long an implied warranty lasts, so the above limitation may not apply to you. Some States do not allow the exclusion or limitation of incidental or consequential damages, so the above limitation or exclusion may not apply to you. This warranty gives you specific legal rights, and you may also have other rights which vary from State to State.

**ALTERNATIVE DISPUTE RESOLUTION FOR NON-CONSUMER BUYERS:** WE RESERVE THE RIGHT TO MANDATE ALTERNATIVE DISPUTE RESOLUTION TO SETTLE ANY OR ALL CLAIMS RESULTING FROM THIS SALES TRANSACTION. ALTERNATIVE DISPUTE RESOLUTION PROCEEDINGS WILL BE CONDUCTED IN THE STATE OF MASSACHUSETTS ACCORDING TO THE COMMERCIAL RULES OF THE AMERICAN ARBITRATION ASSOCIATION.

## **Delivery Inspection**

Upon arrival, it is important that you thoroughly inspect all of the equipment for damage.

If you discover damage, point it out to the truck driver and request that the driver make a record of the damage on the receiving report. Be sure to obtain a copy of the receiving report for your files.

**Apparent Damage** - Any damage seen with a visual check must be noted on the freight bill and signed by the carrier's agent. Failure to do so will result in the carrier's refusal to honor your damage claim. The carrier will provide you with the required forms for filing such claims.

**Concealed Damage** - Damage not seen with a visual check upon receipt of a shipment but noticed later must be reported to the carrier as soon as possible. Upon discovery of the damage, a written or phone request to the carrier asking them to perform an inspection of the materials must be made within ten days of the date of delivery. Keep all shipping containers and packing materials - they will be needed as part of the inspection process. The carrier will provide you with an inspection report and the necessary forms for filing a concealed damage claim. Concealed damage is the carrier's responsibility.

- Contact Cybex Technical Support if you received damaged equipment and provide them with the information on the report regarding your damaged equipment.
- Contact Cybex Inside Sales if you did not receive the appropriate equipment and provide them with the information regarding your order.

You may call Cybex at 888-462-9239 (888-GO CYBEX) and specify if you are calling for a Technical Support Representative or an Inside Sales Representative.

## **Installation**

See Chapter 6 for proper installation. Allow the appropriate operating space between machines. It is the responsibility of the purchaser to determine the appropriate operating space for customer safety and convenience. Do not crowd the exercise area.

### **Safety**

Use extra caution when assembling and installing equipment, particularly when lifting or moving heavy objects (such as installing weight stacks) and when using power tools.

## Returning Goods

When agreed to by Cybex, the buyer may return products with a Return Material Authorization Number (RMA).

The RMA number can be obtained through the Cybex Customer Service department. **Under no circumstances will defective parts or equipment be accepted by Cybex without proper the proper RMA number and prepayment of all postage or freight charges.**

Please use the following steps when obtaining an RMA number.

1. Call the Customer Service Hotline at 888-GO-CYBEX (888-462-9239) for the return of any item that is defective.
2. Provide the technician with a detailed description of the problem you are having or the defect in the item you wish to return.
3. Provide the model and serial number of your Cybex product. The serial number location can be found in Chapter 8.
4. If your situation cannot be resolved over the phone, the technician will request that you return the defective part(s) to Cybex for repair or replacement. You will then be given an RMA number. Write the RMA number on the outside of the package that contains the item(s) to be returned. Along with the parts, please include a description of the problem, the serial number of the unit, your facility name address and phone number as well as a contact name.
5. Forward the package to Cybex, prepaid for shipping charges.

**NOTE:** *Merchandise returned without an RMA number on the outside of the package or shipments sent C.O.D. will not be accepted by the Cybex receiving department.*

***This page intentionally left blank***

# 6 - Assembly

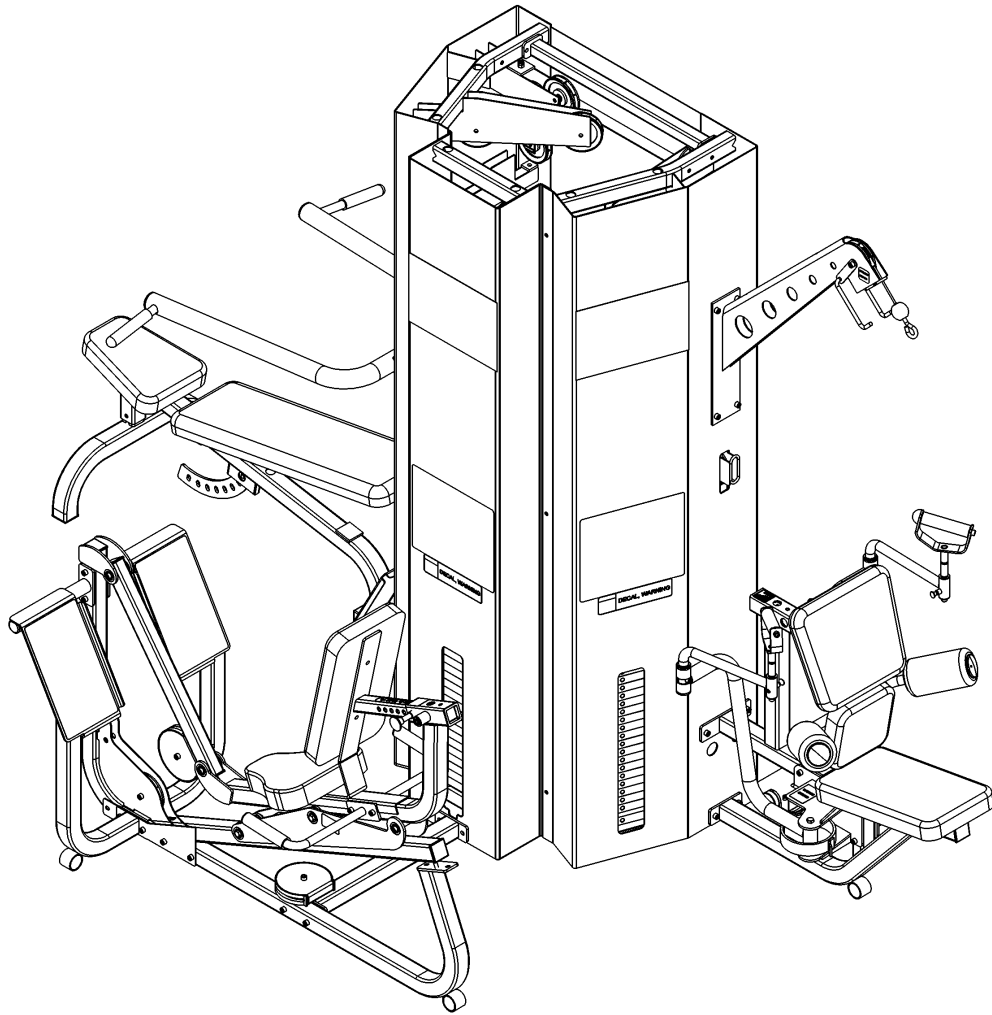

***! WARNING: Use extreme caution when assembling the MG 500, especially when working on the inside of the main frame assembly. Failure to do so could result in injury.***

### **Tools Required**

- 7/32" Allen wrench
- 5/16" Allen wrench
- 9/16" Socket/wrench
- External snap ring pliers
- Rubber mallet
- Step ladder
- Automotive engine oil
- Utility knife

### **Unpacking Main Frame Assembly**

**NOTE:** Two or three people are required to assemble the MG 500.

**1. Read and understand all instructions thoroughly before assembling the MG 500.**

**NOTE:** Each step number in the assembly instructions tells you what you will be doing. The lettered steps following each step number describes the procedure required. Do not continue with step 2 until you have carefully read all of the assembly instructions.

**2. Verify you have received the appropriate configuration (see steps 2A and 2B).**

- A.** If you ordered the Leg Extension/Leg Curl configuration (8600-001), verify you have the following: Leg Extension/Leg Curl box, Pressing Station box, Fly Station box, three weight stacks (17 plates each) and the main frame.
- B.** If you ordered the Leg Press configuration (8602-001), verify you have the following: Leg Press box, Pressing Station Box, Fly Station box, three weight stacks (17 plates each) and the Main Frame.

**3. Unpacking main frame assembly (see steps 3A - 3D and Figure 1, located on the next page).**

- A.** Carefully place MG 500 near area of installation. A minimum amount of area required is 164" L x 110" W.
- B.** Using a 5/16" Allen wrench, remove the 12 SHCS .375-16 x .625 screws (six for each panel) securing the two back panels. See Figure 1.
- C.** Carefully remove the two panels and set them aside (along with the 12 screws).
- D.** Remove the main frame hardware box and three cushion boxes located on the inside of the main frame assembly. Set the boxes aside.

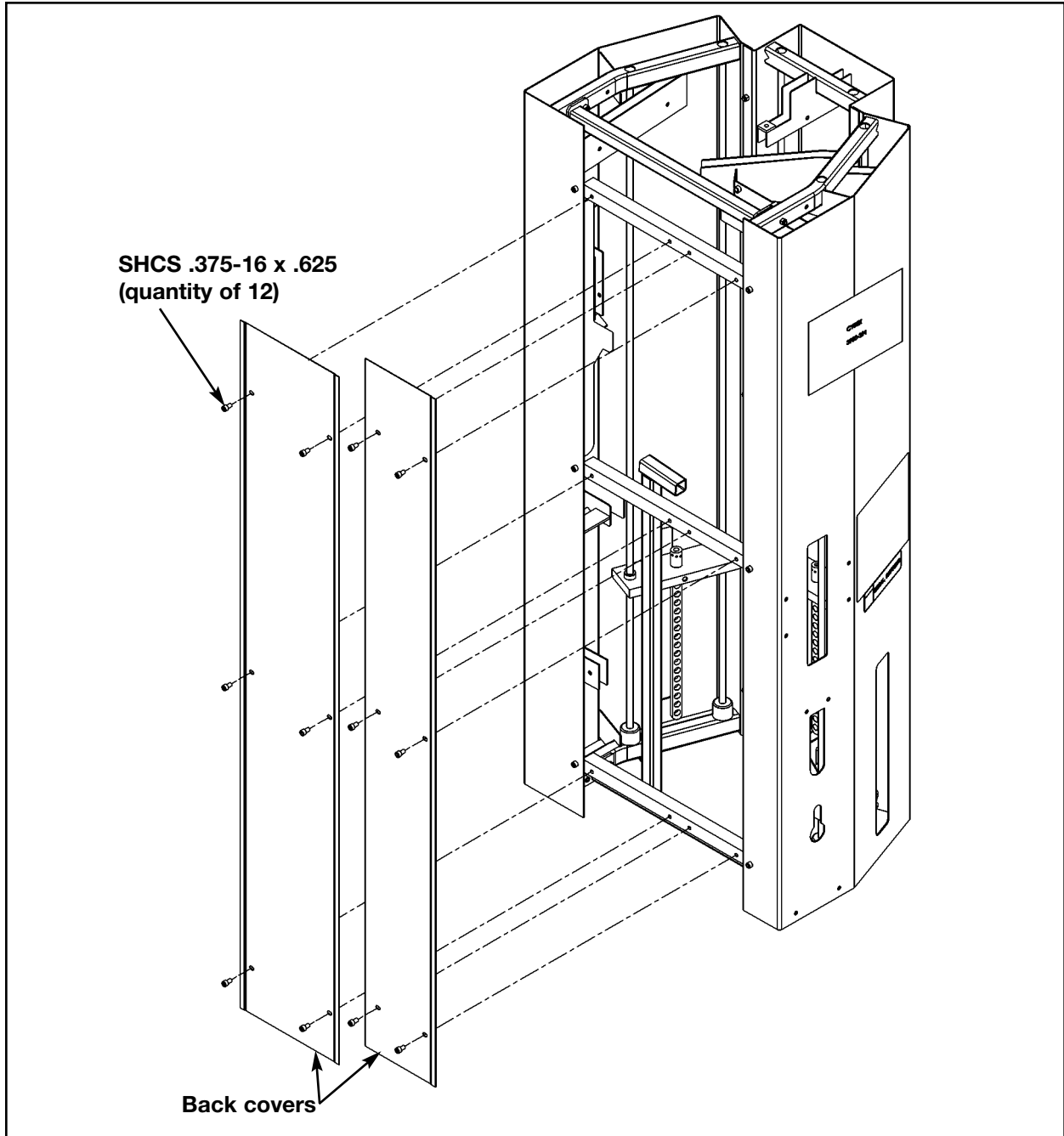

Figure 1

4. Removing main frame assembly from pallet (see steps 4A - 4F).

A. Remove the shipping brackets securing main frame to the pallet. See Figure 1 located on the previous page.

**! WARNING: The main frame assembly weighs approximately 600 pounds and will be difficult to remove from the pallet. A minimum of three people are required to remove main frame assembly from the shipping pallet. Use extreme caution Failure to do so could result in injury.**

B. Determine the exact location for the MG 500 based upon overall size.

C. Carefully move and tip main frame assembly so that the Fly Station end is leaning off the pallet.

D. Carefully raise main frame assembly high enough so that a third person can remove the pallet.

E. Carefully lower and position main frame assembly so that it is in the exact area where the MG 500 will be used.

F. Remove all three braces as shown in Figure 2. Set aside braces and hardware. The braces will be re-installed at the end of the assembly procedure.

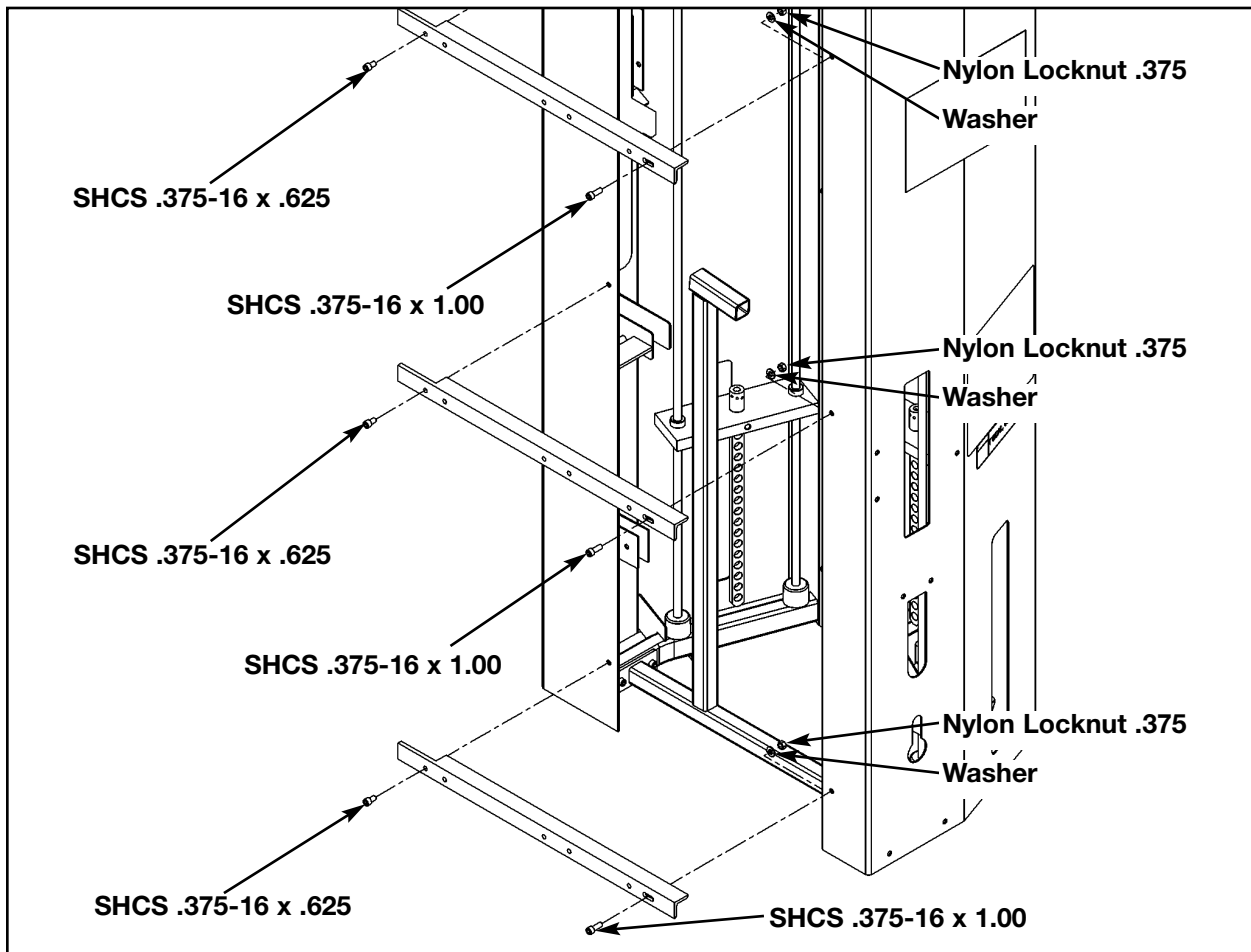

**5. Verify contents of the two main frame hardware packs** (see steps 5A, 5B, Figures 3 and 4).

**A.** Remove the two hardware packs from the main frame hardware box.

**B.** Verify contents of both hardware packs. These parts are used on the inside of the MG 500 (such as for routing cables). See Figures 3 and 4.

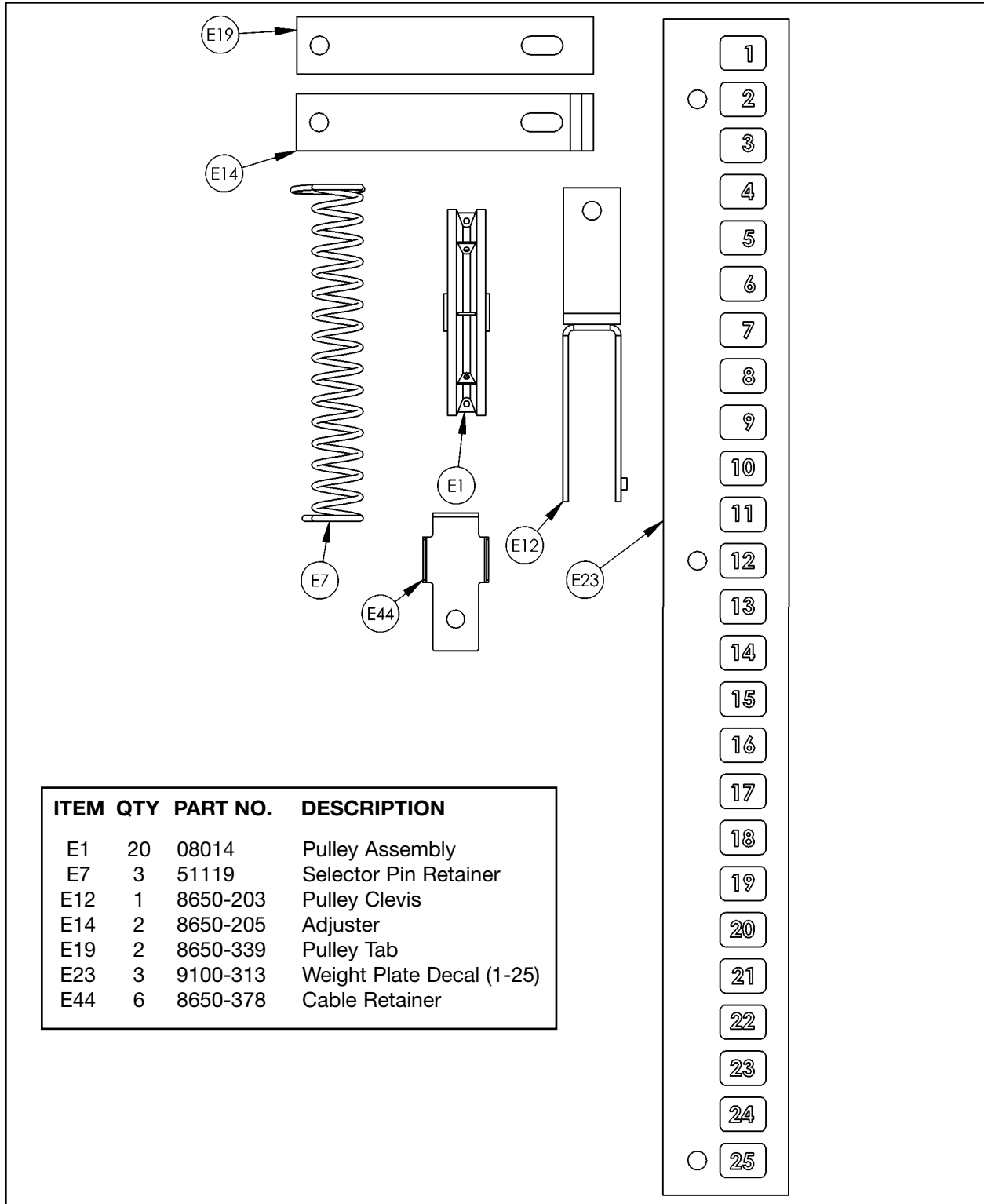
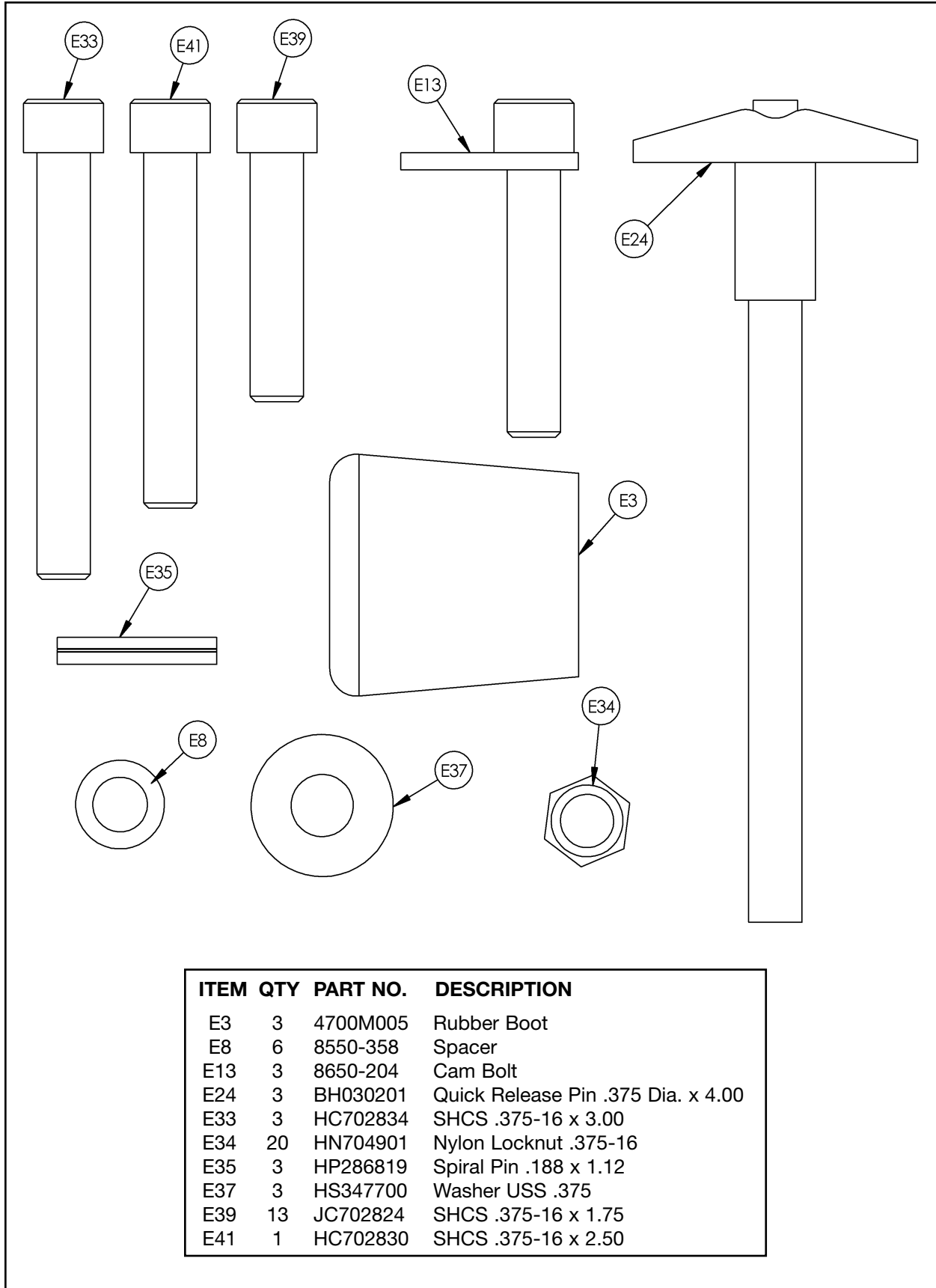

Figure 3



| ITEM | QTY | PART NO. | DESCRIPTION                        |
|------|-----|----------|------------------------------------|
| E3   | 3   | 4700M005 | Rubber Boot                        |
| E8   | 6   | 8550-358 | Spacer                             |
| E13  | 3   | 8650-204 | Cam Bolt                           |
| E24  | 3   | BH030201 | Quick Release Pin .375 Dia. x 4.00 |
| E33  | 3   | HC702834 | SHCS .375-16 x 3.00                |
| E34  | 20  | HN704901 | Nylon Locknut .375-16              |
| E35  | 3   | HP286819 | Spiral Pin .188 x 1.12             |
| E37  | 3   | HS347700 | Washer USS .375                    |
| E39  | 13  | JC702824 | SHCS .375-16 x 1.75                |
| E41  | 1   | HC702830 | SHCS .375-16 x 2.50                |

## Installing Weight Stacks

**! WARNING:** Use extreme caution when installing the weight stacks, especially when working on the inside of the main frame assembly. Failure to do so could result in injury.

**NOTE:** Two people will be required to perform this procedure.

**1. Install Pressing Station weight stack** (see steps 1A - 1S, Figures 1 and 2).

**A.** Remove the four SHCS and nylon locknuts securing the pulley bracket. See Figure 1.

**B.** Slide bracket downward and remove.

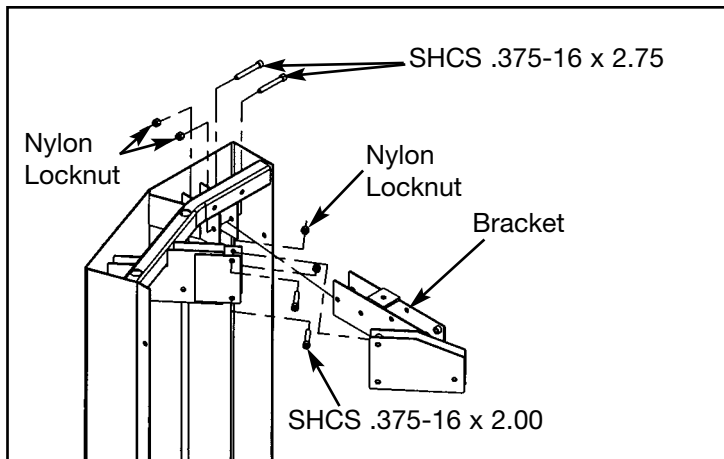

Figure 1

**C.** Using an external snap ring pliers, slide the lower snap ring down about two inches from the top part of the guide rod (this will provide access to the upper ring). See Figure 2.

**NOTE:** A step ladder may be helpful when removing snap rings.

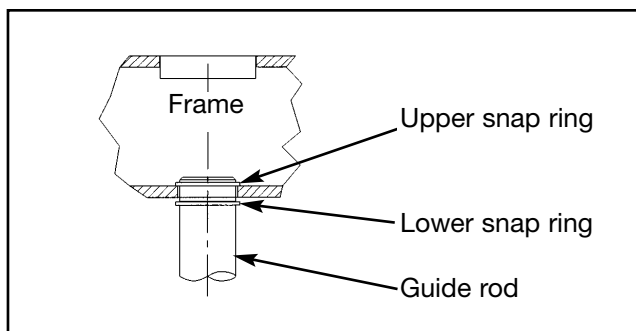

Figure 2

**D.** Repeat step 1C for the other guide rod.

- E. Raise one of the guide rods high enough to expose the upper snap ring. Using an external snap ring pliers, remove upper snap ring and then carefully lower guide rod.
- F. Repeat step E for the other guide rod.
- G. Remove lower snap ring on each guide rod.
- H. Lean each guide rod outward.
- I. Using a utility knife, cut the shipping tie strap securing the top weight and carefully remove top weight.
- J. Wipe both guide rods clean over entire length. Lubricate with light coating of medium weight automotive engine oil.
- K. With an assistant, carefully install each weight plate one at a time. **NOTE:** *Install weight plates in reverse order as removed in step 7M. NOTE: When installing weight plates, position plates so wide edges of bushings face upward and narrow edges of bushings face downward. See Figures 3A and 3B.*

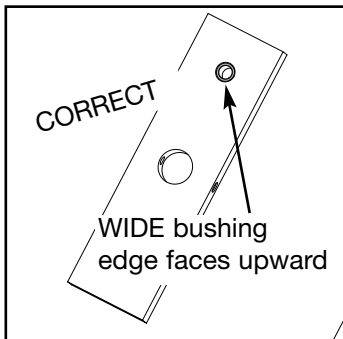

Figure 3A

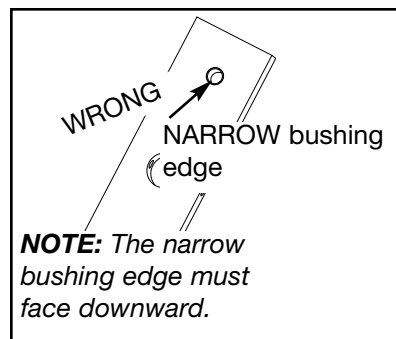

Figure 3B

- L. Slide top weight onto guide rods.
- M. On each guide rod, place lower snap rings at least two inches below top end of guide rod.
- N. On one of the guide rods, install the upper snap ring. Lower guide rod and secure lower snap ring.
- O. Repeat step N for other guide rod.
- P. Install pulley bracket (removed in steps 1A and 1B). See Figure 1.
- Q. Carefully install weight detent pin onto spiral cord.
- R. Place ring end of spiral cord over stem of top weight.
- S. Place rubber cap over stem of top weight so that rubber cap is loose and easy to remove. The rubber cap will be removed later and placed on the weight stack cable.

2. Install optional station weight stack (see steps 2A - 2Q and Figure 4).

**! WARNING:** Use extreme caution when installing the weight stacks, especially when working on the inside of the main frame assembly. Failure to do so could result in injury.

**NOTE:** Two people will be required to perform this procedure.

- A. Using an external snap ring pliers, slide the lower snap ring down about two inches from the top part of the guide rod (this will provide access to the upper ring). See Figure 4.

**NOTE:** A step ladder may be helpful when removing snap rings.

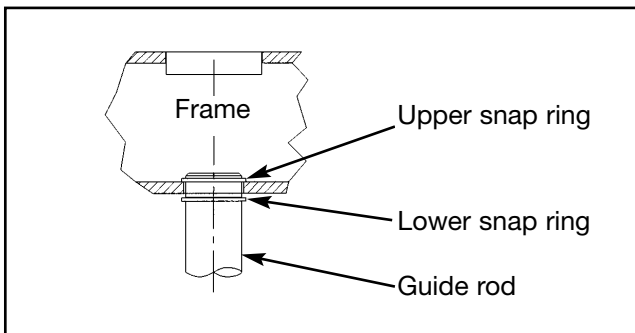

Figure 4

- B. Repeat step A for other guide rod.
- C. Raise one of the guide rods high enough to expose the upper snap ring. Using an external snap ring pliers, remove upper snap ring and then carefully lower guide rod.
- D. Repeat step C for the other guide rod.
- E. Remove lower snap ring on each guide rod.
- F. Lean each guide rod outward.
- G. Using a utility knife, cut the shipping tie strap securing the top weight and carefully remove top weight.
- H. Wipe both guide rods clean over entire length. Lubricate with light coating of medium weight automotive engine oil.
- I. With an assistant, carefully install each weight plate one at a time. **NOTE:** See Figure 3A for proper positioning of weight plates.

- J. Slide top weight onto guide rods.
- K. On each guide rod, place lower snap rings at least two inches below top end of guide rod.
- L. On one of the guide rods, install the upper snap ring. Lower guide rod and secure lower snap ring.
- M. Repeat step M for other guide rod.
- O. Carefully install weight detent pin onto spiral cord.
- P. Place ring end of spiral cord over stem of top weight.
- Q. Place rubber cap over stem of top weight so that rubber cap is loose and easy to remove. The rubber cap will be removed later and placed on the weight stack cable.

**3. Install optional station weight stack - Leg Press Station only** (see step 3A).

- A. Repeat steps 2A - 2Q.

**4. Install optional station weight stack - Leg Extension/Leg Curl Station only** (see steps 4A - 4C and Figure 5).

- A. Repeat steps 2A - 2I. **NOTE:** Do not install top weight plate or second weight.

- B. Locate spring pin 10 mm x 90 mm from the Leg Extension/Leg Curl hardware pack (located in the Leg Extension/Leg Curl (frame) carton). Slide top weight plate onto second plate and carefully pound the spring pin into the second weight plate hole, securing second plate to the top weight plate. See Figure 5. **NOTE:** Insert pin so that it is flush with the weight plate.

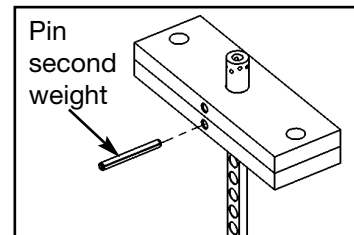

Figure 5

- C. Repeat steps 2J - 2Q.

**5. Install weight plate decals** (see steps 5A - 5F).

- A. Locate the weight stack number decals (quantity of three).
- B. Carefully peel the backing off the decal. Align holes in decal with holes with appropriate holes in weight stack. **NOTE:** Do not allow adhesive to touch weight stack at this time.
- C. Insert a guide rod through each hole of the template. **NOTE:** A guide rod can be anything that fits through the weight stack hole, such as a weight stack selector pin.
- D. Carefully align and rub decal onto weight plates.
- E. Carefully remove front side, leaving numbers adhering to weight plates.
- F. Repeat steps 5A - 5E to install all weight plate decals to all three weight stacks.

**Fly Station Diagram**

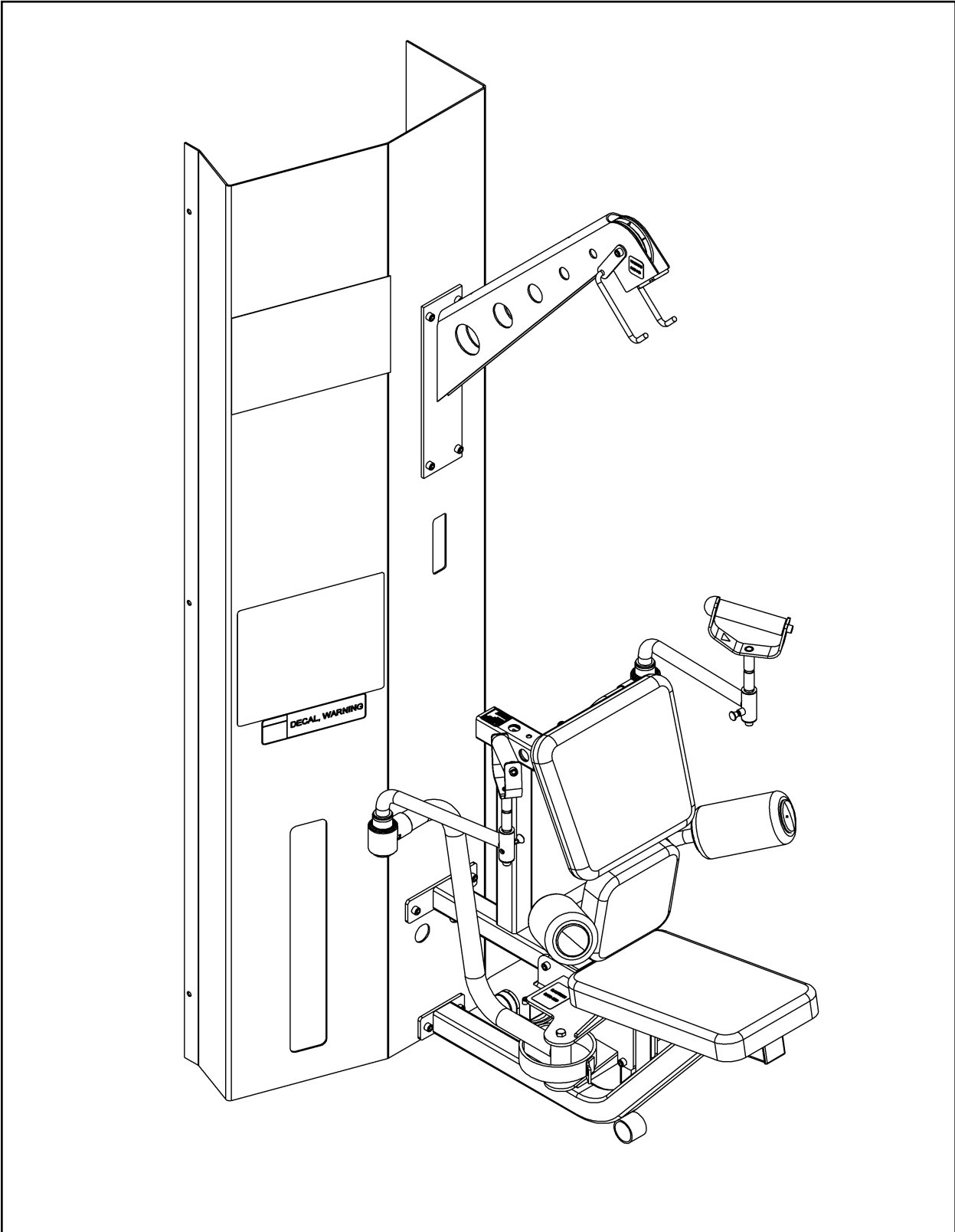

**Fly Station Assembly**

- 1. Verify contents of the Fly Station boxes** (see steps 1A - 1C and Figures 1-3).
  - A.** Locate the Fly Station box (containing the frame).
  - B.** Locate the Fly Station cushion box (removed from the main frame assembly).
  - C.** Verify contents of both boxes. See Figures 1-3.

| <b>ITEM</b> | <b>QTY</b> | <b>PART NO.</b> | <b>DESCRIPTION</b>         |
|-------------|------------|-----------------|----------------------------|
| B5          | 1          | 4035S121-0      | Cushion w/Wear Cover       |
| B6          | 1          | 4106S055-0      | Seat Cushion               |
| B8          | 1          | 5245-011        | Back Cushion               |
| B9          | 2          | 4800-135        | Round Cushion w/Wear Cover |
| B12-A       | 1          | 8520-212        | Handle (without bumper)    |
| B12-B       | 1          | 8520-212        | Handle (with bumper)       |
| B16         | 1          | 8620-200        | Frame                      |
| B17         | 1          | 8620-201        | Hip Support                |
| B18         | 1          | 8620-202        | Cushion Mount              |
| B19         | 1          | 8620-203        | Right Pivot                |
| B20         | 1          | 8620-204        | Left Pivot                 |
| B21         | 1          | 8620-207        | Right Pivot Handle         |
| B22         | 1          | 8620-208        | Left Pivot Handle          |
| B23         | 1          | 8620-209        | Right Arm                  |
| B24         | 1          | 8620-210        | Left Arm                   |
| B25         | 1          | 8620-211        | Boom                       |
| B26         | 1          | 8620-214        | Hook                       |
| B42         | 2          | PP080223        | Plastic Insert             |
| B51         | 1          | 8500-201        | Pulldown Bar               |
| B52         | 1          | 8620-002        | Cable 151.25" Long         |
| B53         | 1          | 8620-003        | Cable 65.97" Long          |
| B54         | 1          | 8620-004        | Cable 106.25" Long         |
| B57         | 1          | 8620-338        | Ab Crunch Strap            |
| B58         | 1          | 8620-341        | Guard                      |
|             | 1          |                 | Hardware Pack              |
| B71         | 1          | 8620-215        | Bracket                    |

Figure 1

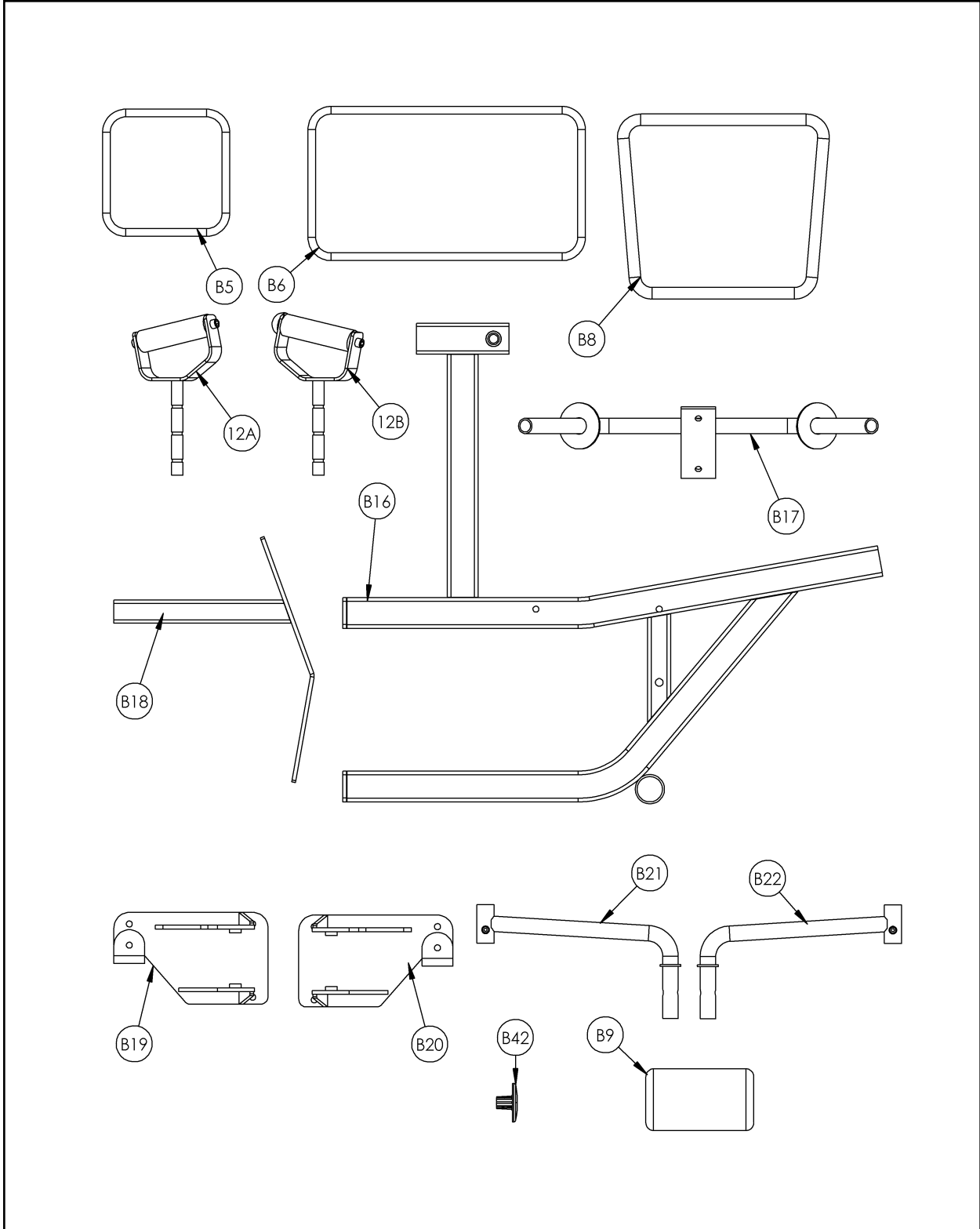

Figure 2

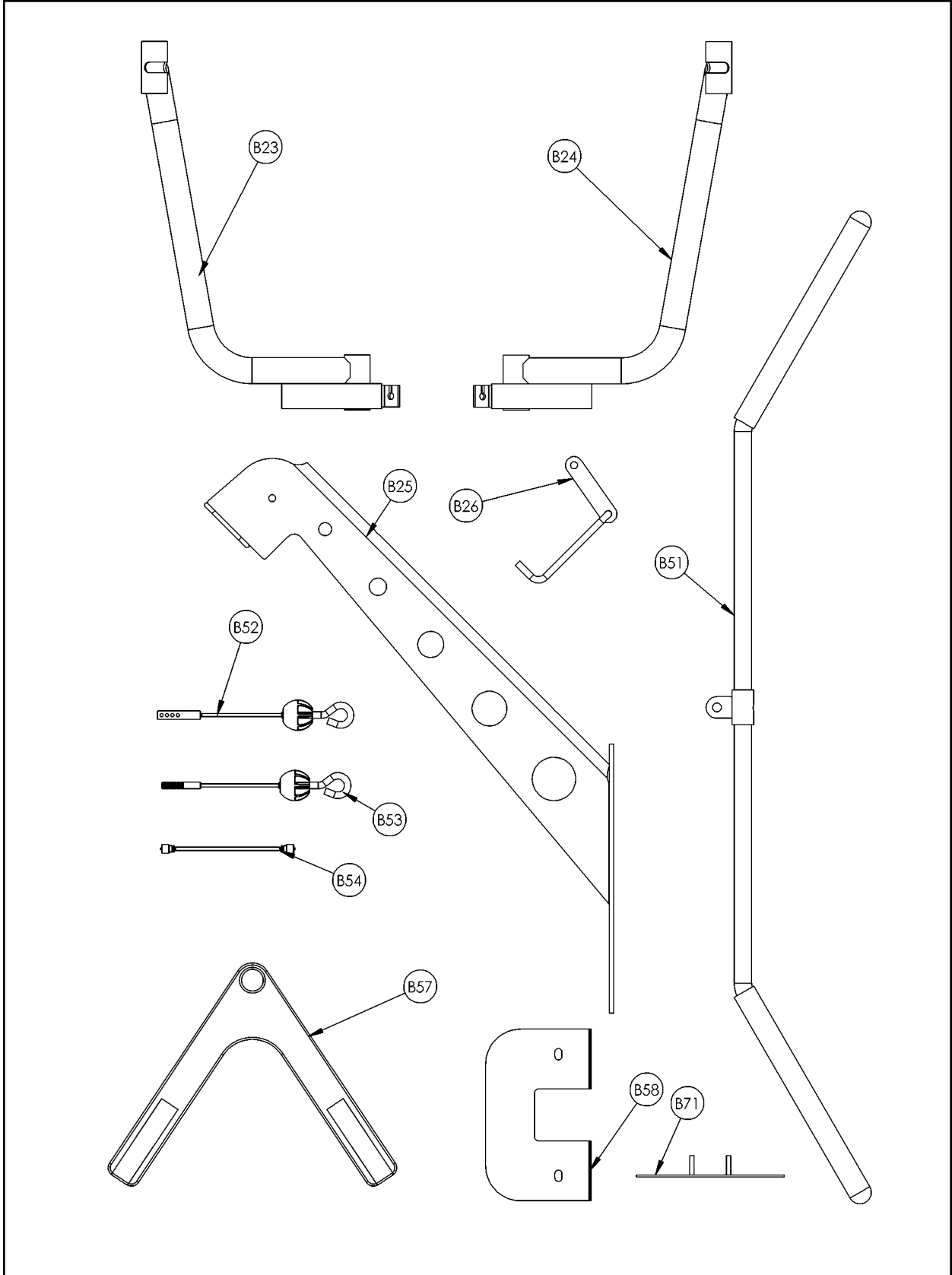

Figure 3

**2. Verify contents of the Fly Station hardware pack** (see steps 2A - 2B and Figures 4 and 5).

**A.** Locate hardware pack from step 1B.

**B.** Verify contents of hardware pack. If desired, sort out hardware into different containers. Do not combine hardware with other hardware packs. See Figures 4 and 5 for contents of hardware pack.

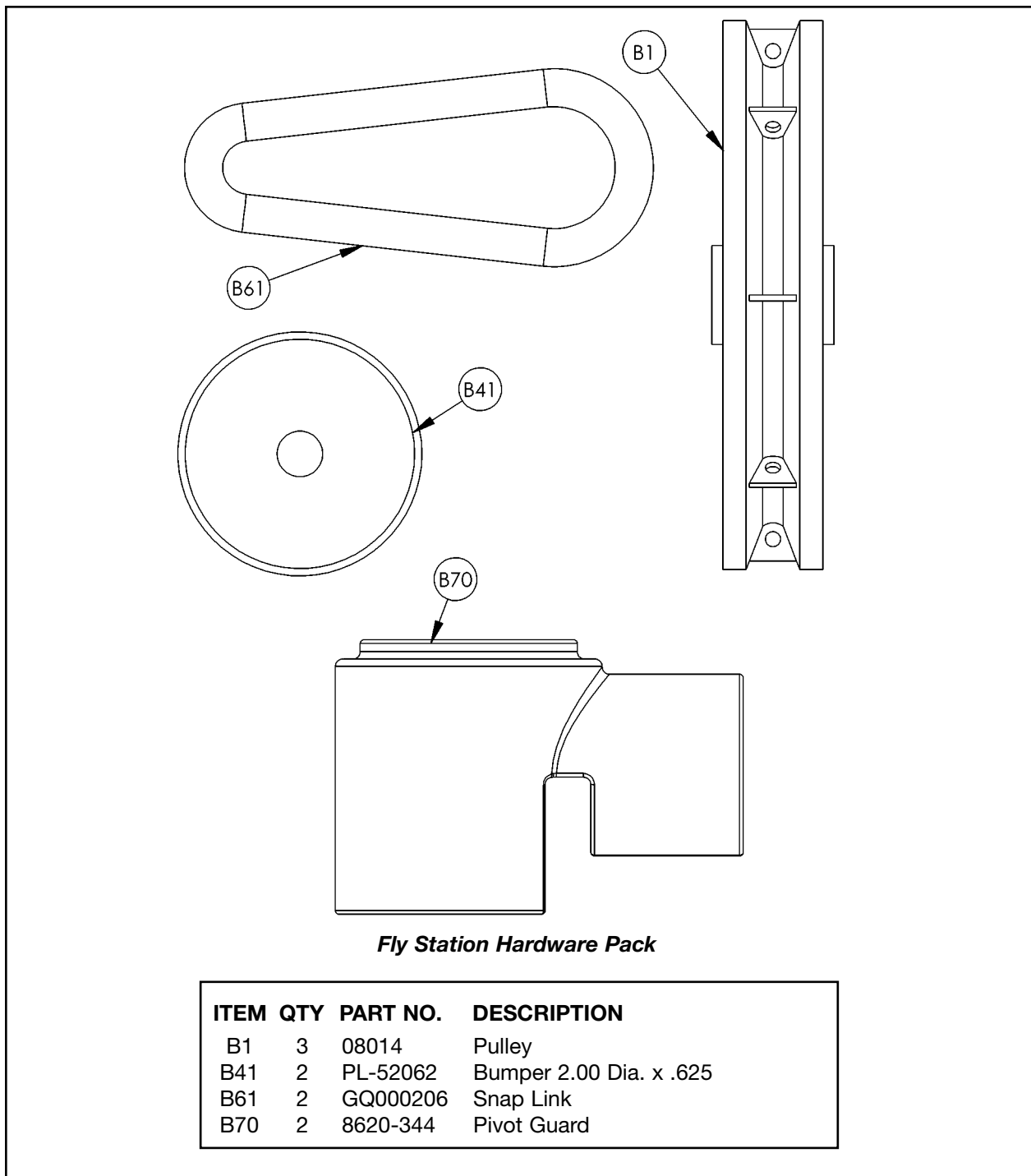

Figure 4

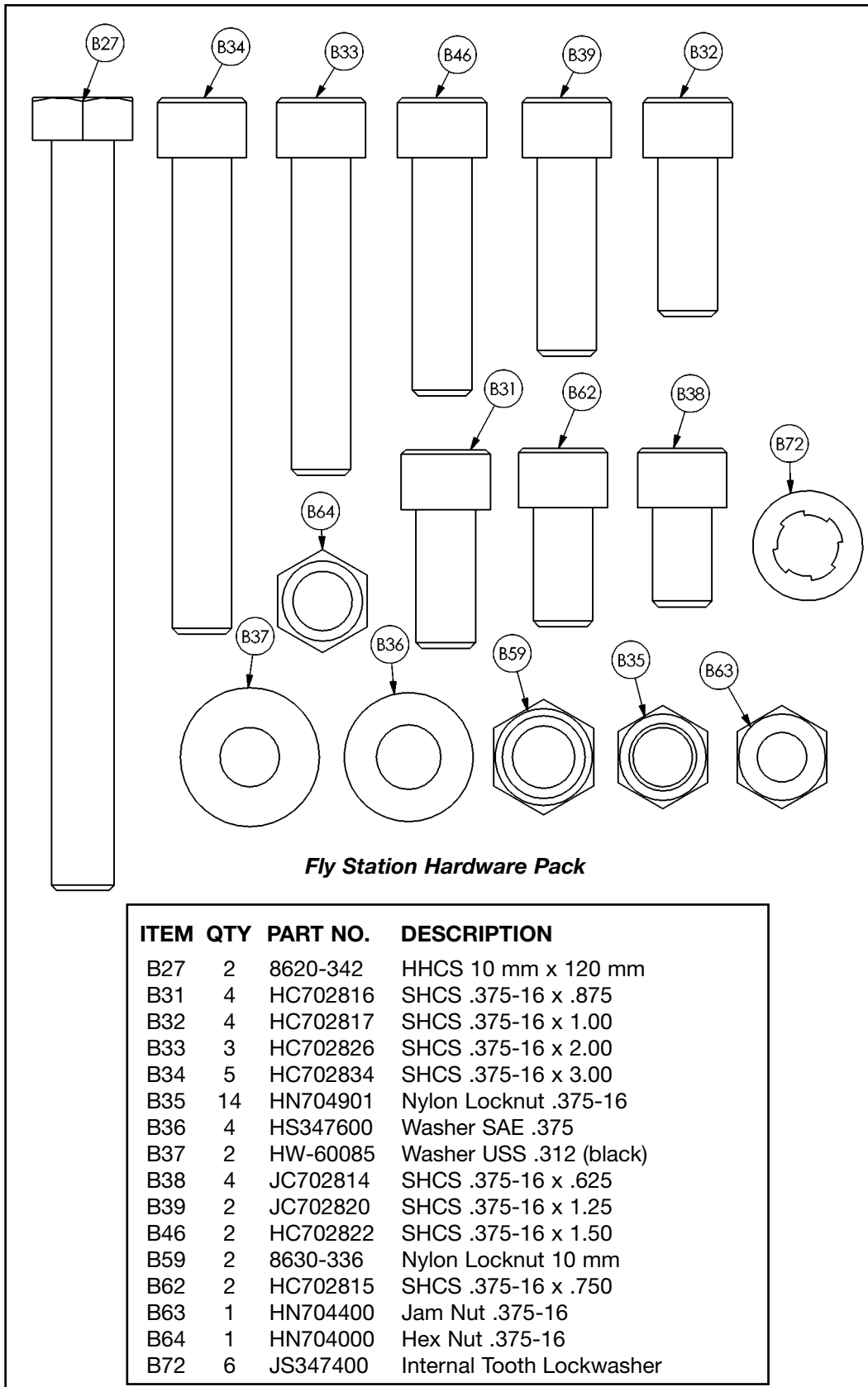

Figure 5

**3. Attach fly frame to main frame assembly** (see steps 3A - 3E and Figure 6).

- A.** Locate the following items: frame (#B16), four SHCS .375-16 x 1.00 (#B32), two flat washers .375 (#B36) and four nylon locknuts .375-16 (#B35).
- B.** Locate the column containing the Fly Station placard. Carefully position Fly frame (#B16) next to the column and align all four holes.
- C.** Insert two SHCS .375-16 x 1.00 (#B32) through the bottom two holes of the Fly frame and attach two nylon locknuts (#B35) as shown in Figure 6. **NOTE:** Do not securely tighten hardware at this time.
- D.** Insert two SHCS .375-16 x 1.00 (#B32) through the top two holes of the Fly frame attach two washers (#B36) and two nylon locknuts (#B35) as shown in Figure 6.
- E.** Securely tighten all hardware installed from steps 3C and 3D.

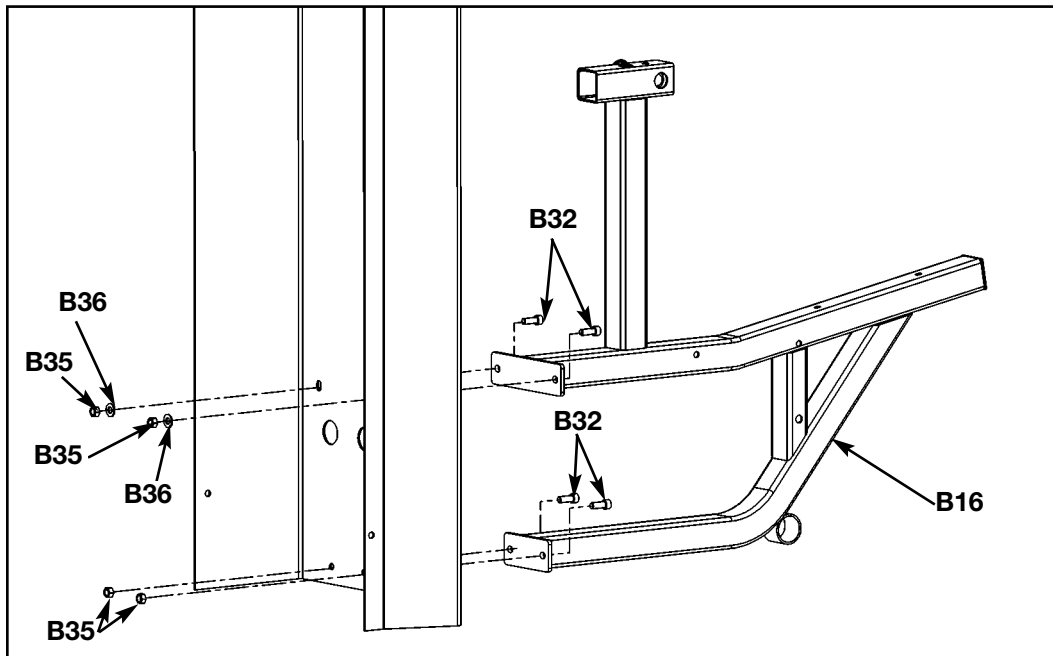

Figure 6

**4. Install left and right pivots** (see steps 4A - 4F and Figures 7 - 9).

- A.** Locate the following items: left pivot (#B19), right pivot (#B20), two round bumpers (#B41), two SHCS .375-16 x .750 (#B62).
- B.** Attach bumpers (#B41) to pivots (#B19 and #B20) using two SHCS .375-16 x .750 (#B62) as shown in Figure 7. Securely tighten hardware.

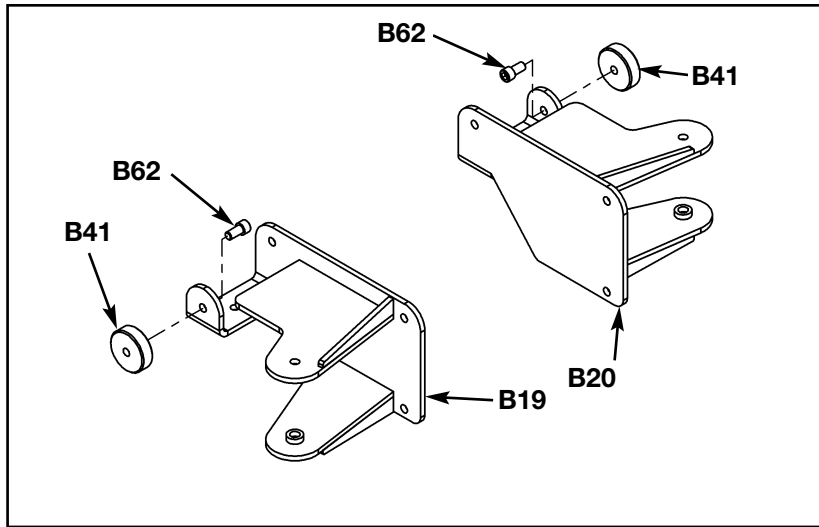

Figure 7

- C.** Locate three SHCS .375-16 x 3.00 (#B34) and three nylon locknuts .375-16 (#B35).
- D.** Install pivots (#B19 and #B20) using three SHCS .375-16 x 3.00 (#B34) and three nylon locknuts (#B35) as shown in Figure 8. Securely tighten hardware.

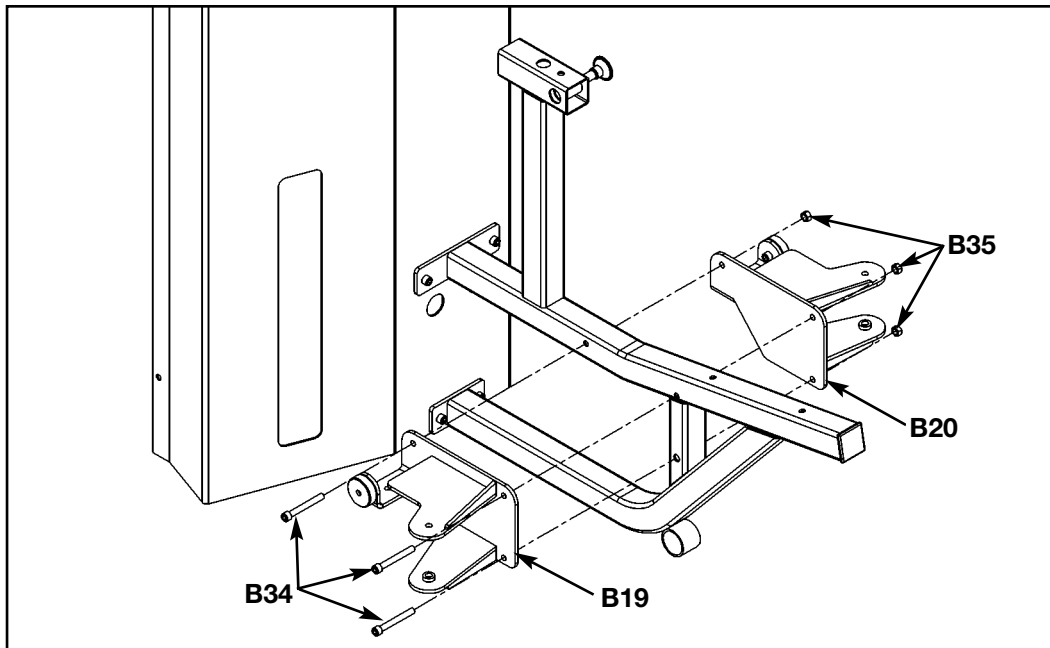

Figure 8

- E.** Locate guard (#B58), two pulleys (#B1), two SHCS .375-16 x 2.00 (#B33), two nylon locknuts .375-16 (#B35) and bracket (#B71).
- F.** Install guard (#B58), pulleys (#B1) and bracket (#B71) using two SHCS .375-16 x 2.00 (#B33) and two nylon locknuts (#B35) as shown in Figure 9.

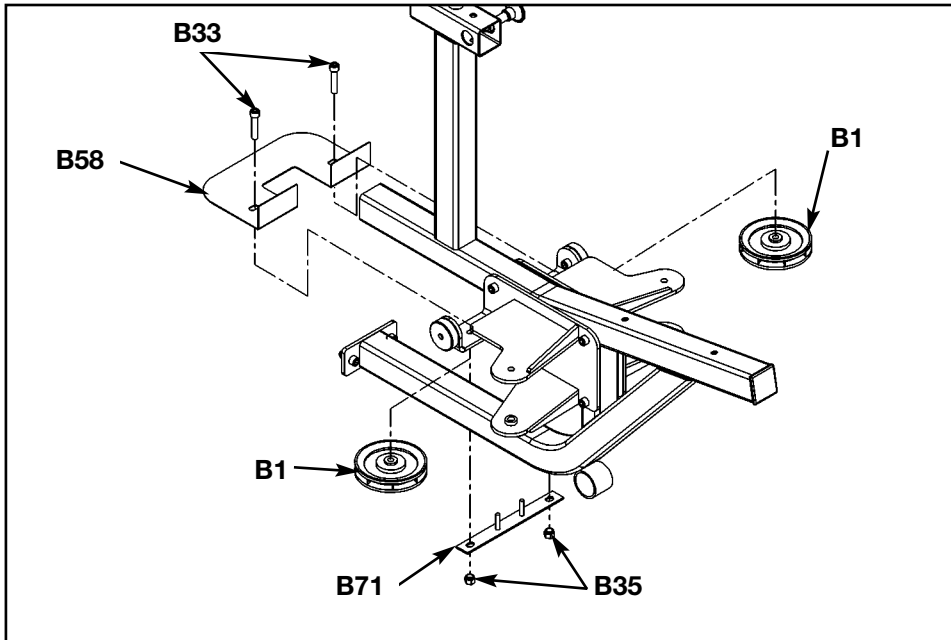

Figure 9

**5. Install left and right arms** (see steps 5A, 5B and Figure 10).

- A.** Locate (user position) right arm (#B23) and left arm (#B24), two HHCS 10 mm x 120 mm (#B27) and two locknuts 10 mm (#B59).
- B.** Install (user position) right arm (#B23) using HHCS 10 mm x 120 mm (#B27) and locknut 10 mm (#B59). See Figure 10. Repeat this step for installing the left arm (#B24).

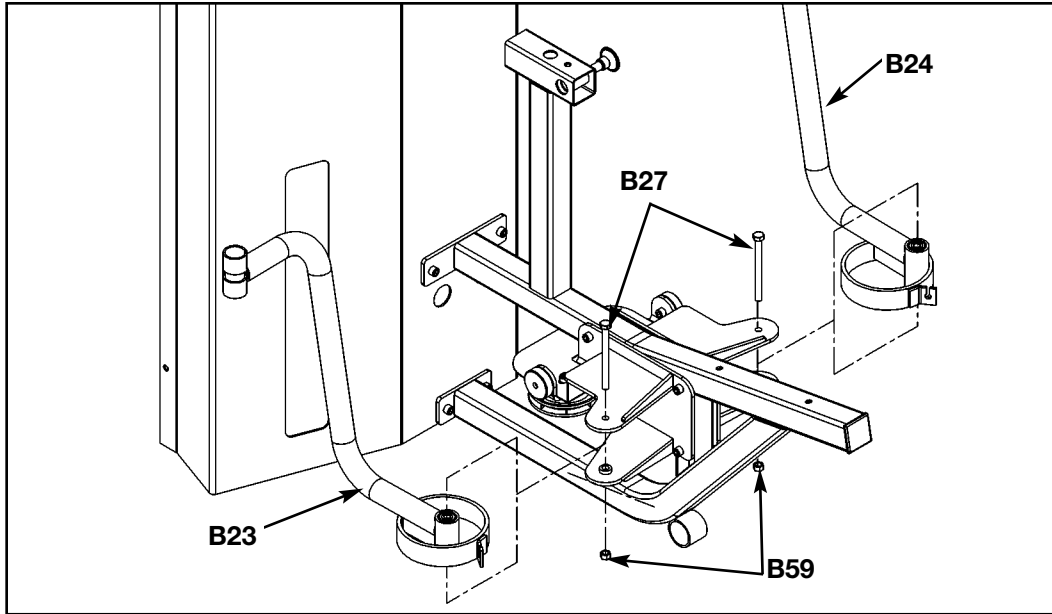

Figure 10

**6. Install left and right pivot handles** (see steps 6A - 6F, Figures 11A - 13).

- A.** Locate pivot handles (#B21 and #B22), two SHCS .375-16 x .625 (#B38) and two pivot guards (#B70).
- B.** Slide pivot guard (#B70) onto (user position) right pivot handle (#B21). See Figure 11A.

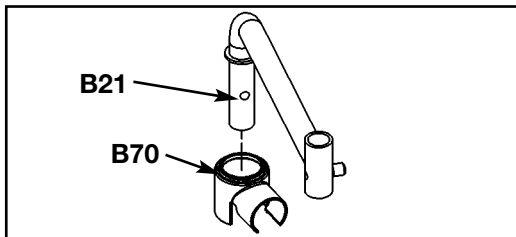

Figure 11A

- C.** Secure right pivot handle (#B21) to right arm (#B23) using SHCS .375-16 x .625 (#B38). See Figure 11B.

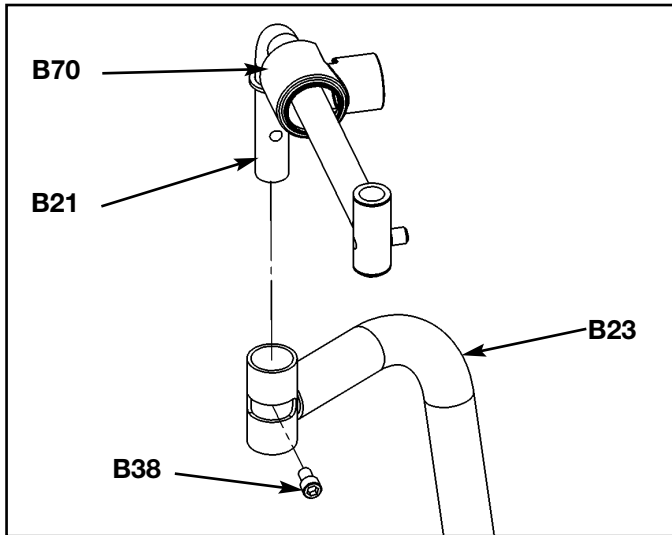

Figure 11B

- D.** Slide guard (#B70) downward and snap into place. See Figure 11C.

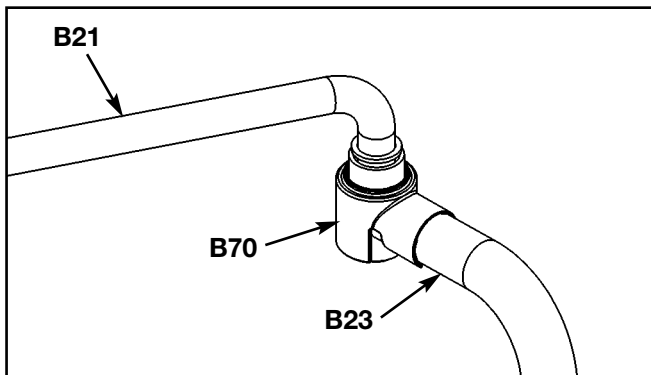

Figure 11C

- E.** Repeat steps B - D to install the other pivot guard (#B70) and left pivot handle (#B22).

**7. Install handles** (see steps 7A - 7C, Figures 12A and 12B).

- A.** Locate both pivot handles (#B12), two black flat washers (#B37) and two SHCS .375-16 x .625 (#B38).
- B.** Install handle (#B12-A - without bumper) on user position right side using one black flat washer (#B37) and one SHCS .375-16 x .625 (#B38) as shown in Figure 12A.
- C.** Install handle (#B12-B - with bumper) on user position left side using one black flat washer (#B37) and one SHCS .375-16 x .625 (#B38) as shown in Figure 12B.

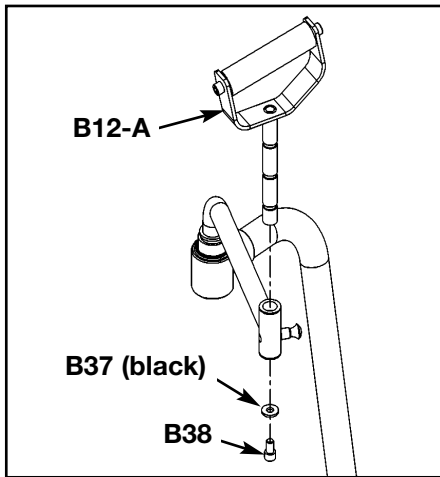

Figure 12A

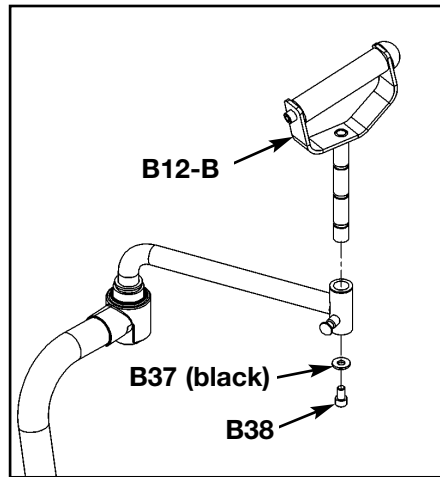

Figure 12B

**8. Install cushion supports and cushions** (see steps 8A - 8I and Figures 13 - 15).

- A.** Locate cushion mount (#B18), hip support (#B17), back cushion (#B8), cushion (#B5), two round cushions (#B9), two plastic inserts (#B42), two SHCS .375-16 x 1.50 (#B46), two SHCS .375-16 x 1.25 (#B39) and six internal tooth lockwashers (#B72).
- B.** Slide round cushions (#B9) onto cushion mount (#B18).
- C.** Slide cushion mount (#B18) onto frame as shown in Figure 13.
- D.** Slide both round cushions (#B9) onto cushion mount (#B18).
- E.** Install back cushion (#B8) to cushion mount (#B18) using two SHCS .375-16 x 1.25 (#B39) and two internal tooth lockwashers (#B72).
- F.** Install cushion (#B5) and hip support (#B17) to cushion mount (#B18) using two SHCS .375-16 x 1.50 (#B46) and two internal tooth lockwashers (#B72).

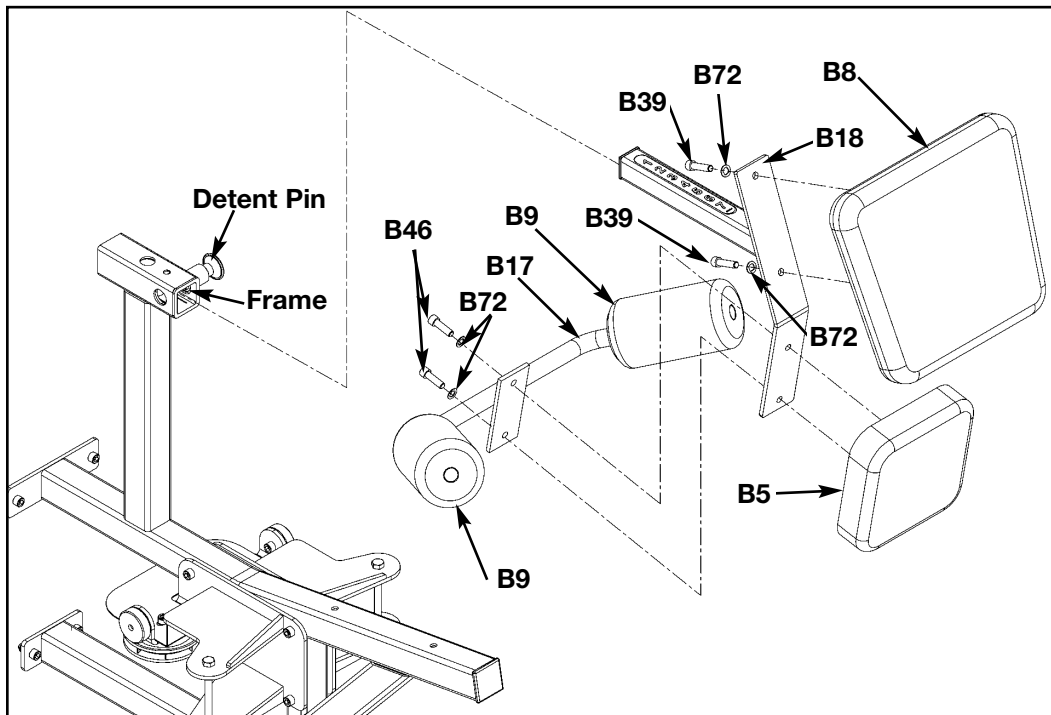

Figure 13

- G.** Using a rubber mallet, install plastic inserts (#B42) to secure round cushions (#B9) on hip support (#B17) as shown in Figure 14.

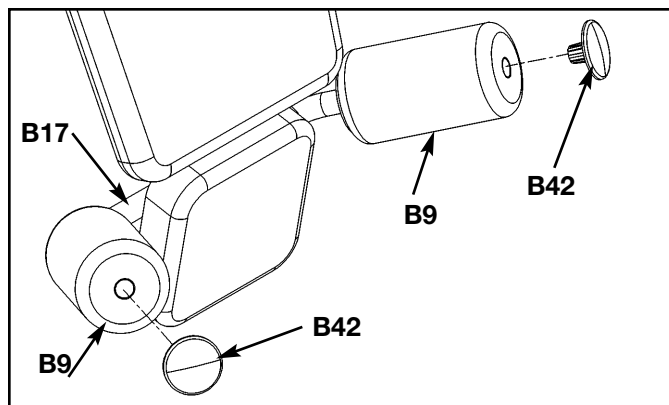

Figure 14

- H. Locate seat cushion (#B6), two SHCS .375-16 x 3 (#B34) and two internal tooth lockwashers (#B72). See Figure 15.
- I. With seam in back, install seat cushion as shown in Figure 15.

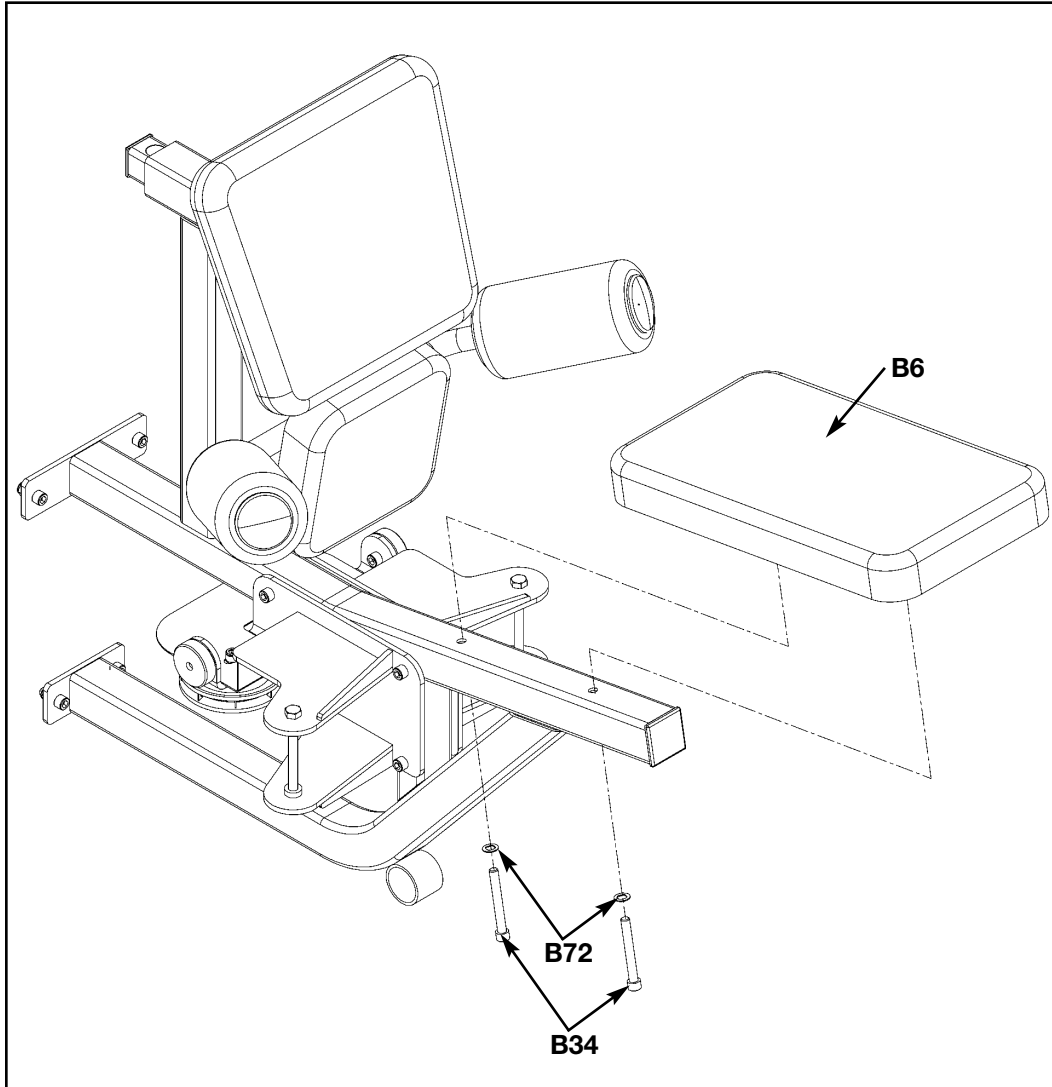

Figure 15

**9. Install upper boom** (see steps 9A - 9D, Figures 16 and 17).

- A.** Locate upper boom (#B25), four SHCS .375-16 x .875 (#B31), four locknuts .375-16 (#B35) and two flat washers .375 (#B36).
- B.** With an assistant install upper boom (#B25) as shown in Figure 18 using the four SHCS .375-16 x .875 (#B31) and four nylon locknuts (#B35).

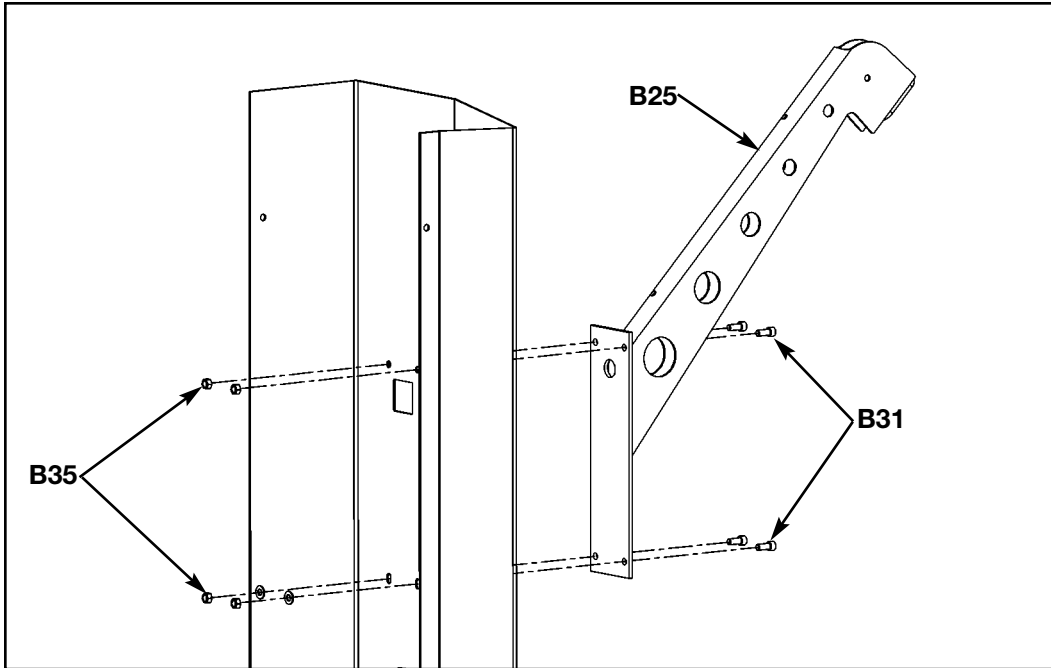

Figure 16

- C. Locate weight stack cable (#B52), one pulley (#B1), one SHCS .375-16 x 2.00 (#B33), one nylon locknut .375-16 (#B35) and hook (#B26).
- D. Assemble pulley (#B1), hook (#B26) into boom and route cable (#B52) around pulley. Secure using SHCS .375-16 x 2.00 (#B33) and locknut (#B35). Route cable downward through boom. See Figure 17.

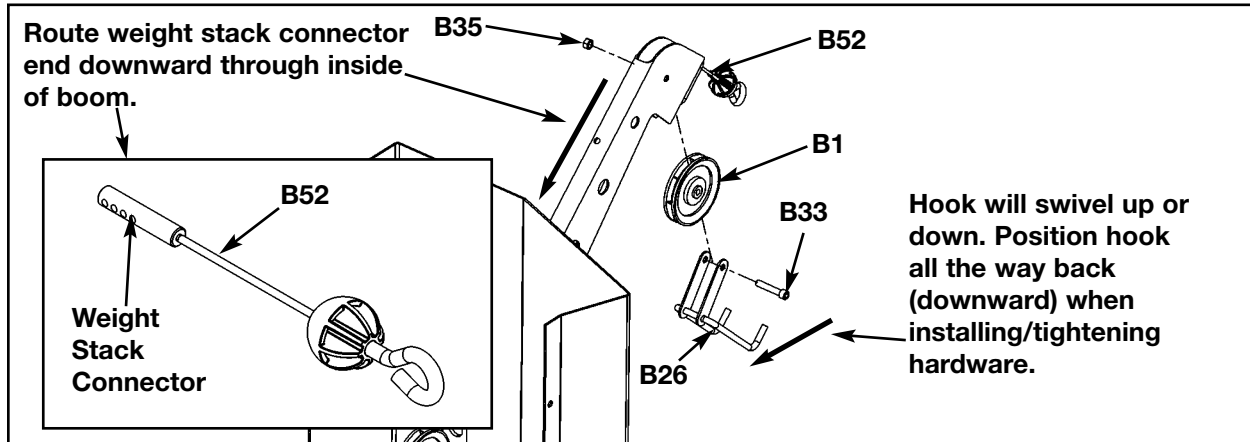

Figure 17

**10. Route weight stack cable around pulleys to weight stack** (see steps 10A - 10G and Figure 18).

From the main frame hardware pack, locate five pulleys (#E1), four SHCS .375-16 x 1.75 (#E39), one SHCS .375-16 x 3.00 (#E33), five nylon lock-nuts .375-16 (#E34), one spiral pin (#E35), two spacers (#E8), one pulley tab (#E19), one adjuster (#E14) and one cable retainer (#E44).

- A.** At the same time, route cable (#B52) and install first pulley (#E1) on inside of column using one SHCS .375-16 x 1.75 (#E39) and one nylon locknut .375-16 (#E34). See Figure 18, letter A.
- B.** At the same time, route cable (#B52) and install second pulley (#E1) using one SHCS .375-16 x 1.75 (#E39) and one nylon locknut .375-16 (#E34). See Figure 18, letter B.
- C.** At the same time, route cable (#B52) and install third pulley (#E1), pulley tab (#E19), adjuster (#E14), cable retainer (#E44) and route cable (#B52). Use SHCS .375-16 x 3.00 (#E33), two spacers (#E8) and nylon locknut (#E34). See Figure 18, letter C. **NOTE:** Tab on bracket needs to be located on the outside.
- D.** With an assistant holding the hanging pulley installed in step C, route cable (#B52) upward and install fourth pulley (#E1) one using adjuster (#E14), one pulley tab (#E19), one SHCS .375-16 x 3.00 (#E33) and one nylon locknut (#E34). See Figure 18, letter D. Verify cable is resting between the pulley (E1) and the retainer tab.

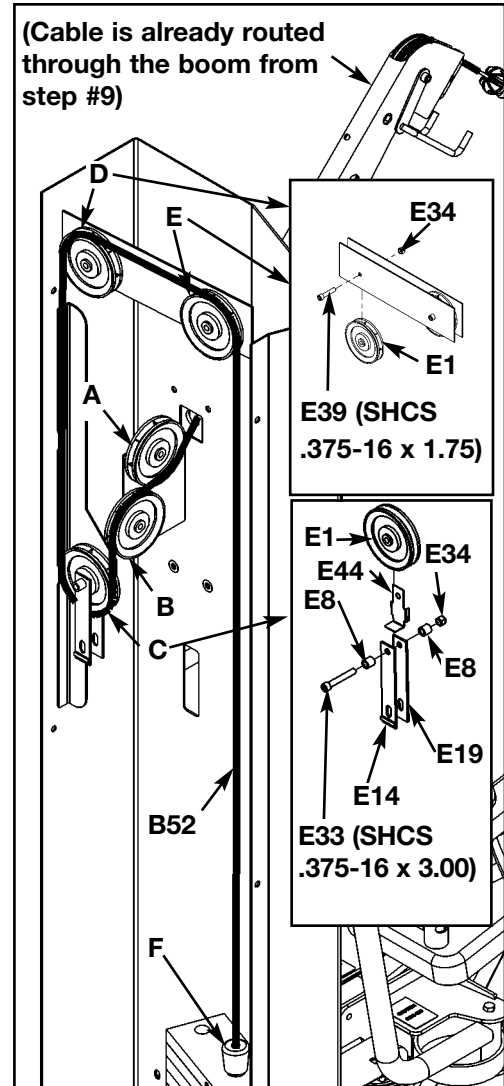

Figure 18

- E.** With an assistant holding the hanging pulley, (at the same time) route cable (B#52) and install fifth pulley (#E1) using one SHCS .375-16 x 1.75 (#E39) and one nylon locknut (#E34). See Figure 18, letter E.
- F.** Route cable (#B52) down to weight stack. Slide rubber boot (#E3) on cable.
- G.** Drive a spiral pin (#E35) through top weight connector and cable. Top weight should be snug (just resting) on the second plate.

**NOTE:** All cables (for all three stations) will be adjusted for tension at the very end of the assembly procedure.

**11. Routing second cable** (see steps 11A - 11E and Figure 19).

From the main frame hardware pack, locate three pulleys (#E1), one SHCS .375-16 x 1.75 (#E39), one SHCS .375-16 x 3.00 (#E33), one cam bolt (#E13), two spacers (#E8), one washer .375 (#E37), one pulley clevis (#E12), three nylon locknuts .375-16 (#E34) and two cable retainers (#E44). From the Fly Station hardware pack, locate locate cable (#B53), one hex nut (#B64) and one jam nut (#B63).

- A.** Route cable (#B53) through pulley slot in column. Be sure ball on cable is on the outside of the column. See Figure 19, letter A.
- B.** At the same time route cable (#B53) and install the first pulley (#E1) using one SHCS .375-16 x 1.75 (#E39) and one nylon locknut (#E34) as shown in Figure 19, letter B.
- C.** At the same time route cable (#B53) and install pulley clevis (#E12), pulley (#E1) and cable retainer (#E44) using one SHCS .375-16 x 3.00 (#E33), one nylon locknut (#E34) and two spacers (#E8). See Figure 19, letter C. Verify cable is resting between the pulley (#E1) and the retainer tab.
- D.** At the same time route cable (#B53) and Install the third pulley (#E1) and cable retainer (#E44) using one cam bolt (#E13), one washer (#E37) and one nylon locknut (#E34). Verify that the tab on the bracket is facing outward and also verify that the cable is resting between the pulley (#E1) and the retainer tab. See Figure 19, letter D.
- E.** Route cable (#B53) downward and install hex nut (#B64) and then jam nut (#B63). Jam nut should be flush with end of cable and hex hut should be snug against jam nut, do not over tighten. Be sure brackets are snug in the "V" slots. See Figure 19, letter E.

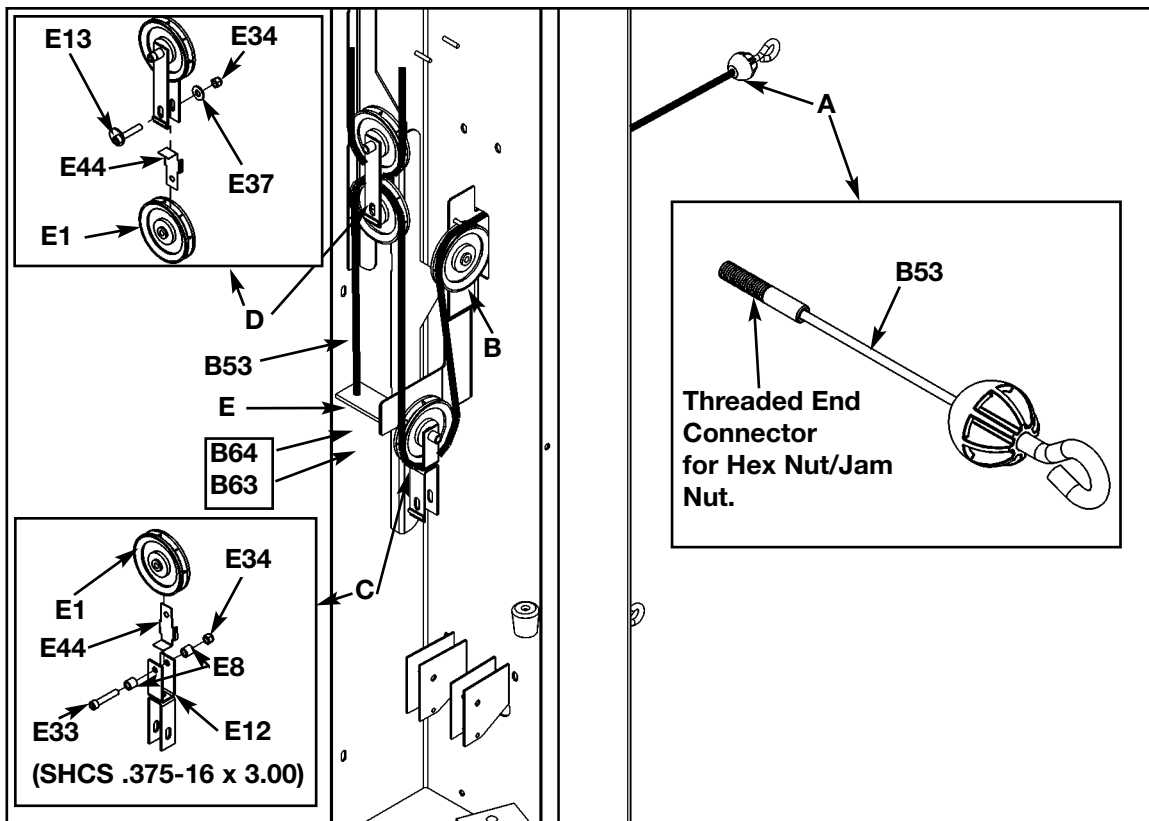

Figure 19

**12. Routing cam cable** (see steps 12A - 12H and Figure 20).

Locate cable (#B54) from the Fly Station hardware pack. From the main frame hardware pack, locate three pulleys (#E1), one cable retainer (#E44), two SHCS .375-16 x 1.75 (#E39), one cam bolt (#E13), one washer .375 (#E37) and three nylon locknuts (#E34).

- A.** Place one end of cable (#B54) in the cable slot of (user position) right cam arm and route cable to first pulley (#B1). See Figure 20, letter A.
- B.** The first pulley (#B1) is already installed. Route cable (#B54) around the first pulley (#B1) as shown in Figure 20, letter B.
- C.** At the same time install second pulley (#E1) and route cable (#B54) using one SHCS .375-16 x 1.75 (#E39) and one nylon locknut (#E34). See Figure 20, letter C.
- D.** At the same time install cable retainer (#E44), third pulley (#E1) and route cable (#B54) using cam bolt (#E13), washer (#E37) and nylon locknut. See Figure 20, letter D.
- E.** At the same time install fourth pulley (#E1) and route cable (#B54) using one SHCS .375-16 x 1.75 (#E39) and one nylon locknut (#E34). Verify cable is resting between the pulley (#E1) and the retainer tab. See Figure 20, letter E.
- F.** The fifth pulley (#B1) is already installed. Route cable (#B54) as shown in Figure 20, letter F.
- G.** Finish routing cable and place cable end in slot. See Figure 20, letter G.
- H.** Adjust cam bolt (#E13) until cable (#B54) is snug. Be sure bracket is snug in the "V" slot.

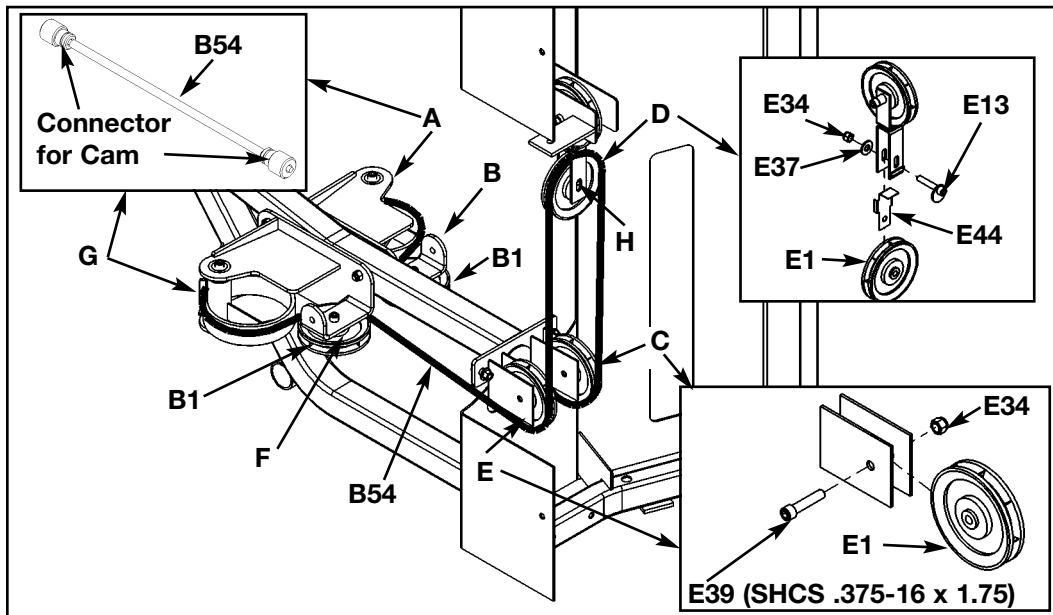

Figure 20

13. Verify warning decals are present and not damaged (see decals below and Figure 21).

**A** →

|  |  |
|--|--|
| <p><b>! WARNING</b></p> <p><b>SERIOUS INJURY<br/>COULD OCCUR IF<br/>THESE PRECAUTIONS<br/>ARE NOT OBSERVED</b></p> | <ol style="list-style-type: none"> <li>1. Obtain a medical exam prior to beginning an exercise program.</li> <li>2. Read all warnings and obtain proper instruction on use of the machine prior to using.</li> <li>3. Keep body and clothing free from and clear of all moving parts.</li> <li>4. Inspect machine prior to use. DO NOT use if it appears damaged or inoperable.</li> <li>5. DO NOT attempt to fix a broken or jammed machine. Notify floor staff.</li> <li>6. Use the machine only for the intended use. DO NOT modify the machine.</li> <li>7. Be sure that the weight pin is completely inserted. Use only the pin provided by the manufacturer. If unsure seek assistance.</li> <li>8. Never pin the weights in an elevated position. DO NOT use the machine if found in this condition. Seek assistance from floor staff.</li> <li>9. Children must not be allowed near this machine. Teenagers must be supervised.</li> <li>10. DO NOT use if guards are missing or damaged.</li> <li>11. DO NOT use dumbbells or other incremental weights, except those provided by the manufacturer.</li> <li>12. Inspect all cables and belts and connections prior to use. DO NOT use if any components are worn, frayed, or damaged.</li> <li>13. DO NOT REMOVE THIS LABEL. REPLACE IF DAMAGED.</li> </ol> <p style="text-align: right;">4800-381 B</p> |
|--|--|

**B** →

**! CAUTION**

**Failure to correctly adjust could result in personal injury.**

**Always fully engage the detent pin before use to avoid injury.**

8500-025 B

**C** →

**! CAUTION**



**Keep away from moving parts. Failure to do so could result in personal injury.**

8500-026 A

**D** →

**! WARNING**

**Support hooks will not support body weight.**

**Do not hang from bar to avoid injury.**

8620-343 A

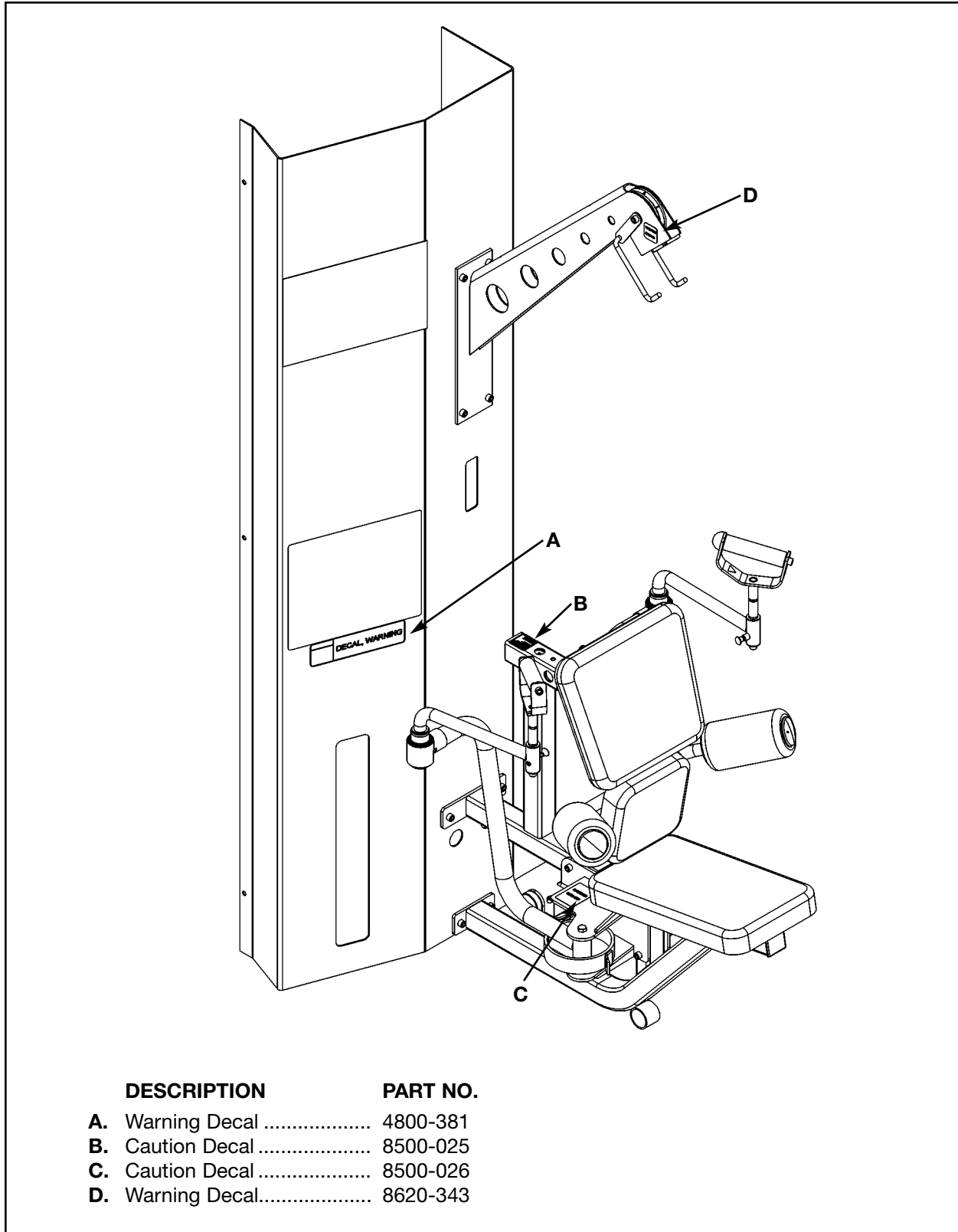
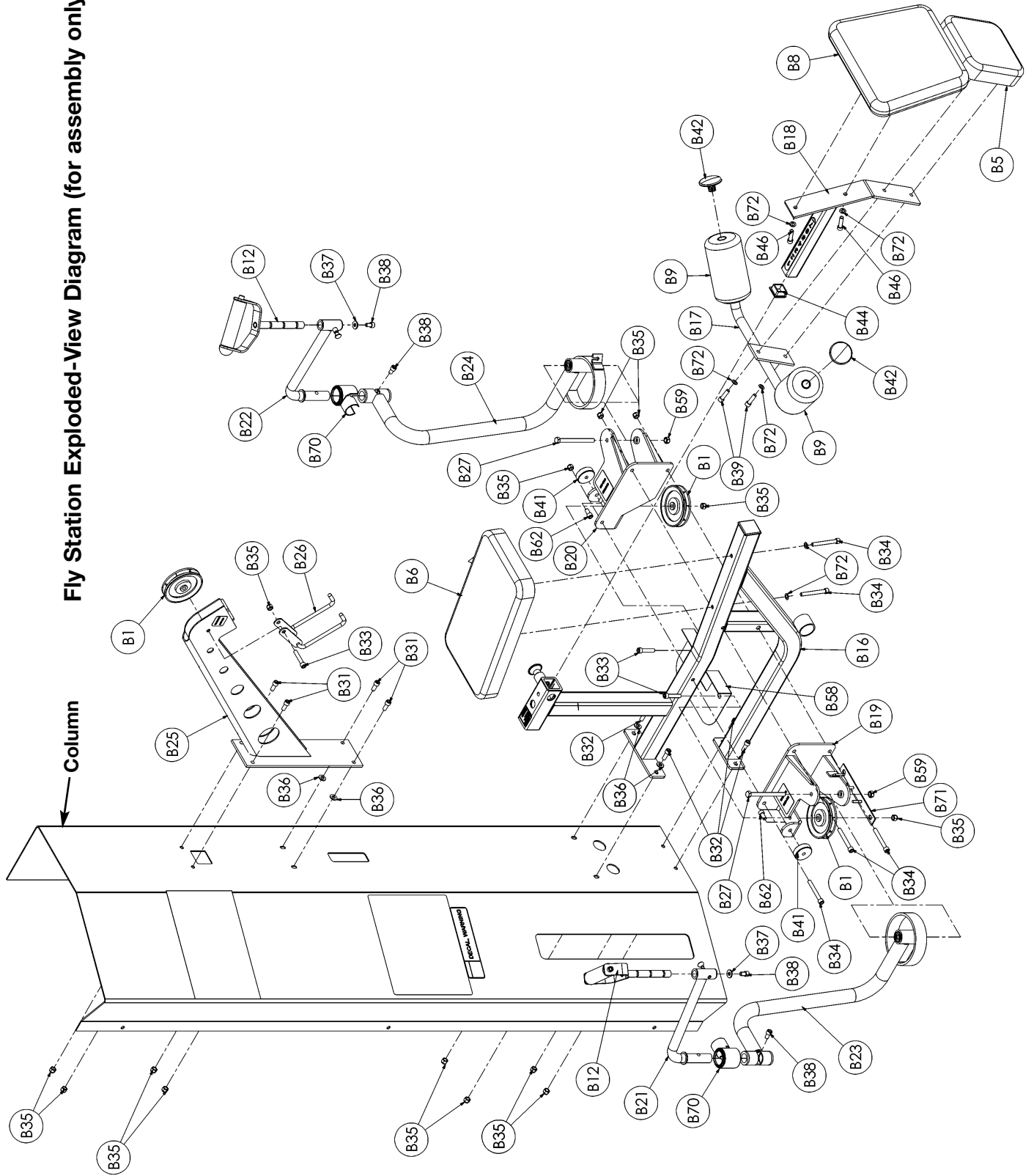

Figure 21

Fly Station Exploded-View Diagram (for assembly only)



**Fly Station Parts List (not all parts are listed such as pulleys for inside of MG 500 and handles).  
See Chapter 8 for a complete parts listing.**

| ITEM | QTY | PART NO.   | DESCRIPTION              |
|------|-----|------------|--------------------------|
| B1   | 3   | 08014      | Pulley                   |
| B5   | 1   | 4035S121-0 | Cushion                  |
| B6   | 1   | 4106S055-0 | Seat Cushion             |
| B8   | 1   | 5245-011   | Back Cushion             |
| B12  | 2   | 8520-212   | Handle (one with bumper) |
| B16  | 1   | 8620-200   | Frame                    |
| B17  | 1   | 8620-201   | Hip Support              |
| B18  | 1   | 8620-202   | Slide Cushion Mount      |
| B19  | 1   | 8620-203   | Right Pivot              |
| B20  | 1   | 8620-204   | Left Pivot               |
| B21  | 1   | 8620-207   | Right Hand Pivot Handle  |
| B22  | 1   | 8620-208   | Left Hand Pivot Handle   |
| B23  | 1   | 8620-209   | Right Arm                |
| B24  | 1   | 8620-210   | Left Arm                 |
| B25  | 1   | 8620-211   | Boom                     |
| B26  | 1   | 8620-214   | Hook                     |
| B27  | 2   | 8620-342   | HHCS 10 mm x 120 mm      |
| B31  | 4   | HC702816   | SHCS .375-16 x .875      |
| B32  | 4   | HC702817   | SHCS .375-16 x 1.00      |

| ITEM | QTY | PART NO. | DESCRIPTION                      |
|------|-----|----------|----------------------------------|
| B33  | 3   | HC702826 | SHCS .375-16 x 2.00              |
| B34  | 5   | HC702834 | SHCS .375-16 x 3.00              |
| B35  | 14  | HN704901 | Nylon Locknut                    |
| B36  | 4   | HS347600 | Flat Washer                      |
| B37  | 2   | HW-60085 | Washer .3125                     |
| B38  | 4   | JC702814 | SHCS .375-16 x .625              |
| B39  | 2   | JC702820 | SHCS .375-16 x 1.25              |
| B40  |     |          | Removed 10/02                    |
| B41  | 2   | PL-52062 | Bumper 2.00 Dia. x .625          |
| B42  | 2   | PP080223 | Plastic Insert                   |
| B44  | 1   | PP090211 | Plastic Insert 1.50 Sq x 10-14 G |
| B46  | 2   | HC702822 | SHCS .375-16 x 1.50              |
| B58  | 1   | 8620-341 | Guard                            |
| B59  | 2   | 8630-336 | Nylon Locknut 10 mm              |
| B62  | 5   | HC702815 | SHCS .375-16 x .750              |
| B70  | 2   | 8620-344 | Pivot Guard                      |
| B71  | 1   | 8620-215 | Bracket                          |
| B72  | 6   | JS347400 | Internal Tooth Lockwasher        |

*This page intentionally left blank*

**Leg Press Diagram**

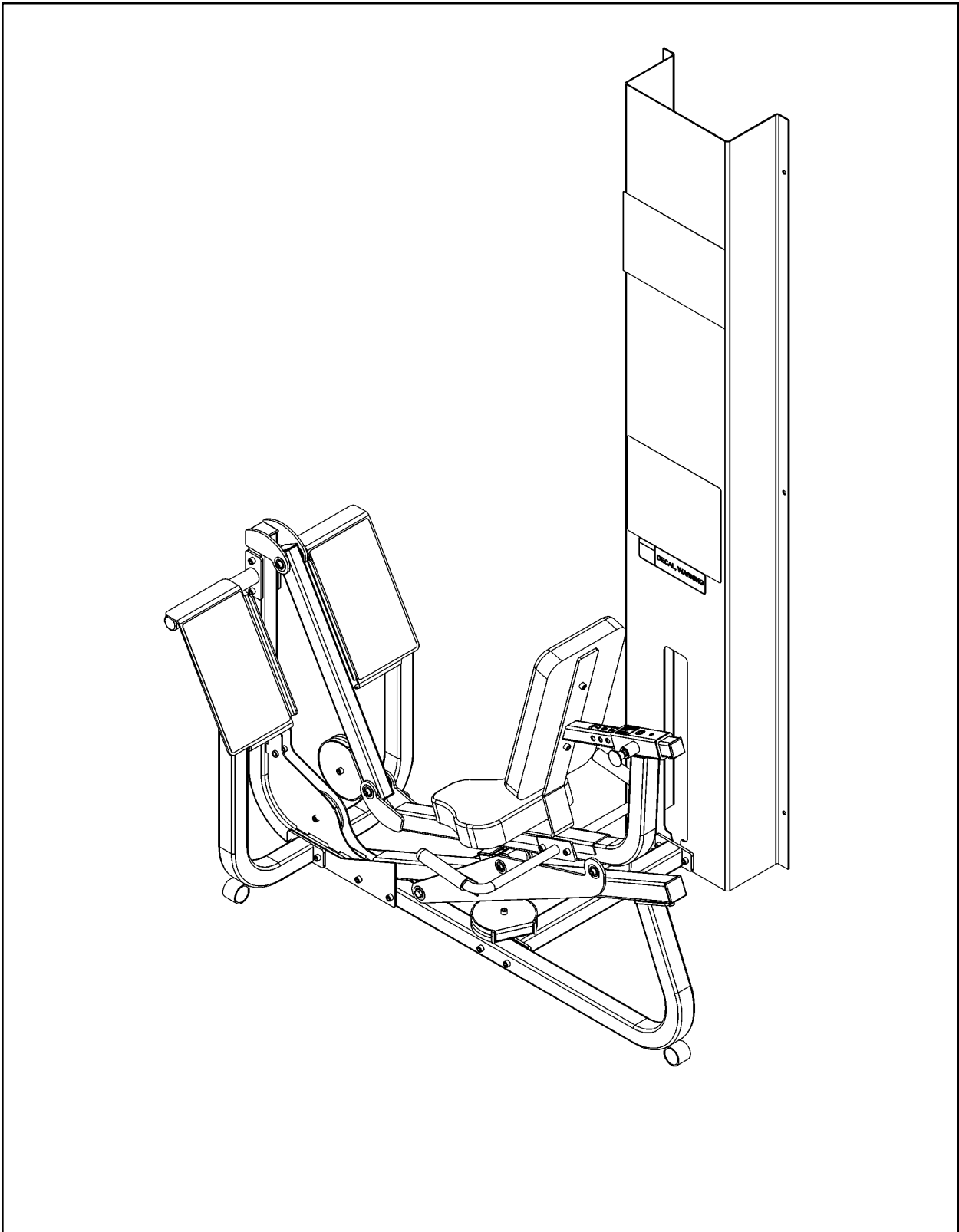

**Leg Press Assembly**

**1. Verify contents of the Leg Press Station boxes** (see steps 1A - 1C, Figures 1-3).

- A.** Locate the Leg Press Station box (containing the frame).
- B.** Locate the Leg Press cushion box (removed from the main frame assembly).
- C.** Verify contents of both boxes. See Figures 1-3.

| <b>ITEM</b> | <b>QTY</b> | <b>PART NO.</b> | <b>DESCRIPTION</b>  |
|-------------|------------|-----------------|---------------------|
| C6          | 1          | 4106S055-0      | Back Cushion        |
| C9          | 1          | 4800-026        | Seat Cushion        |
| C14         | 1          | 8630-200        | Frame               |
| C15         | 1          | 8630-201        | Seat Frame          |
| C16         | 1          | 8630-202        | Seat Tube           |
| C17         | 1          | 8630-203        | Right Foot Plate    |
| C18         | 1          | 8630-204        | Left Foot Plate     |
| C19         | 1          | 8630-205        | Roller Tube         |
| C20         | 1          | 8630-206        | Roller Plate        |
| C21         | 1          | 8630-207        | Right Handle        |
| C22         | 1          | 8630-208        | Left Handle         |
| C23         | 1          | 8630-209        | Pivot Tube          |
| C24         | 1          | 8630-210        | Connector           |
| C27         | 1          | 8630-326        | Plastic Seat Sleeve |
| C46         | 1          | 8630-002        | Cable 216.50" Long  |
|             | 1          |                 | Hardware Pack       |

Figure 1

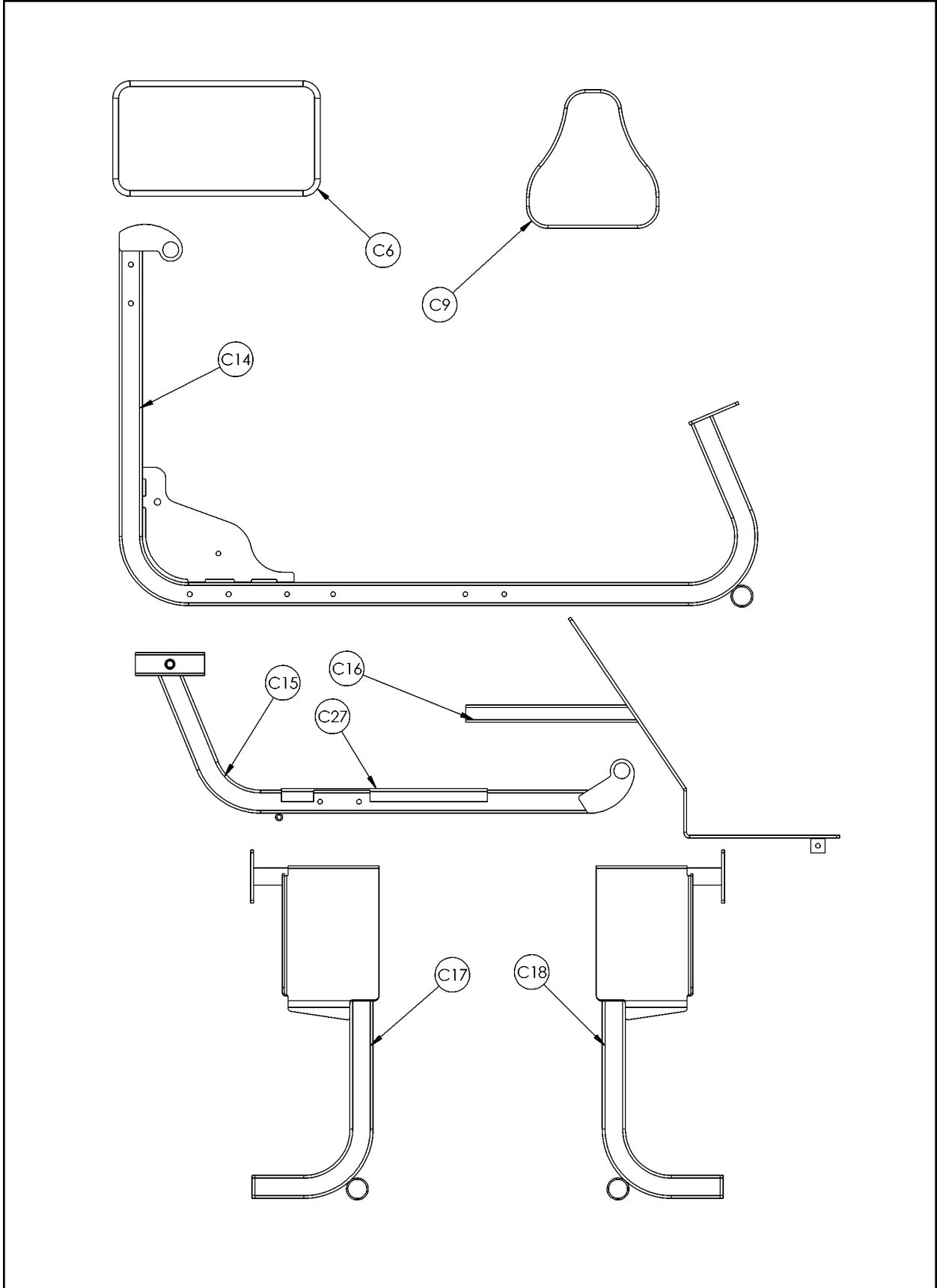

Figure 2

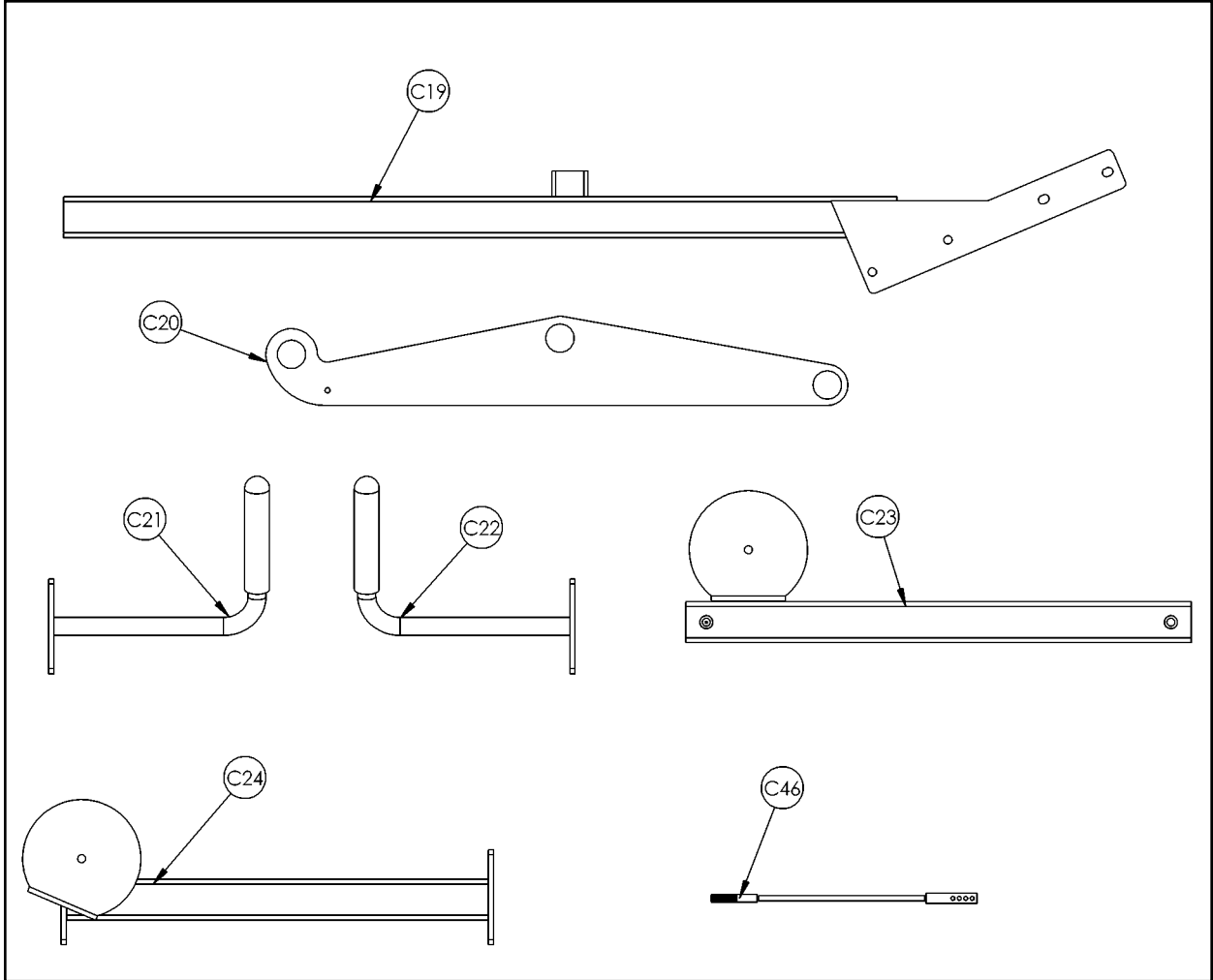

Figure 3

**2. Verify contents of the Leg Press Station hardware pack** (see steps 2A, 2B, Figures 4 and 5).

**A.** Locate hardware pack from step 1.

**B.** Verify contents of hardware pack. If desired, sort out hardware into different containers. Do not combine hardware with other hardware packs. Refer to Figures 4 and 5 for contents of hardware pack.

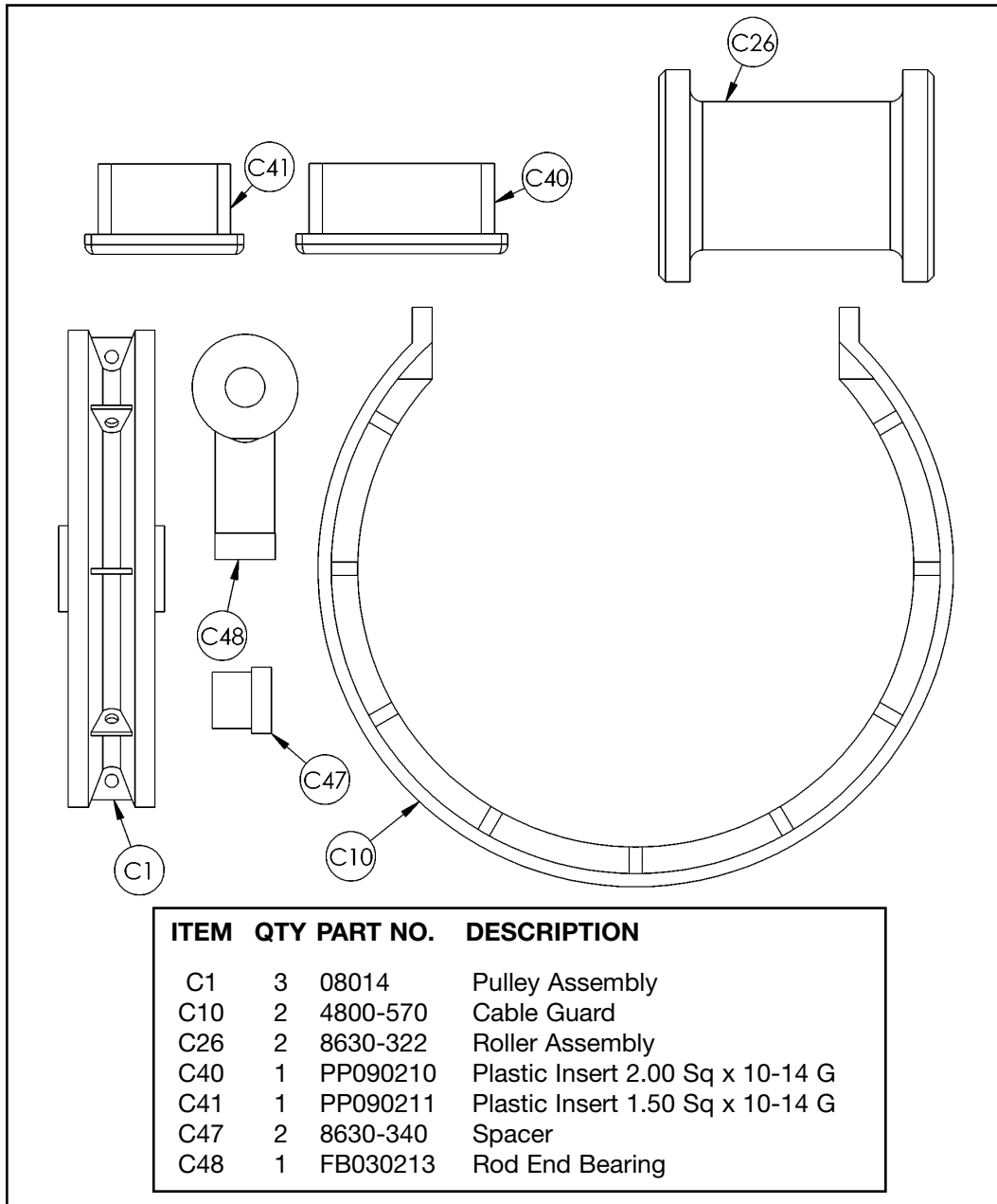

Figure 4

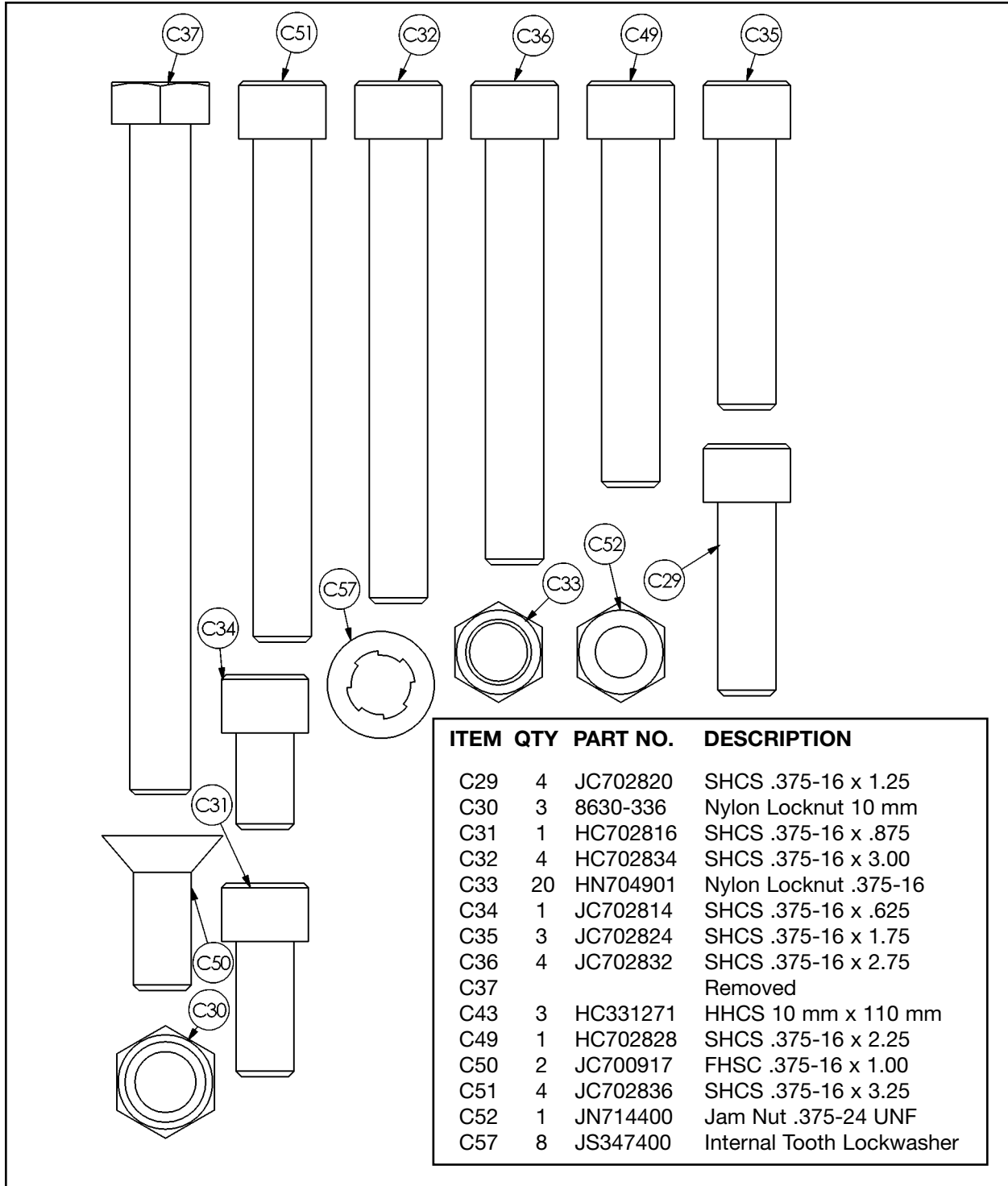

Figure 5

**3. Attach leg press frame to main frame assembly** (see steps 3A - 3C and Figure 6).

- A.** Locate connector (#C24), frame (#C14), two SHCS .375-16 x 2.75 (#C36), two SHCS .375-16 x 1.25 (#C29) and four nylon locknuts (#C33).
- B.** Attach connector (#C24) to frame (#C14). Tighten securely using two SHCS .375-16 x 2.75 (#C36) and two nylon locknuts (#C33).
- C.** Attach frame to column as shown in Figure 6, using two SHCS .375-16 x 1.25 (#C29) and two nylon locknuts (#C33).

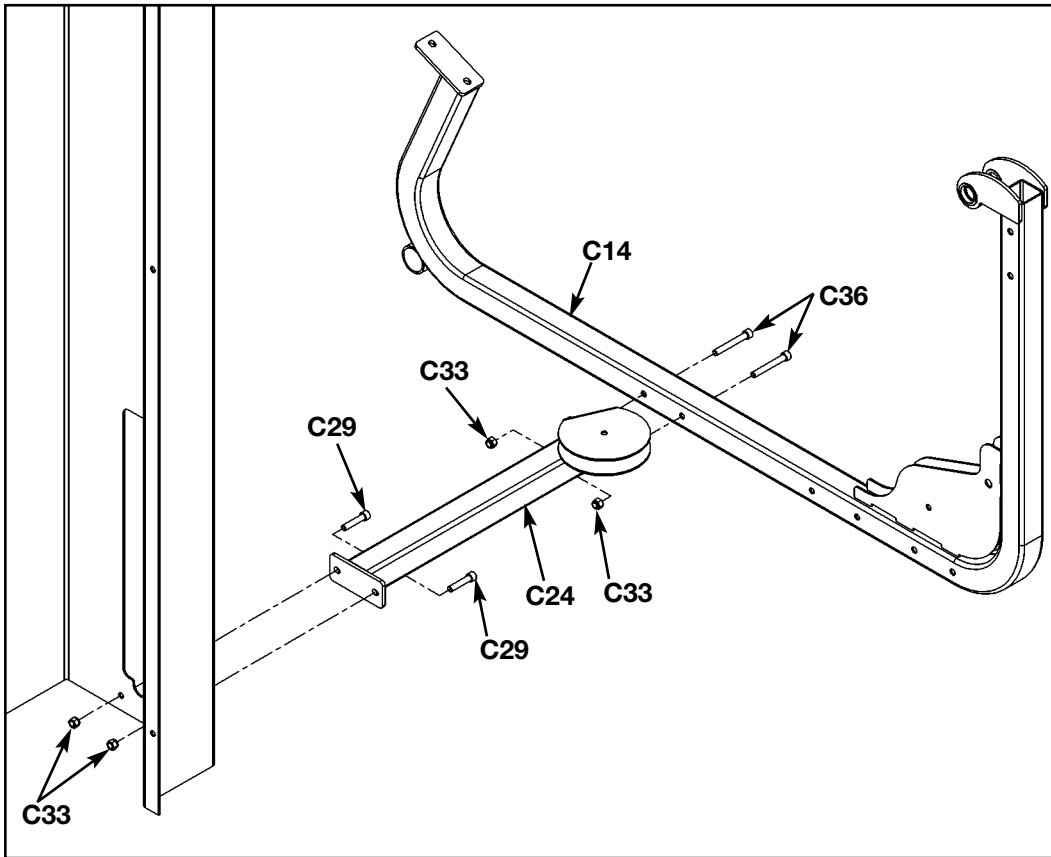

Figure 6

**4. Install roller tube** (see steps 4A - 4F, Figures 7 and 8).

**A.** Locate roller tube (#C19).

**B.** Set roller tube (#C19) on frame as shown in Figure 8. Do not install any hardware at this time. See Figure 7.

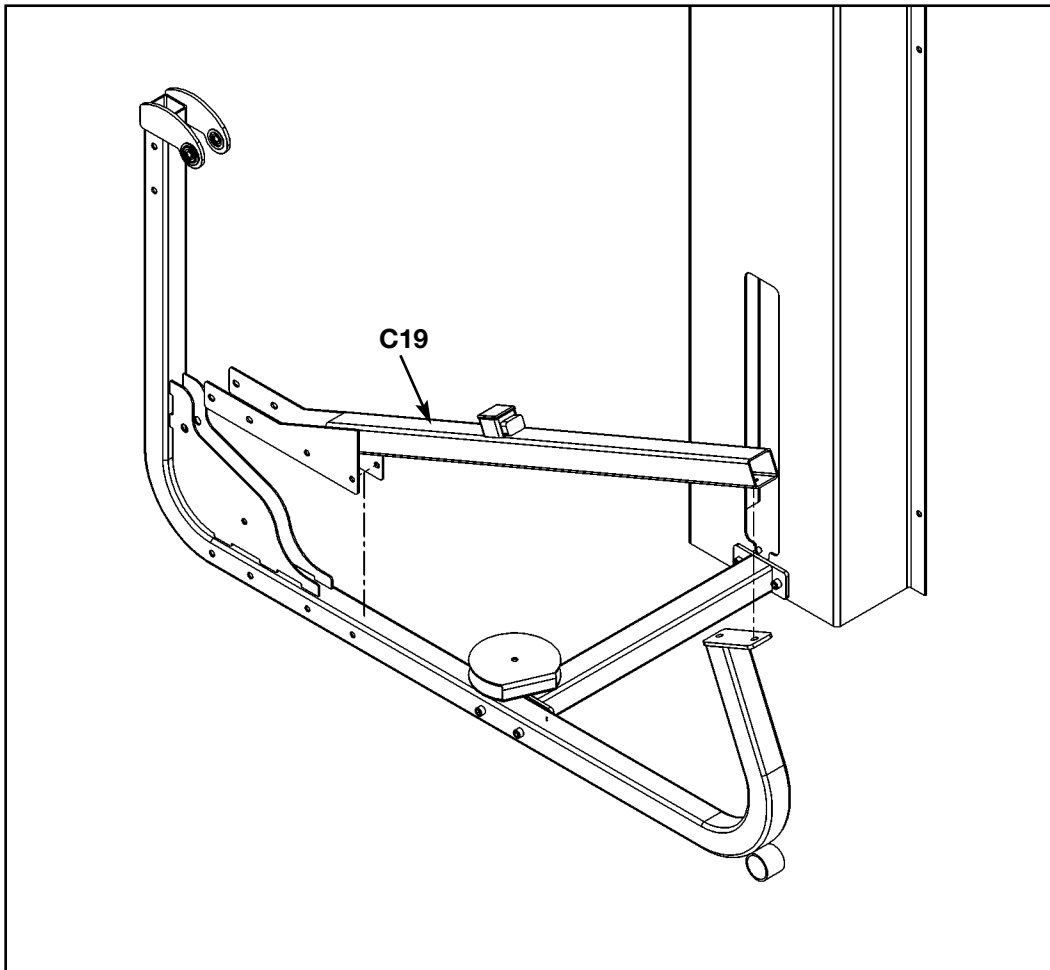

Figure 7

- C.** Locate roller plate (#C20), two rollers (#C26), two SHCS .375-16 x 2.75 (#C36), two HHCS 10 mm x 100 mm (#C43), two nylon locknuts 10 mm (#C30), two nylon locknuts .375-16 (#C33) and four internal tooth lockwashers (C57).
- D.** Slide roller plate (#C20) on roller tube (#C19) as shown in Figure 8. Be sure tabs are facing to the back and upward.
- E.** Install rollers (#C26) and secure roller plate (#C20) using two HHCS 10 mm x 100 mm (#C43), two nylon locknuts 10 mm (#C30) and four internal tooth lockwashers (C57). See Figure 8.
- F.** Install two SHCS .375-16 x 2.75 (#C36) and two nylon locknuts .375-16 (#C33) to secure roller tube. See Figure 8. Do not securely tighten hardware at this time.

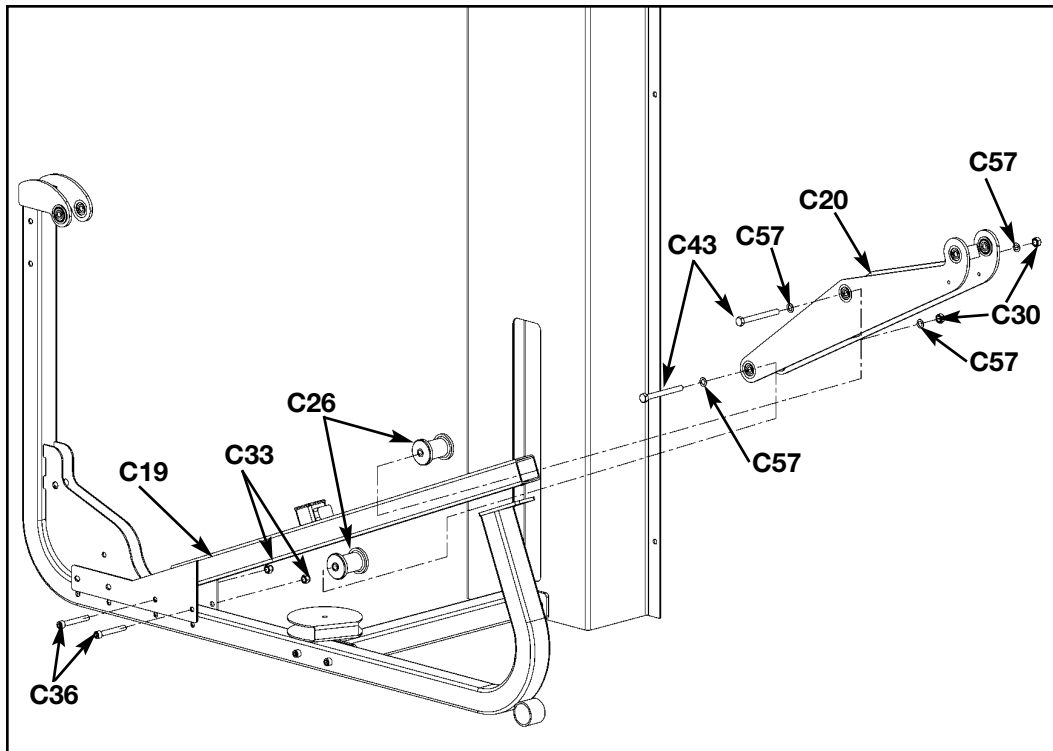

Figure 8

**5. Install footplates** (see steps 5A - 5D and Figure 9).

- A.** Locate right footplate (#C17), left footplate (#C18), one SHCS .375-16 x .875 (#C31), two SHCS .375-16 x 3.00 (#C32), two SHCS .375-16 x 3.25 (#C51) and five nylon locknuts .375-16 (#C33).
- B.** Install left (#C18) and right (#C17) footplates. Use two SHCS .375-16 x 3.00 (#C32) for the two upper holes and use two SHCS .375-16 x 3.25 (#C51) for the bottom two holes as shown in Figure 9.
- C.** Install SHCS .375-16 x .875 (#C31) and nylon locknut .375 (#C33) securing roller tube (#C19) as shown in Figure 9.
- D.** Securely tighten all hardware from steps 3 - 5.

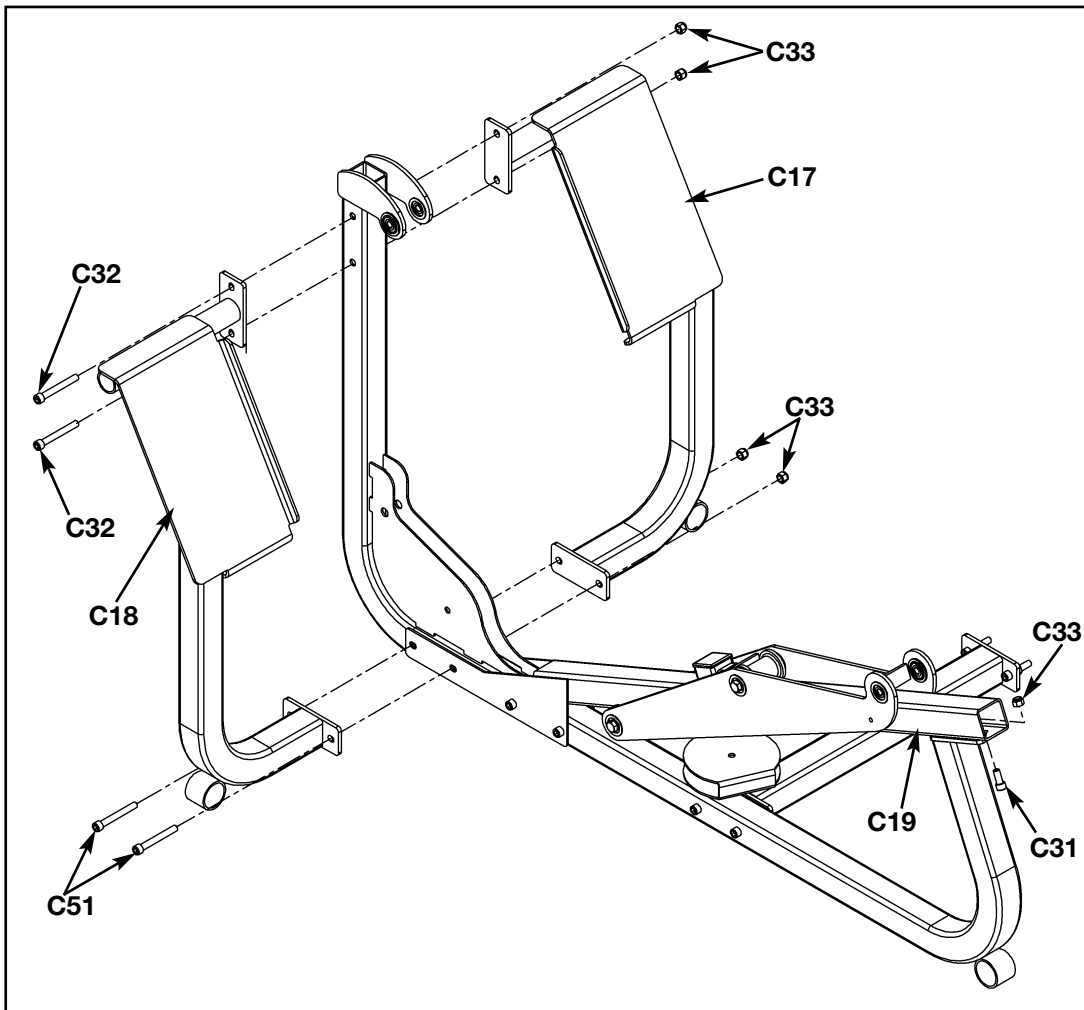

Figure 9

**6. Install pivot tube** (see steps 6A, 6B and Figure 10).

- A.** Locate pivot tube (#C23), one SHCS .375-16 x 3.25 (#C51) and one nylon locknut .375-16 (#C33).
- B.** Place pivot tube (#C23) on frame as shown below. Secure end by footplate with SHCS .375-16 x 3.25 (#C51) and nylon locknut (#C33). Do not tighten hardware at this time.

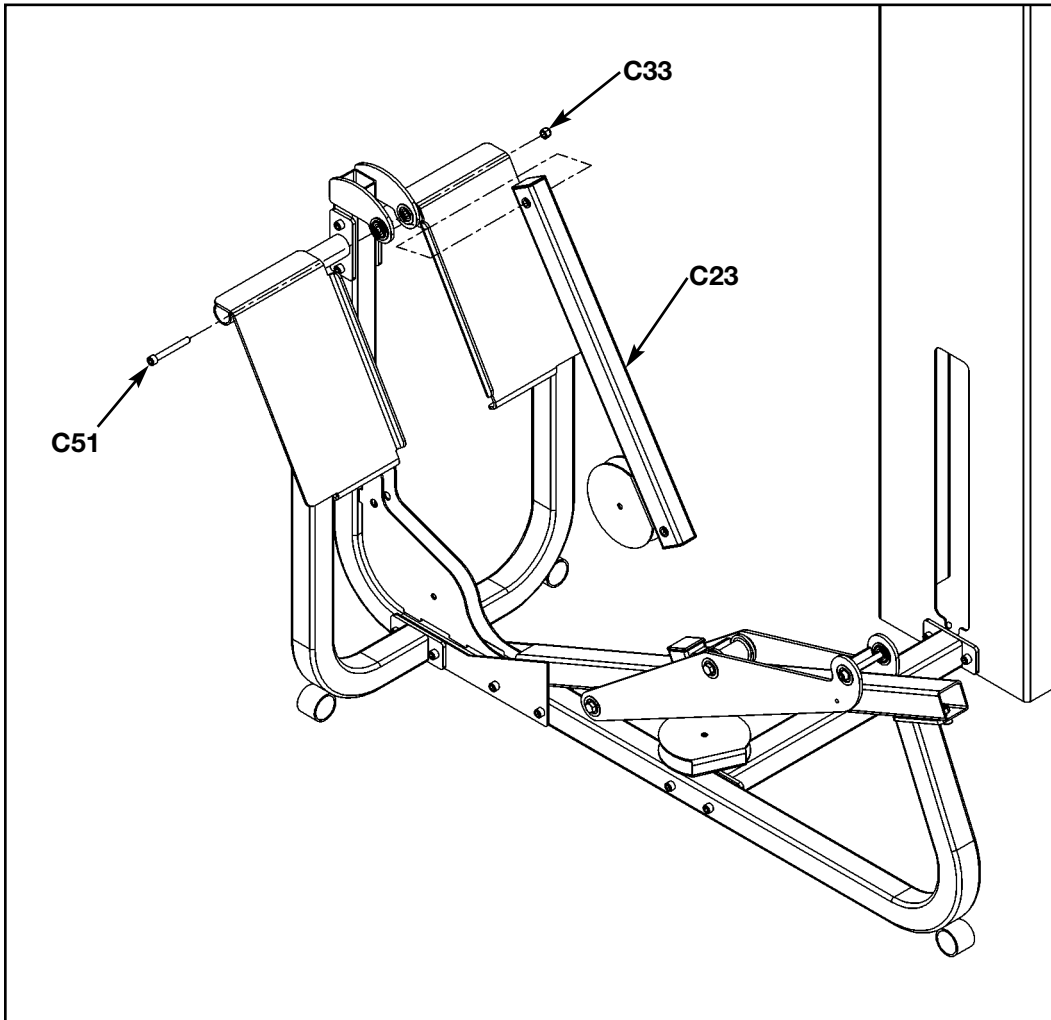

Figure 10

**7. Install seat frame** (see steps 7A - 7B and Figure 11).

- A.** Locate seat frame (#C15), one SHCS .375-16 x 3.25 (#C51), one HHCS 10 mm x 110 mm (#C43), one nylon locknut 10 mm (#C30), one nylon locknut .375-16 (#C33) and two internal tooth lockwashers (#C57).
- B.** Install seat frame (#C15) as shown in Figure 11 using one SHCS .375-16 x 3.25 (#C51), one nylon locknut .375-16 (#C33) and two internal tooth lockwashers (#C57) for the end connecting to the pivot tube. Use one HHCS 10 mm x 110 mm (#C43) to secure the other end of the seat frame.

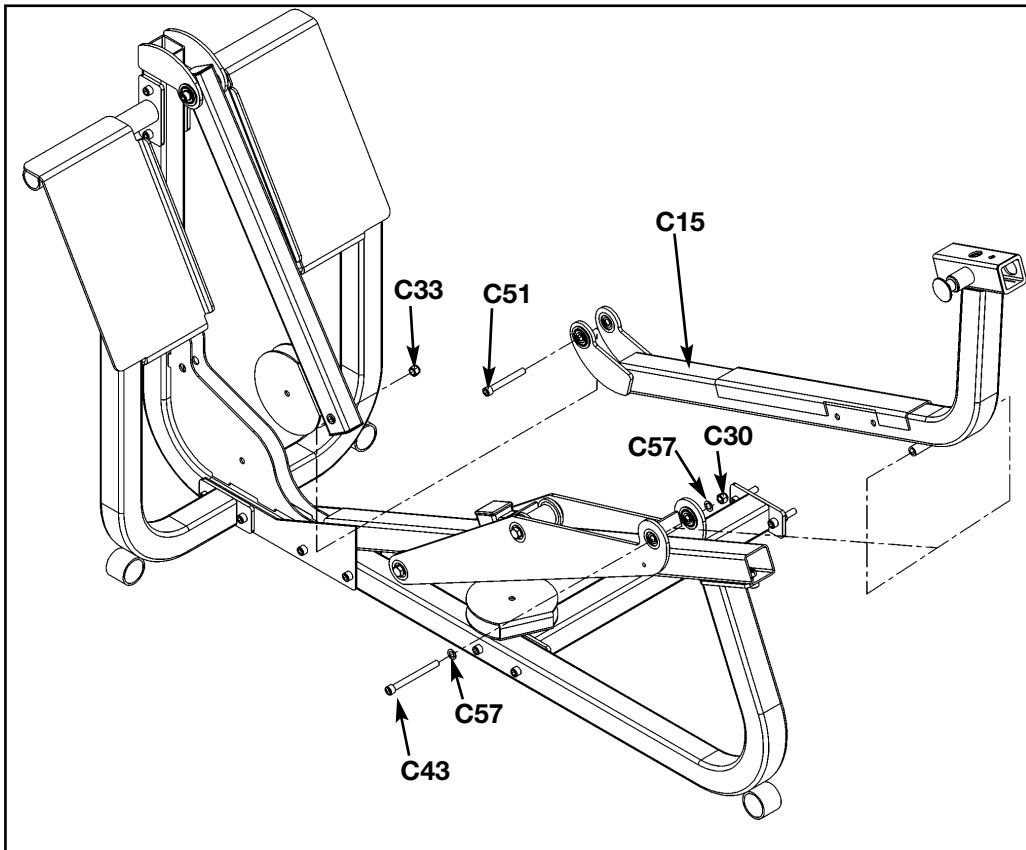

Figure 11

**8. Install handles** (see steps 8A, 8B and Figure 12).

- A.** Locate right handle (#C21), left handle (#C22), two SHCS .375-16 x 3.00 (#C32) and two nylon locknuts .375-16 (#C33).
- B.** Install right handle (#C21) and left handle (#C22) as shown in Figure 12, using two SHCS .375-16 x 3.00 (#C32) and two nylon locknuts (#C33). Securely tighten hardware from steps 6 - 8.

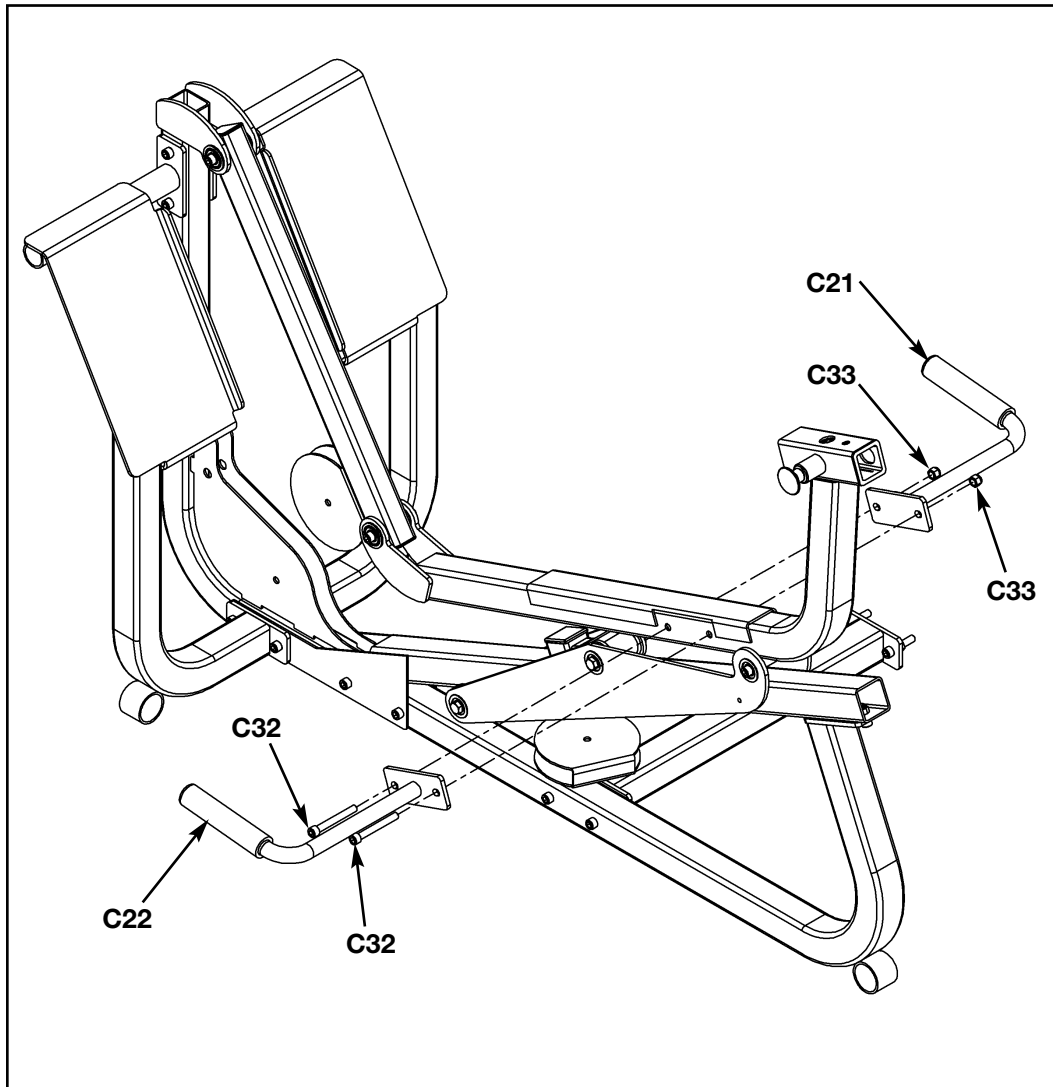

Figure 12

**9. Install cushions** (see steps 9A - 9I and Figures 13 - 16).

- A.** Locate seat tube (#C16), seat cushion (#C9), back cushion (#C6), two FHSCS .375-16 x 1.00 (#C50), two SHCS .375-16 x 1.25 (#C29) and two internal tooth lockwashers (#C57).
- B.** Install seat cushion (#C9) to seat tube (#C16) as shown in Figure 13 and secure using two FHSCS .375-16 x 1.00 (#C50).
- C.** Install back cushion (#C6) to seat tube (#C16) as shown in Figure 13, using two SHCS .375-16 x 1.25 (#C29) and two internal tooth lockwashers (#C57).

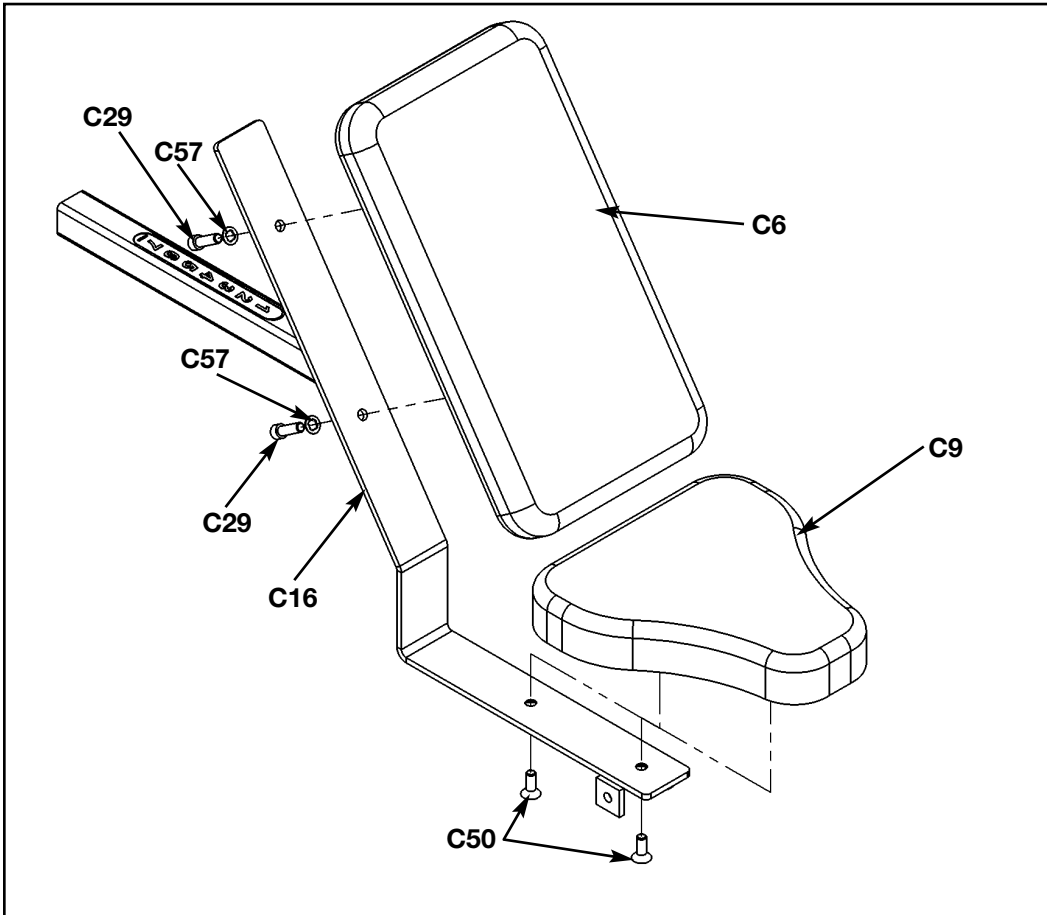

Figure 13

- D. Slide seat tube through seat frame as shown in Figure 14.

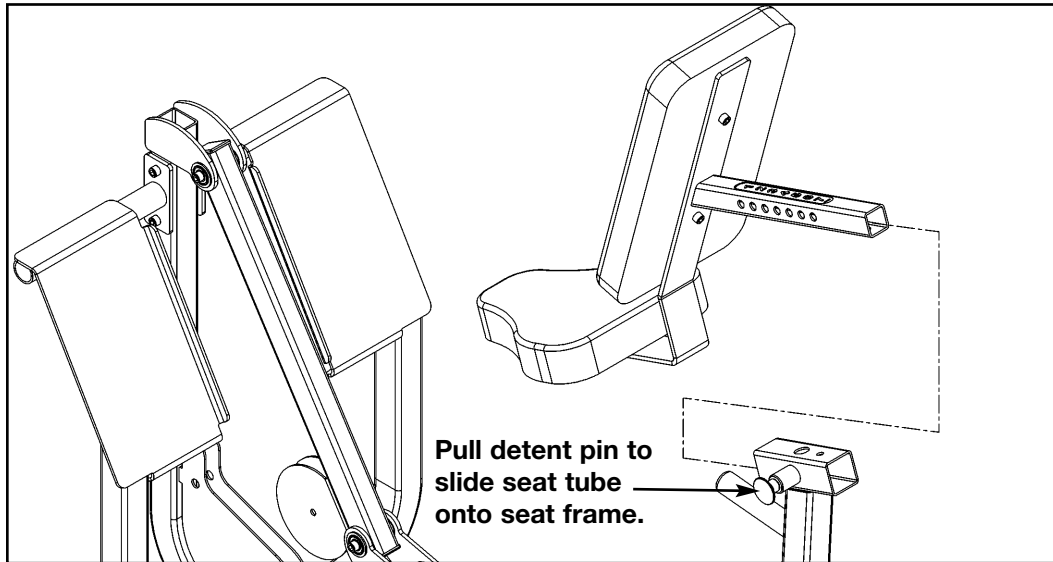

Figure 14

- E. Locate one SHCS .375-16 x .625 (#C34) and one nylon locknut .375-16 (#C33), one plastic insert (#C40) and one plastic insert (#C41).
- F. Secure with SHCS .375-16 x .625 (#C34) and nylon locknut (#C33) as shown in Figure 15. Securely tighten all hardware.
- G. Locate plastic insert (#C40) and plastic insert (#C41).
- H. Using a rubber mallet, install plastic insert (#C41) into seat tube (#C16) as shown in Figure 15.
- I. Using a rubber mallet, install plastic insert (#C40) into roller tube as shown in Figure 15.

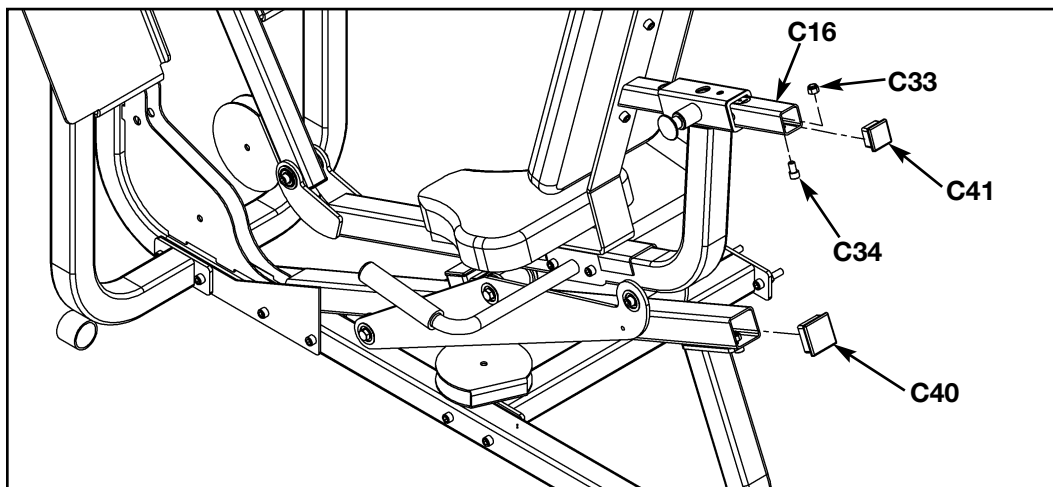

Figure 15

**10. Install weight stack cable** (see steps 10A - 10J and Figure 16).

From the Leg Press Station hardware pack, locate cable (#C46), three pulleys (#C1), three SHCS .375-16 x 1.75 (#C35), one SHCS .375-16 x 2.25 (#C49), four nylon locknuts .375 (#C33) two cable guards (#C10), one jam nut .375-24 (#C52), one rod end bearing (#C48), and two spacers (#C47). From the main frame hardware pack, locate two pulleys (#E1), two SHCS .375-16 x 1.75 (#E39) and two nylon locknuts .375 (#E34).

- A. Thread jam nut (#C52) half way on threaded end of cable (#C46).
- B. Thread rod end bearing (#C48) up to jam nut (#C52) and install rod end bearing (#C48) using one SHCS .375-16 x 2.25 (#C49) two spacers (#C47) and one nylon locknut (#C33). See Figure 16, letter B.
- C. Slide cable (#C48) through cable guard (#C10) and install first pulley (#C1) and route cable (#C48) using hardware shown in Figure 16, letter C.
- D. Install second pulley (#C1) and route cable (#C48) using hardware shown in Figure 16, letter D.
- E. Slide cable (#C48) through cable guard (#C10) and install third pulley (#C1) using hardware shown in Figure 16, letter E.
- F. Route cable (#C48) and install fourth pulley (#E1) using hardware shown in Figure 16, letter F.
- G. Route cable (#C48) and install fifth pulley (#E1) using hardware shown in Figure 16, letter G.
- H. Route cable (#C48) down to weight stack. Slide rubber boot (#E3) on cable.
- I. Drive spiral pin (#E35) through top weight connector and cable. Top weight should be just resting on second weight.
- J. Slide rubber boot (#E3) over step of top weight.

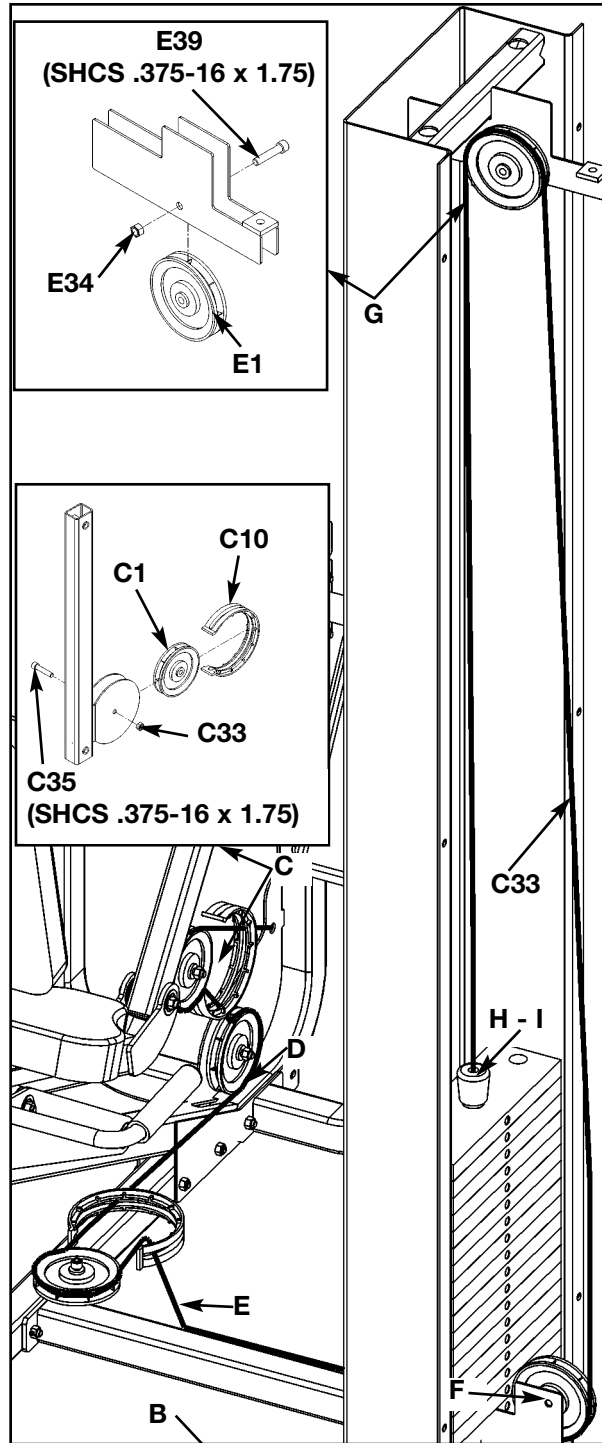
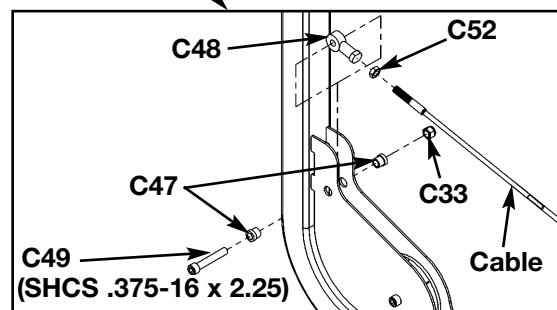
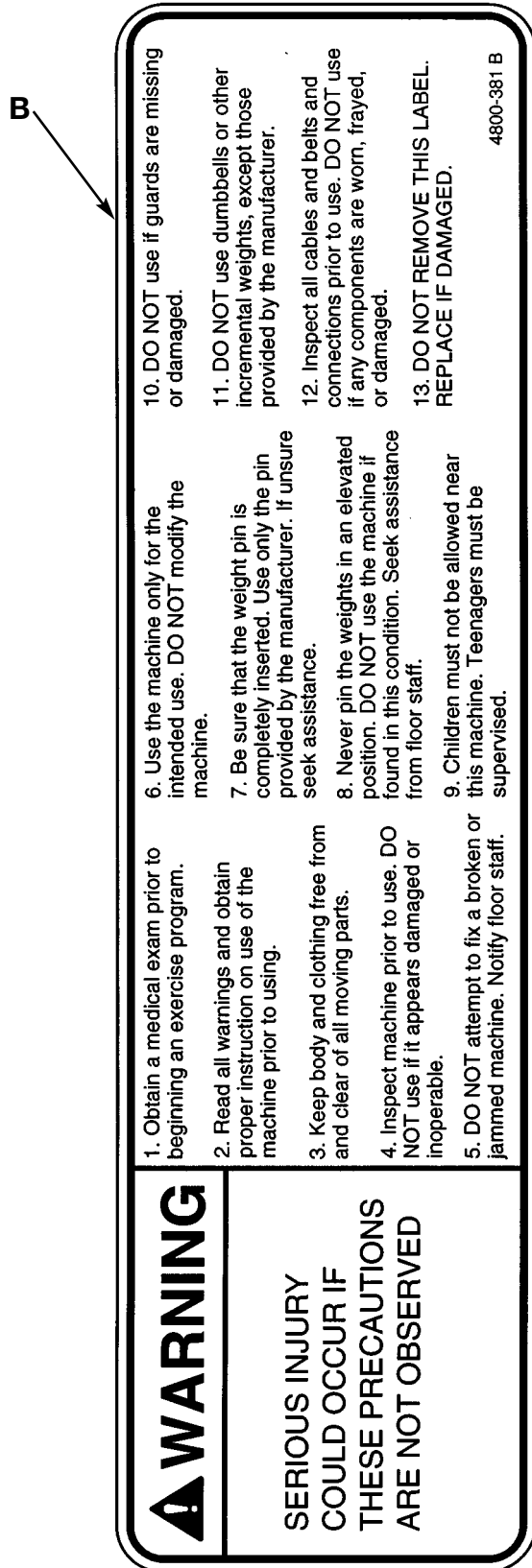

Figure 16



***This page intentionally left blank***  
***(this allows step 11 and Figure 17 to be located on facing pages)***

11. Verify warning decals are present and not damaged (see decals below and Figure 17).



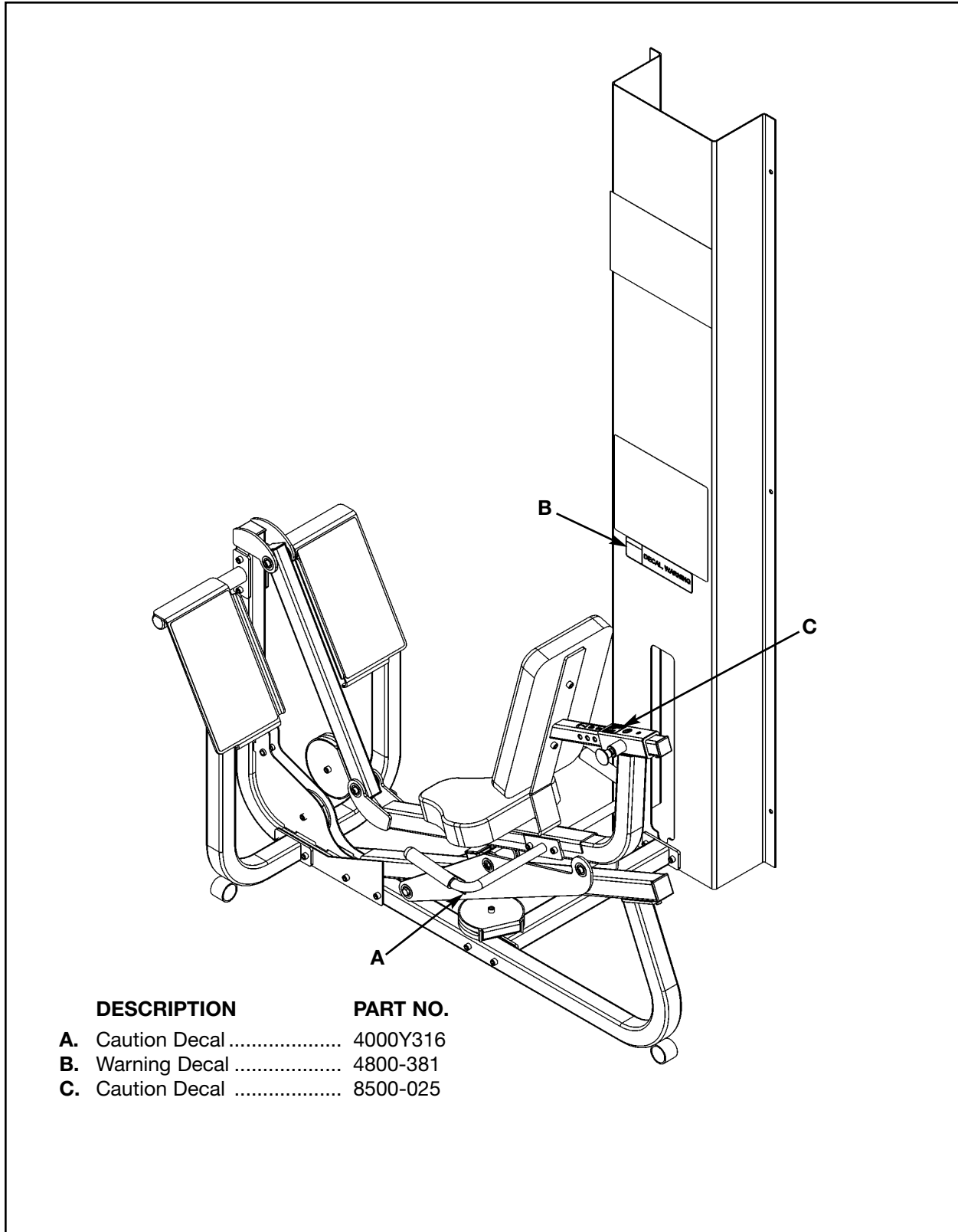

| DESCRIPTION            | PART NO. |
|------------------------|----------|
| A. Caution Decal ..... | 4000Y316 |
| B. Warning Decal ..... | 4800-381 |
| C. Caution Decal ..... | 8500-025 |

Figure 17

Leg Press Exploded-View Diagram (for assembly only)

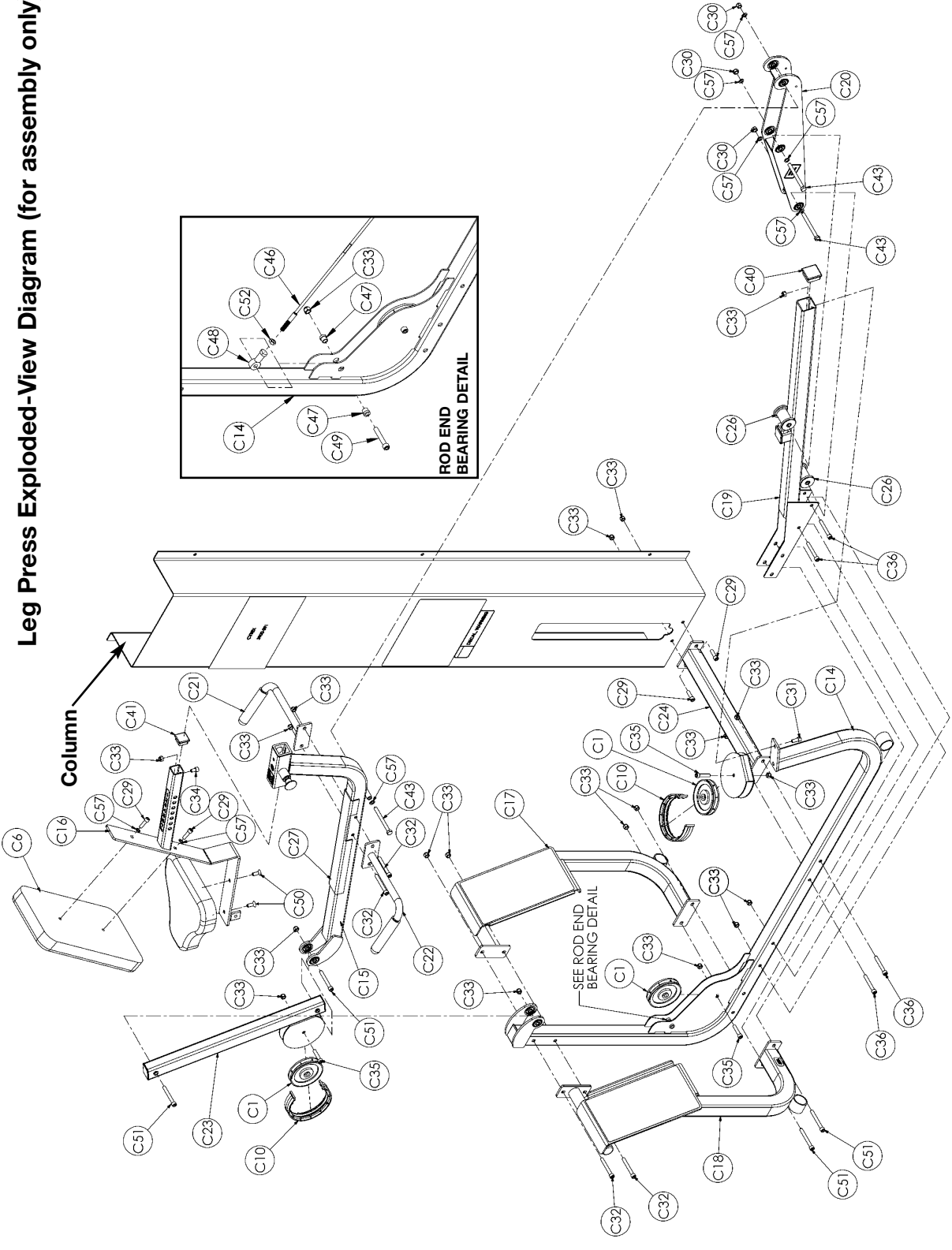

**Leg Press Station Parts List (not all parts are listed such as pulleys for inside). See Chapter 8 for a complete parts listing.**

| ITEM | QTY | PART NO.   | DESCRIPTION         |
|------|-----|------------|---------------------|
| C1   | 3   | 08014      | Pulley              |
| C6   | 1   | 4106S055-0 | Back Cushion        |
| C9   | 1   | 4800-026   | Seat Cushion        |
| C10  | 2   | 4800-570   | Cable Guard         |
| C14  | 1   | 8630-200   | Frame               |
| C15  | 1   | 8630-201   | Seat Frame          |
| C16  | 1   | 8630-202   | Seat Tube           |
| C17  | 1   | 8630-203   | Right Foot Plate    |
| C18  | 1   | 8630-204   | Left Foot Plate     |
| C19  | 1   | 8630-205   | Roller Tube         |
| C20  | 1   | 8630-206   | Roller Plate        |
| C21  | 1   | 8630-207   | Right Handle        |
| C22  | 1   | 8630-208   | Left Handle         |
| C23  | 1   | 8630-209   | Pivot Tube          |
| C24  | 1   | 8630-210   | Connector           |
| C26  | 2   | 8630-322   | Roller              |
| C27  | 1   | 8630-326   | Seat Sleeve         |
| C28  | 2   | 8630-331   | Spacer              |
| C29  | 4   | JC702820   | SHCS .375-16 x 1.25 |

| ITEM | QTY | PART NO. | DESCRIPTION                      |
|------|-----|----------|----------------------------------|
| C30  | 3   | 8630-336 | Nylon Locknut 10 mm              |
| C31  | 1   | HC702816 | SHCS .375-16 x .875              |
| C32  | 4   | HC702834 | SHCS .375-16 x 3.00              |
| C33  | 20  | HN704901 | Locknut .375-16                  |
| C34  | 1   | JC702814 | SHCS .375-16 x .625              |
| C35  | 3   | JC702824 | SHCS .375-16 x 1.75              |
| C36  | 4   | JC702832 | SHCS .375-16 x 2.75              |
| C37  |     |          | Removed                          |
| C40  | 1   | PP090210 | Plastic Insert 2.00 Sq x 10-14 G |
| C41  | 1   | PP090211 | Plastic Insert 2.00 Sq x 10-14 G |
| C43  | 3   | HC331271 | HHCS 10 mm x 110 mm              |
| C47  | 2   | 8630-340 | Spacer                           |
| C48  | 1   | FB030213 | Rod End Bearing                  |
| C49  | 1   | HC702828 | SHCS .375-16 x 2.25              |
| C50  | 2   | JC700917 | FHSCS .375-16 x 1.00             |
| C51  | 4   | JC702836 | SHCS .375-16 x 3.25              |
| C52  | 1   | JN714400 | Jam Nut .375-24                  |
| C57  | 8   | JS347400 | Internal Tooth Lockwasher        |

***This page intentionally left blank***

**Pressing Station Diagram**

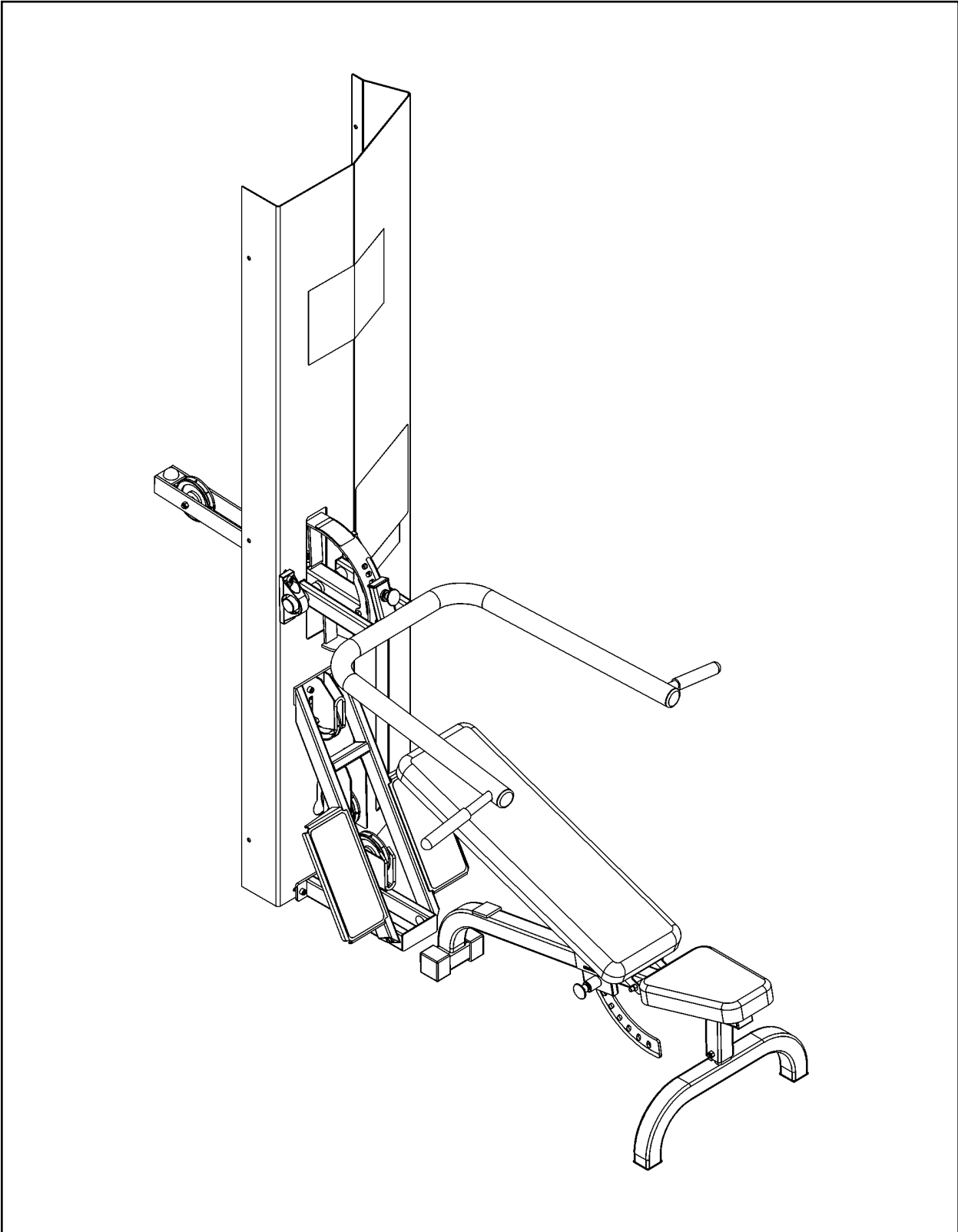

**Pressing Station Assembly**

1. **Verify contents of the Pressing Station boxes** (see steps 1A - 1C and Figures 1-3).
  - A. Locate the Pressing Station box (containing the frame).
  - B. Locate the Pressing Station cushion box (removed from the main frame assembly).
  - C. Verify contents of both boxes. See Figures 1-3.

| ITEM | QTY | PART NO. | DESCRIPTION           |
|------|-----|----------|-----------------------|
| A8   | 1   | 4800-019 | Seat Cushion          |
| A9   | 1   | 4800-009 | Back Cushion          |
| A16  | 1   | 8610-308 | Shaft                 |
| A17  | 1   | 8610-203 | Brace                 |
| A18  | 1   | 8610-204 | Platform              |
| A19  | 1   | 8610-201 | Pressing Arm          |
| A20  | 1   | 8610-207 | Leg                   |
| A21  | 1   | 8610-210 | Bench Frame           |
| A22  | 1   | 8610-205 | Swivel Pulley Bracket |
| A23  | 1   | 8510-208 | Cushion Plate         |
| A24  | 1   | 8610-202 | Pivot Arm             |
| A25  | 1   | 8510-210 | Detent Plate          |
| A49  | 1   | 8610-002 | Cable 179.25 Long     |
| A50  | 1   | 8610-003 | Cable 173.44 Long     |
| A55  | 1   | 51122    | Ankle Strap           |
| A56  | 2   | 5310S040 | Handle Sub-Assembly   |
| A57  | 1   | 02204    | EZ Curl Handle        |
|      | 1   |          | Hardware Pack         |

Figure 1

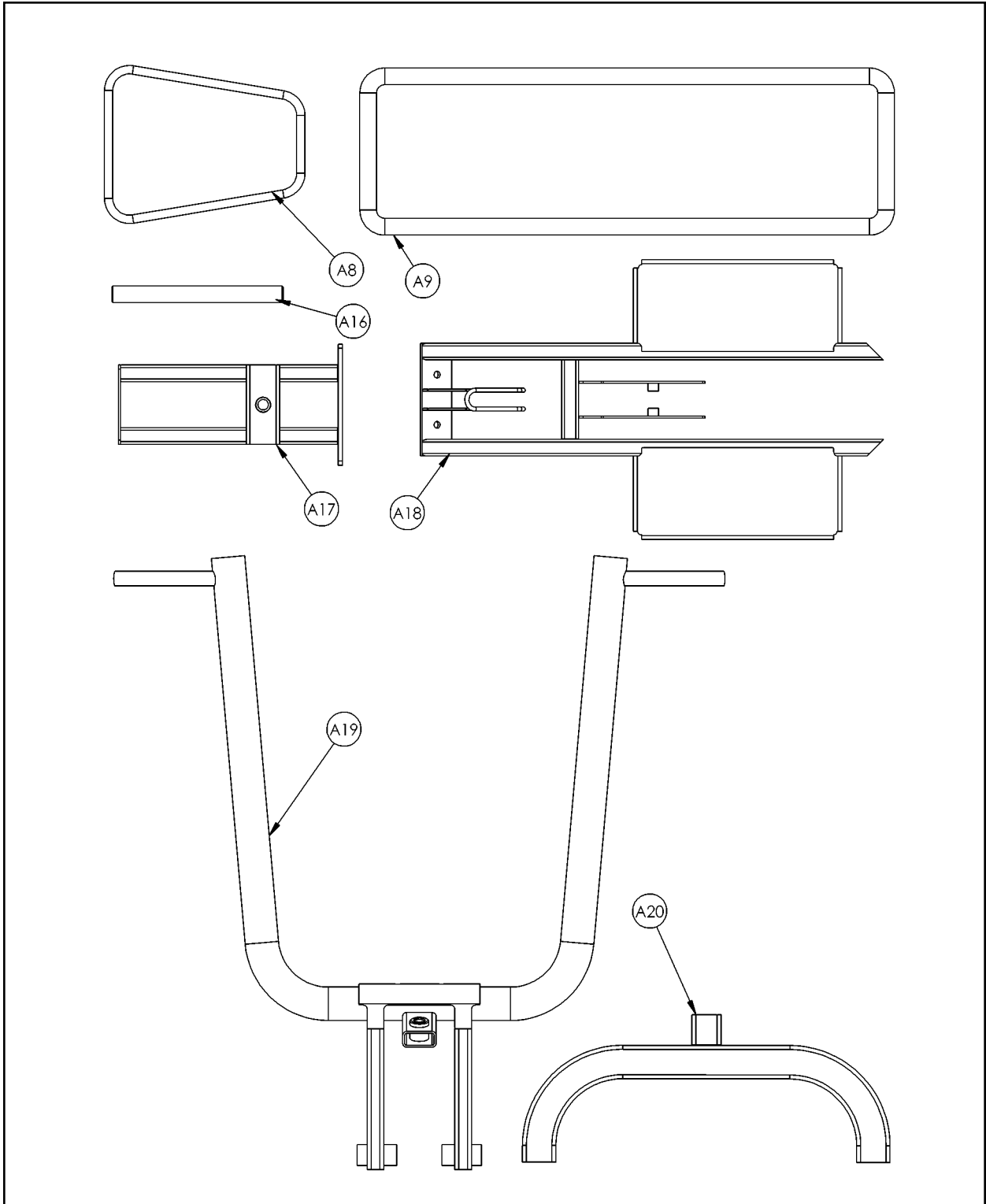

Figure 2

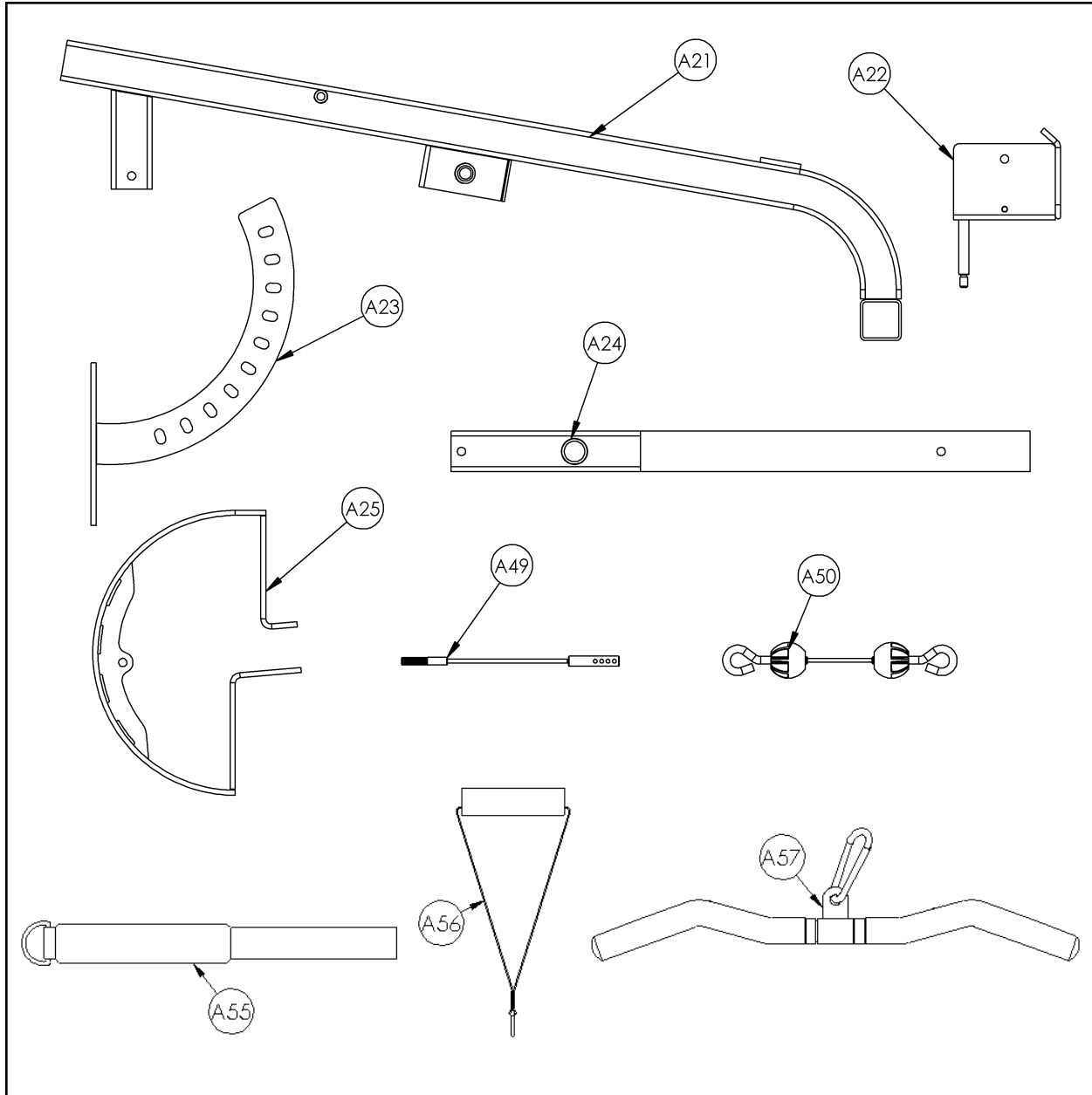
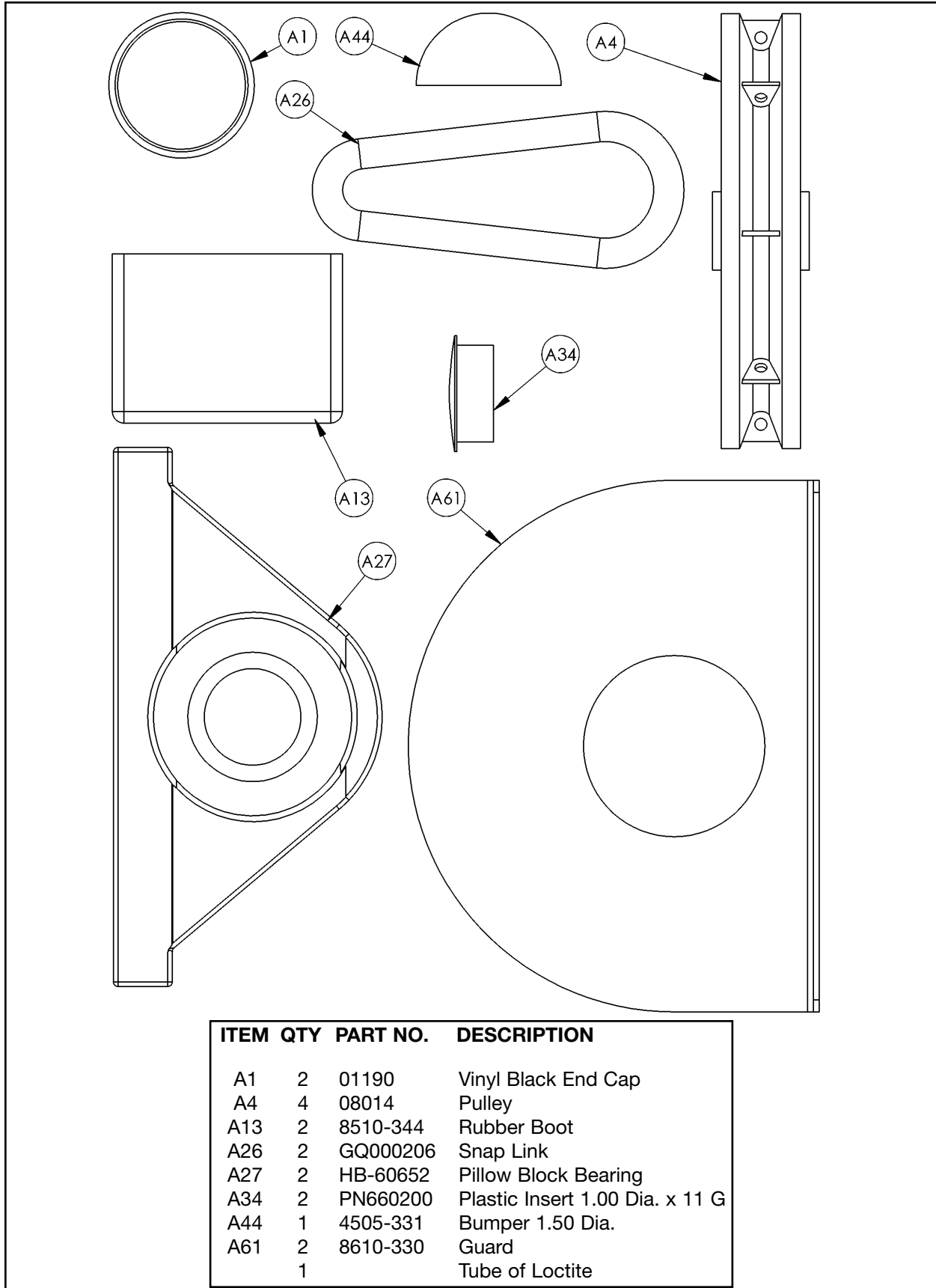

Figure 3

**2. Verify contents of the Pressing Station hardware pack (see steps 2A, 2B, Figures 4 and 5).**

**A.** Locate hardware pack.

**B.** Verify contents of hardware pack. If desired, sort out hardware into different containers. Do not combine hardware with other hardware packs. See Figures 4 and 5 for contents of hardware pack.



| ITEM | QTY | PART NO. | DESCRIPTION                     |
|------|-----|----------|---------------------------------|
| A1   | 2   | 01190    | Vinyl Black End Cap             |
| A4   | 4   | 08014    | Pulley                          |
| A13  | 2   | 8510-344 | Rubber Boot                     |
| A26  | 2   | GQ000206 | Snap Link                       |
| A27  | 2   | HB-60652 | Pillow Block Bearing            |
| A34  | 2   | PN660200 | Plastic Insert 1.00 Dia. x 11 G |
| A44  | 1   | 4505-331 | Bumper 1.50 Dia.                |
| A61  | 2   | 8610-330 | Guard                           |
|      | 1   |          | Tube of Loctite                 |

Figure 4

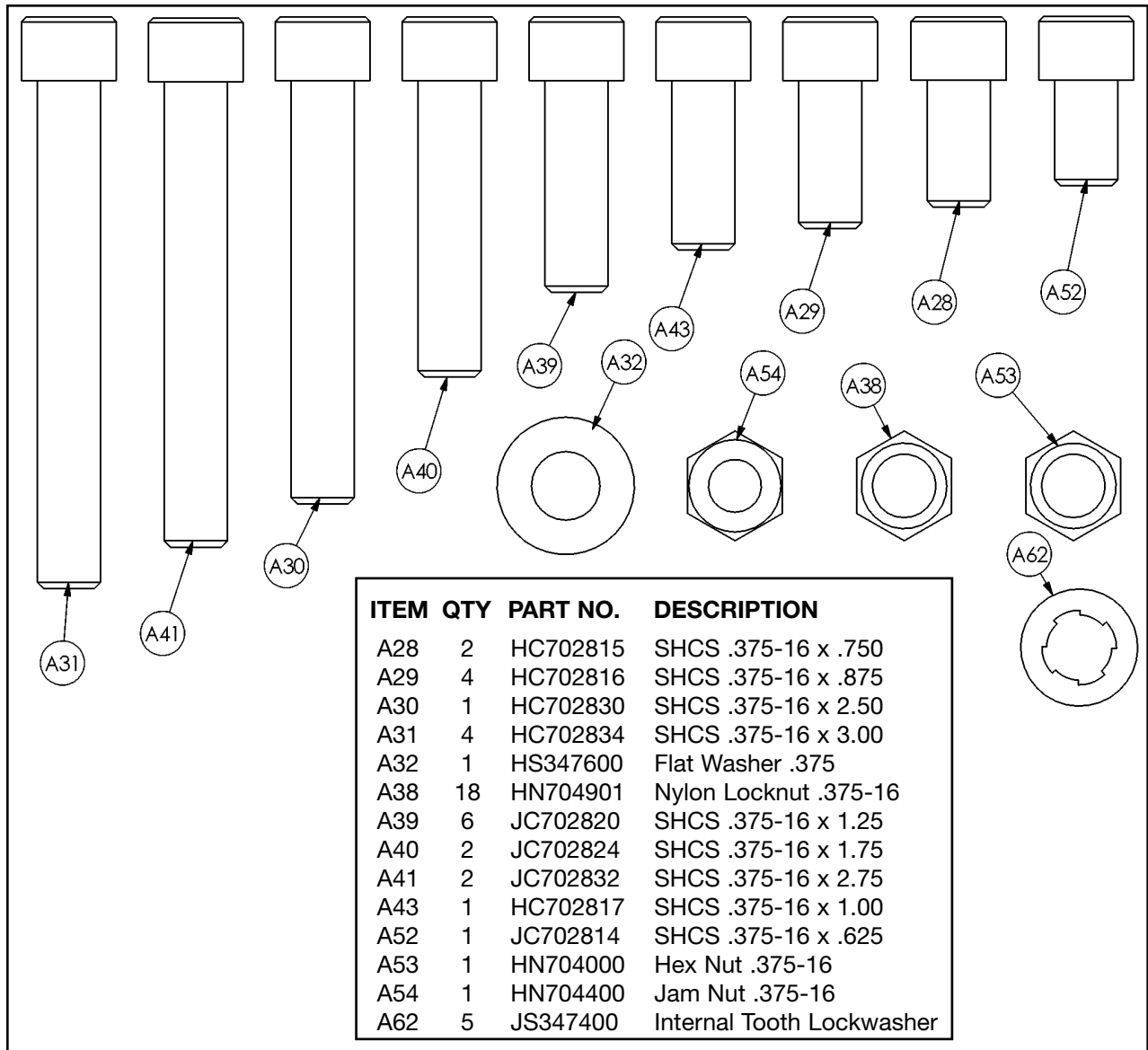

Figure 5

**3. Assemble the Pressing Station Bench** (see steps 3A - 3N, Figures 6 - 8).

- A.** Locate bench frame (#A21), leg (#A20), one SHCS .375-16 x 2.50 (#A30), one nylon locknut .375-16 (#A38) and two rubber caps (#A13).
- B.** Attach leg (#A20) to bench (#A21) using one SHCS .375-16 x 2.50 (#A30) and one nylon locknut (#A38). See Figure 6.
- C.** Attach two rubber caps (#A13) to bench frame (#A21) using a rubber mallet. See Figure 6.

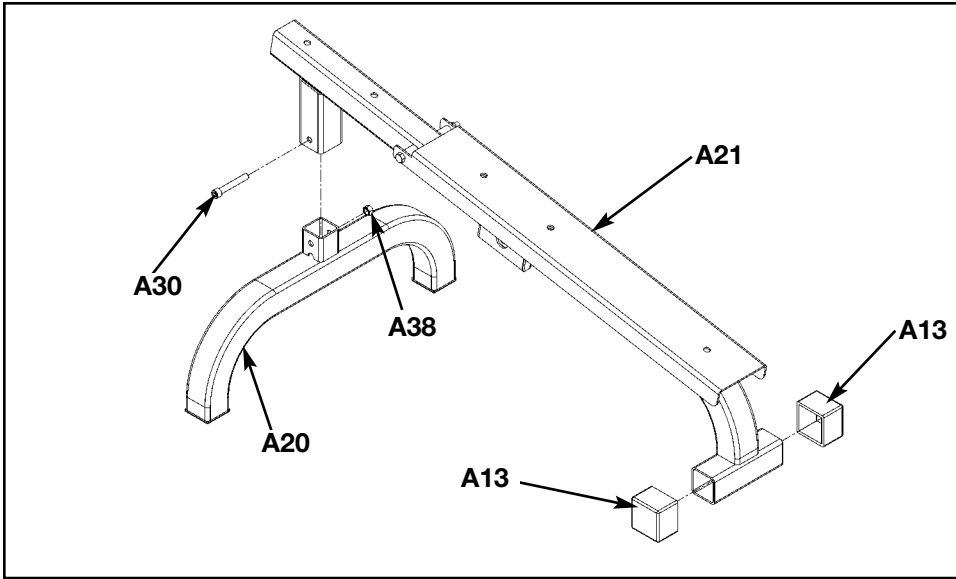

Figure 6

- D.** Locate the back cushion (#A9), cushion plate (#A23), one SHCS .375-16 x 1.00 (#A43), two SHCS .375-16 x 1.25 (#A39) and three internal tooth lockwashers (#A62).
- E.** Carefully raise the back plate.
- F.** Insert cushion plate adjustment bar (#A23) into hole in bench as shown in Figure 7.
- G.** Place back cushion (#A9) onto back plate (#A23) and align holes.
- H.** Insert two SHCS .375-16 x 1.25 (#A39) and two internal tooth lockwashers (#A62) as shown in Figure 5, securing the back cushion and cushion plate to the back plate. Do not tighten screws at this time.
- I.** Insert one SHCS .375-16 x 1.00 (#A43) and one internal tooth lockwasher (#A62) through cushion plate and back cushion (in the top hole) as shown in Figure 7.
- J.** Securely tighten all three screws from steps H and I.

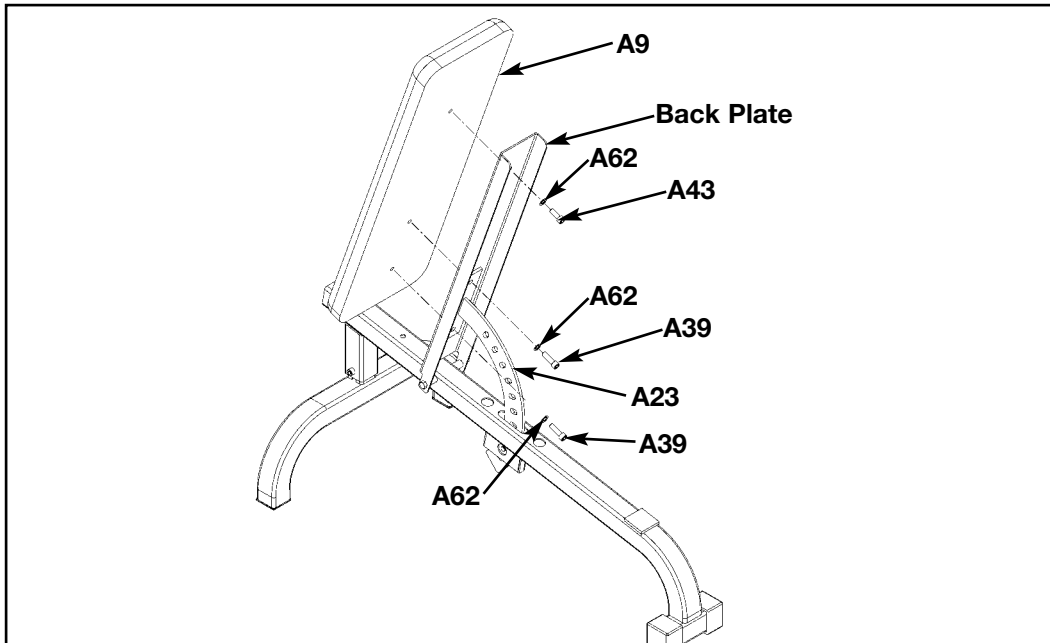

Figure 7

- K.** Locate seat cushion (#A8), two SHCS .375-16 x 3.00 (#A31) and two internal tooth lockwashers (#A62).
- L.** Raise back cushion to the fifth position.
- M.** Install seat cushion to the bench using two SHCS .375-16 x 3.00 (#A31) and two internal tooth lockwashers (#A62) as shown in Figure 8.

**Note:** *Place seat cushion so that that the wider end faces toward the back cushion.*

- N.** Lower back cushion and set bench aside.

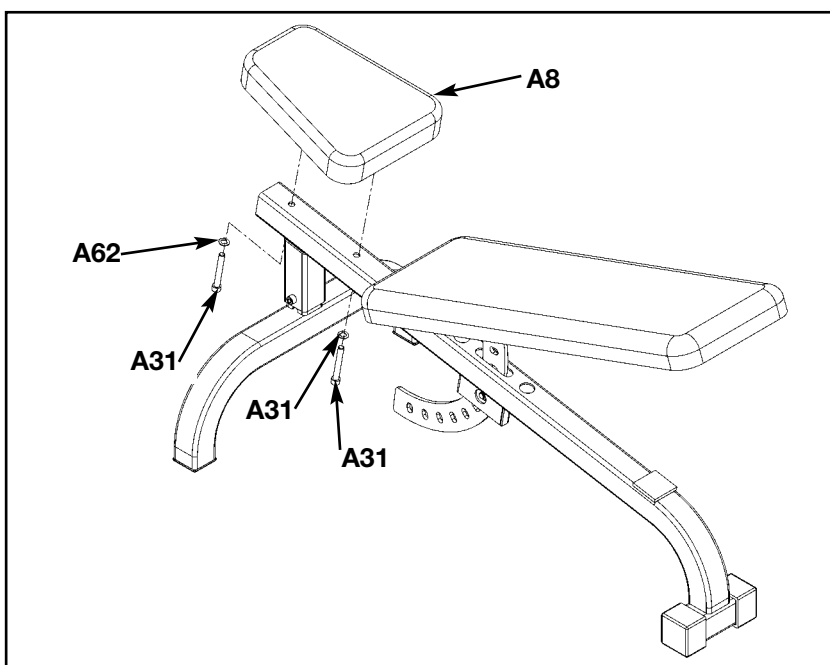

Figure 8

4. Install brace to the pressing station column (see steps 4A - 4E and Figure 9).
- A. Locate brace (#A17), swivel pulley bracket (#A22), one flat washer .375 (#A32), three nylon locknuts (#A38) and two SHCS .375-16 x .875 (#A29).
  - B. Insert swivel pulley bracket (#A22) into brace (#A17) as shown in Figure 9.
  - C. Attach flat washer (#A32) and nylon locknut (#A38). Tighten securely.
  - D. Turn swivel pulley bracket (#A22) so that it is facing away from the column as shown in Figure 9.
  - E. Attach brace (#A17) to column using two SHCS .375-16 x .875 (#A29) and two nylon locknuts (#A38). **NOTE:** Do not securely tighten screws at this time. See Figure 9.

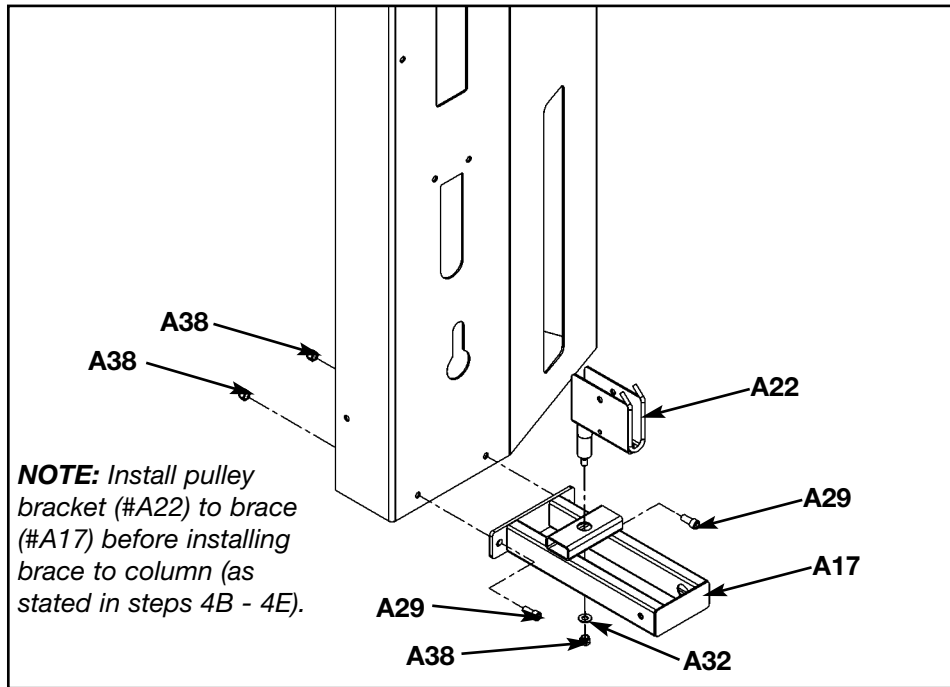

Figure 9

**5. Install platform to column** (see steps 5A - 5E and Figure 10).

- A.** Locate platform (#A18), two SHCS .375-16 x .875 (#A29), two SHCS .375-16 x .750 (#A28), four nylon locknuts (#A38) and two plastic inserts 1.00 Dia. x 11 G (#A34).
- B.** Attach upper end of platform (#A18) to column using two SHCS .375-16 x .875 (#A29) and two nylon locknuts (#A38). See Figure 10. **NOTE:** Do not securely tighten screws at this time.
- C.** Attach lower end of platform (#A18) to brace (#A17) using two SHCS .375-16 x .750 (#A28) and two nylon locknuts (#A38). **NOTE:** Place SHCS (#A28) on Allen wrench then place through hole in brace (#A17).
- D.** Securely tighten all hardware installed in steps 5B and 5C.
- E.** Install two plastic inserts 1.00 Dia. (#A34) as shown in Figure 10.

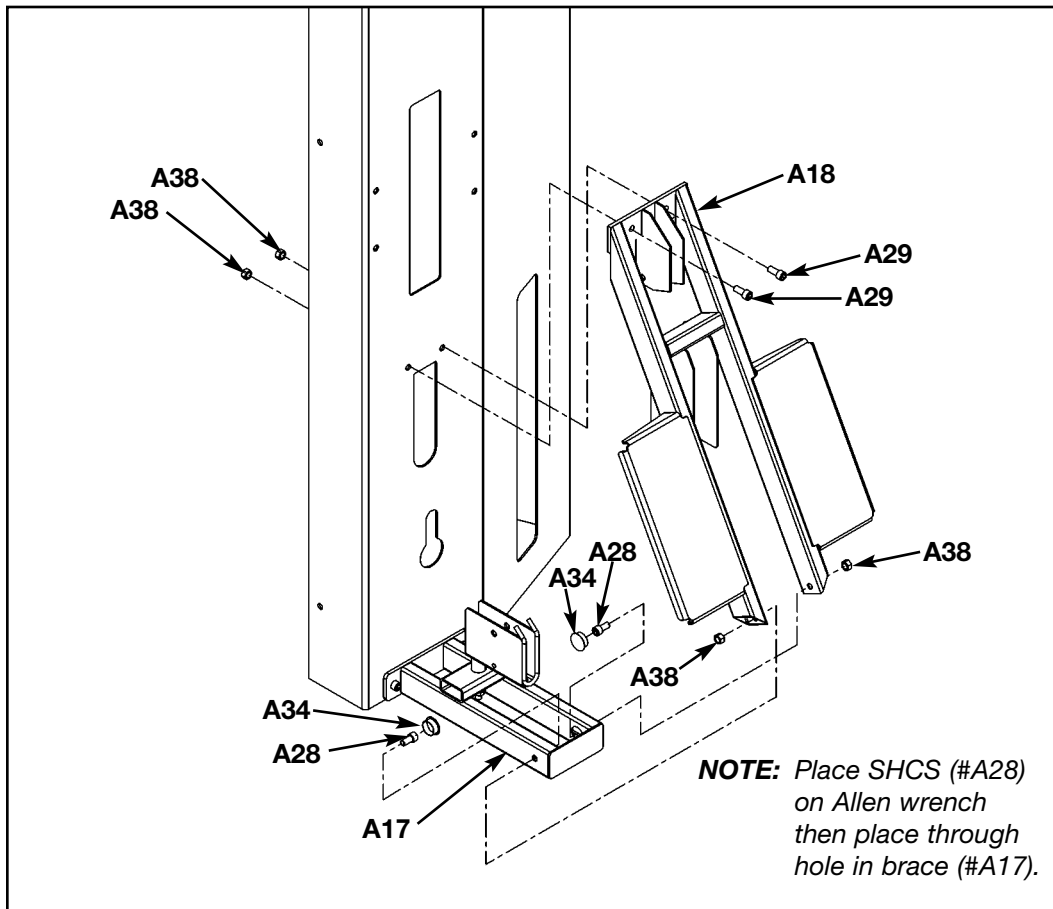

Figure 10

6. Install pressing arm (see steps 6A - 6K, Figures 11 - 13).

- A. Locate detent plate (#A25), pivot arm (#A24), two pillow block bearings (#A27), pressing arm (#A19), shaft (#A16), two vinyl end caps (#A1), one SHCS .375-16 x 3.00 (#A31), one SHCS .375-16 x 2.75 (#A41), four SHCS .375-16 x 1.25 (#A39), six nylon locknuts (#A38), one SHCS .375-16 x .625 (#A52), one bumper (#A44) and two guards (#A61).
- B. Attach detent plate (#A25) to pivot arm (#A24) as shown in Figure 11 (warning decal faces upward), using SHCS .375-16 x 3.00 (#A31), SHCS .375-16 x 2.75 (#A41) and two nylon locknuts (#A38).
- C. Install bumper (#A44) with SHCS .375-16 x .625 (#A52).

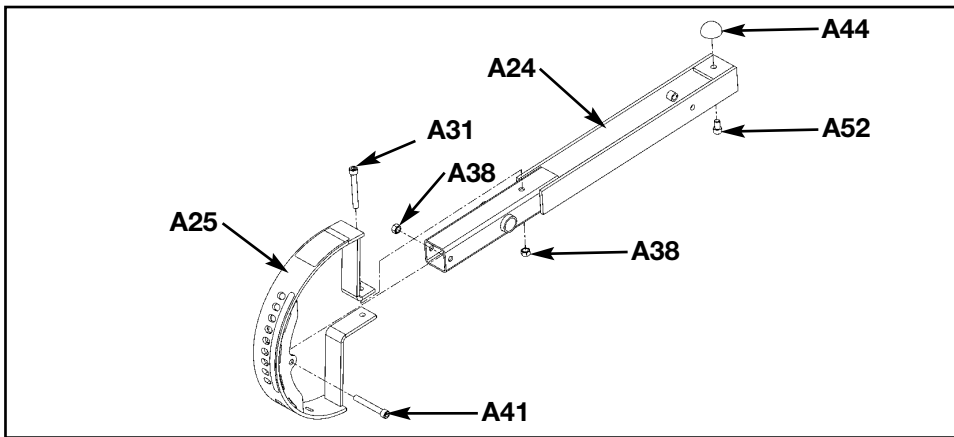

Figure 11

- D. Install pillow block bearings (#A27) and guards (#A61) as shown in Figure 12 using four SHCS .375-16 x 1.25 (#A39) and four nylon locknuts (#A38). Be sure set screws (on pillow blocks) are located on the outside. **NOTE:** Do not securely tighten screws (#A39) at this time.

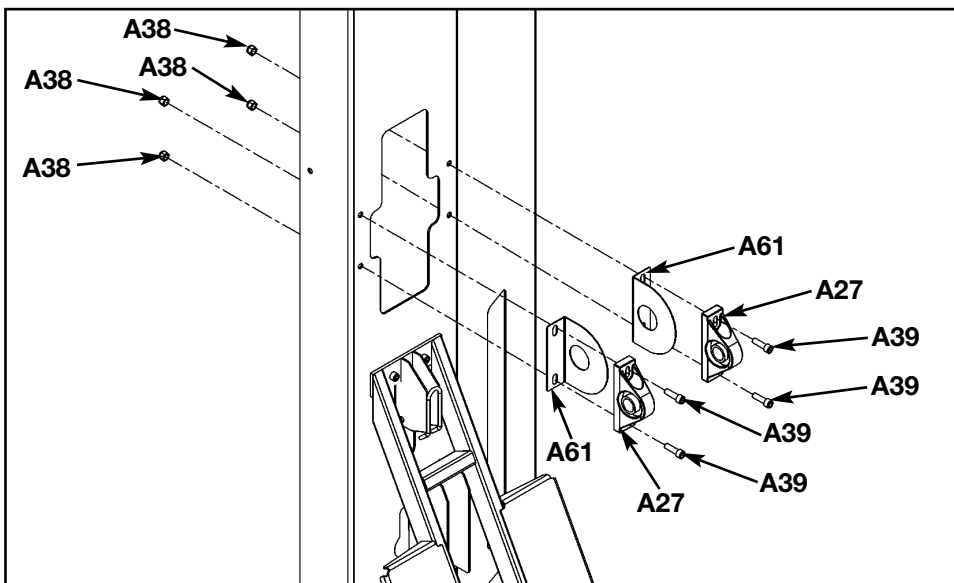

Figure 12

- E. Verify set screws are loose in pillow block bearings.
- F. With an assistant, carefully place pivot arm (#A24) detent plate (#A25) through slot in column, then align pressing arm (#A19) into place and slide shaft (#A16) through pillow block bearing, pressing arm, pivot arm and to the other side through pivot arm, pressing arm and pillow block bearing. See Figure 13.

**! WARNING:** *Arm will drop when detent pin is pulled out. Be sure detent pin is fully engaged during assembly. Failure to do so could result in personal injury.*

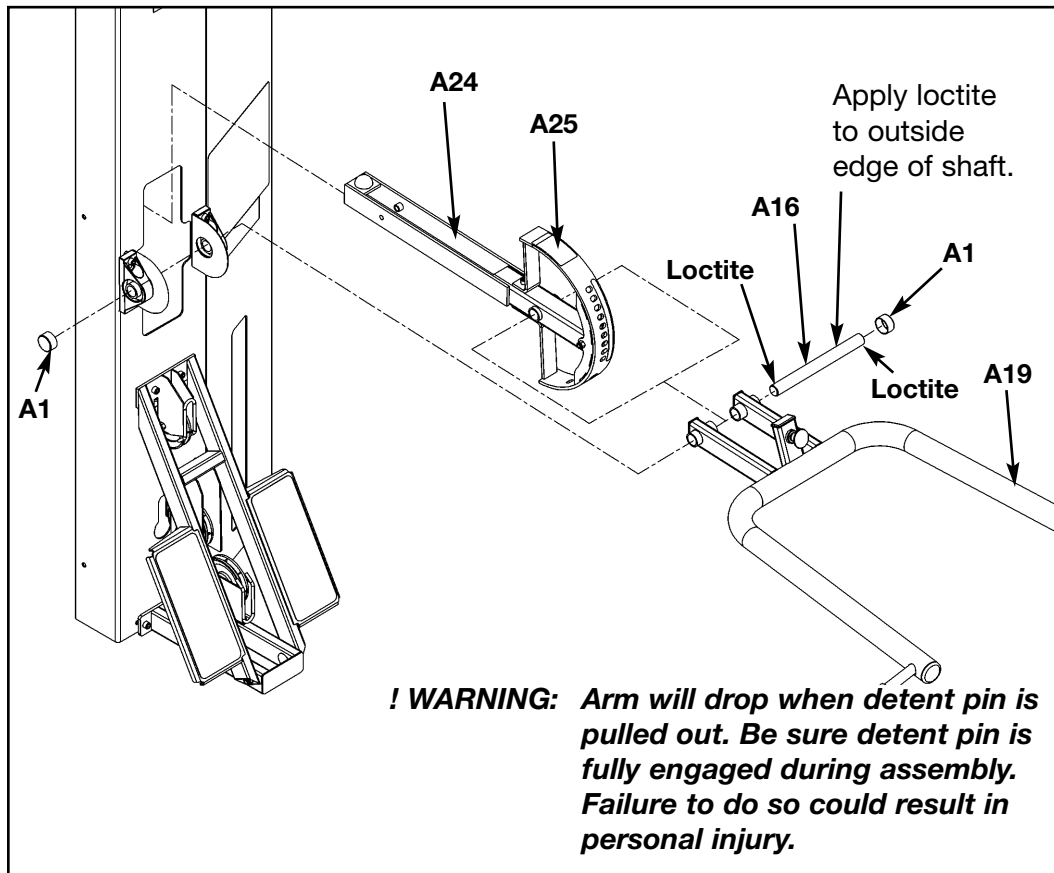

Figure 13

- G. Position shaft and arm so that the arm is centered on the shaft.
- H. Securely tighten the four pillow block bearing bolts.
- I. Tighten pillow block bearing set screws.
- J. With an assistant holding the arm, pull out detent pin and lower arm to lowest position and engage detent pin.
- K. Apply loctite around outside edge of shaft (#A16). Slide a vinyl end cap (#A1) on each end of shaft (#A16).

**7. Install weight stack cable** (see steps 7A - 7I and Figure 14). **NOTE:** *The letters in Figure 14 refer to the steps below (order of when the pulleys are installed and how the cable is routed).*

From the Pressing Station hardware pack, locate weight stack cable (#A49), one pulley (#A4), one SHCS .375-16 x 3.00 (#A31), one nylon locknut .375-16 (#A38), one hex nut .375-16 (#A53) and one jam nut .375-16 (#A54). From the main frame hardware pack, locate four pulleys (#E1), two SHCS .375-16 x 1.75 (#E39), one SHCS .375-16 x 2.50 (#E41), one SHCS .375-16 x 3.00 (#E33), four nylon locknuts .375-16 (#E34), one adjuster (#E14), one pulley tab (#E19), two spacers (#E8) and one cable retainer (#E44).

- A.** Install threaded end of cable (#A49) into location shown in Figure 14, letter A. Place hex nut (#A53) then jam nut (#A54) on cable. Install jam nut so that it is flush with cable end and snug hex nut up to jam nut.
- B.** The first pulley is the hanging pulley. Do not install this pulley at this time. Loop cable down for the first pulley. At the same time, install the second pulley (#E1) using one SHCS .375-16 x 2.50 (#E41) and one nylon locknut (#E34) as shown in Figure 14, letter B.
- C.** At the same time route cable (#A49) down and install third pulley (#A4) using one SHCS .375-16 x 3.00 (#E33) and one nylon locknut (#E34) as shown in Figure 14, letter C.
- D.** At the same time route cable (#A49) upward and install pulley (#A1) using one SHCS .375-16 x 1.75 (#E39) and one nylon locknut (#E34) as shown in Figure 14, letter D.
- E.** Install hanging pulley bracket using one SHCS .375-16 x 3.00 (#E33), one pulley (#E1) two spacers (#E8), one pulley tab (#E19), one adjuster (#E14), one cable retainer (#E44) and one nylon locknut (#E34). Be sure the slotted end of the adjuster is facing outward. Verify cable is resting between the pulley (#E1) and the retainer tab. See Figure 14, letter E.
- F.** At the same time, route cable (#A49) and install fifth pulley (#E1) using one SHCS .375-16 x 1.75 (#E39) and one nylon locknut (#E34). See Figure 14, letter F.
- G.** Route cable (#A49) down to top weight. Place rubber boot (#E3) onto cable and slide cable end into stem of top weight. Drive the spiral pin into top weight/cable end to secure cable.
- H.** Place rubber boot (#E3) over stem of top weight.

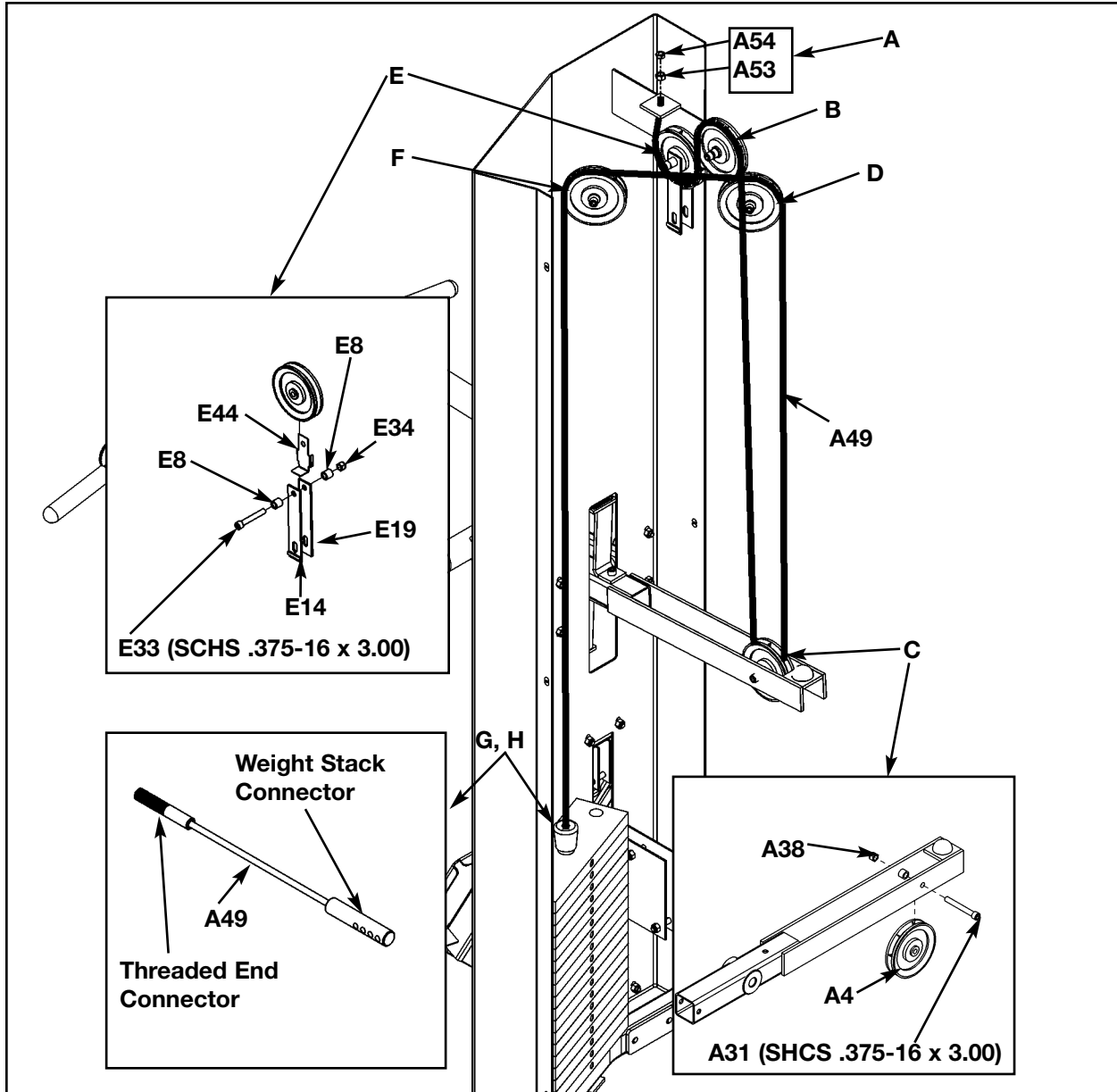

Figure 14

**8. Install the other cable for the Pressing Station** (see steps 8A - 8H and Figure 15).

From the Pressing Station hardware pack, locate cable (#A50), three pulleys (#A1), two SHCS .375-16 x 1.75 (#A40), one SHCS .375-16 x 2.75 (#A14) and three nylon locknuts .375-16 (#A38). From the main frame hardware pack, locate three pulleys (#E1), one cable retainer (#E44), two SHCS .375-16 x 1.75 (#E39) three nylon locknuts .375-16 (#E34), one cam bolt (#E13) and one flat washer (#E37).

- A.** Start routing cable (#A50) as shown in Figure 15, letter A.
- B.** At the same time, install first pulley (#A4) onto the swivel bracket (#A22) and route cable (#A50) using one SHCS .375-16 x 1.75 (#A40) and one nylon locknut (#A38). See Figure 15, letter B.
- C.** At the same time, install second pulley (#A4) using one SHCS .375-16 x 2.75 (#A14) and one nylon locknut (#A38) and route cable. See Figure 15, letter C.
- D.** At the same time, install third pulley (#E1) and route cable (#A50) using one SHCS .375-16 x 1.75 (#A40) and one nylon locknut (#E34). See Figure 15, letter D.
- E.** Route cable (#E50) up to hanging pulley bracket and install pulley (#E1) and cable retainer (#E44) using the cam bolt (#E13), washer (#E37) and nylon locknut (#E34) and route cable. Verify cable is routed between the pulley (#E1) and the retainer tab. See Figure 15, letter E.
- F.** At the same time, install fifth pulley (#E1) and route cable (#A50) using one SHCS .375-16 x 1.75 (#E39). See Figure 15, letter F.
- G.** At the same time, install the last pulley (#A4) and route cable (#A50) using one SHCS .375-16 x 1.75 (#A40) and one nylon lock nut (#A38). See Figure 15, letter G.
- H.** Adjust cable using the cam bolt (#E13) installed in step E to remove slack.

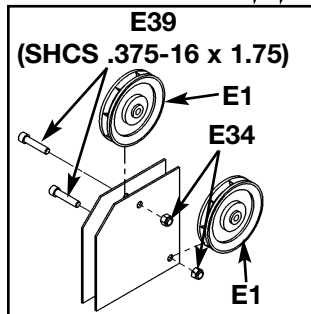
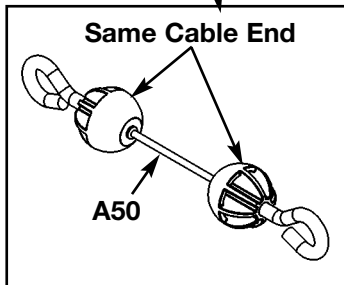
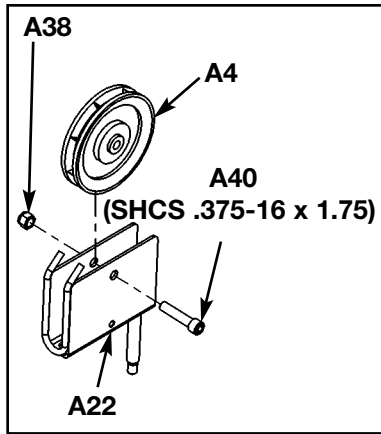
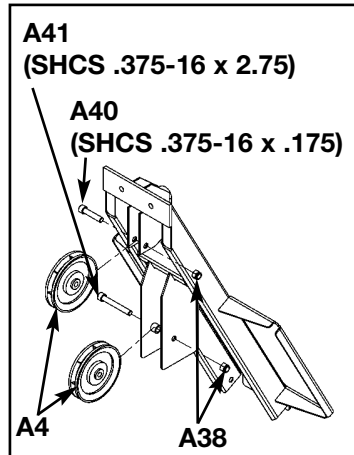
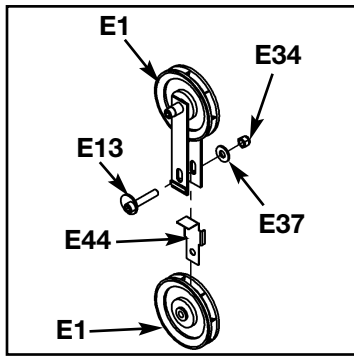
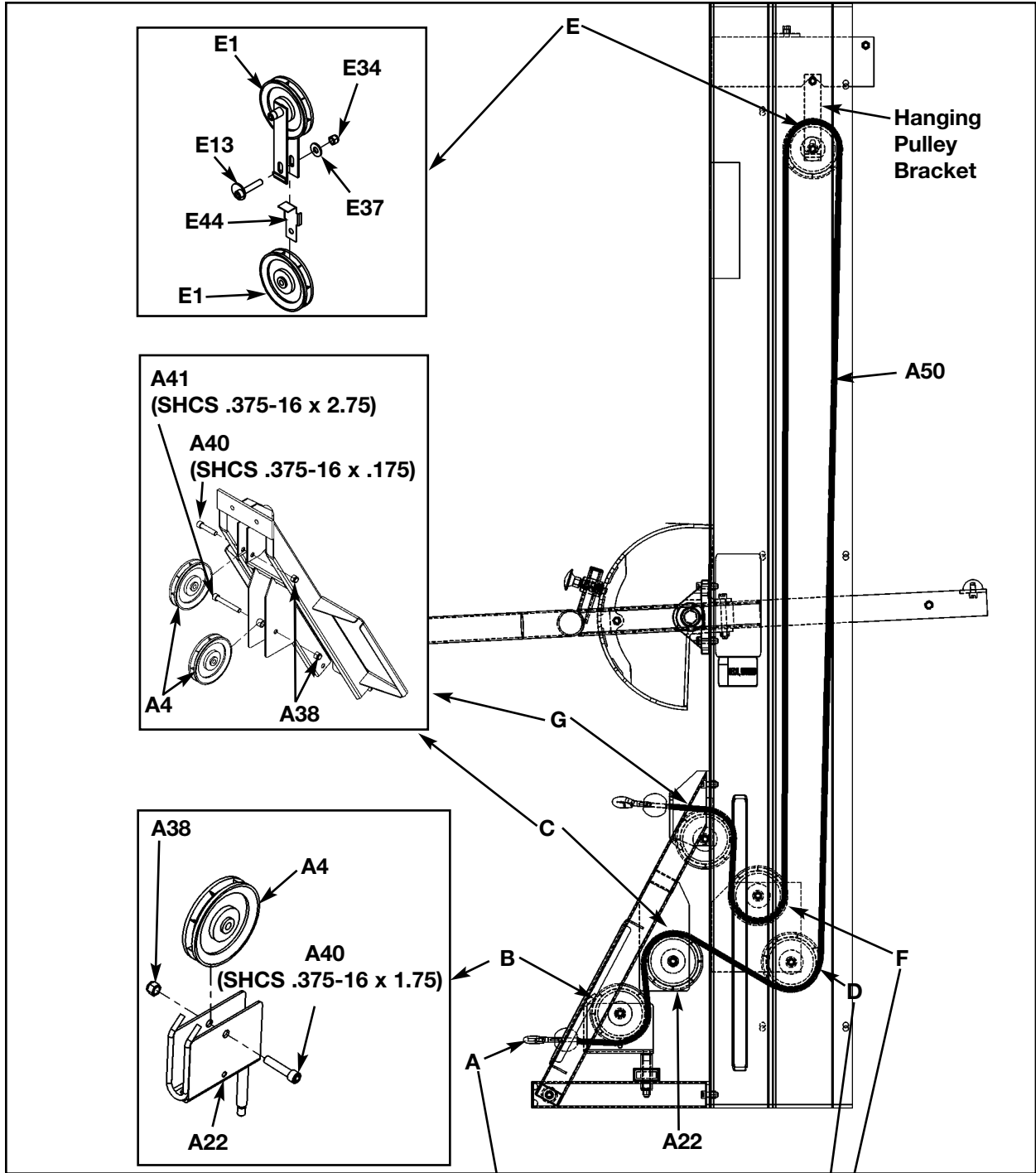

Figure 15

9. Verify all warning and caution decals are present and not damaged (see decals below and Figure 16).

⚠ WARNING

SERIOUS INJURY  
COULD OCCUR IF  
THESE PRECAUTIONS  
ARE NOT OBSERVED

1. Obtain a medical exam prior to beginning an exercise program.
2. Read all warnings and obtain proper instruction on use of the machine prior to using.
3. Keep body and clothing free from and clear of all moving parts.
4. Inspect machine prior to use. DO NOT use if it appears damaged or inoperable.
5. DO NOT attempt to fix a broken or jammed machine. Notify floor staff.
6. Use the machine only for the intended use. DO NOT modify the machine.
7. Be sure that the weight pin is completely inserted. Use only the pin provided by the manufacturer. If unsure seek assistance.
8. Never pin the weights in an elevated position. DO NOT use the machine if found in this condition. Seek assistance from floor staff.
9. Children must not be allowed near this machine. Teenagers must be supervised.
10. DO NOT use if guards are missing or damaged.
11. DO NOT use dumbbells or other incremental weights, except those provided by the manufacturer.
12. Inspect all cables and belts and connections prior to use. DO NOT use if any components are worn, frayed, or damaged.
13. DO NOT REMOVE THIS LABEL. REPLACE IF DAMAGED.

4800-381 B

A

B

⚠ CAUTION

Back cushion may drop when black knob is pulled.  
Support back cushion while adjusting.

Be sure detent pin is fully engaged before use.  
Return back cushion to lowest position when not in use.

Failure to do so could result in personal injury.

8500-028 A

C

⚠ WARNING

Arm will drop when black knob is pulled.  
Support arm while adjusting arm position.

Be sure detent pin is fully engaged before use. Return arm to storage position when not in use.

Failure to do so could result in personal injury.

8500-311 B

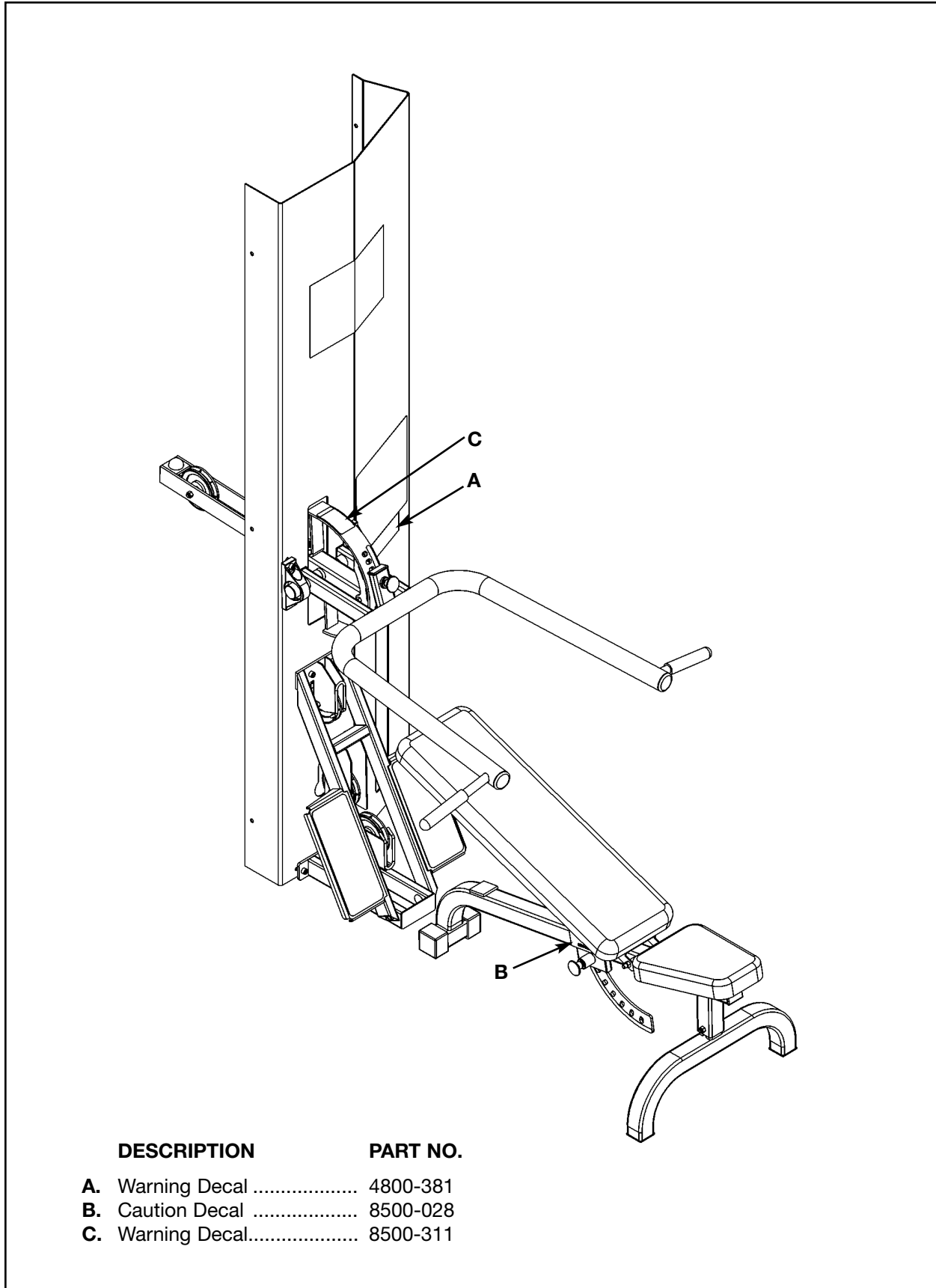
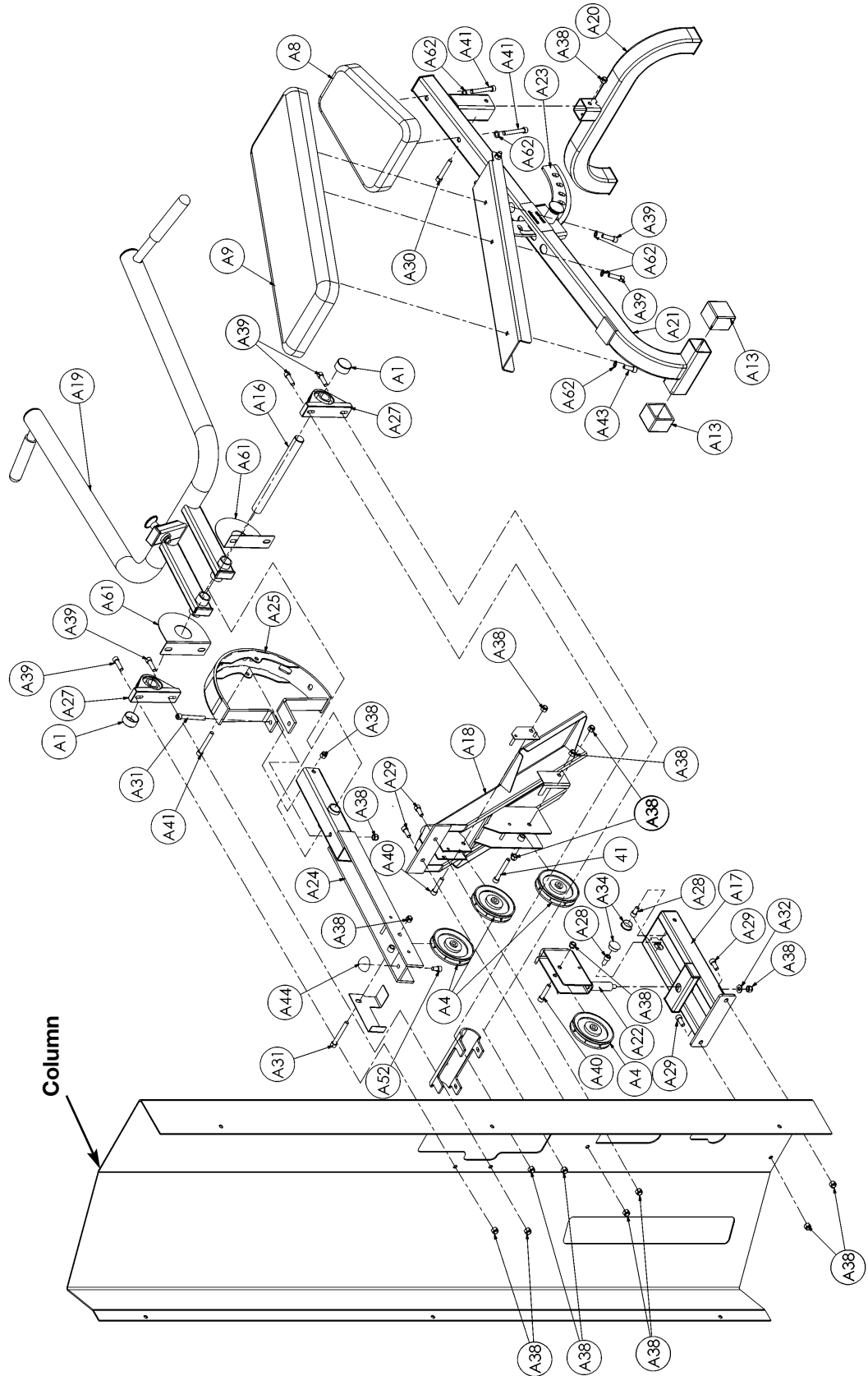

Figure 16

Pressing Station Exploded-View Diagram



**Pressing Station Parts List (not all parts are listed such as pulleys for inside of MG 500 and handles). See Chapter 8 for a complete parts listing.**

| ITEM | QTY | PART NO. | DESCRIPTION           |
|------|-----|----------|-----------------------|
| A1   | 2   | 01190    | Vinyl Black End Cap   |
| A4   | 4   | 02205    | Pulley                |
| A8   | 1   | 4800-019 | Seat Cushion          |
| A9   | 1   | 4800-009 | Back Cushion          |
| A13  | 2   | 8510-344 | Rubber Cap            |
| A16  | 1   | 8610-308 | Shaft                 |
| A17  | 1   | 8610-203 | Brace                 |
| A18  | 1   | 8610-204 | Platform              |
| A19  | 1   | 8610-201 | Pressing Arm          |
| A20  | 1   | 8610-207 | Leg                   |
| A21  | 1   | 8610-210 | Bench Frame           |
| A22  | 1   | 8610-205 | Swivel Pulley Bracket |
| A23  | 1   | 8510-208 | Cushion Plate         |
| A24  | 1   | 8610-202 | Pivot Arm             |
| A25  | 1   | 8510-210 | Detent Plate          |
| A26  | 2   | GQ00206  | Snap Link             |
| A27  | 2   | HB-60652 | Pillow Block Bearing  |

| ITEM | QTY | PART NO. | DESCRIPTION                     |
|------|-----|----------|---------------------------------|
| A28  | 2   | HC702815 | SHCS .375-16 x .750             |
| A29  | 4   | HC702816 | SHCS .375-16 x .875             |
| A30  | 1   | HC702830 | SHCS .375-16 x 2.50             |
| A31  | 4   | HC702834 | SHCS .375-16 x 3.00             |
| A32  | 1   | HS347600 | Flat Washer .375                |
| A34  | 2   | PN660200 | Plastic Insert 1.00 Dia. x 11 G |
| A38  | 18  | HN704901 | Nylon Locknut .375-16           |
| A39  | 6   | JC702820 | SHCS .375-16 x 1.25             |
| A40  | 2   | JC702824 | SHCS .375-16 x 1.75             |
| A41  | 2   | JC702832 | SHCS .375-16 x 2.75             |
| A43  | 1   | HC702817 | SHCS .375-16 x 1.00             |
| A44  | 1   | 4505-331 | Bumper                          |
| A52  | 1   | JC702814 | SHCS .375-16 x .625             |
| A53  | 1   | HN704000 | Hex Nut .375-16                 |
| A54  | 1   | HN704400 | Jam Nut .375-16                 |
| A61  | 2   | 8610-330 | Guard                           |
| A62  | 5   | JS347400 | Internal Tooth Lockwasher       |

*This page intentionally left blank*

**Leg Extension/Leg Curl Station Diagram**

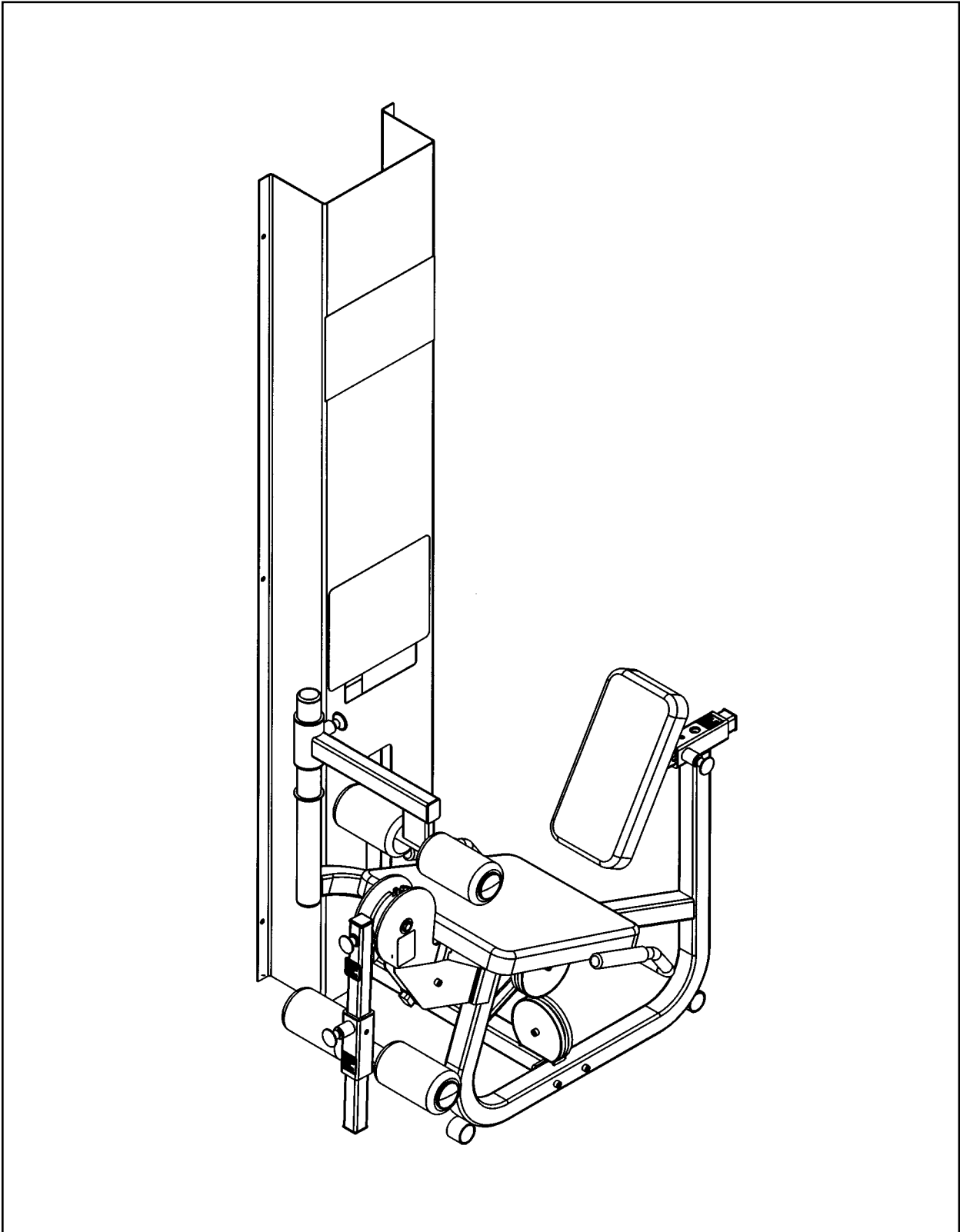

**Leg Extension/Leg Curl Station Assembly**

1. Verify contents of the Leg Extension/Leg Curl Station boxes (see steps 1A - 1C and Figures 1-3).

- A. Locate the Leg Extension/Leg Curl box (containing the frame).
- B. Locate the Leg Extension/Leg Curl Station cushion box (removed from the main frame assembly).
- C. Verify contents of both boxes. See Figures 1-3.

| ITEM | QTY | PART NO. | DESCRIPTION                     |
|------|-----|----------|---------------------------------|
| D9   | 1   | 4850-202 | Right Handle                    |
| D10  | 1   | 4850-203 | Left Handle                     |
| D13  | 4   | 4800-135 | Round Cushion w/Wear Cover      |
| D14  | 1   | 8520-308 | Leg Curl Tube                   |
| D19  | 1   | 8640-002 | Cable 132.12 L                  |
| D20  | 1   | 8640-003 | Cable 83.49 L                   |
| D21B | 1   | 8640-213 | Frame                           |
| D22  | 1   | 8640-201 | Cushion Post (for Back Cushion) |
| D23  | 1   | 8640-202 | Cam                             |
| D24  |     |          | Removed 3/20/01                 |
| D25  | 1   | 8640-204 | Adjuster                        |
| D26  |     |          | Removed 3/20/01                 |
| D27  | 1   | 8640-206 | Leg                             |
| D28  | 1   | 8640-207 | Brace                           |
| D29  |     |          | Removed 3/20/01                 |
| D46  | 4   | PP080223 | Plastic Insert                  |
| D49  | 1   | 4800-021 | Back Cushion                    |
| D50B | 1   | 4800-074 | Seat Cushion                    |
| D58  | 1   | 02120    | Pulley Mount                    |
| D60  | 1   | 8640-211 | Cushion Bracket                 |
| D61  | 1   | 8640-212 | Cushion Post                    |
| D62  | 1   | 8640-214 | Leg Bar                         |
| D63  | 1   | 8640-334 | Support Plate                   |
|      | 1   |          | Hardware Pack                   |

Figure 1

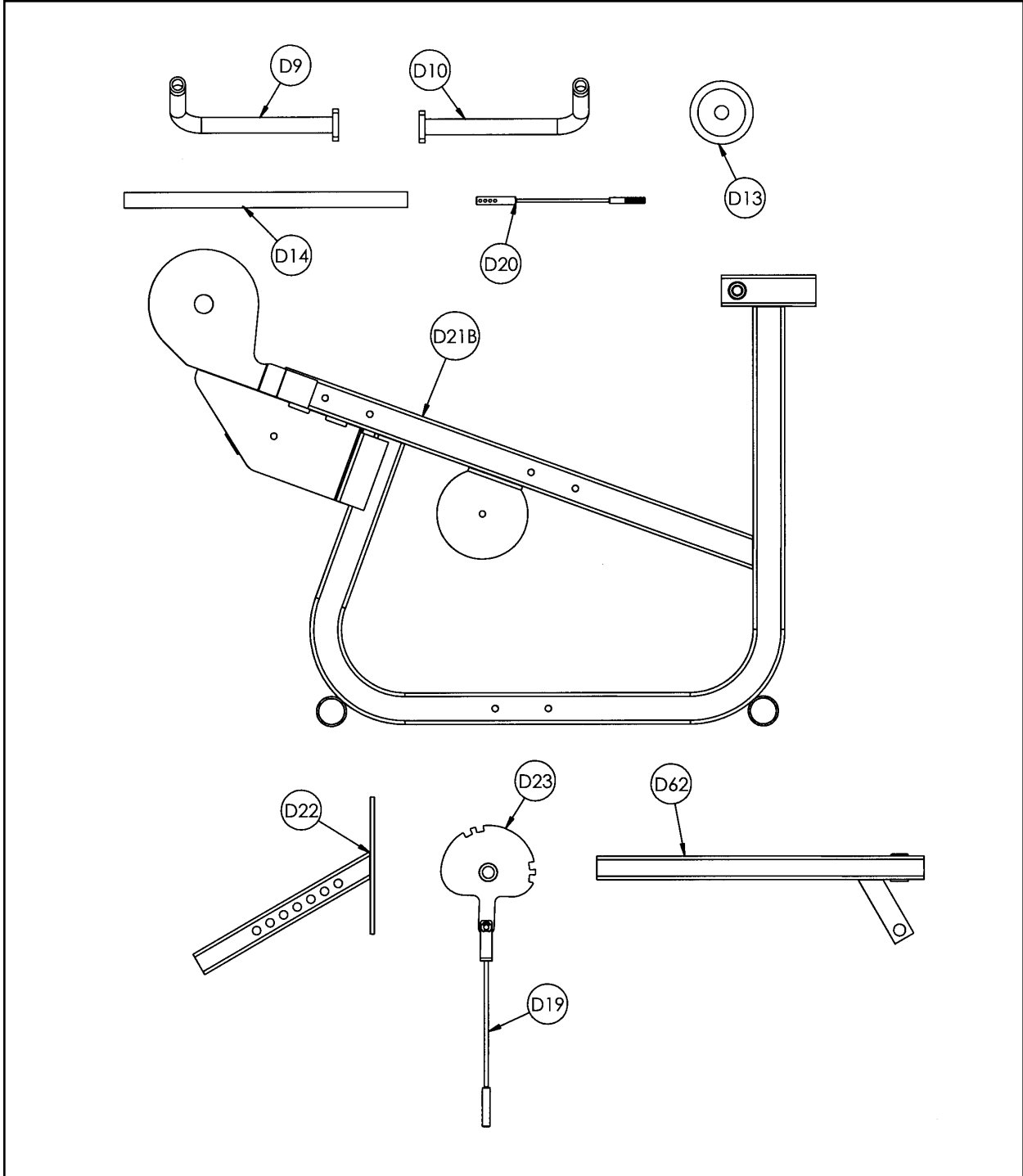

Figure 2

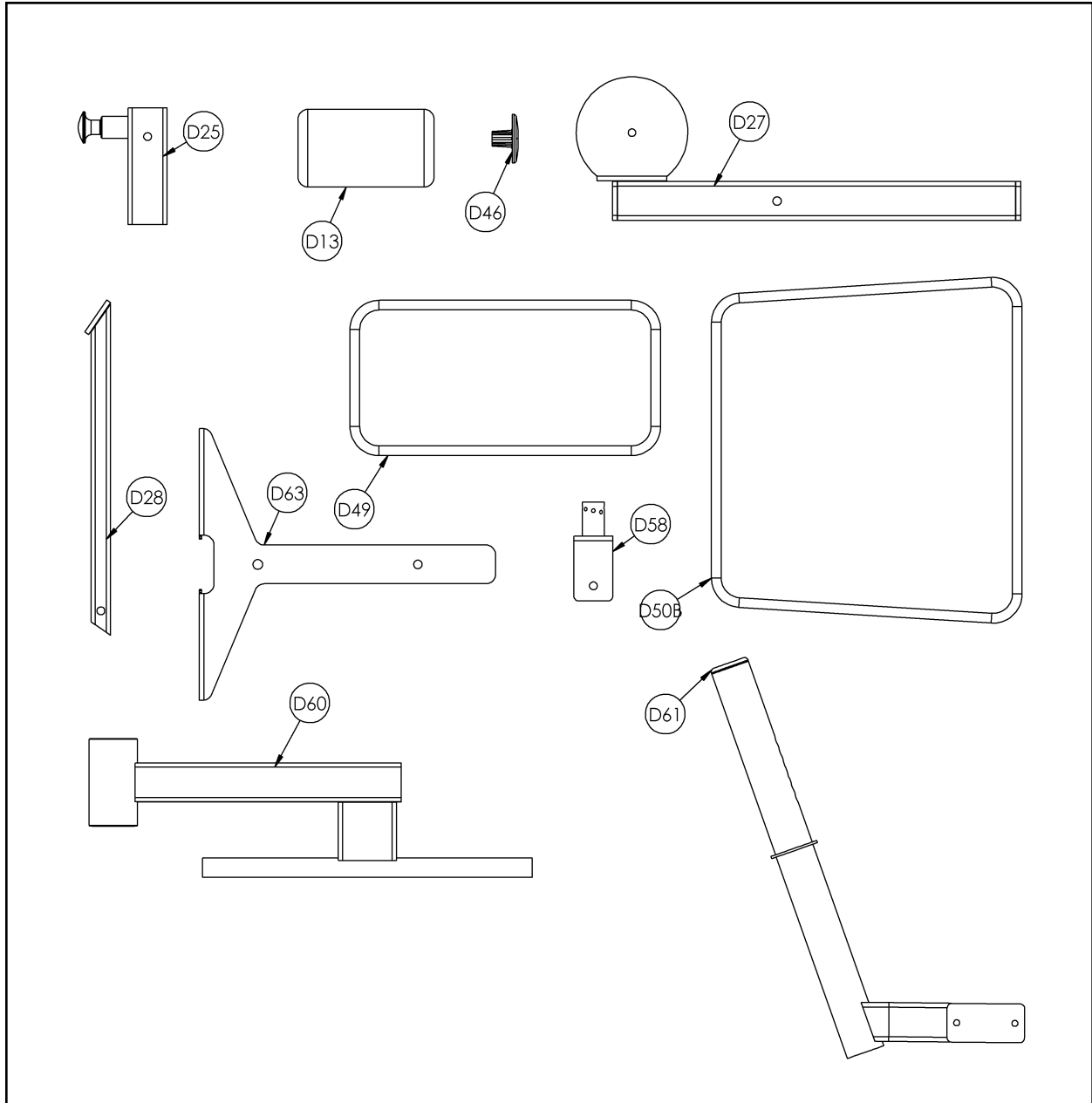

Figure 3

**2. Verify contents of the Leg Extension/Leg Curl hardware pack (see steps 2A, 2B, Figures 3 and 4).**

- A.** Locate hardware pack.
- B.** Verify contents of hardware pack. If desired, sort out hardware into different containers. Do not combine hardware with other hardware packs. See Figures 3 and 4 for contents of hardware pack.

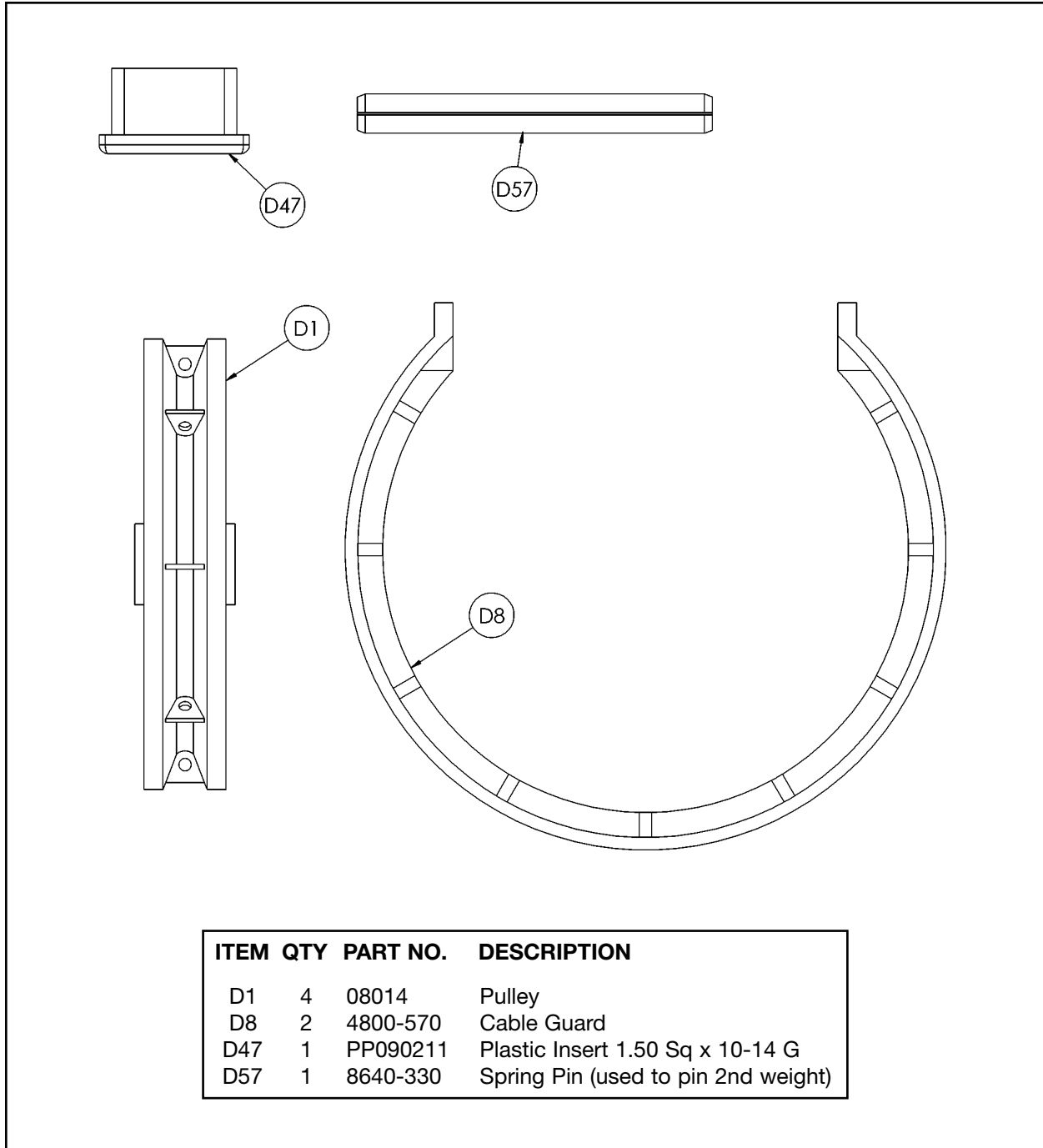

Figure 4

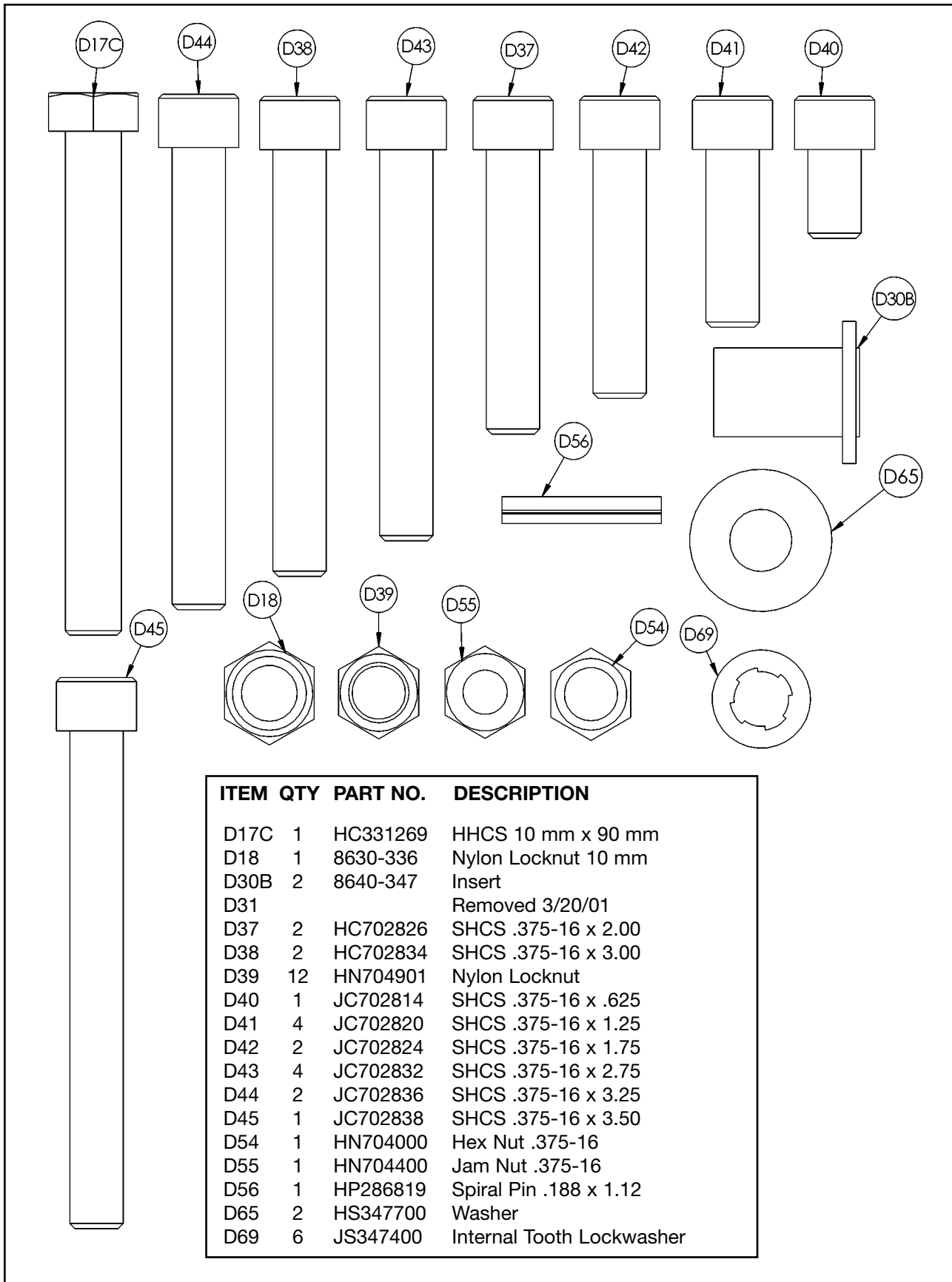

Figure 5

**3. Assemble leg and seat frame to column** (see steps 3A - 3D and Figure 6).

- A. Locate leg (#D27), two SHCS .375-16 x 1.25 (#D41) and two nylon lock nuts (#D39).
- B. Attach leg (#D27) to column using two SHCS .375-16 x 1.25 (#D41) and two nylon locknuts (#D39) as shown in Figure 4. **NOTE:** Do not securely tighten hardware at this time.
- C. Locate seat frame (#D21B), two SHCS .375-16 x 2.75 (#D43) and two nylon locknuts (#D39).
- D. Attach seat frame (#D21B) to leg (#D27) using two SHCS .375-16 x 2.75 (#D43) and two nylon locknuts (#D39) as shown in Figure 4. **NOTE:** Do not securely tighten hardware at this time.

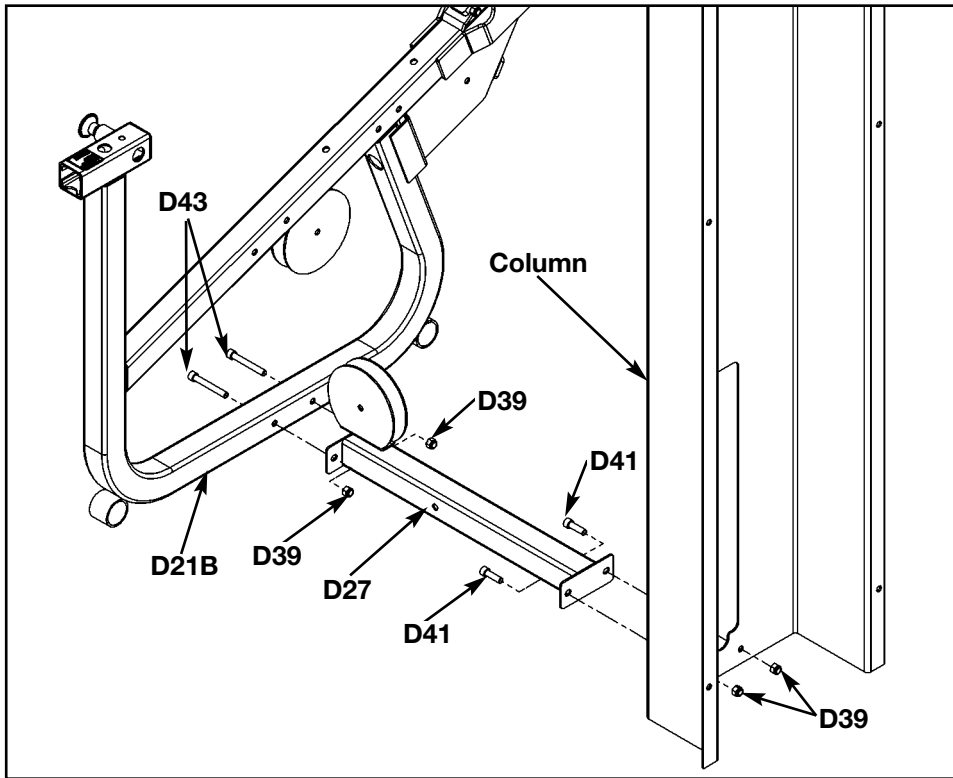

Figure 6

4. Install brace (see steps 4A - 4D and Figure 7).

- A. Locate brace (#D28), one SHCS .375-16 x 3.50 (#D45), one SHCS .375-16 x 2.00 (#D37) and two nylon locknuts .375-16 (#D39).
- B. Attach lower portion of brace (#D28) to leg (#D27) using SHCS .375-16 x 3.50 (#D45) as shown in Figure 7.
- C. Attach top end of brace (#D28) using one SHCS .375-16 x 2.00 (#D37) as shown in Figure 7.

**NOTE:** Do not tighten SHCS (#D37 and #D45) at this time as the SHCS (#D37) will need to be removed when installing the pulley.

- D. Securely tighten hardware from step #3 on previous page.

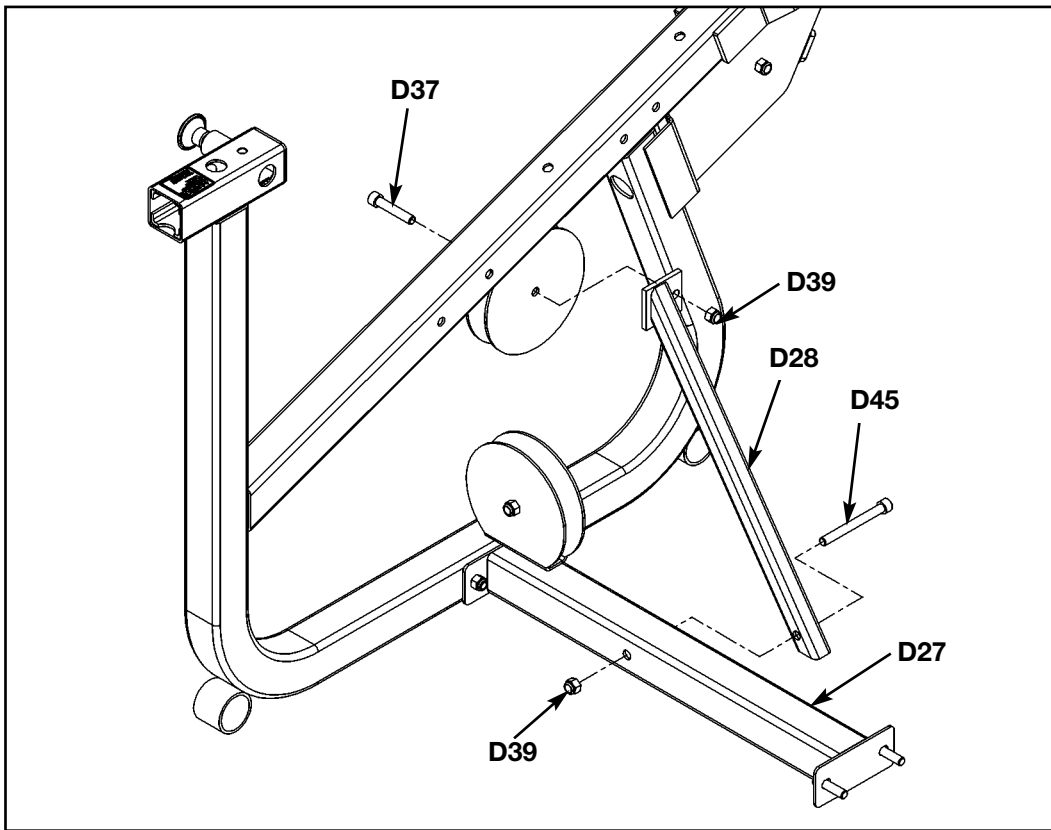

Figure 7

**5. Install left and right handles** (see steps 5A, 5B and Figure 8).

- A.** Locate (user position) right handle (#D9), left handle (#D10), two SHCS .375-16 x 3.25 (#D44) and two nylon locknuts .375-16 (#D39).
- B.** Install left and right handles (#D9 and #D10) using two SHCS .375-16 x 3.25 (#D44) and two nylon locknuts (#D39) as shown in Figure 8.

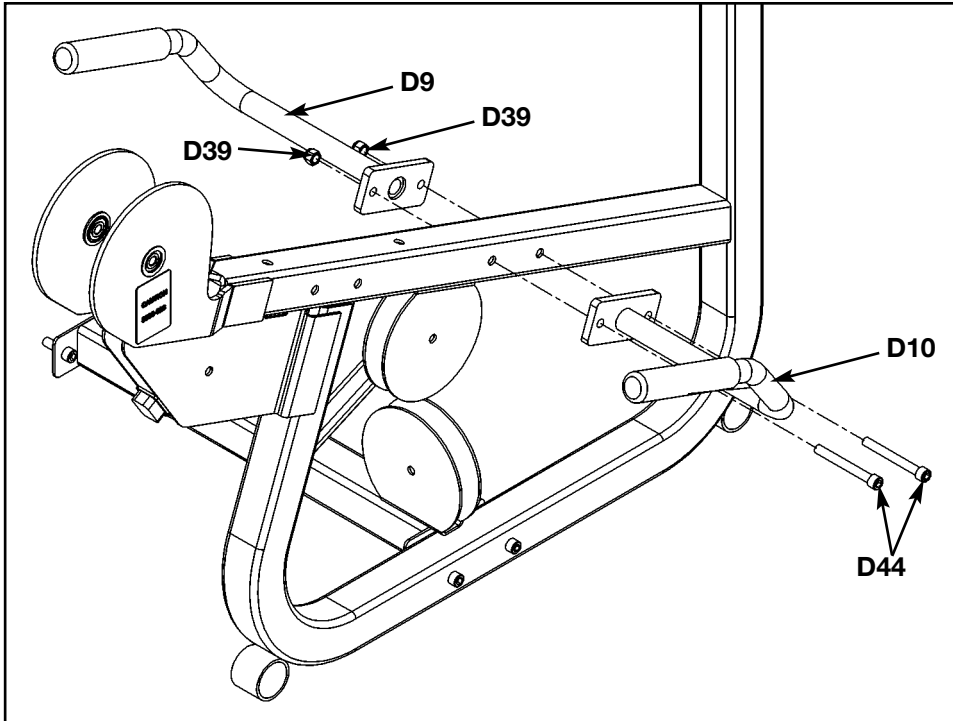

Figure 8

**6. Install cushion post to seat frame** (see steps 6A, 6B and Figure 9).

- A. Locate cushion post (#D22).
- B. Pull detent pin and slide cushion post (#D22) into seat frame (#D21B) as shown in Figure 9.

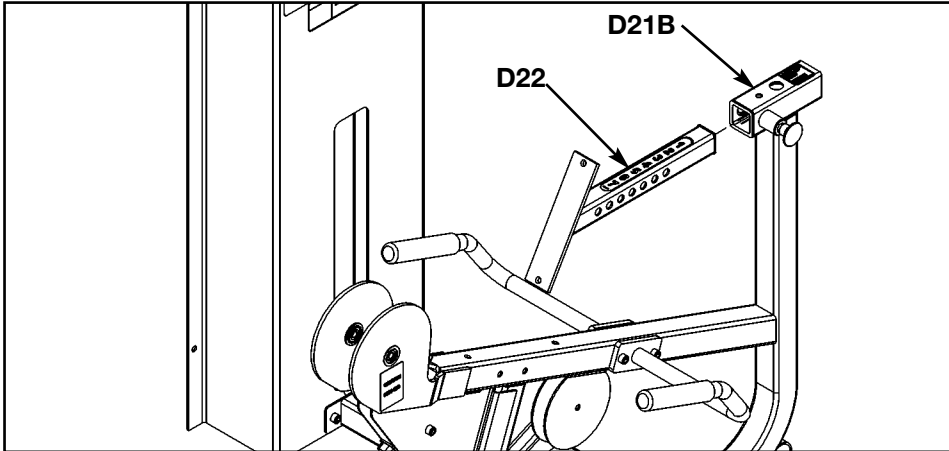

Figure 9

**7. Install cam assembly** (see steps 7A - 7D, Figures 10 and 11).

- A. Locate cam (#D23) and two inserts (#D30B).
- B. Attach cam (#D23) to leg bar (#D62) using two inserts (#D30B) as shown in Figure 10.

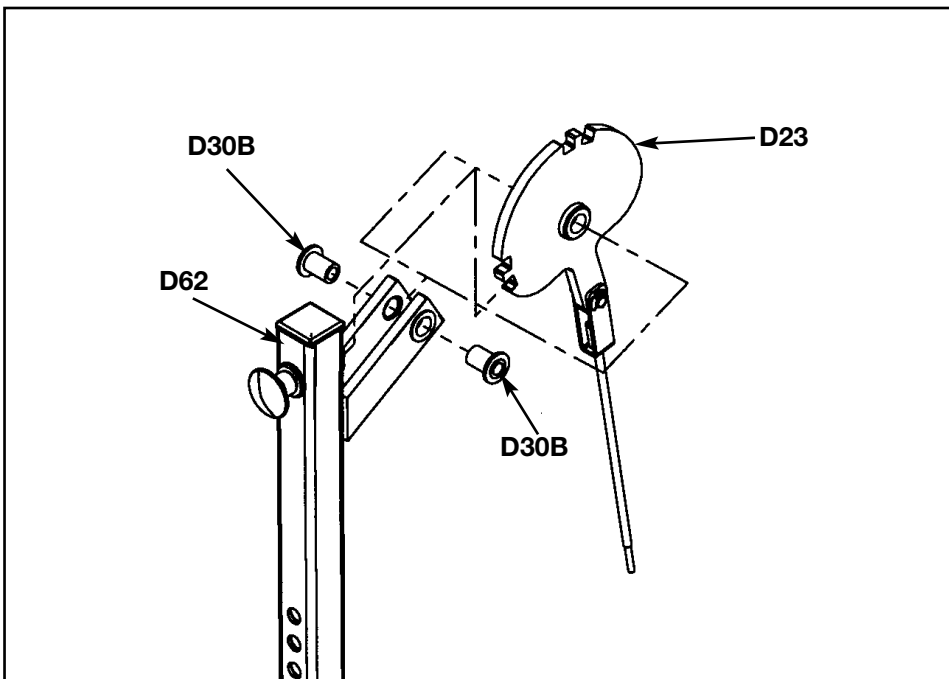

Figure 10

- C.** Locate one HHCS 10 mm x 90 mm (#D17C) and one nylon locknut 10 mm (#D18) and two internal tooth lockwashers (#D69).
- D.** Install cam assembly onto frame (#D21B) using one HHCS 10 mm x 90 mm (#D17C), one nylon locknut 10 mm (#D18) and two internal tooth lockwashers (#D69) as shown in Figure 11.

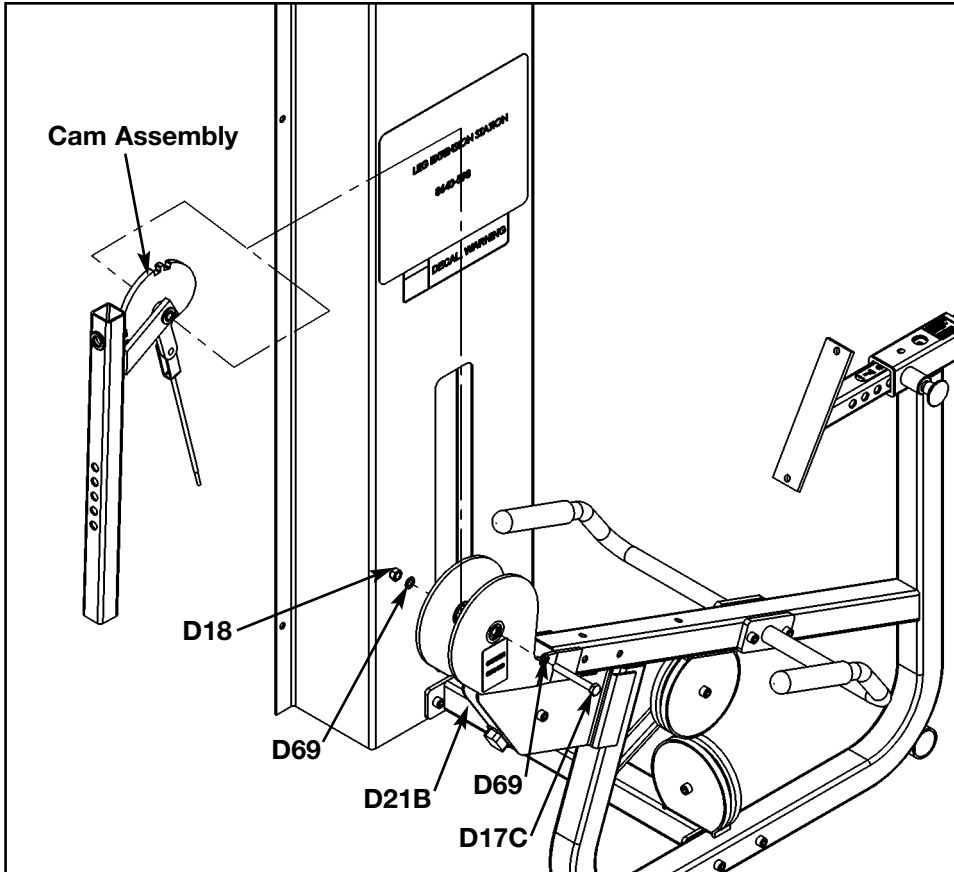

Figure 11

**8. Install adjuster** (see steps 8A - 8D and Figures 12A - 12C).

- A.** Locate adjuster (#D25) and slide it onto the leg post as shown in Figure 12A.
- B.** Locate one SHCS .375-16 x .625 (#D40) and one nylon locknut (#D39).
- C.** Install SHCS .375-16 x .625 (#D40) and one nylon locknut (#D39) as shown in Figure 12B. Tighten hardware securely.
- D.** Locate and install the plastic insert (#D47) as shown in Figure 12C.

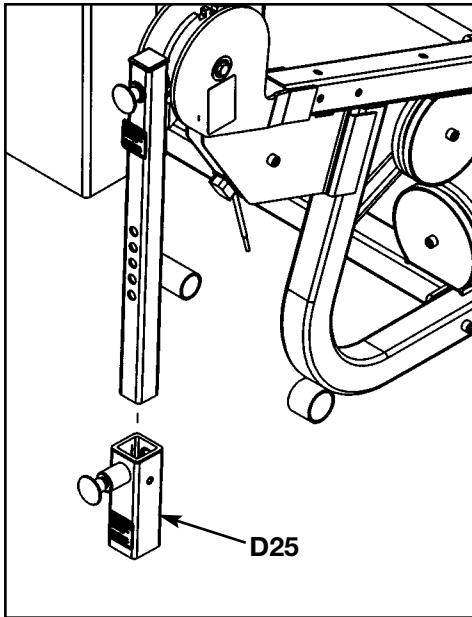

Figure 12A

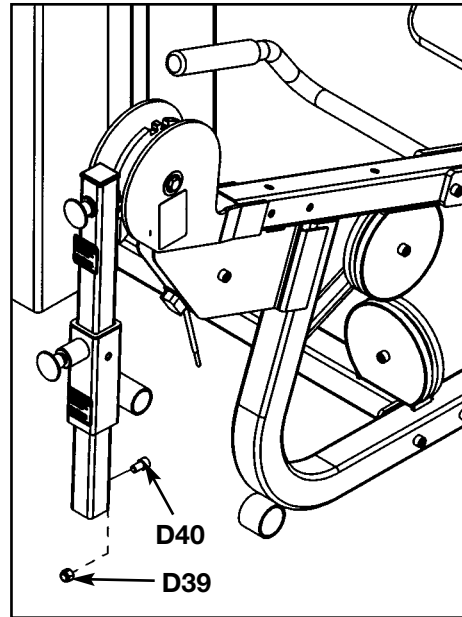

Figure 12B

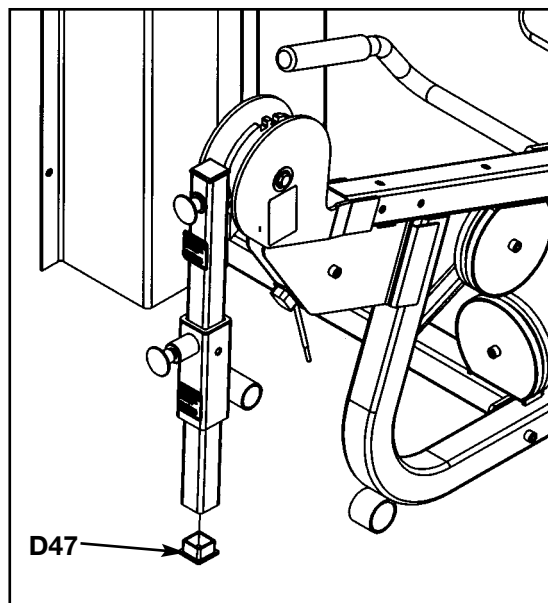

Figure 12C

**9. Install cushions** (see steps 9A - 9I, Figures 13 and 14).

- A.** Locate leg curl tube (#D14), two round cushions (#D13) and two plastic inserts (#D46).
- B.** Slide leg curl tube (#D14) onto adjuster and install both round cushions as shown in Figure 13.
- C.** Install two plastic inserts (#D46) using a rubber mallet. See Figure 13.

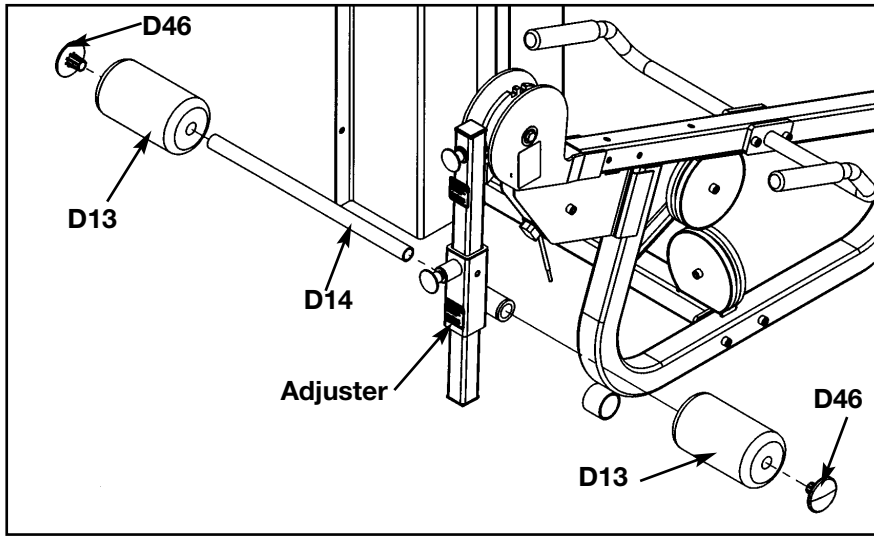

Figure 13

- D. Locate cushion post (#D61), two washers (#D65) and two SHCS (#D43).
- E. Install cushion post (#D61) using two washers (D65) and two SHCS (#D43). See Figure 14.
- F. Locate cushion bracket (#D60), two round cushions (#D13) and two plastic inserts (#D46).
- G. Slide both cushions (#D13) onto cushion bracket (#D60).
- H. Install two plastic inserts (#D46) using a rubber mallet. See Figure 15.
- I. Pull out detent pin and slide cushion bracket (#D60) onto cushion post (#D61) as shown in Figure 14.

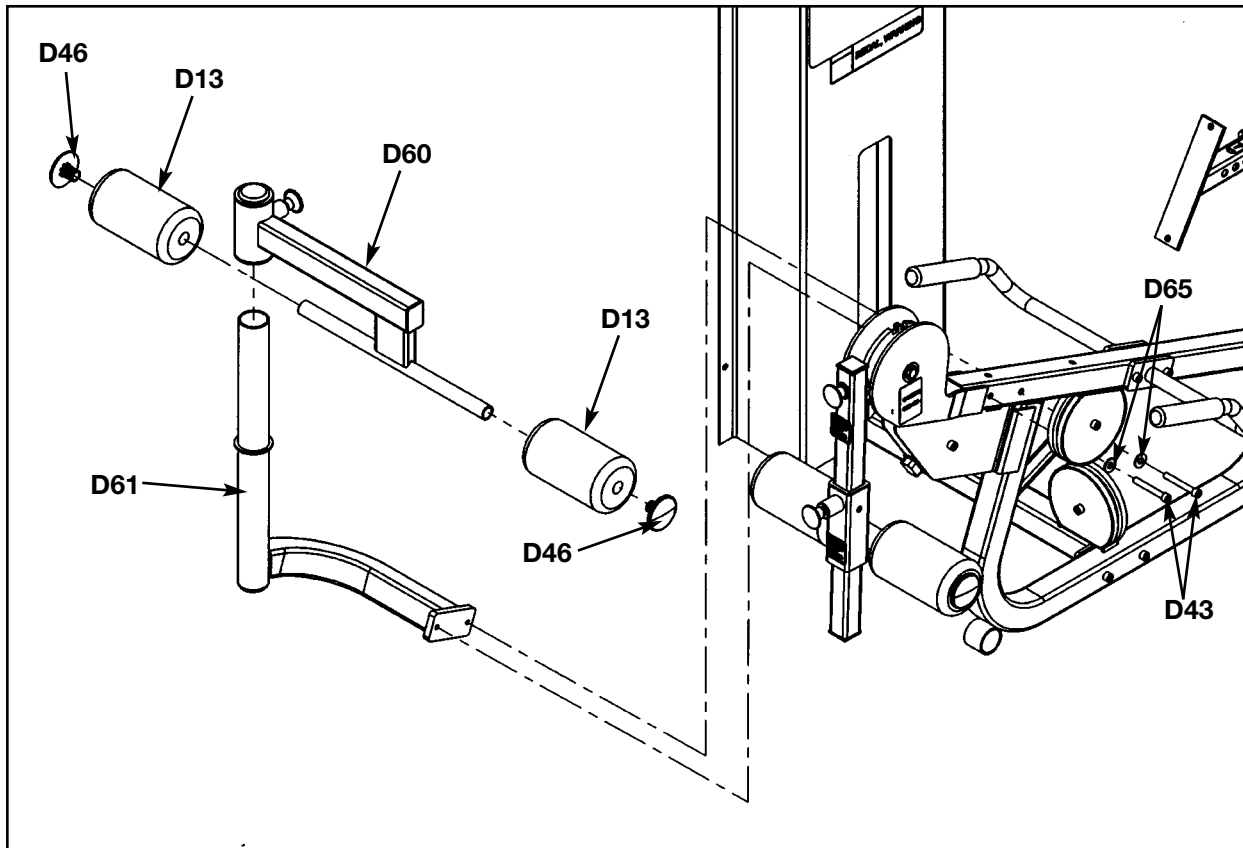

Figure 14

**8. Install seat and back cushions** (see steps A - D and Figure 15).

- A.** Locate seat cushion (#D50), back cushion (#D49), two SHCS .375-16 x 3.00 (#D38), two SHCS .375-16 x 1.25 (#D41), support plate (#63) and four internal tooth lockwashers (#D69).
- B.** Place support plate (D63) onto frame as shown in Figure 15).
- C.** Insert one SHCS .375-16 x 3.00 (#D38) and one internal tooth lockwasher (#D69) through frame and cushion plate and seat cushion. Then install the other SHCS and internal tooth lockwasher.
- D.** Install back cushion (#D49) using two SHCS .375-16 x 1.25 (#D41) and two internal tooth lockwashers (#D69) as shown in Figure 15.

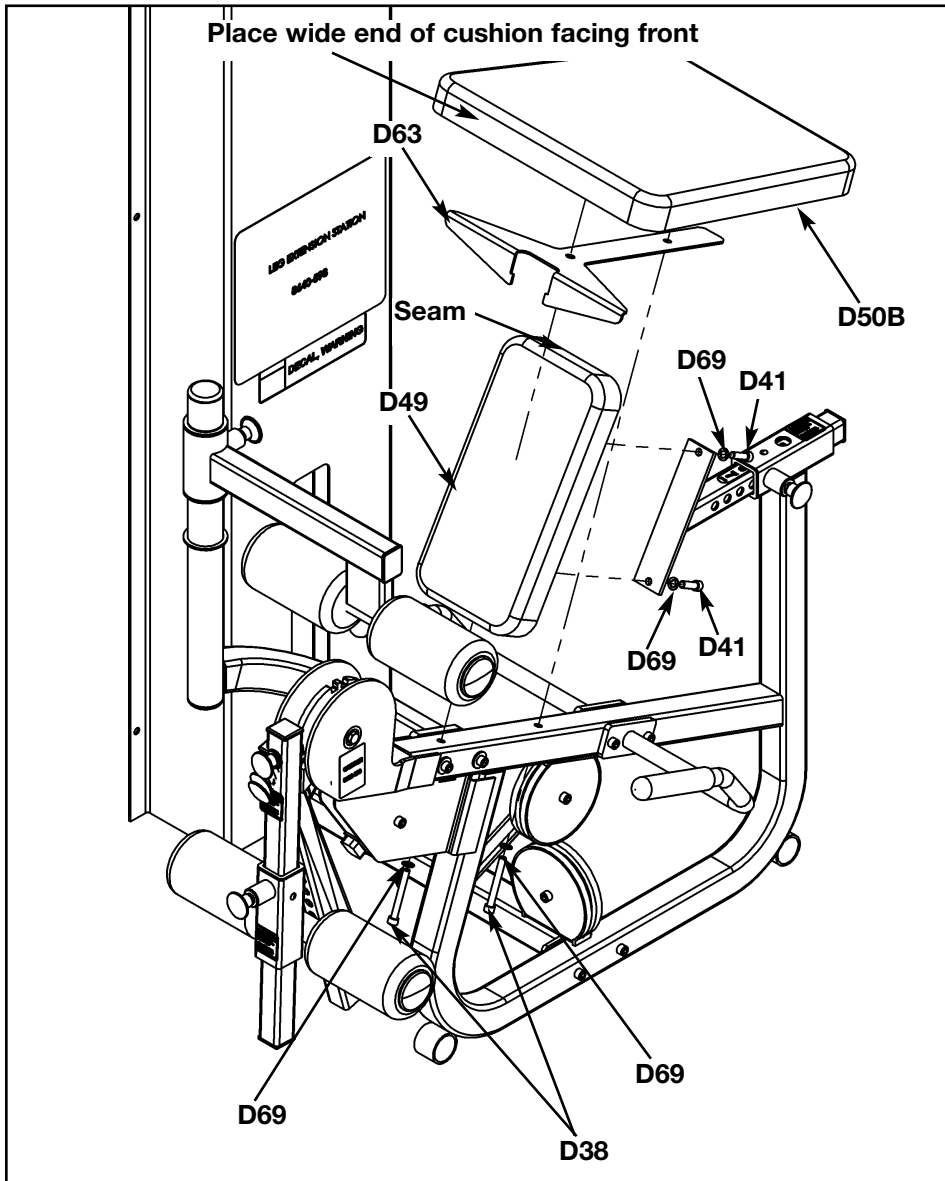

Figure 15

**9. Install and route cables** (see steps 9A - 9M and Figure 16)

From the Leg Extension/Leg Curl hardware pack, locate weight stack cables (#D19) and (#D20), four pulleys (#D1), two cable guards (#D8), two SHCS .375-16 x 1.75 (#D42), one SHCS .375-16 x 2.00 (#D37), two nylon locknuts (#D39), one hex nut (#D54), one jam nut (#D55) and pulley mount (#D55). From the main frame hardware pack, locate two pulleys (#E1), two SHCS .375-16 x 1.75 (#E39), two nylon locknuts (#E34) and one spiral pin (#E35).

- A.** At the same time, install pulley (#D1) and route cable (#D19) using one SHCS .375-16 x 1.75 (#D42) and one nylon locknut (#D39). See Figure 16, letter A.
- B.** Route cable (#D19) through frame. See Figure 16, letter B.
- C.** Remove the SHCS .375-16 x 2.00 (#D37). Loop cable (#D19) through cable guard (#D8) and install next pulley (#D1) and cable guard (#D8) using the SHCS .375-16 x 2.00 (#D37) and nylon locknut (#D39) that was just removed. See Figure 16, letter C.
- D.** Loop cable (#D19) through the second cable guard (#D8) and install the next pulley (#D1) using SHCS .375-16 x 1.75 (#D42) and one nylon locknut (#D39). See Figure 16, letter D.
- E.** Route cable (#D19) to inside of column as shown in Figure 16, letter E.
- F.** At the same time, route cable (#D19) and install the next pulley (#E1) using one SHCS .375-16 x 1.75 (#E39) and one nylon locknut (#E34). See Figure 16, letter F. Set cable down.
- G.** Using the weight stack cable (#D20), attach one end as shown in Figure 16, letter G. Install hex nut (#D54) first and then jam nut (#D55). Position jam nut (#D55) so it is even with cable end.
- H.** The hanging pulley will be installed in the next step. At the same time, route cable (#D20) and install the last pulley (#E1) before the weight stack, using one SHCS .375-16 x 1.75 (#E39) and one nylon locknut (#E34). Set cable down.
- I.** Pick up the other cable (#D19) and install the pulley mount (#D55). Drive a spiral pin (#D53) through cable end and pulley mount (#D55) as shown in Figure 16, letter I.
- J.** Wrap a portion of the weight stack cable (#D20) around the last pulley (#D1) to be installed. At the same time, route cable (#D20) and install the last pulley (#D1) using one SHCS .375-16 x 2.00 (#D37) and one nylon locknut (#D39). See Figure 16, letter J.
- K.** Slide rubber boot onto cable (#D20). Drive a spiral pin (#E35) through top weight connector and cable (#D20). Top weight should be snug (just resting on the second plate). See Figure 16, letter K.
- L.** If necessary, adjust hex nut (#D51) to remove any slack.
- M.** Securely tighten hardware.

**NOTE:** All cables will be adjusted after verification of the warning and caution decals for the Leg Extension/Leg Curl.

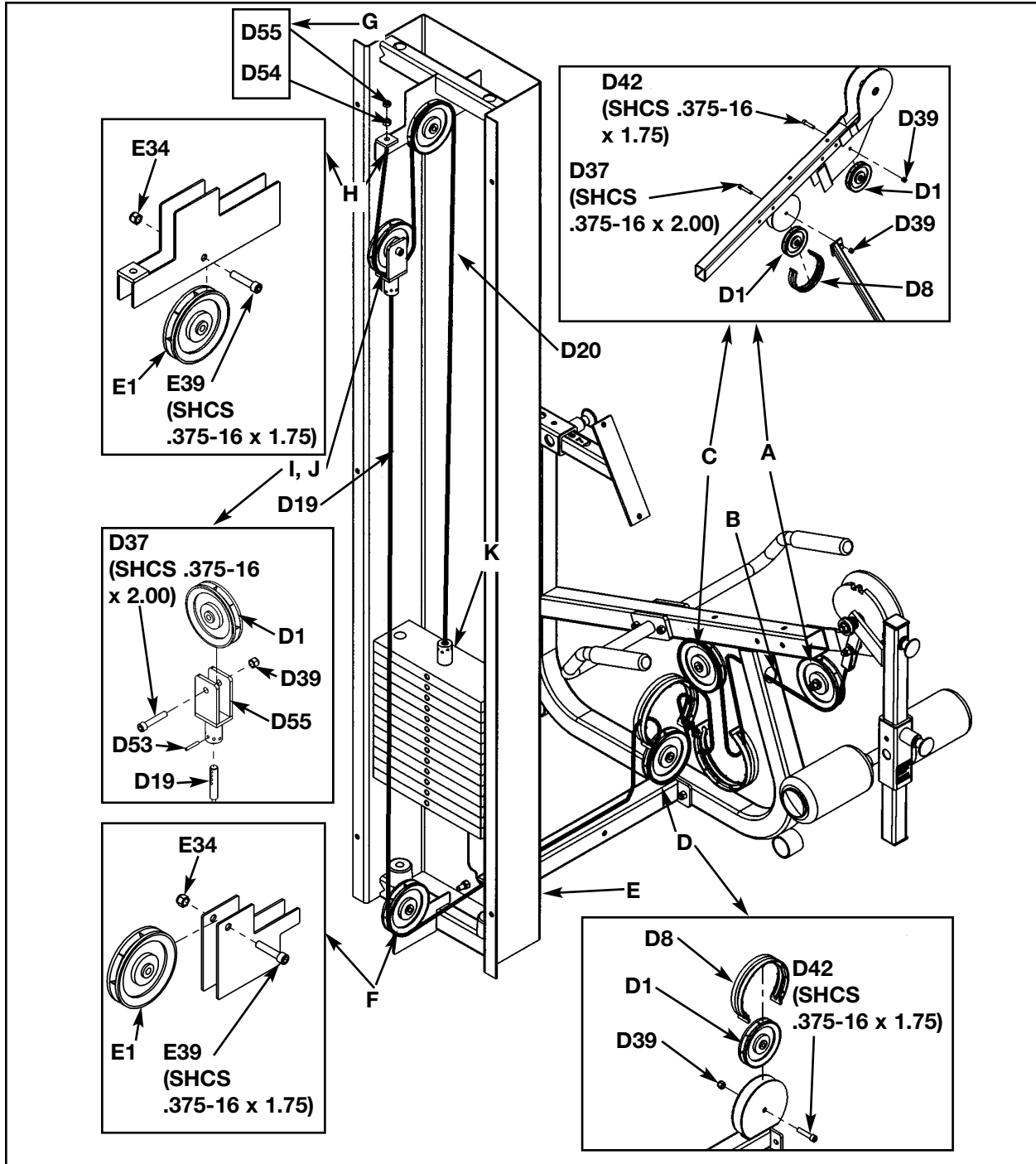



Figure 16

9. Verify all warning and caution decals are present and not damaged (see decals below and Figure 17).

|   |  |
|---|--|
|  <p><b>WARNING</b></p>   | <p><b>SERIOUS INJURY<br/>COULD OCCUR IF<br/>THESE PRECAUTIONS<br/>ARE NOT OBSERVED</b></p> |
| <ol style="list-style-type: none"> <li>1. Obtain a medical exam prior to beginning an exercise program.</li> <li>2. Read all warnings and obtain proper instruction on use of the machine prior to using.</li> <li>3. Keep body and clothing free from and clear of all moving parts.</li> <li>4. Inspect machine prior to use. DO NOT use if it appears damaged or inoperable.</li> <li>5. DO NOT attempt to fix a broken or jammed machine. Notify floor staff.</li> <li>6. Use the machine only for the intended use. DO NOT modify the machine.</li> <li>7. Be sure that the weight pin is completely inserted. Use only the pin provided by the manufacturer. If unsure seek assistance.</li> <li>8. Never pin the weights in an elevated position. DO NOT use the machine if found in this condition. Seek assistance from floor staff.</li> <li>9. Children must not be allowed near this machine. Teenagers must be supervised.</li> <li>10. DO NOT use if guards are missing or damaged.</li> <li>11. DO NOT use dumbbells or other incremental weights, except those provided by the manufacturer.</li> <li>12. Inspect all cables and belts and connections prior to use. DO NOT use if any components are worn, frayed, or damaged.</li> <li>13. DO NOT REMOVE THIS LABEL. REPLACE IF DAMAGED.</li> </ol> |  |
| <p>4800-381 B</p>   |  |

A

B

|   |
|---|
|  <p><b>CAUTION</b></p>                                 |
| <p>Failure to correctly adjust could result in personal injury.</p> <p>Always fully engage the detent pin before use to avoid injury.</p> |
| <p>8500-025 B</p>   |

C

|   |
|---|
|  <p><b>CAUTION</b></p> |
|                        |
| <p>Keep away from moving parts. Failure to do so could result in personal injury.</p>                       |
| <p>8500-026 A</p>   |

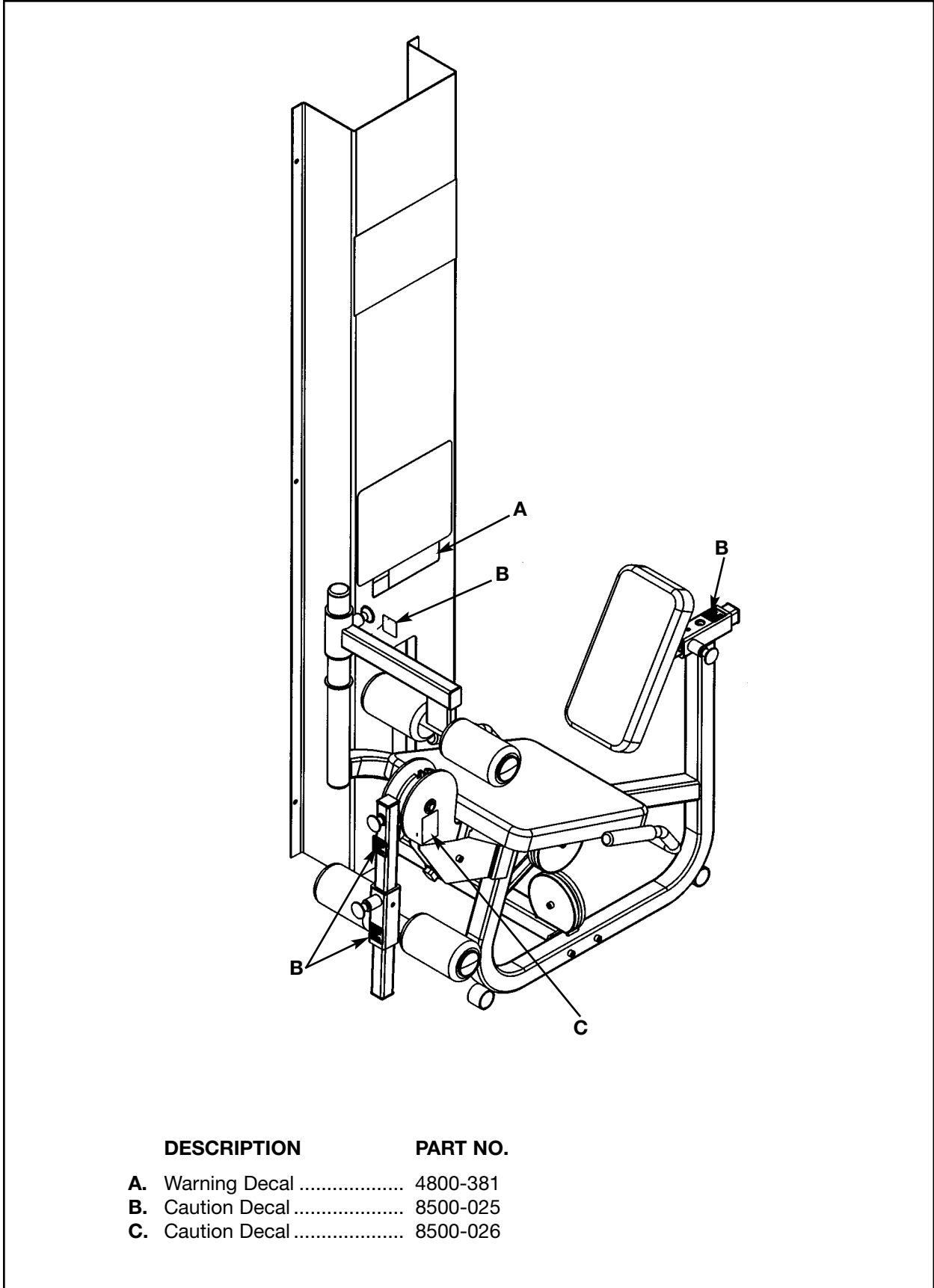

| DESCRIPTION            | PART NO. |
|------------------------|----------|
| A. Warning Decal ..... | 4800-381 |
| B. Caution Decal ..... | 8500-025 |
| C. Caution Decal ..... | 8500-026 |

Figure 17



**Leg Extension/Leg Curl Station Parts List (not all parts are listed such as pulleys and cables for inside of MG 500). See Chapter 8 for a complete parts listing.**

| ITEM | QTY | PART NO. | DESCRIPTION                       |
|------|-----|----------|-----------------------------------|
| D1   | 4   | 08014    | Pulley                            |
| D8   | 2   | 4800-570 | Cable Guard                       |
| D9   | 1   | 4850-202 | Right Handle                      |
| D10  | 1   | 4850-203 | Left Handle                       |
| D13  | 4   | 8500-052 | Cushion 4.00 Dia. x 7.00 L x .875 |
| D14  | 1   | 8520-308 | Leg Curl Tube                     |
| D17C | 1   | HC331269 | HHCS 10 mm x 90 mm                |
| D18  | 1   | 8630-336 | Nylon Locknut 10 mm               |
| D21A | 1   | 8640-213 | Frame                             |
| D22  | 1   | 8640-201 | Cushion Post                      |
| D23  | 1   | 8640-202 | Cam                               |
| D24  |     |          | Removed 3/20/01                   |
| D25  | 1   | 8640-204 | Adjuster                          |
| D26  |     |          | Removed 3/20/01                   |
| D27  | 1   | 8640-206 | Leg                               |
| D28  | 1   | 8640-207 | Brace                             |
| D29  |     |          | Removed 3/20/01                   |
| D30B | 2   | 8640-347 | Insert                            |
| D31  | 1   | 8640-326 | Spacer Block                      |

| ITEM | QTY | PART NO. | DESCRIPTION                      |
|------|-----|----------|----------------------------------|
| D37  | 1   | HC702826 | SHCS .375-16 x 2.00              |
| D38  | 2   | HC702834 | SHCS .375-16 x 3.00              |
| D39  | 12  | HN704901 | Nylon Locknut .375-16            |
| D40  | 1   | JC702814 | SHCS .375-16 x .625              |
| D41  | 4   | JC702820 | SHCS .375-16 x 1.25              |
| D42  | 2   | JC702824 | SHCS .375-16 x 1.75              |
| D43  | 4   | JC702832 | SHCS .375-16 x 2.75              |
| D44  | 2   | JC702836 | SHCS .375-16 x 3.25              |
| D45  | 1   | JC702838 | SHCS .375-16 x 2.75              |
| D46  | 4   | PP080223 | Plastic Insert                   |
| D47  | 3   | PP090211 | Plastic Insert 1.50 Sq x 10-14 G |
| D49  | 1   | 4800-021 | Back Cushion                     |
| D50B | 1   | 4800-074 | Seat Cushion                     |
| D60  | 1   | 8640-211 | Cushion Bracket                  |
| D61  | 1   | 8640-212 | Cushion Post                     |
| D62  | 1   | 8640-214 | Leg Bar                          |
| D63  | 1   | 8640-334 | Support Plate                    |
| D65  | 2   | HS347700 | Washer                           |
| D69  | 6   | JS347400 | Internal Tooth Lockwasher        |

*This page intentionally left blank*

## Cables Adjustments

There are several cables utilized in the MG 500. The number of cables used in each station include:

- Fly Station - 3 cables
- Leg Press Station - 1 cable
- Leg Extension/Leg Curl Station - 2 cables
- Pressing Station - 2 cables

Adjust cables in order of station, starting with the Fly Station, then either the Leg Press Station or Leg Extension/Leg Curl Station (depending upon which configuration you have) and then the Pressing Station.

### Fly Station

1. **Check weight stack cable** (see step 1A).
  - A. See the general weight stack cable adjustment section on page 6-104.
2. **Check tension on next cable** (see steps 2A - and Figure 1).
  - A. Adjust hex nut to to remove any excess slack. See Figure 1.
  - B. If further adjustment is necessary, adjust cam bolt to remove excess slack.

**NOTE:** Pulley must be in the "V" slot and top weight plate must be just sitting on second weight plate.

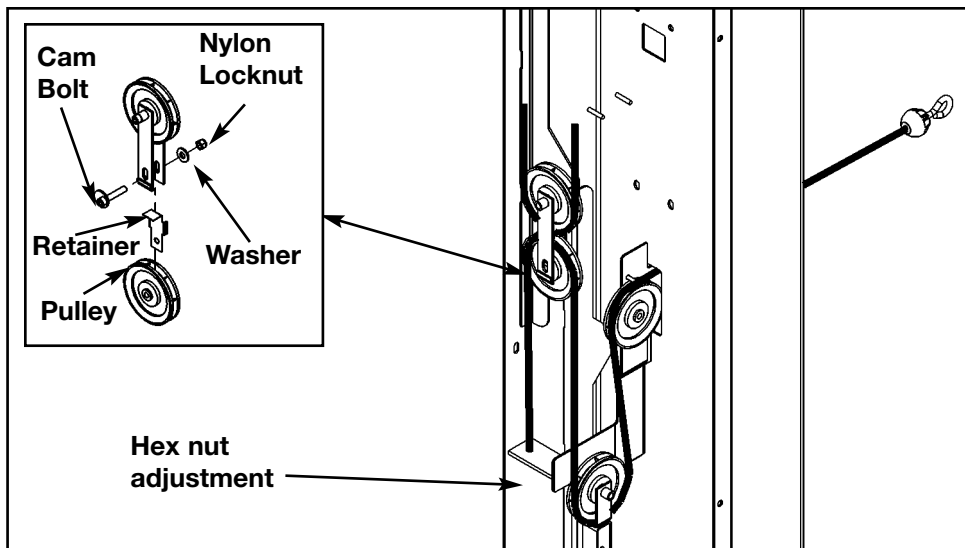

Figure 1

3. Check cam cable (see step 3A and Figure 2).

A. Adjust cam bolt (if necessary) to remove excess slack. See Figure 2.

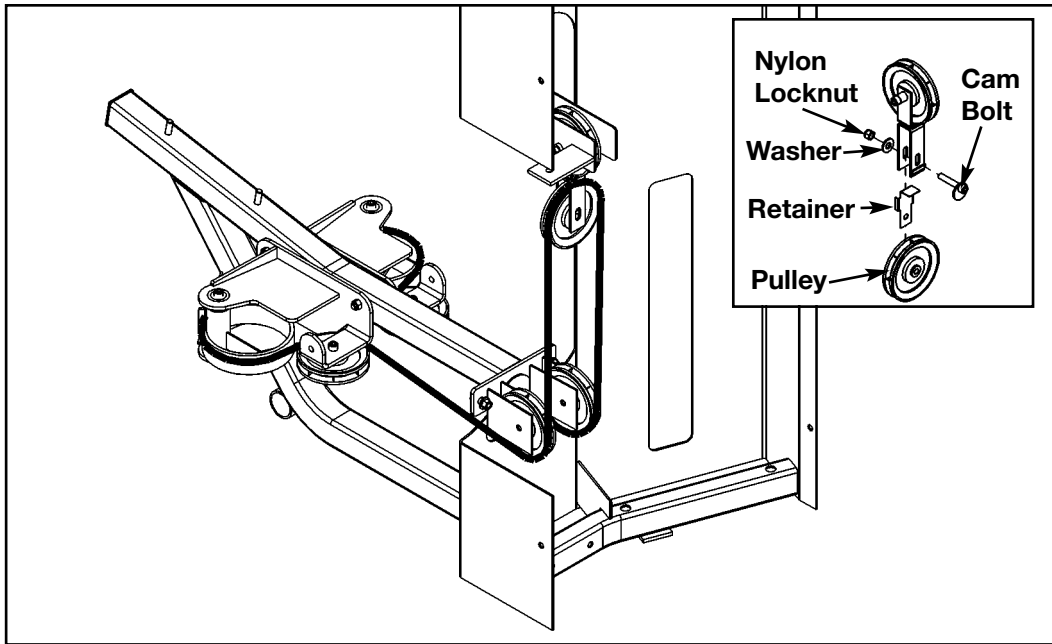

Figure 2

**Leg Press Station**

1. Check weight stack cable (see step 1A and Figure 3).

A. See the general weight stack cable adjustment section on page 6-96.

B. Adjust jam nut to remove slack. See Figure 1.

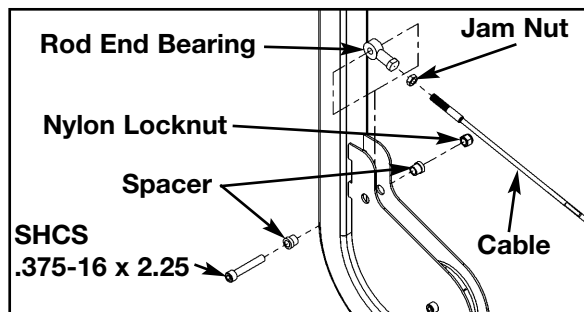

Figure 1

**Leg Extension/Leg Curl Station**

1. **Check weight stack cable** (see step 1A and Figure 1).
  - A. See the general weight stack cable adjustment section on page 6-92.
  - B. Adjust hex nut to remove slack.

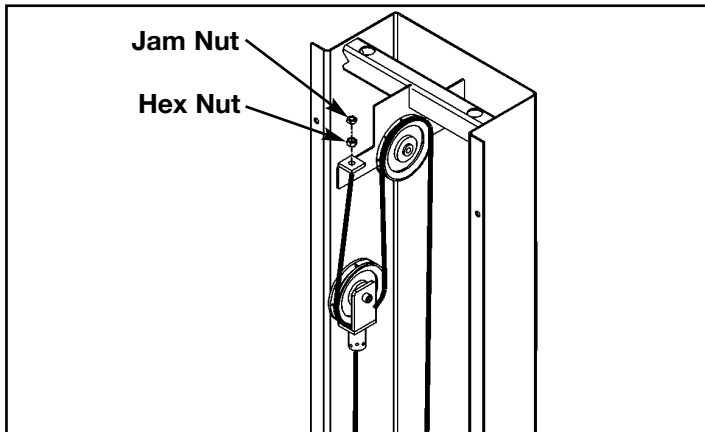

Figure 1

**Pressing Station**

1. **Check weight stack cable** (see step 1A and Figure 1).
  - A. See the weight stack check section on page 6-95.
  - B. Adjust hex nut to remove any slack.

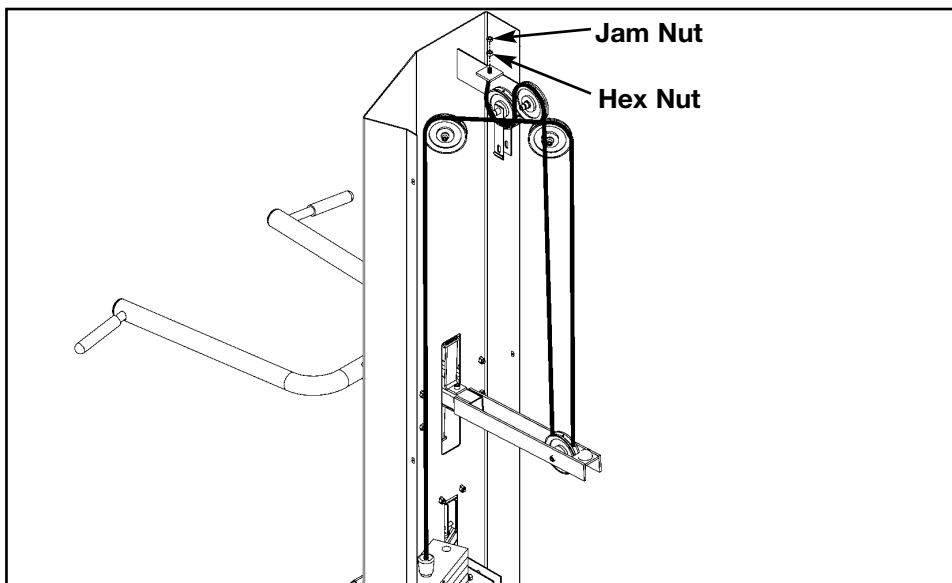

Figure 1

**2. Check tension on next cable** (see steps 2A and Figure 2).

**A.** Adjust cam bolt (if necessary) to remove excess slack. See Figure 2.

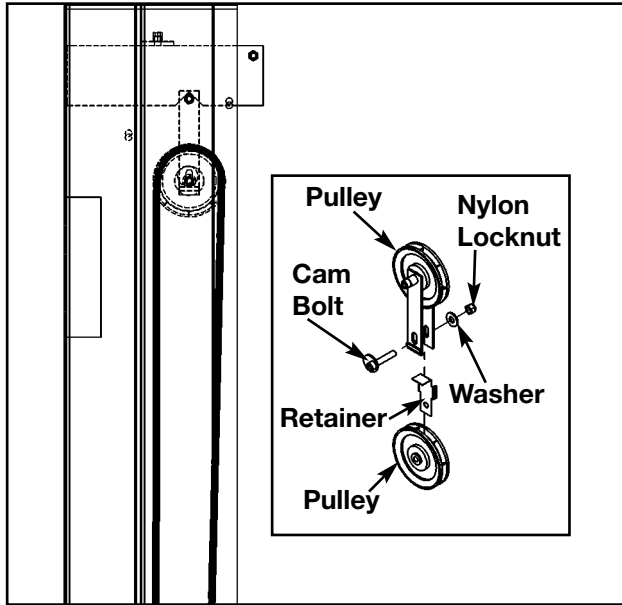

Figure 2

### Weight Stack Cable Check

#### 1. Check tension of weight stack cable.

**NOTE:** Assure top plate is flush with weight stack prior to and during cable tension check.

- A. Select a point on the cable half way between weight stack and pulley.

**NOTE:** Assure weight stack top plate is flush with weight stack prior to, and during, cable tension check.

- B. Push cable right or left. Cable deflection greater than 3/4" indicates excessive slack. Deflection of 1/4" to 3/4" is normal, as is a slight increase in slack between checks.

#### 2. Alternative Method - Check tension of weight stack cable.

- A. Select top weight plate (using weight selector pin).

- B. Slowly raise and lower top weight plate (in normal fashion).

- C. Verify top weight plate is just resting on second plate.

**NOTE (1):** If there is too much tension then the top weight plate will not properly rest on second weight and the weight stack selector pin may be difficult to insert into weight plates.

**NOTE (2):** Too much slack is indicated if top weight plate does not lift immediately after raising top weight plate (in normal fashion). A slight slack in cable is ok.

- D. Adjust cable if there is too much tension or too much slack. See **Cable Tension Adjustment** to adjust tension.

## Weight Stack Cable Adjustment

### Tools Required:

- 3/16" Punch
- Hammer

#### 1. Adjust top weight connector (see steps 1A - 1G).

- A.** Slide protective rubber cover up cable to expose cable/plate junction. Note spiral pin location in cable fitting. See Figure 1.

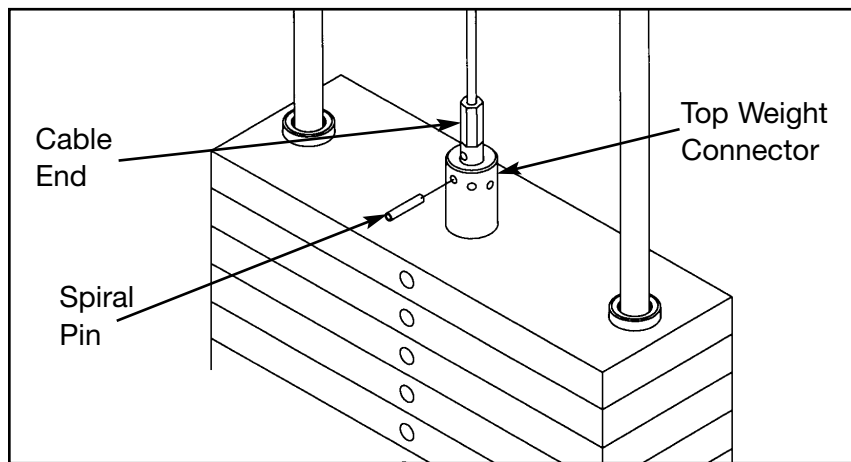

Figure 1

- B.** Using a 3/16" punch and hammer, drive spiral pin out of top plate connector and cable fitting.
- C.** Grip cable fitting firmly, pull down to tighten cable. Rotate fitting to align spiral pin hole with an opening in top plate connector.
- D.** Insert pin punch through top plate connector and spiral pin hole to hold cable in place.
- E.** Drive spiral pin through top plate connector and fitting from opposite side, pushing out pin punch. Assure spiral pin ends are flush.
- F.** Test cable tension (see Weight Stack Cable Tension Check). Deflection of 1/4" to 3/4" indicates proper tension. If top weight plate does not rest securely against the second plate and selector pin cannot be fully inserted, there is too much tension on the cable, fitting pin hole with another connector opening as required to adjust tension. Check that spiral pin is flush. If cable tension cannot be corrected, contact a Cybex Customer Relations Technician.
- G.** Once proper tension is achieved, fully inset selector pin and replace protective cover over cable fitting.

***Final Assembly***

- 1. Visual Inspection** (see steps 1A - 1C).
  - A.** Visually inspect the entire MG 500. Be sure cables are properly tensioned, hardware is secure and each station is correctly assembled.
  - B.** Place ankle strap, EZ curl handle and handle sub-assembly on or near the Pressing station.
  - C.** Place pulldown bar and ab crunch strap on or near the Fly Station.
- 2. Replace braces and back covers** (See Steps 2A - 2B).
  - A.** Install all three braces. See Figure 2 on page 6-4.
  - B.** Install back covers. See Figure 1 on page 6-3.
- 3. Functional Inspection** (see step 3A).
  - A.** Check for proper operation of each station.

*This page intentionally left blank*

## 7 - Maintenance

All preventive maintenance activities must be performed on a regular basis. Performing routine preventive maintenance actions can aid in providing safe, trouble-free operation of your Cybox MG 500.

**NOTE:** *Cybox is not responsible for performing regular inspection and maintenance actions for your machines. Instruct all personnel in equipment inspection and maintenance actions and also in accident reporting/recording. Cybox phone representatives are available to answer any questions or concerns that you may have.*



**NOTE:** *All inspections and repairs must be performed by trained service personnel only.*

**Cybox will void warranty if non-Cybox replacement parts are used.**

### **Daily Procedures**

1. **Upholstery** - Wipe down all upholstery as per the recommendations listed below for light soiling and more difficult stains.

#### *Light Soiling*

- A solution of 10% household liquid dish soap with warm water applied with a soft damp cloth.
- If necessary, a solution of liquid cleanser and water applied with a soft bristle brush. Wipe away the residue with a water dampened cloth.

*More Difficult Stains*

- Dampen a soft white cloth with a solution of household bleach (sodium hypochlorite), 10 % bleach, 90% water. Rub gently. Rinse with a water dampened cloth to remove bleach concentration.
- The same procedure can be used with full strength household bleach, if necessary.
- Allow bleach to puddle on the affected area or apply with a soaked cloth for approximately 30 minutes. Rinse with a water dampened cloth to remove any remaining bleach concentration.

*Alternative Method for Difficult Stains*

- Dampen a soft white cloth with rubbing alcohol and rub gently. Rinse with a water dampened cloth to remove any remaining rubbing alcohol concentration.

**NOTE:** *To restore luster, a light coat of spray furniture wax can be used. Apply for 30 seconds and follow with a light buffing using a clean white cloth.*

***Please Review Carefully***

When using strong cleaning agents such as rubbing alcohol or bleach, it is advisable to first test in an inconspicuous area. Other cleaning agents may contain harsh or unknown solvents and are subject to formula changes by the product manufacturer without notice. Should you desire to use other cleaning agents, carefully try them in an inconspicuous area to determine potential damage to the material. Never use harsh solvents or cleaners which are intended for industrial applications. To clean stained or soiled areas, a soft white cloth is recommended. Avoid use of paper towels.

Cleaning products may be harmful/irritating to your skin, eyes, etc. Use protective gloves and eye protection. Do not inhale or swallow any cleaning product. Protect surrounding area/clothing from exposure. Use in a well ventilated area. Follow all product manufacturer's warnings. Cybex and its vendors cannot be held responsible for damage or injuries resulting from the use or misuse of cleaning products.

- 2. Frames** - Wipe down all frames using a mild solution of warm water and car wash soap. Be sure to dry thoroughly. **AVOID** acid or chlorine based cleaners and also cleaners containing abrasives as these could scratch or damage the equipment.
- 3. Chrome** - Clean chrome tubes, first using chrome polish and then using a car wax seal. Neutral cleaners with a pH between 5.5 and 8.5 are recommended. Be sure to dry thoroughly. **AVOID** acid or chlorine based cleaners and also cleaners containing abrasives as these could scratch or damage the equipment.

**Weekly Procedures**

1. Inspect all nuts and bolts for looseness. Tighten as required.
2. Inspect all cables for wear or damage and proper tension. When inspecting cables, run your fingers on the cable, paying particular attention to bends in the cable and attachment points.

**! WARNING: Replace all worn cables immediately. The following conditions may indicate a worn cable:**

- A tear or crack in the cable sheath that exposes the cable. See Figure 1.

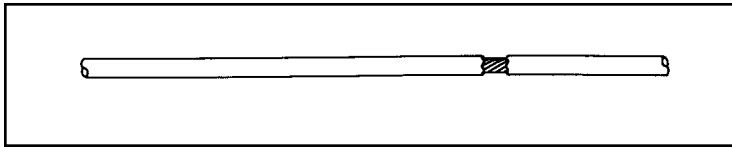

Figure 1

- A kink in the cable. See Figure 2.

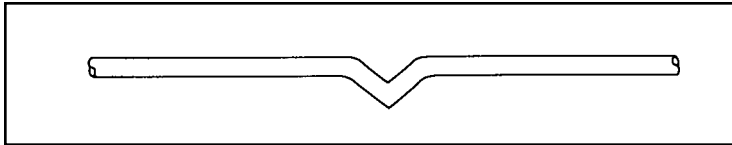

Figure 2

- A curled sheath. See Figure 3.

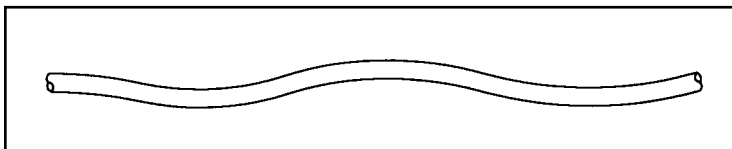

Figure 3

- "Necking", a stretched cable sheath. See Figure 4.

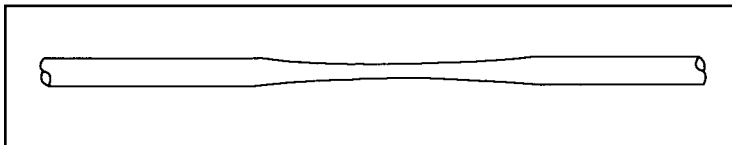

Figure 4

3. Inspect bars and handles for wear, paying particular attention to tab area connecting points.

**Replace all worn handles immediately.**

***! CAUTION: Replace all worn handles immediately. Do not use if less than 1/8" of material remains to the edge. See Figure 5.***

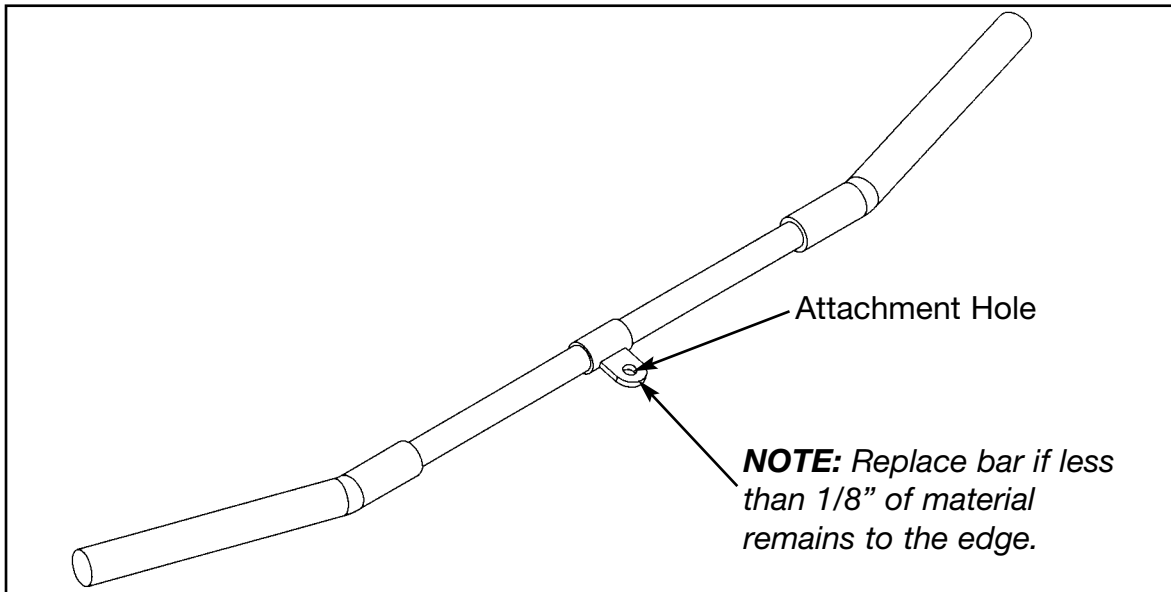

Figure 5

4. Inspect snap links for proper latching (indicates wear). Replace all worn snap links immediately.
5. Inspect all labeling for readability. This includes instructional placards, warning and caution decals. Replace all warning labeling immediately.
6. Inspect all weight stacks for proper alignment and operation.

***NOTE: Correct all improper alignment and operation issues immediately.***

7. Wipe Weight Stack Guide Rods and Leg Press Linear bearings clean over entire length. Lubricate with a light coat of medium weight automotive engine oil.

### ***Yearly Procedures***

Replace all cables at least annually.

### ***"As Required" Procedures***

Inspect grips and replace as necessary.

### ***Cables Adjustments***

There are several cables utilized in the MG 500. The number of cables used in each station include:

- Fly Station - 3 cables
- Leg Press Station - 1 cable
- Leg Extension/Leg Curl Station - 2 cables
- Pressing Station - 2 cables

Adjust cables in order of station, starting with the Fly Station, then either the Leg Press Station or Leg Extension/Leg Curl Station (depending upon which configuration you have) and then the Pressing Station.

**Fly Station**

**1. Check weight stack cable** (see step 1A).

**A.** See the general weight stack cable adjustment section on page 6-95.

**2. Check tension on next cable** (see steps 2A - and Figure 1).

**A.** Adjust hex nut to to remove any excess slack. See Figure 1.

**B.** If further adjustment is necessary, adjust cam bolt to remove excess slack.

**NOTE:** Pulley must be in the "V" slot and top weight plate must be just sitting on second weight plate.

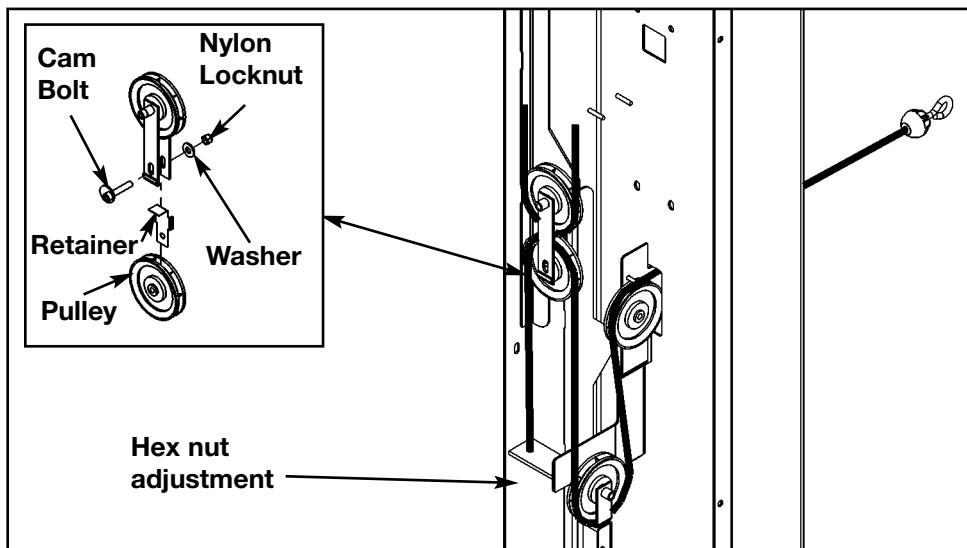

Figure 1

**3. Check cam cable** (see step 3A and Figure 2).

**A.** Adjust cam bolt (if necessary) to remove excess slack. See Figure 2.

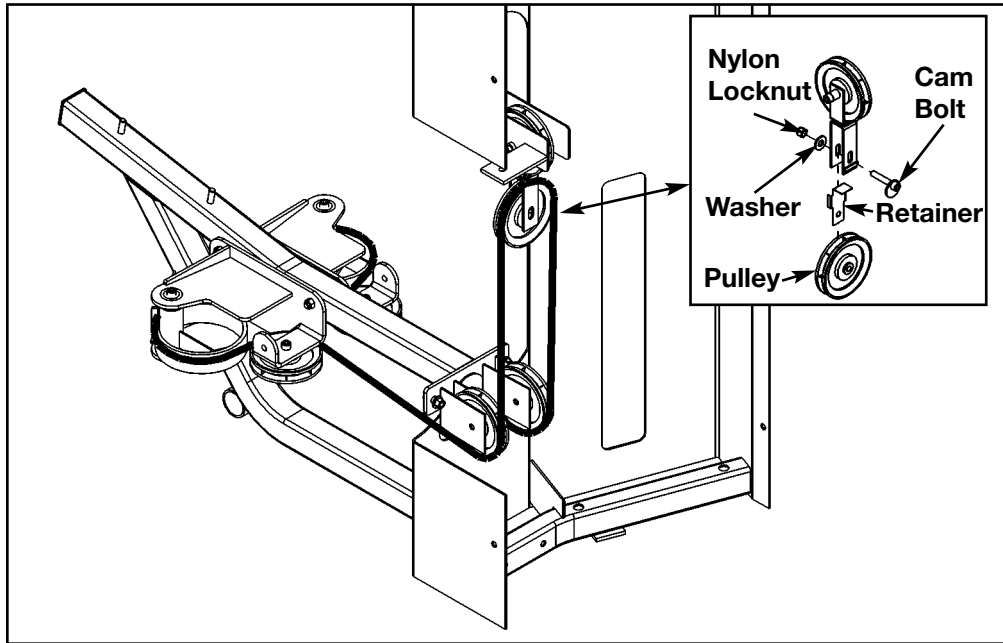

Figure 2

**Leg Press Station**

**1. Check weight stack cable** (see step 1A and Figure 1).

**A.** See the general weight stack cable adjustment section on page 6-96.

**B.** Adjust jam nut to remove slack. See Figure 1.

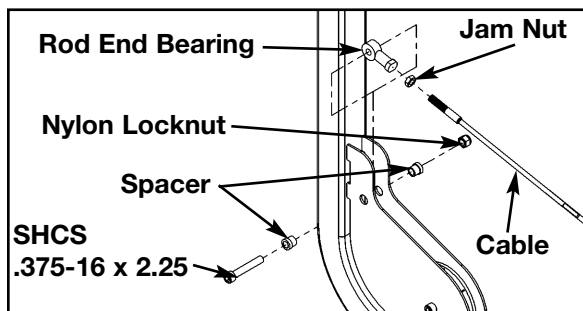

Figure 1

**Leg Extension/Leg Curl Station**

1. **Check weight stack cable** (see step 1A and Figure 1).
  - A. See the general weight stack cable adjustment section on page 6-92.
  - B. Adjust hex nut to remove slack.

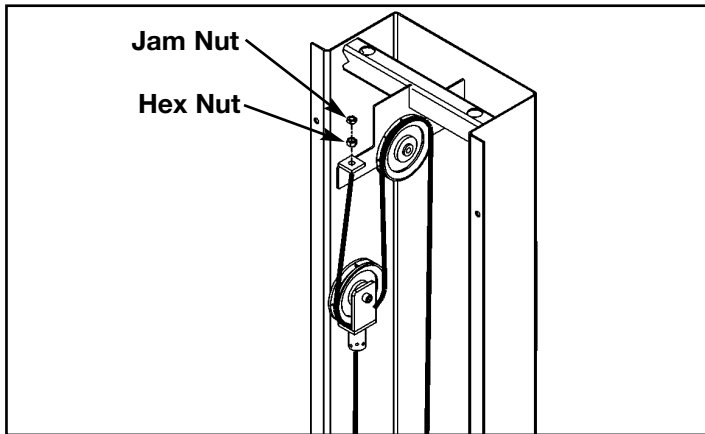

Figure 1

**Pressing Station**

1. **Check weight stack cable** (see step 1A and Figure 1).
  - A. See the weight stack check section on page 6-95.
  - B. Adjust hex nut to remove any slack.

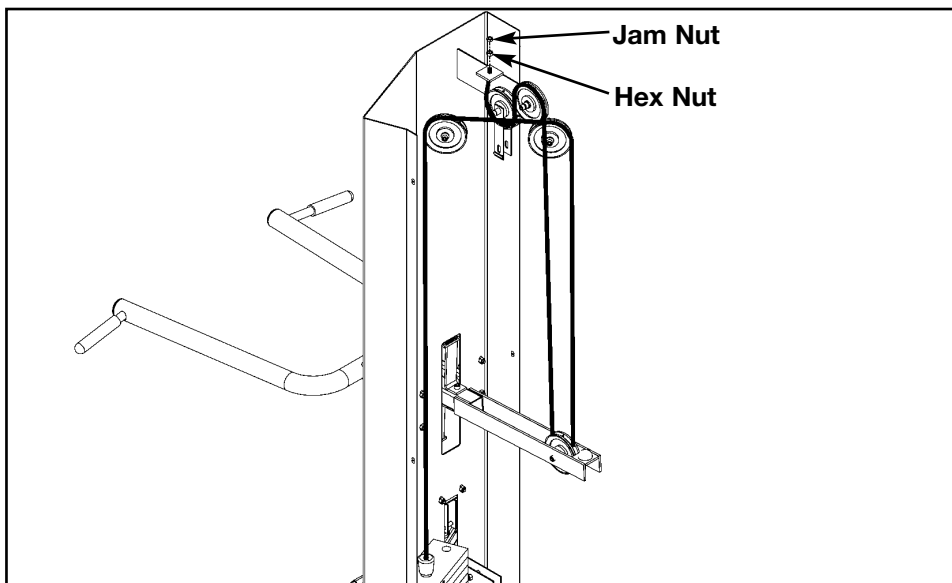

Figure 1

**2. Check tension on next cable** (see steps 2A and Figure 2).

**A.** Adjust cam bolt (if necessary) to remove excess slack. See Figure 2.

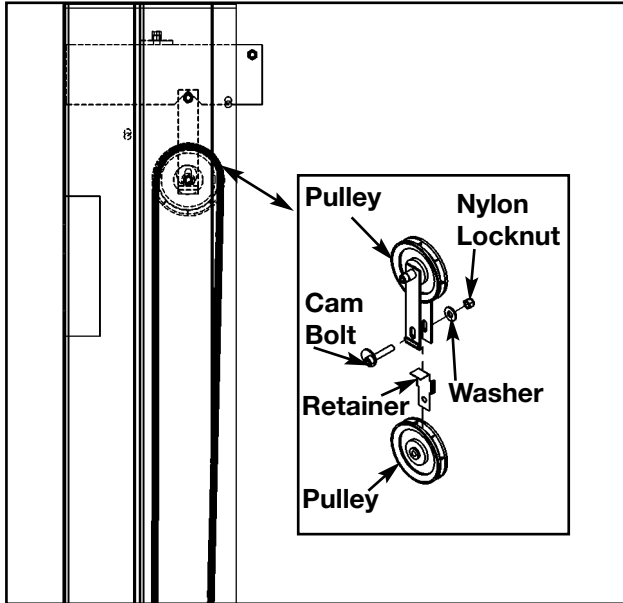

Figure 2

### **Weight Stack Cable Tension Check**

**NOTE:** Assure weight stack top plate is flush with weight stack prior to, and during, cable tension check.

1. Select a point on the cable half way between weight stack and pulley.
2. Push cable right or left. Cable deflection greater than 3/4" indicates excessive slack. Deflection of 1/4" to 3/4" is normal, as is a slight increase in slack between checks. See Cable Tension Adjustment to adjust tension.

### **Alternative Weight Stack Cable Tension Check**

1. Select top weight plate (using weight selector pin).
2. Slowly raise and lower top weight plate (in normal fashion).
3. Verify top weight plate is just resting on second plate.

**NOTE:** If there is too much tension then the top weight plate will not properly rest on second weight and the weight stack selector pin may be difficult to insert into weight plates.

**NOTE:** Too much slack is indicated if top weight plate does not lift immediately after raising top weight plate (in normal fashion). A slight slack in cable is ok.

4. Adjust cable if there is too much tension or too much slack. See Cable Tension Adjustment to adjust tension.

## Weight Stack Cable Adjustment

### Tools Required:

- 3/16" Punch
- Hammer

1. Slide protective rubber cover up cable to expose cable/plate junction. Note roll pin location in cable fitting. See Figure 8.

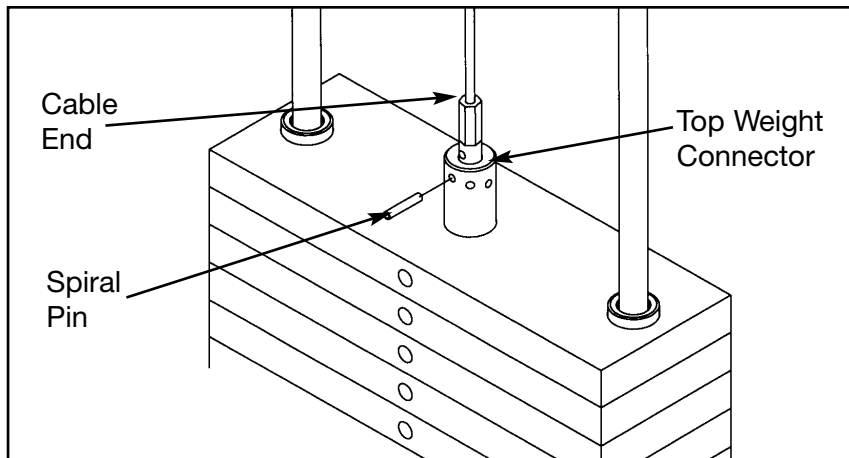

Figure 8

2. Using a 3/16" pin punch and hammer, drive spiral pin out of top plate connector and cable fitting.
3. Grip cable fitting firmly, pull down to tighten cable. Rotate fitting to align spiral pin hole with an opening in top plate connector.
4. Insert pin punch through top plate connector and spiral pin hole to hold cable in place.
5. Drive spiral pin through top plate connector and fitting from opposite side, pushing out pin punch. Assure spiral pin ends are flush.
6. Test cable tension (see Weight Stack Cable Tension Check). Deflection of 1/4" to 3/4" indicates proper tension. If top weight plate does not rest securely against the second plate and selector pin cannot be fully inserted, there is too much tension on the cable, fitting pin hole with another connector opening as required to adjust tension. Check that spiral pin is flush. If cable tension cannot be corrected, contact a Cybex Customer Relations Technician.
7. Once proper tension is achieved, fully inset selector pin and replace protective cover over cable fitting.

***This page intentionally left blank***

## 8 - Service

Please refer to the next several pages for parts lists, exploded-view diagrams and cable routing diagrams.



***NOTE:** All inspections and repairs must be performed by trained service personnel only.*

**Cybex will void warranty if non-Cybex replacement parts are used.**

**8610 - Pressing Station**

| ITEM | QTY | PART NO.  | DESCRIPTION                      |
|------|-----|-----------|----------------------------------|
| A1   | 2   | 01190     | Vinyl Black End Cap              |
| A2   | 4   | 02205     | Foam Grip 10.00                  |
| A3   | 2   | 08009     | Flange Bearing .50 x .62 x .50 L |
| A4   | 4   | 08014     | Pulley                           |
| A5   | 2   | 11040-440 | Cybex Knob                       |
| A6   |     |           | Removed                          |
| A7   | 2   | 4005M100  | Foam Grip 6.00                   |
| A8   | 1   | 4800-019  | Seat Cushion                     |
| A9   | 1   | 4800-009  | Back Cushion                     |
| A10  | 1   | 8510-304  | Cushion Plate                    |
| A11  | 2   | 8510-330  | Lexan Washer                     |
| A12  | 2   | 8510-343  | Non-Slip                         |
| A13  | 2   | 8510-344  | Rubber Cap                       |
| A14  | 2   | 8510-364  | Notched Plastic Insert           |
| A15  | 2   | 8510-366  | Detent Pin                       |
| A16  | 1   | 8610-308  | Shaft                            |
| A17  | 1   | 8610-203  | Brace                            |
| A18  | 1   | 8610-204  | Platform                         |
| A19  | 1   | 8610-201  | Pressing Arm                     |
| A20  | 1   | 8610-207  | Leg                              |
| A21  | 1   | 8610-210  | Frame                            |
| A22  | 1   | 8610-205  | Swivel Pulley Bracket            |
| A23  | 1   | 8510-208  | Cushion Plate                    |
| A24  | 1   | 8610-202  | Pivot Arm                        |
| A25  | 1   | 8510-210  | Detent Plate                     |
| A26  | 2   | GQ000206  | Snap Link                        |
| A27  | 2   | HB-60652  | Pillow Block Bearing             |
| A28  | 2   | HC702815  | SHCS .375-16 x .750              |
| A29  | 4   | HC702816  | SHCS .375-16 x .875              |
| A30  | 1   | HC702830  | SHCS .375-16 x 2.50              |
| A31  | 4   | HC702834  | SHCS .375-16 x 3.00              |
| A32  | 1   | HS347600  | Washer, SAE .375                 |

| ITEM | QTY | PART NO. | DESCRIPTION                         |
|------|-----|----------|-------------------------------------|
| A33  | 1   | HS-60546 | HHCS Bolt .375 x 5.00               |
| A34  | 2   | PN660200 | Plastic Insert 1.00 Dia. x 11 G     |
| A35  | 3   | PP090210 | Plastic Insert 2.00 Sq x 10-14 G    |
| A36  | 2   | PP080224 | Plastic Inset 2.00 Dia.             |
| A37  | 3   | PP090205 | Plastic Insert 1.00 x 2.00 x 11 G   |
| A38  | 19  | HN704901 | Nylon Locknut, .375-16              |
| A39  | 6   | JC702820 | SHCS .375-16 x 1.25                 |
| A40  | 2   | JC702824 | SHCS .375-16 x 1.75                 |
| A41  | 2   | JC702832 | SHCS .375-16 x 2.75                 |
| A42  | 1   | 51081    | Handle                              |
| A43  | 1   | HC702817 | SHCS .375-16 x 1.00                 |
| A44  | 1   | 4505-331 | Bumper                              |
| A45  | 1   | 8500-028 | Caution Decal                       |
| A46  | 1   | 8500-311 | Warning Decal                       |
| A47  | 1   | 8500-318 | Adjustment Decal                    |
| A48  | 1   | 8500-319 | Adjustment Decal                    |
| A49  | 1   | 8610-002 | Cable 179.25 L                      |
| A50  | 1   | 8610-003 | Cable 173.44 L                      |
| A51  | 2   | BS070201 | Com Spring                          |
| A52  | 1   | JC702814 | SHCS .375-16 x .625                 |
| A53  | 1   | HN704000 | Hex Nut .375-16                     |
| A54  | 1   | HN704400 | Jam Nut .375-16                     |
| A55  | 1   | 51122    | Ankle Strap                         |
| A56  | 2   | 5310S040 | Handle Sub-Assembly                 |
| A57  | 1   | 8500-202 | EZ Curl Handle                      |
| A58  | 1   | 4800-381 | Warning Decal                       |
| A59  | 1   | 8610-598 | Placard Decal                       |
| A60  | 1   | 3900-391 | Cybex Decal 11.37 Vert. Wht/Wht     |
| A61  | 2   | 8610-330 | Formed Guard                        |
| A62  | 5   | JS347400 | Internal Tooth Lockwasher           |
| A63  | 1   | 51198    | Strength Warranty Sheet (not shown) |

# 8610 - Pressing Station

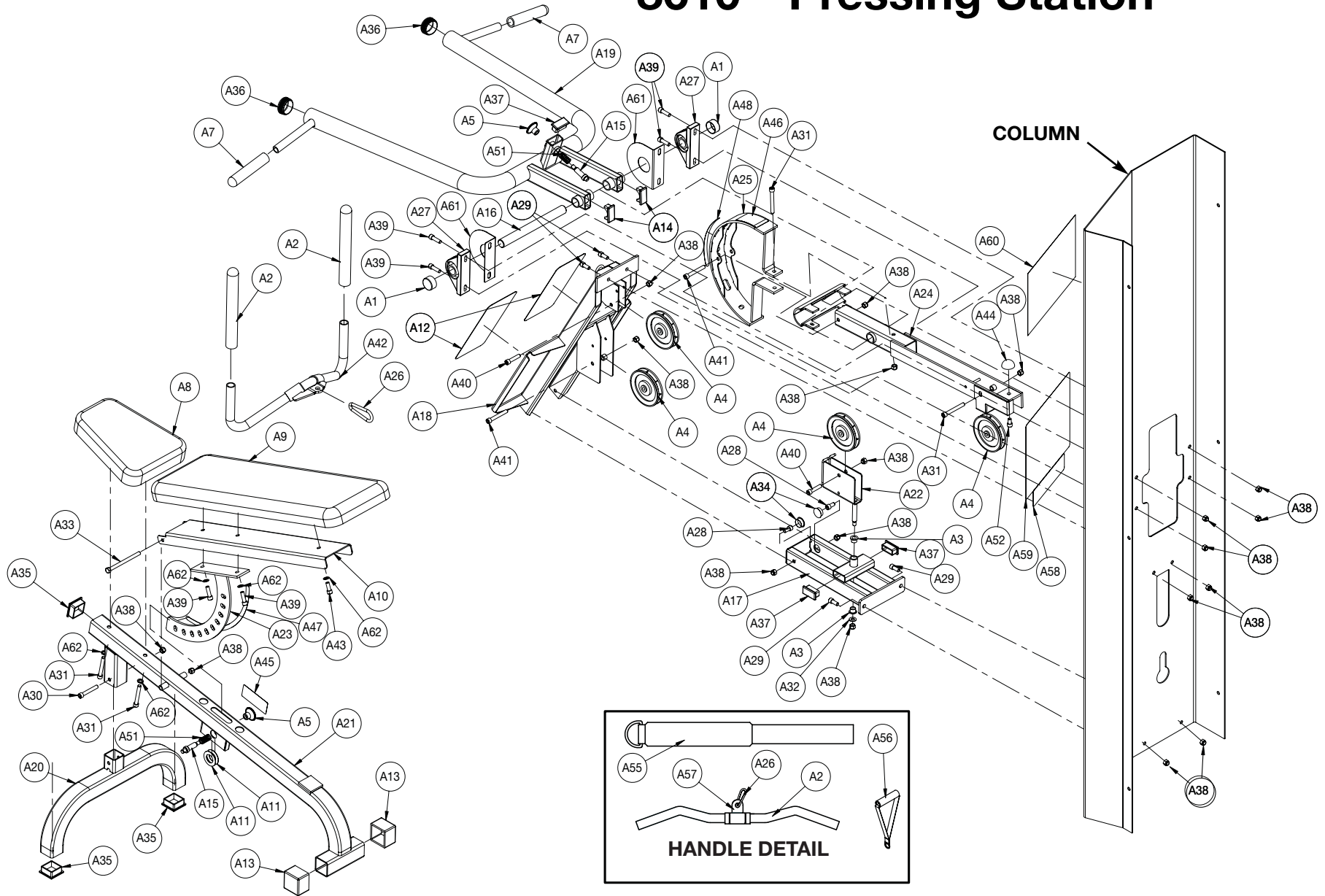

**8620 - Fly Station**

| ITEM | QTY | PART NO.   | DESCRIPTION                        |
|------|-----|------------|------------------------------------|
| B1   | 3   | 08014      | Pulley                             |
| B2   | 4   | 08135      | Ball Bearing                       |
| B3   | 1   | 11040-440  | Cybox Knob                         |
| B4   | 1   | 08229      | Detent Pin                         |
| B5   | 1   | 4035S121-0 | Cushion                            |
| B6   | 1   | 4106S055-0 | Seat Cushion                       |
| B7   | 1   | 4605-511   | Plastic Insert 5.94                |
| B8   | 1   | 5245-011   | Cushion                            |
| B9   | 2   | 8500-052   | Cushion                            |
| B10  | 1   | 8500-025   | Caution Decal                      |
| B11  | 2   | 8500-026   | Caution Decal                      |
| B12  | 2   | 8520-212   | Handle                             |
| B13  | 2   | 8520-307   | Hand Grip 5.125 L                  |
| B14  | 2   | 8520-320   | Rod Handle Grip                    |
| B15  | 2   | 8520-346   | Detent Pin                         |
| B16  | 1   | 8620-200   | Frame                              |
| B17  | 1   | 8620-201   | Hip Support                        |
| B18  | 1   | 8620-202   | Cushion Tube                       |
| B19  | 1   | 8620-203   | Right Pivot                        |
| B20  | 1   | 8620-204   | Left Pivot                         |
| B21  | 1   | 8620-207   | Right Hand Pivot Handle            |
| B22  | 1   | 8620-208   | Left Hand Pivot Handle             |
| B23  | 1   | 8620-209   | Right Arm                          |
| B24  | 1   | 8620-210   | Left Arm                           |
| B25  | 1   | 8620-211   | Boom                               |
| B26  | 1   | 8620-214   | Hook                               |
| B27  | 2   | 8620-342   | HHCS 10 mm x 120 mm                |
| B28  | 4   | FB050226   | Flanged Bearing 1.00 x 1.25 1.00 L |
| B29  | 4   | FB130212   | Flange Bushing .75 ID              |
| B30  | 1   | HP707017   | Stud .375-16 x 1.00                |
| B31  | 4   | HC702816   | SHCS .375-16 x .875                |
| B32  | 4   | HC702817   | SHCS .375-16 x 1.00                |
| B33  | 3   | HC702826   | SHCS .375-16 x 2.00                |
| B34  | 5   | HC702834   | SHCS .375-16 x 3.00                |
| B35  | 14  | HN704901   | Nylon Locknut .375-16              |
| B36  | 4   | HS347600   | Washer, SAE .375                   |

| ITEM | QTY | PART NO. | DESCRIPTION                      |
|------|-----|----------|----------------------------------|
| B37  | 2   | HW-60085 | Washer .3125                     |
| B38  | 4   | JC702814 | SHCS .375-16 x .625              |
| B39  | 2   | JC702820 | SHCS .375-16 x 1.25              |
| B40  |     |          | Removed (11/02)                  |
| B41  | 2   | PL-52062 | Bumper 2.00 Dia. x .625          |
| B42  | 2   | PP080223 | Plastic Insert                   |
| B43  | 1   | PP090210 | Plastic Insert 2.00 Sq x 10-14 G |
| B44  | 1   | PP090211 | Plastic Insert 1.50 Sq x 10-14 G |
| B45  | 2   | PP460202 | Plastic Knob .164 8-32 x .59     |
| B46  | 2   | HC702822 | SHCS .375-16 x 1.50              |
| B47  | 1   | 8520-313 | Seat Adjusting Decal             |
| B48  | 2   | BS070207 | Com Spring .19 x .24 .38 L       |
| B49  | 1   | BS070201 | Com Spring .56 x .66 1.50 L      |
| B50  | 1   | 4505-331 | Bumper 1.50 Dia.                 |
| B51  | 1   | 8500-201 | Pulldown Bar                     |
| B52  | 1   | 8620-002 | Cable 151.12 L                   |
| B53  | 1   | 8620-003 | Cable 65.97 L                    |
| B54  | 1   | 8620-004 | Cable 106.25 L                   |
| B55  | 2   | 8620-336 | Hand Grip 5.00 L                 |
| B56  | 2   | 8620-337 | Spacer                           |
| B57  | 1   | 8620-338 | Ab Crunch Tricep Strap           |
| B58  | 1   | 8620-341 | Guard                            |
| B59  | 2   | 8630-336 | Nylon Locknut 10 mm              |
| B60  | 2   | PR400201 | Grip                             |
| B61  | 2   | GQ000206 | Snap Link                        |
| B62  | 5   | HC702815 | SHCS .375-16 x 7.50              |
| B63  | 1   | HN704400 | Jam Nut .375-16                  |
| B64  | 1   | HN704000 | Hex Nut .375-16                  |
| B65  | 1   | 8620-598 | Placard Decal                    |
| B66  | 1   | 3900-391 | Cybox Decal 11.37 Vert. Wht/Wht  |
| B67  | 1   | 4800-381 | Warning Decal                    |
| B68  | 2   | 8620-343 | Warning Decal                    |
| B69  | 2   | 5340Y045 | Arrow Decal                      |
| B70  | 2   | 8620-344 | Pivot Guard                      |
| B71  | 1   | 8620-215 | Bracket                          |
| B72  | 6   | JS347400 | Internal Tooth Lockwasher        |



**8630 - Leg Press Station**

| ITEM | QTY | PART NO.   | DESCRIPTION                           |
|------|-----|------------|---------------------------------------|
| C1   | 3   | 08014      | Pulley                                |
| C2   | 10  | FB030242   | Bearing with snap ring, 30 mm x 10 mm |
| C3   | 1   | 08172      | Cybex Knob                            |
| C4   | 1   | 4000Y316   | Caution Decal                         |
| C5   | 2   | 4005M100   | Grip                                  |
| C6   | 1   | 4106S055-0 | Back Cushion                          |
| C7   | 1   | 4505-329   | Detent Pin                            |
| C8   | 1   | 4605-511   | Plastic Insert 5.94                   |
| C9   | 1   | 4800-026   | Bottom Cushion                        |
| C10  | 2   | 4800-570   | Cable Guard                           |
| C11  | 1   | 8500-025   | Caution Decal                         |
| C12  | 1   | 8520-313   | Seat Adjusting Decal                  |
| C13  |     |            | Removed                               |
| C14  | 1   | 8630-200   | Frame                                 |
| C15  | 1   | 8630-201   | Seat Frame                            |
| C16  | 1   | 8630-202   | Seat Tube                             |
| C17  | 1   | 8630-203   | Right Foot Plate                      |
| C18  | 1   | 8630-204   | Left Foot Plate                       |
| C19  | 1   | 8630-205   | Roller Tube                           |
| C20  | 1   | 8630-206   | Roller Plate                          |
| C21  | 1   | 8630-207   | Right Handle                          |
| C22  | 1   | 8630-208   | Left Handle                           |
| C23  | 1   | 8630-209   | Pivot Tube                            |
| C24  | 1   | 8630-210   | Connector                             |
| C25  | 2   | 8630-321   | Non-Slip                              |
| C26  | 2   | 8630-322   | Roller                                |
| C27  | 1   | 8630-326   | Plastic Seat Sleeve                   |
| C28  | 2   | 8630-331   | Spacer                                |
| C29  | 4   | JC702820   | SHCS .375-16 x 1.25                   |

| ITEM | QTY | PART NO. | DESCRIPTION                       |
|------|-----|----------|-----------------------------------|
| C30  | 3   | 8630-336 | Nylon Locknut, 10 mm              |
| C31  | 1   | HC702816 | SHCS .375-16 x .875               |
| C32  | 4   | HC702834 | SHCS .375-16 x 3.00               |
| C33  | 20  | HN704901 | Nylon Locknut, .375-16            |
| C34  | 1   | JC702814 | SHCS .375-16 x .625               |
| C35  | 3   | JC702824 | SHCS .375-16 x 1.75               |
| C36  | 4   | JC702832 | SHCS .375-16 x 2.75               |
| C37  |     |          | Removed                           |
| C38  | 2   | PP090000 | Plastic Insert 1.50 x 2.00 x 11 G |
| C39  | 1   | PP090200 | Plastic Insert 1.75 Sq x 10-14 G  |
| C40  | 2   | PP090210 | Plastic Insert 2.00 Sq x 11 G     |
| C41  | 1   | PP090211 | Plastic Insert 1.50 Sq x 10-14 G  |
| C42  | 1   | PU060201 | Bumper                            |
| C43  | 3   | HC331271 | HHCS 10 mm x 110 mm               |
| C44  | 2   | PP080225 | Plastic Insert 1.50 x 2.00 11 G   |
| C45  | 1   | BS070201 | Com Spring .56 x .66 1.50 L       |
| C46  | 1   | 8630-002 | Cable 216.50 L                    |
| C47  | 2   | 8630-340 | Spacer                            |
| C48  | 1   | FB030213 | Rod End Bearing                   |
| C49  | 1   | HC702828 | SCHS .375-16 x 2.25               |
| C50  | 2   | JC700917 | FHSCS .375-16 x 1.00              |
| C51  | 4   | JC702836 | SHCS .375-16 x 3.25               |
| C52  | 1   | JN714400 | Jam Nut .375-24 UNF               |
| C53  | 1   | 8630-598 | Placard Decal                     |
| C54  | 1   | 3900-391 | Cybex Decal 11.37 Vert. Wht/Wht   |
| C55  | 1   | 4800-381 | Warning Decal                     |
| C56  | 1   | CM000211 | Patent Pending Decal              |
| C57  | 8   | JS347400 | Internal Tooth Lockwasher         |



**Cybox MG 500 Multi-Gym Owner's Manual**  
**8640 - Leg Extension/Leg Curl Station**

| ITEM | QTY | PART NO.  | DESCRIPTION  |
|------|-----|-----------|--|
| D1   | 4   | 08014     | Pulley   |
| D2   | 2   | FB030242  | Bearing with snap ring 30 mm x 10 mm                               |
| D3   |     |           | Removed 3/20/01  |
| D4   | 4   | 11040-440 | Cybox Knob   |
| D5   | 2   | 4050M025  | Grip   |
| D6   | 3   | 4505-329  | Detent Pin   |
| D7   | 2   | 4605-511  | Plastic Insert 5.94  |
| D8   | 2   | 4800-570  | Cable Guard  |
| D9   | 1   | 4850-202  | Right Handle   |
| D10  | 1   | 4850-203  | Left Handle  |
| D11  | 4   | 8500-025  | Caution Decal  |
| D12  | 2   | 8500-026  | Caution Decal  |
| D13  | 4   | 8500-052  | Cushion 4.00 Dia. x 7.00 L x .875                                  |
| D14  | 1   | 8520-308  | Leg Curl Tube  |
| D15  | 1   | 8520-313  | Seat Adjusting Decal   |
| D16  |     |           | Removed 7/13/01  |
| D17A | 1   | 8630-335  | HHCS 10 mm x 100 mm (units with serial number before 8650NVXXXX13) |
| D17B | 1   | 8640-345  | HHCS 10 mm x 80 mm (units with serial number after 8650NVXXXX13)   |
| D17C | 1   | HC331269  | HHCS 10 mm x 90 mm (units with serial number after 8650NV031928)   |
| D18  | 1   | 8630-336  | Nylon Locknut 10 mm  |
| D19  | 1   | 8640-002  | Cable 132.12 L   |
| D20  | 1   | 8640-003  | Cable 83.49 L  |
| D21A | 1   | 8640-200  | Frame (units with serial number before 8650NVXXXX13)               |
| D21B | 1   | 8640-213  | Frame (units with serial number after 8650NVXXXX13)                |
| D22  | 1   | 8640-201  | Cushion Post (for Back Cusion)                                     |
| D23  | 1   | 8640-202  | Cam  |
| D24  |     |           | Removed 3/20/01  |
| D25  | 1   | 8640-204  | Adjuster   |
| D26  |     |           | Removed 3/20/01  |
| D27  | 1   | 8640-206  | Leg  |
| D28  | 1   | 8640-207  | Brace  |
| D29  |     |           | Removed 3/20/01  |
| D30A | 2   | 8640-321  | Insert (units with serial number before 8650NVXXXX13)              |
| D30B | 2   | 8640-347  | Insert (units with serial number after 8650NVXXXX13)               |
| D31  |     |           | Removed 3/20/01  |
| D32  | 4   | BS070201  | Com Spring .56 x .66 1.50 L  |
| D33  | 2   | FB050211  | Bearing Flange .38 x .50 .25 L                                     |

| ITEM | QTY | PART NO. | DESCRIPTION   |
|------|-----|----------|---|
| D34  | 2   | FB050226 | Flange Bearing<br>1.00 ID x 1.25 OD x 1.00 L                |
| D35  | 4   | FB130205 | Flange Bearing .62 x .75 x .38 L                            |
| D36  | 1   | 4507-301 | Pin   |
| D37  | 2   | HC702826 | SHCS .375-16 x 2.00   |
| D38  | 2   | HC702834 | SHCS .375-16 x 3.00   |
| D39  | 12  | HN704901 | Nylon Locknut .375-16                                       |
| D40  | 1   | JC702814 | SHCS .375-16 x .625   |
| D41  | 4   | JC702820 | SHCS .375-16 x 1.25   |
| D42  | 2   | JC702824 | SHCS .375-16 x 1.75   |
| D43  | 4   | JC702832 | SHCS .375-16 x 2.75   |
| D44  | 2   | JC702836 | SHCS .375-16 x 3.25   |
| D45  | 1   | JC702838 | SHCS .375-16 x 3.50   |
| D46  | 4   | PP080223 | Plastic Insert  |
| D47  | 3   | PP090211 | Plastic Insert 1.50 Sq x 10-14 G                            |
| D48  | 1   | PU060201 | Bumper  |
| D49  | 1   | 4800-021 | Back Cushion  |
| D50A | 1   | 4800-015 | Seat Cushion (units with serial number before 8650NVXXXX13) |
| D50B | 1   | 4800-074 | Seat Cushion (units with serial number after 8650NVXXXX13)  |
| D51  | 1   | 3900-391 | Cybox Decal 11.37 Vert. Wht/Wht                             |
| D52  | 1   | 4800-381 | Warning Decal   |
| D53A | 1   | 8640-598 | Placard (units with serial number before 8650NVXXXX13)      |
| D53B | 1   | 8640-597 | Placard (units with serial number after 8650NVXXXX13)       |
| D54  | 1   | HN704000 | Hex Nut .375-16   |
| D55  | 1   | HN704400 | Jam Nut .375-16   |
| D56  | 1   | HP286819 | Spiral Pin  |
| D57  | 1   | 8640-330 | Spring Pin 10 mm x 90 mm Black                              |
| D58  | 1   | 02120    | Pulley Mount  |
| D59  | 1   | 08229    | Detent Pin  |
| D60  | 1   | 8640-211 | Cushion Bracket   |
| D61  | 1   | 8640-212 | Cushion Post  |
| D62  | 1   | 8640-214 | Leg Bar   |
| D63  | 1   | 8640-334 | Support Plate   |
| D64  | 2   | FB130206 | Flange Bearing 2.00 x 2.25 x 1.00                           |
| D65  | 2   | HS347700 | Washer  |
| D66  | 2   | PP080224 | Plastic Insert 2.00 Dia.                                    |
| D67  | 1   | PP090000 | Plastic Insert 1.50 x 2.00 Dia.                             |
| D68  | 2   | 08017    | Retaining Ring .375   |
| D69  | 6   | JS347400 | Interanl Tooth Lockwasher                                   |

# 8640 - Leg Extension/Leg Curl Station

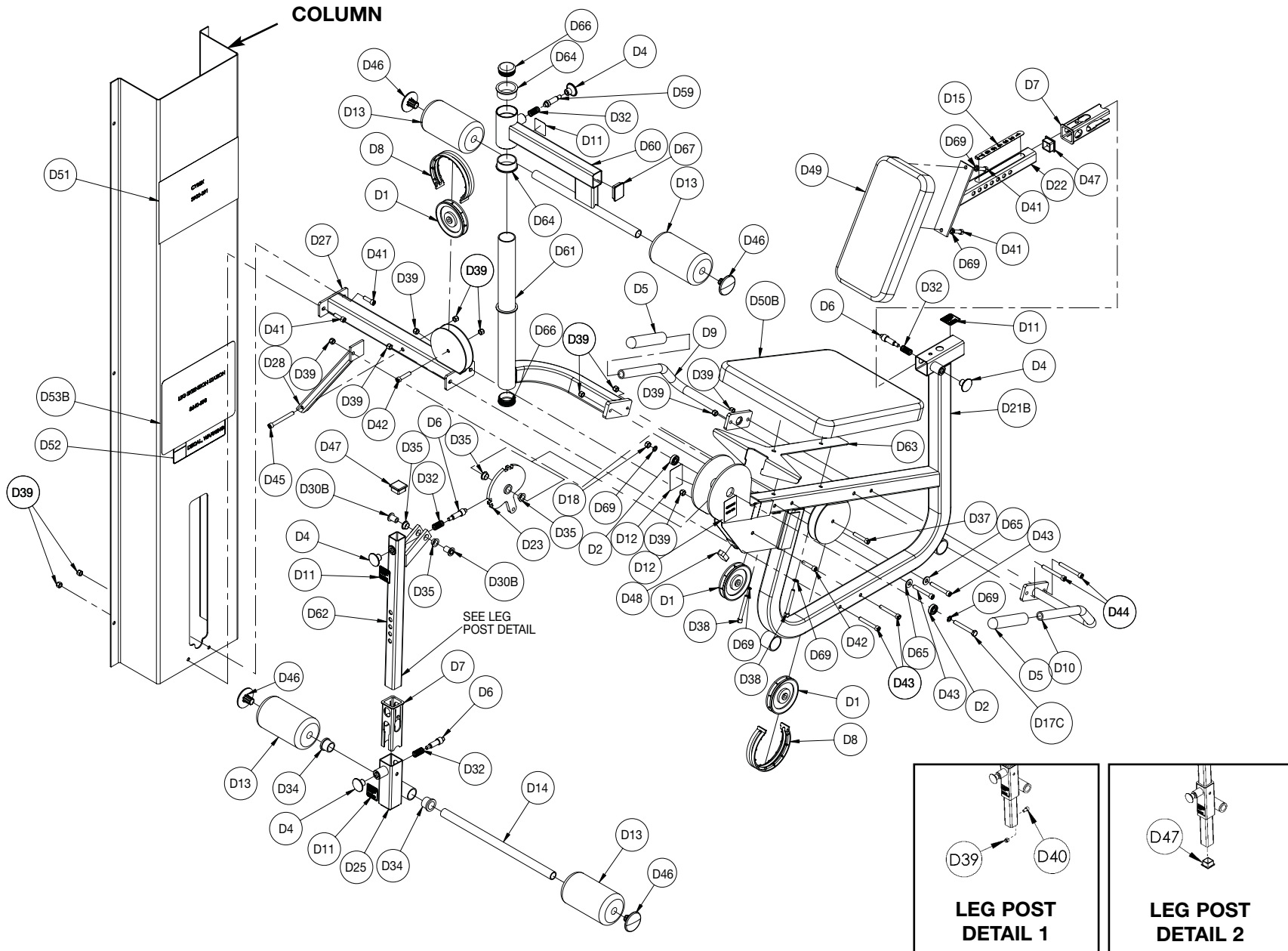

**8650 - Main Frame**

| ITEM | QTY | PART NO. | DESCRIPTION                             |
|------|-----|----------|---|
| E1   | 20  | 08014    | Pulley                                  |
| E2   | 3   | 3900-391 | Cybox Decal 11.37 Vert. Wht/Wht         |
| E3   | 3   | 4700M005 | Rubber Cap                              |
| E4   | 6   | 4700-019 | Flange Bearing .62 ID x .95 OD x 1.50 L |
| E5   | 3   | 4800-256 | Top Weight                              |
| E6   | 3   | 4800-381 | Warning Decal                           |
| E7   | 3   | 51119    | Selector Pin Retainer                   |
| E8   | 6   | 8550-358 | Spacer                                  |
| E9   | 1   | 8650-200 | Leg Press Column                        |
| E10  | 1   | 8650-209 | Pressing Column                         |
| E11  | 1   | 8650-202 | Fly Column                              |
| E12  | 1   | 8650-203 | Pulley Clevis                           |
| E13  | 3   | 8650-204 | Cam Bolt                                |
| E14  | 2   | 8650-205 | Pulley Adjuster                         |
| E15  | 1   | 8650-206 | Brace                                   |
| E16  | 1   | 8650-207 | Brace                                   |
| E17  | 6   | 8650-321 | Weight Rod                              |
| E18  | 3   | 8650-333 | Support Angle                           |
| E19  | 2   | 8650-339 | C/Pulley Tab                            |
| E20  | 1   | HC702830 | SHCS .375-16 x 2.50                     |
| E21  | 1   | 8650-344 | Panel                                   |
| E22  | 1   | 8650-345 | Panel                                   |

| ITEM | QTY | PART NO. | DESCRIPTION                       |
|------|-----|----------|-----------------------------------|
| E23  | 3   | 9100-313 | Weight Plate Decal 1-25           |
| E24  | 3   | BH030201 | Pin, Q Release .375 Dia. x 4.00 L |
| E25  | 6   | BR030206 | Retaining Ring                    |
| E26  | 12  | BR030214 | Retaining Ring .625 Dia.          |
| E27  | 1   | 8610-598 | Placard                           |
| E28  | 1   | 8620-598 | Placard                           |
| E29  | 1   | 8630-598 | Placard                           |
| E30  | 6   | HC702815 | SHCS .375-16 x .750               |
| E31  | 3   | HC702817 | SHCS .375-16 x 1.00               |
| E32  | 6   | HC702828 | SHCS .375-16 x 2.25               |
| E33  | 3   | HC702834 | SHCS .375-16 x 3.00               |
| E34  | 39  | HN704901 | Nylon Locknut .375-16             |
| E35  | 3   | HP286819 | Spiral Pin .188 x 1.12            |
| E36  | 21  | HS347600 | Washer .375                       |
| E37  | 3   | HS347700 | Washer .375                       |
| E38  | 15  | JC702814 | SHCS .375-16 x .625               |
| E39  | 13  | JC702824 | SHCS .375-16 x 1.75               |
| E40  | 6   | PR060005 | Weight Bumper                     |
| E41  | 1   | 8650-208 | Pulley Bracket                    |
| E42  | 2   | HC702826 | SHCS .375-16 x 2.00               |
| E43  | 2   | JC702832 | SHCS .375-16 x 2.75               |
| E44  | 6   | 8650-378 | Cable Retainer                    |

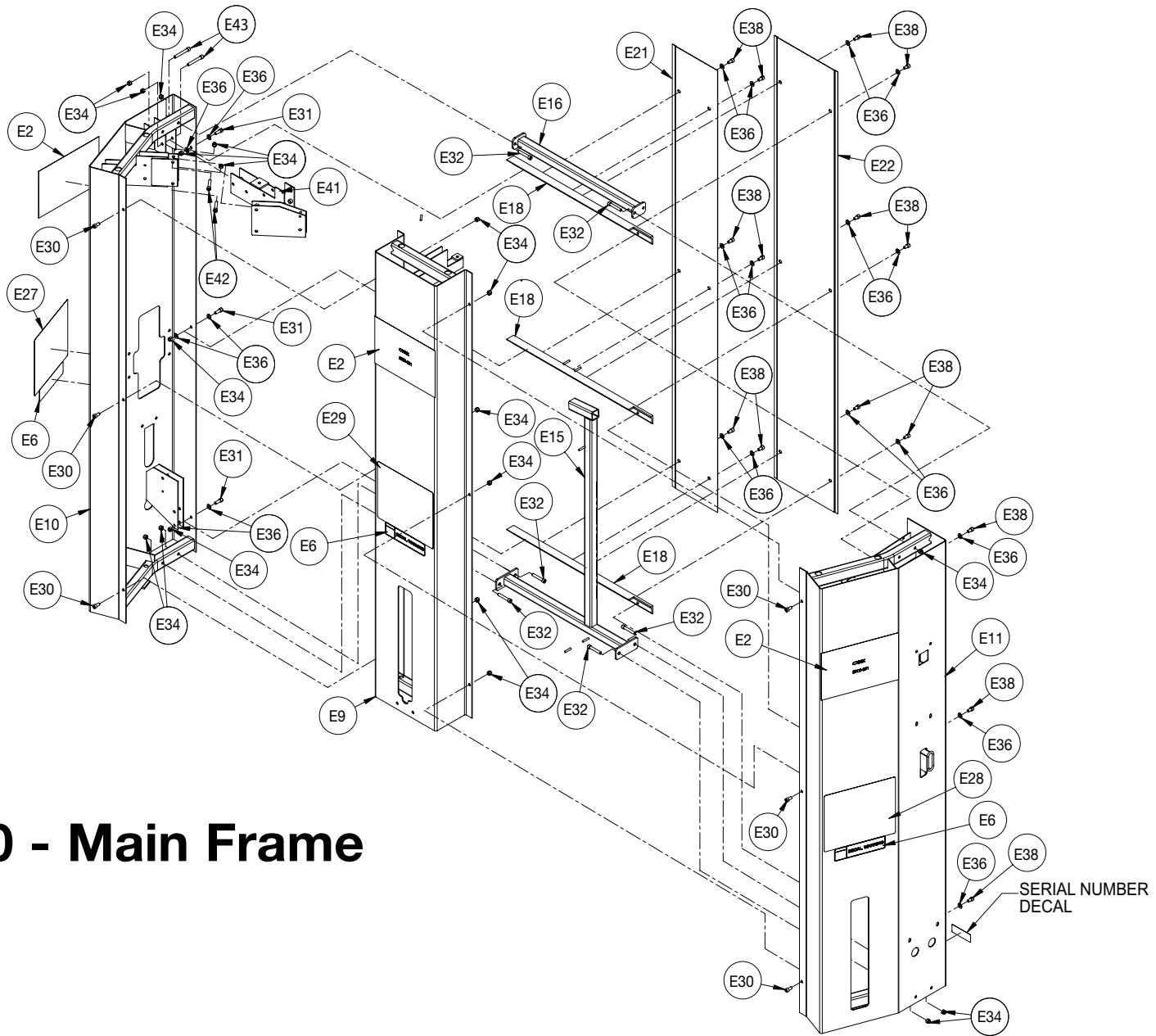

# 8650 - Main Frame

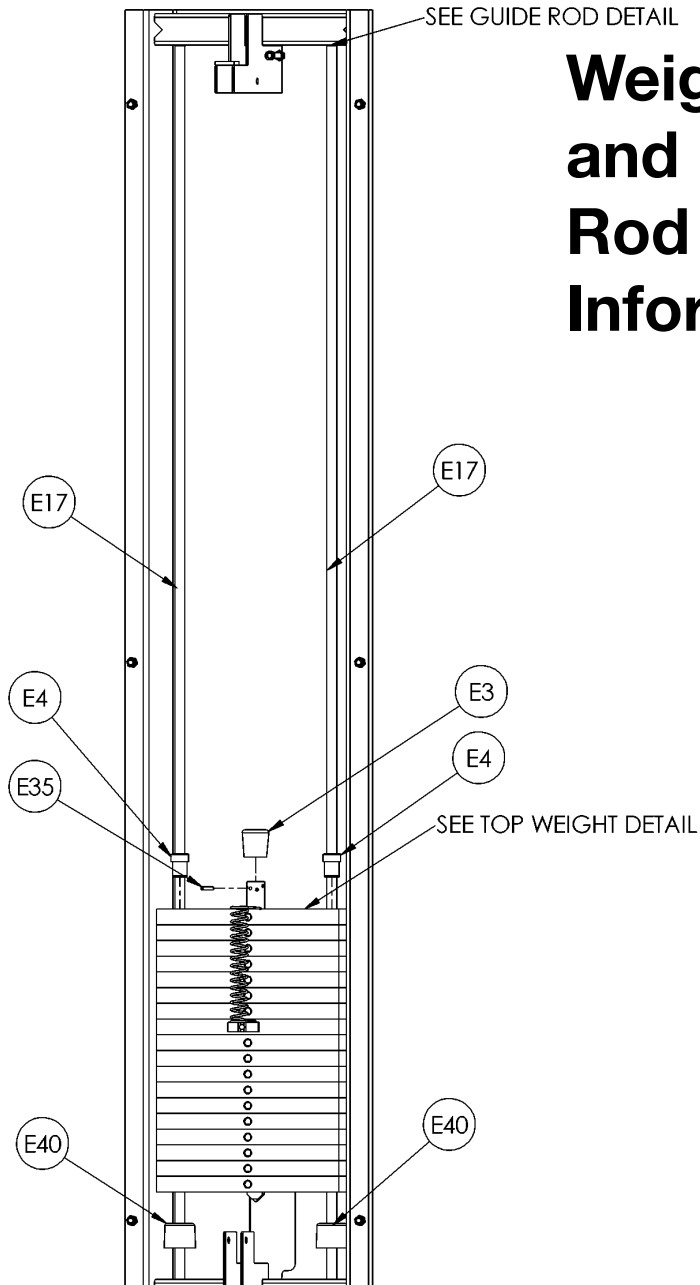

## Weight Stack and Guide Rod Information

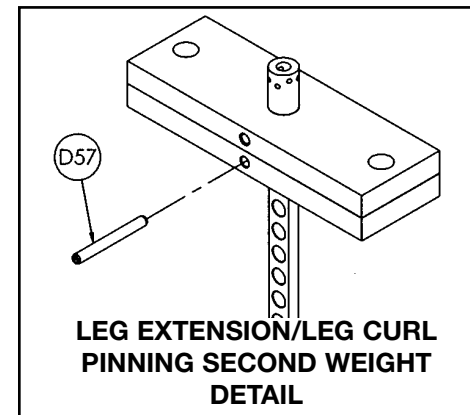
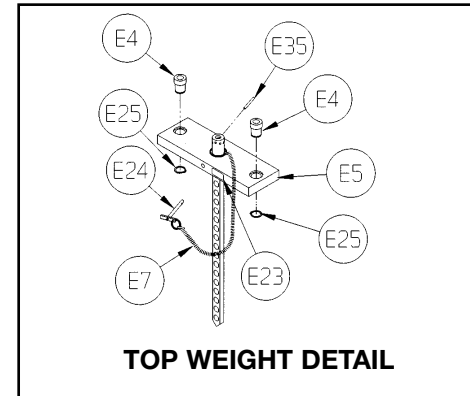
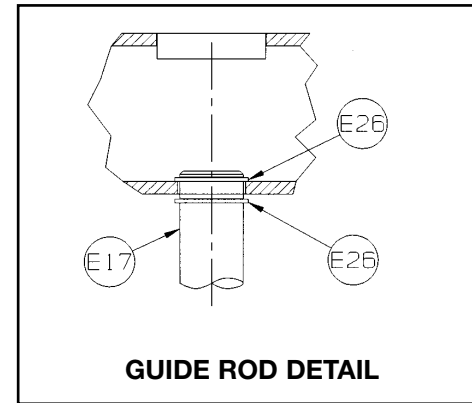

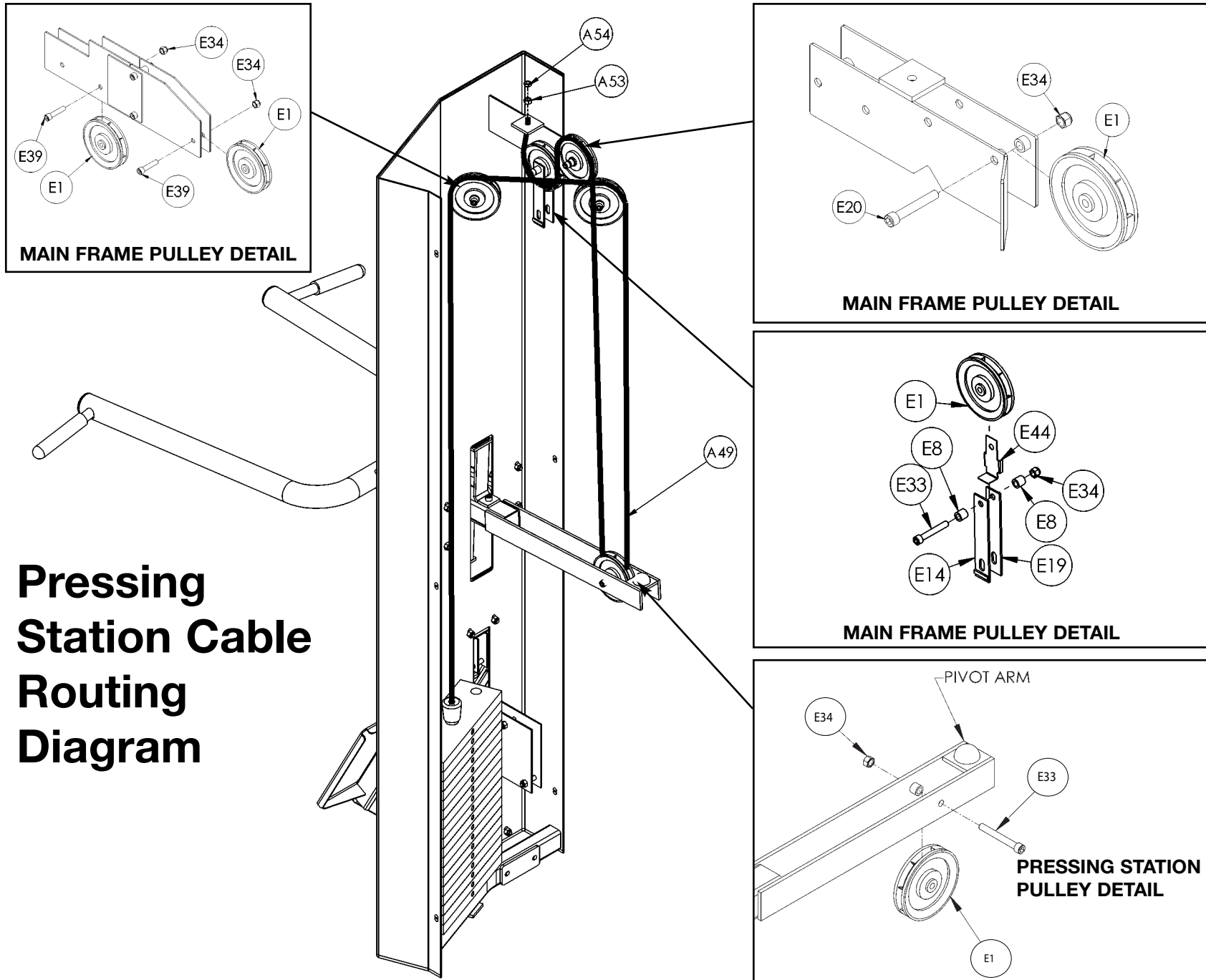

# Pressing Station Cable Routing Diagram

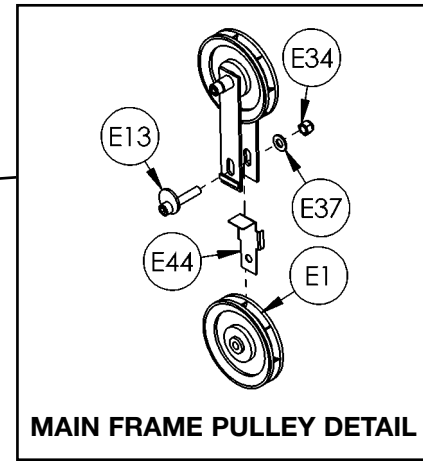
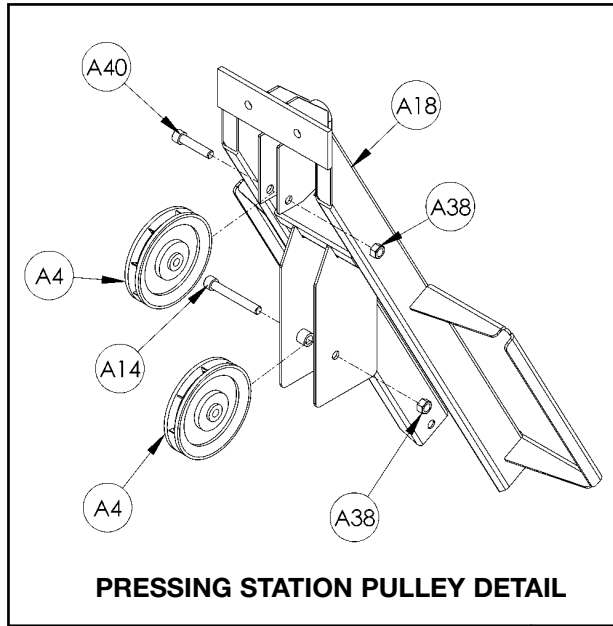

# Pressing Station Cable Routing Diagram

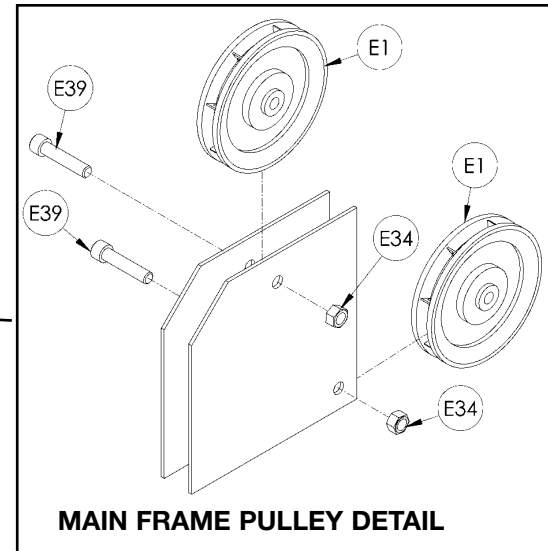
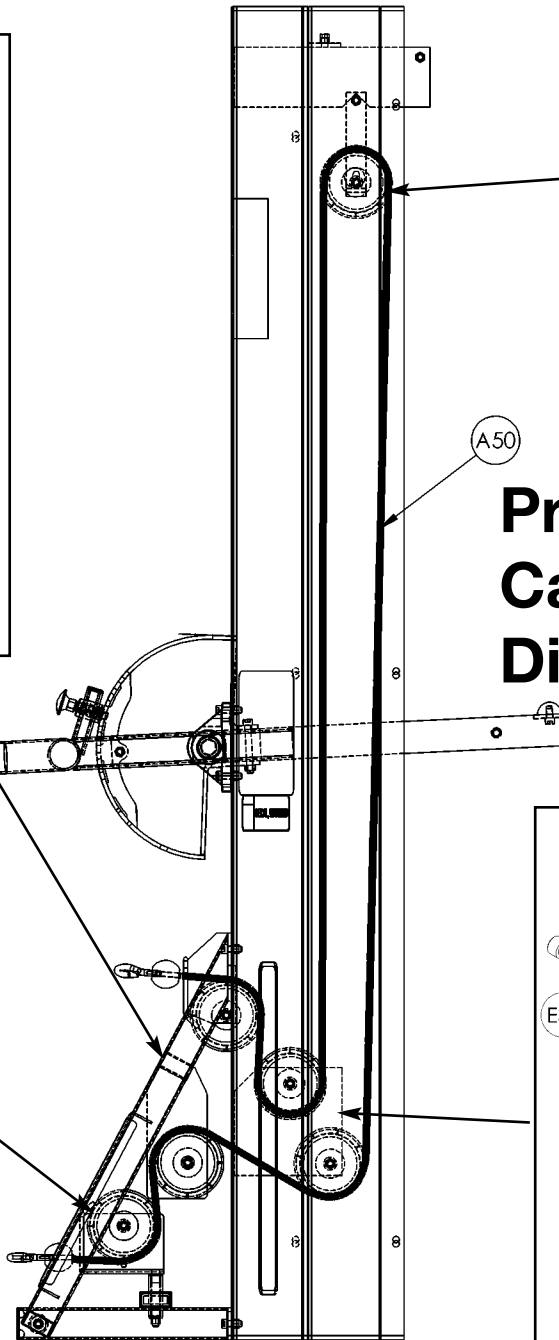
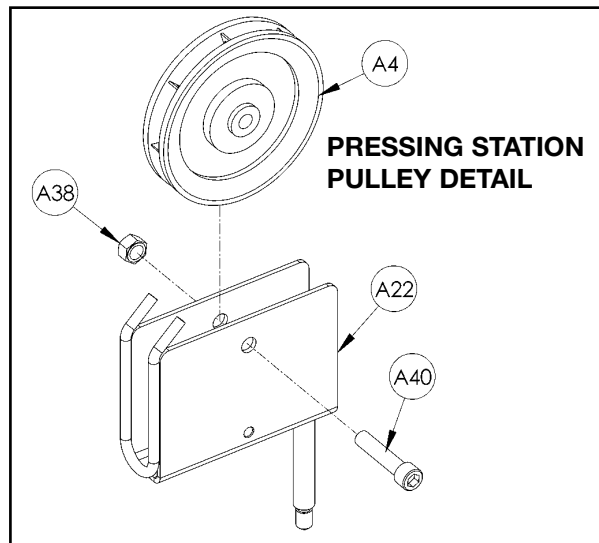

**MAIN FRAME  
PULLEY DETAIL**

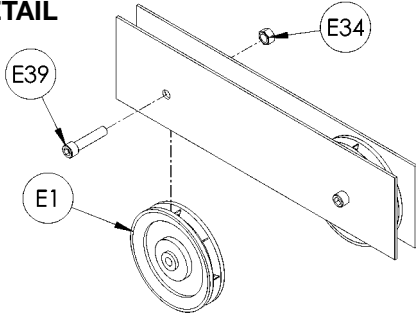

**MAIN FRAME  
PULLEY DETAIL**

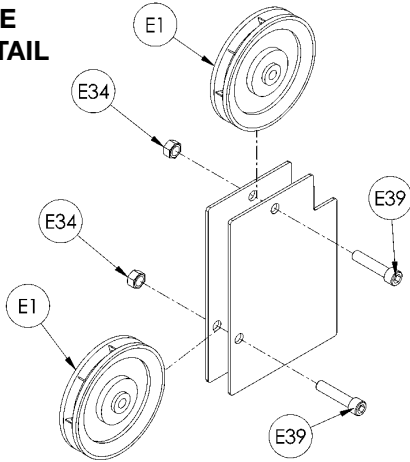

**MAIN FRAME  
PULLEY DETAIL**

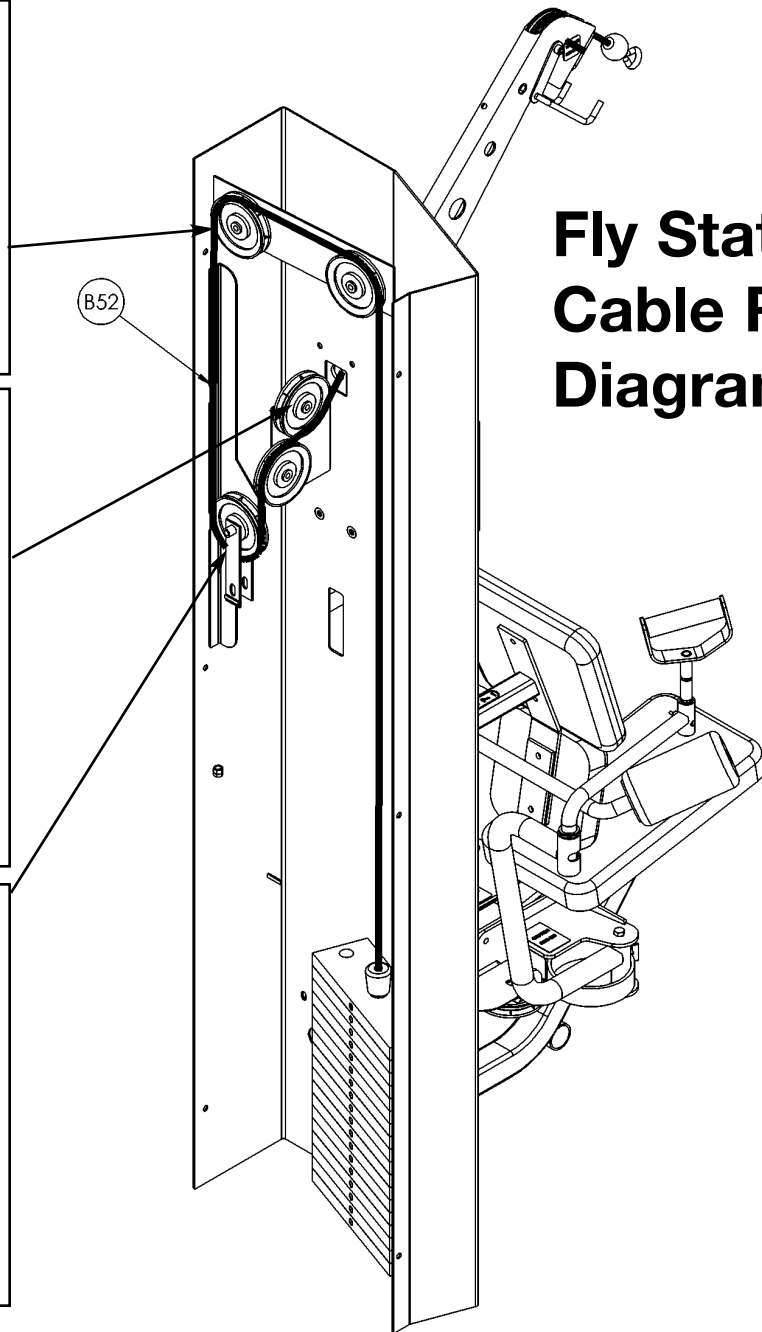
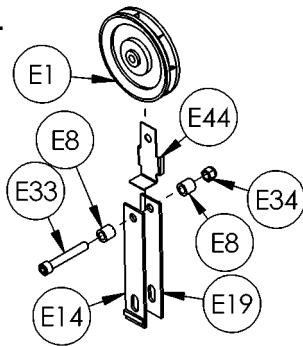

**Fly Station  
Cable Routing  
Diagram**

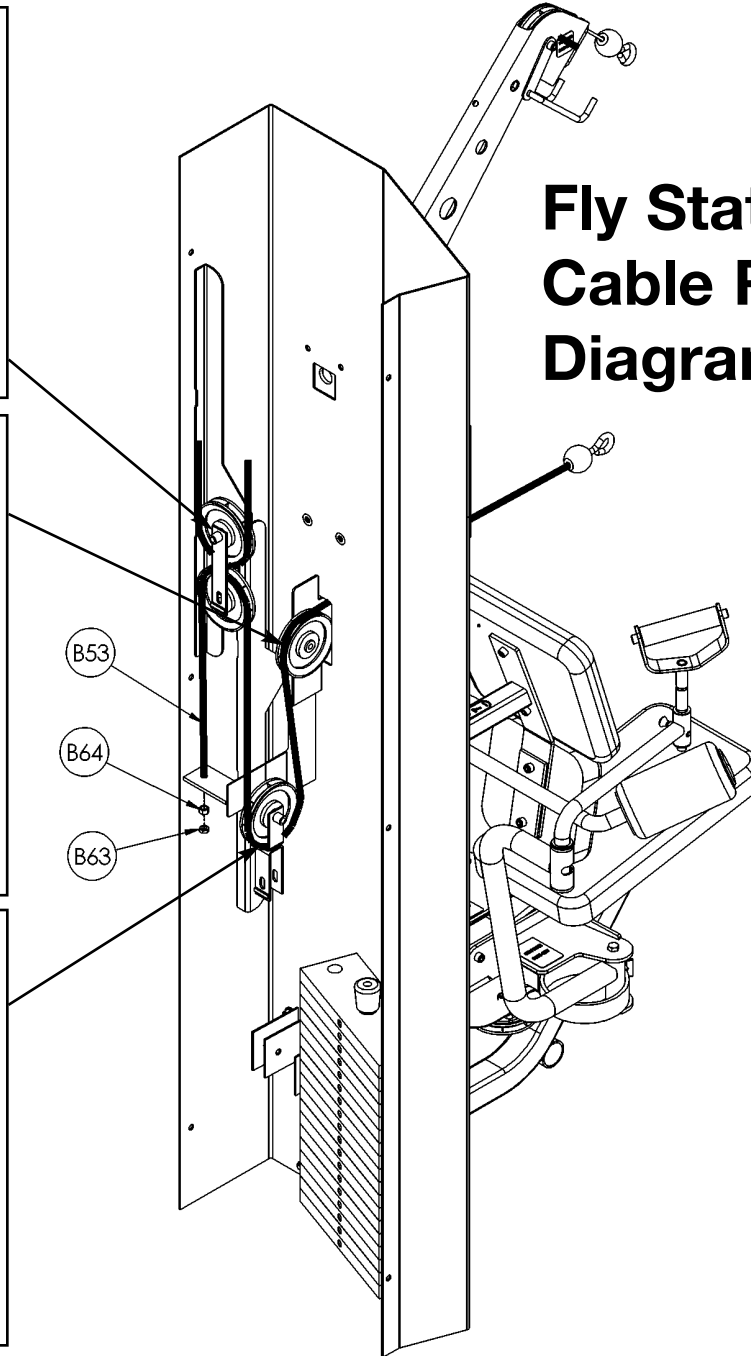
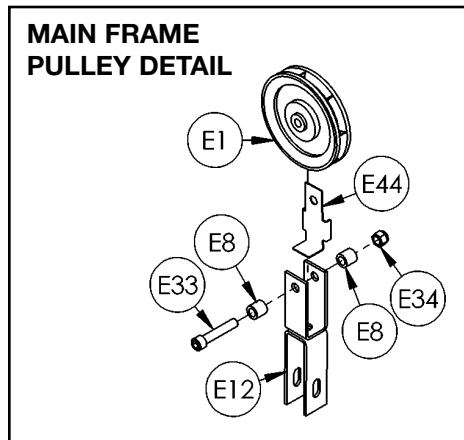
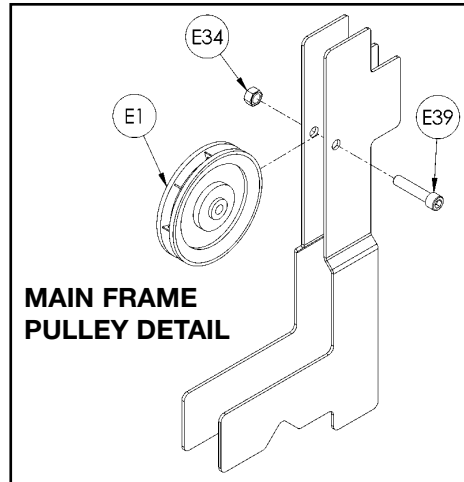
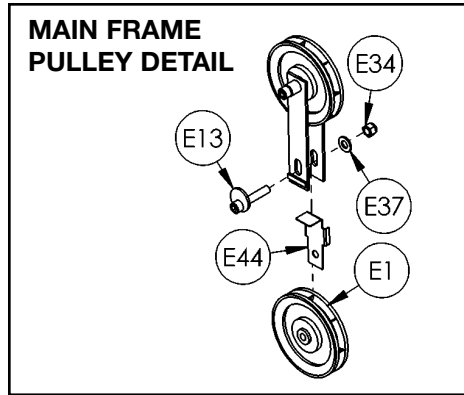

# Fly Station Cable Routing Diagram

# Fly Station Cable Routing Diagram

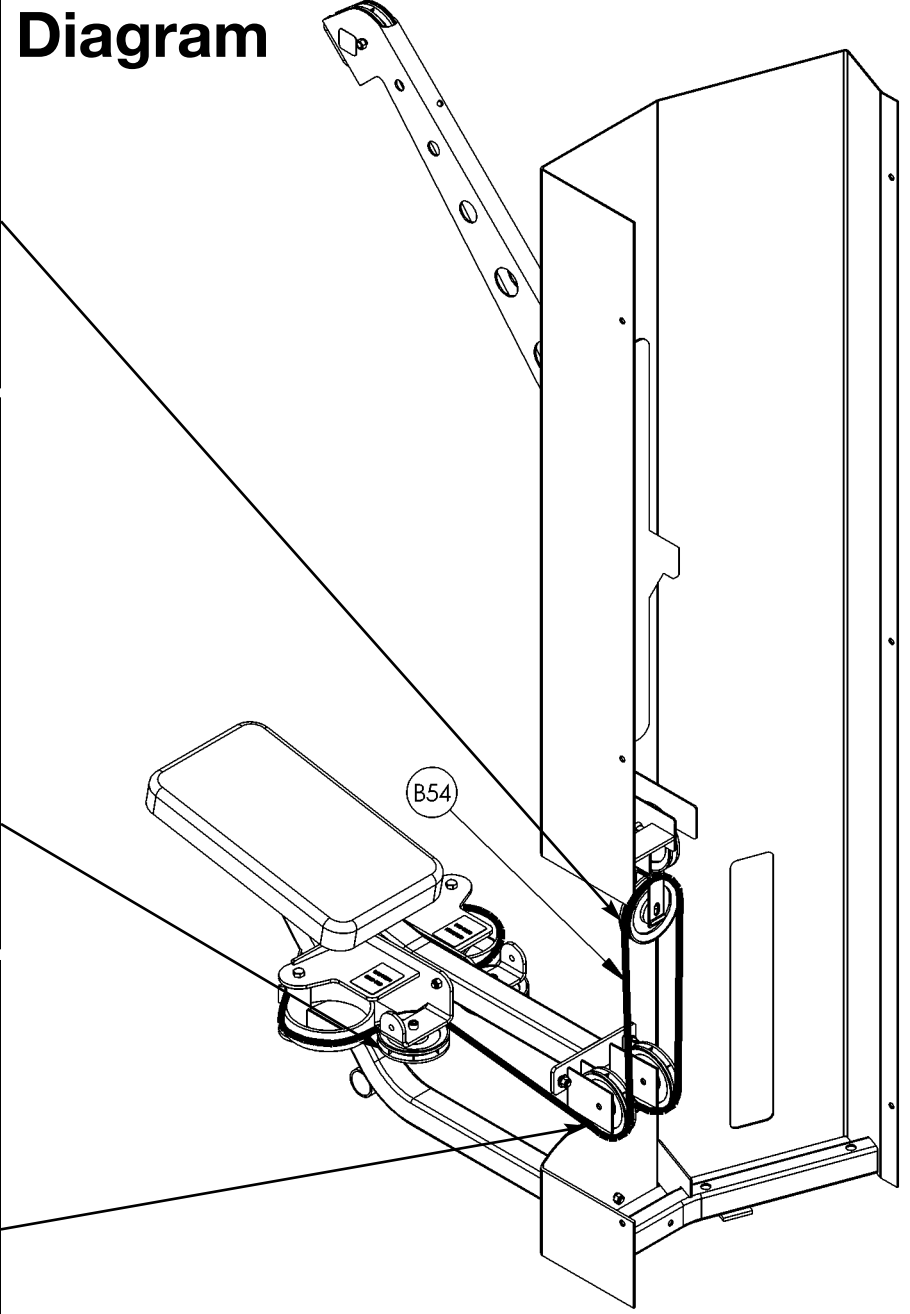
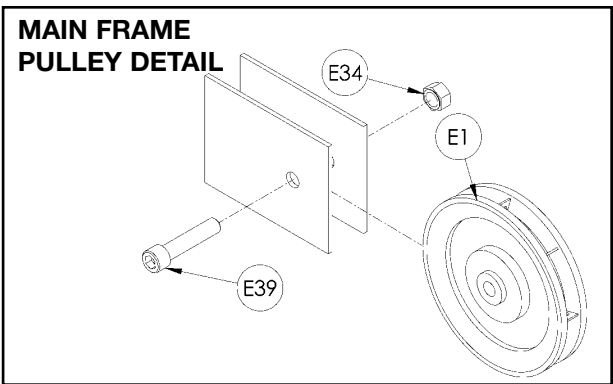
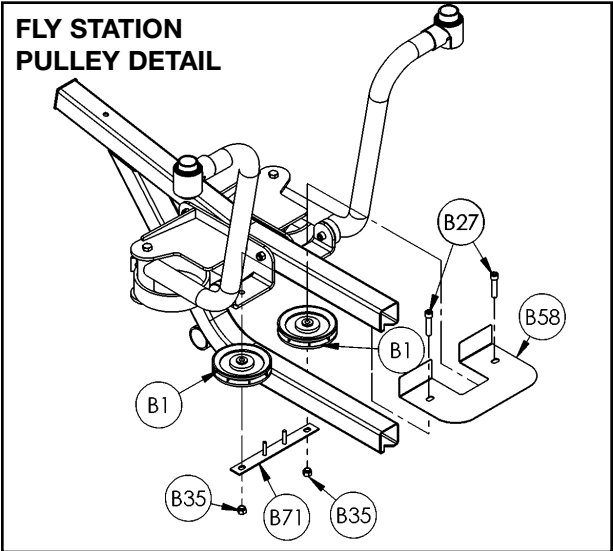
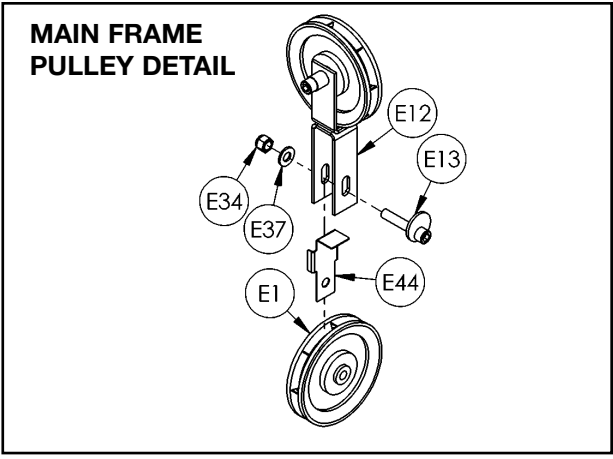

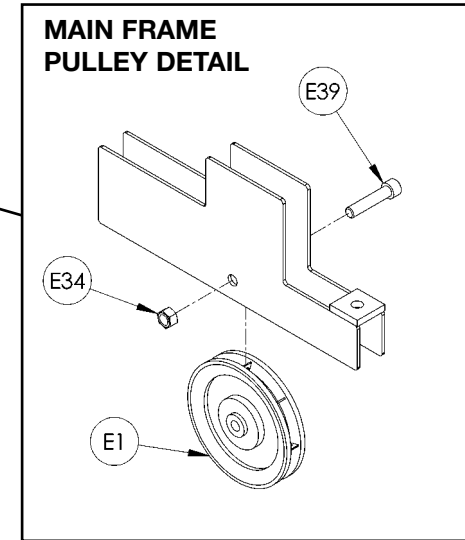
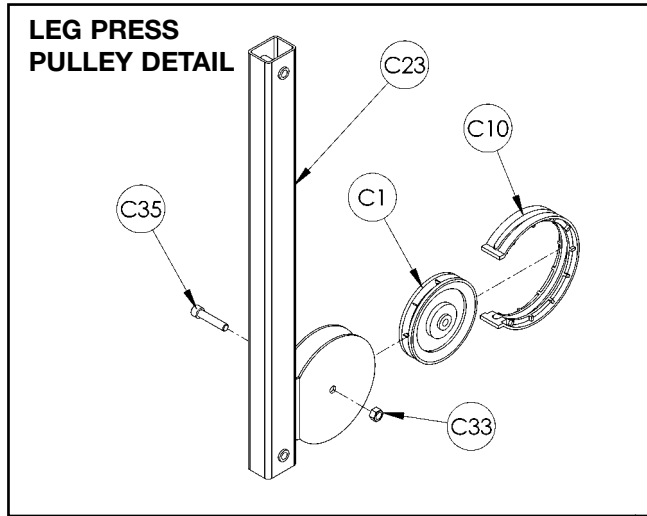

# Leg Press Station Cable Routing Diagram

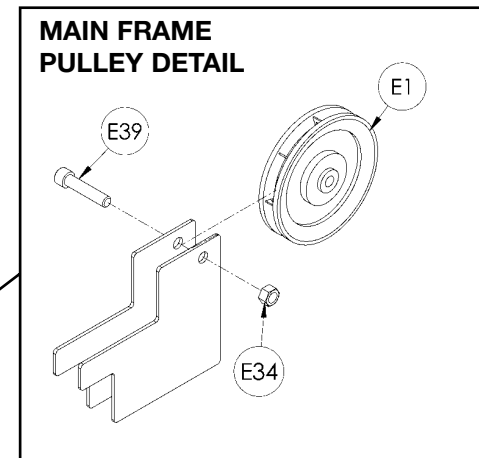
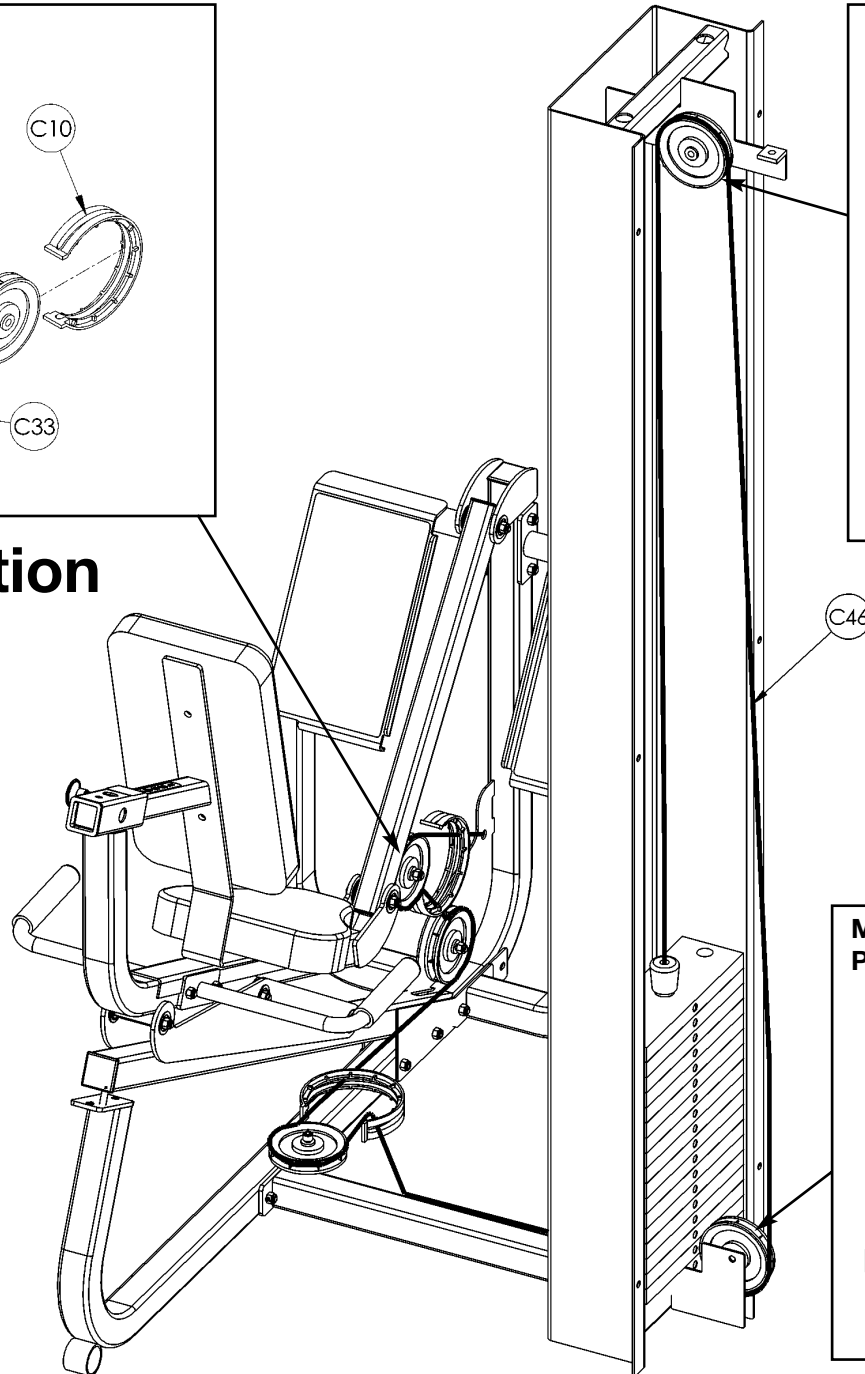

# Leg Extension/Leg Curl Station Cable Routing Diagram

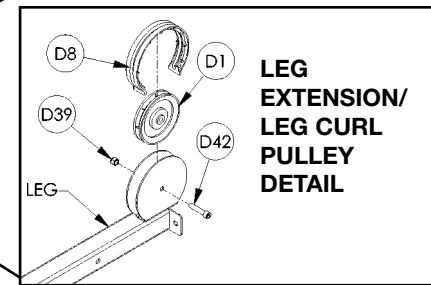
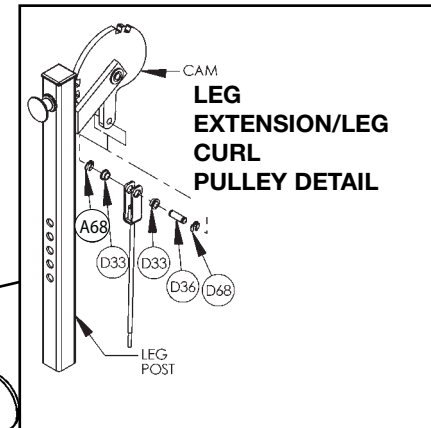
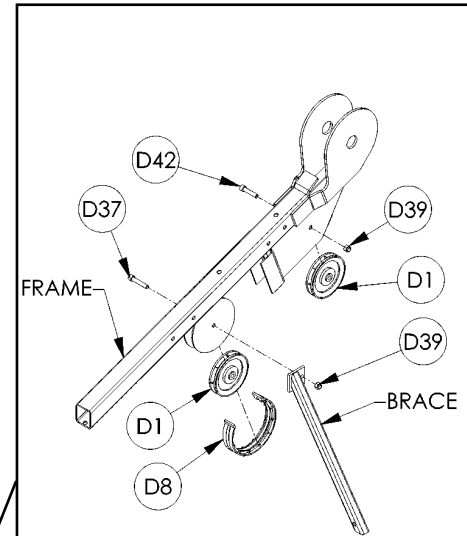
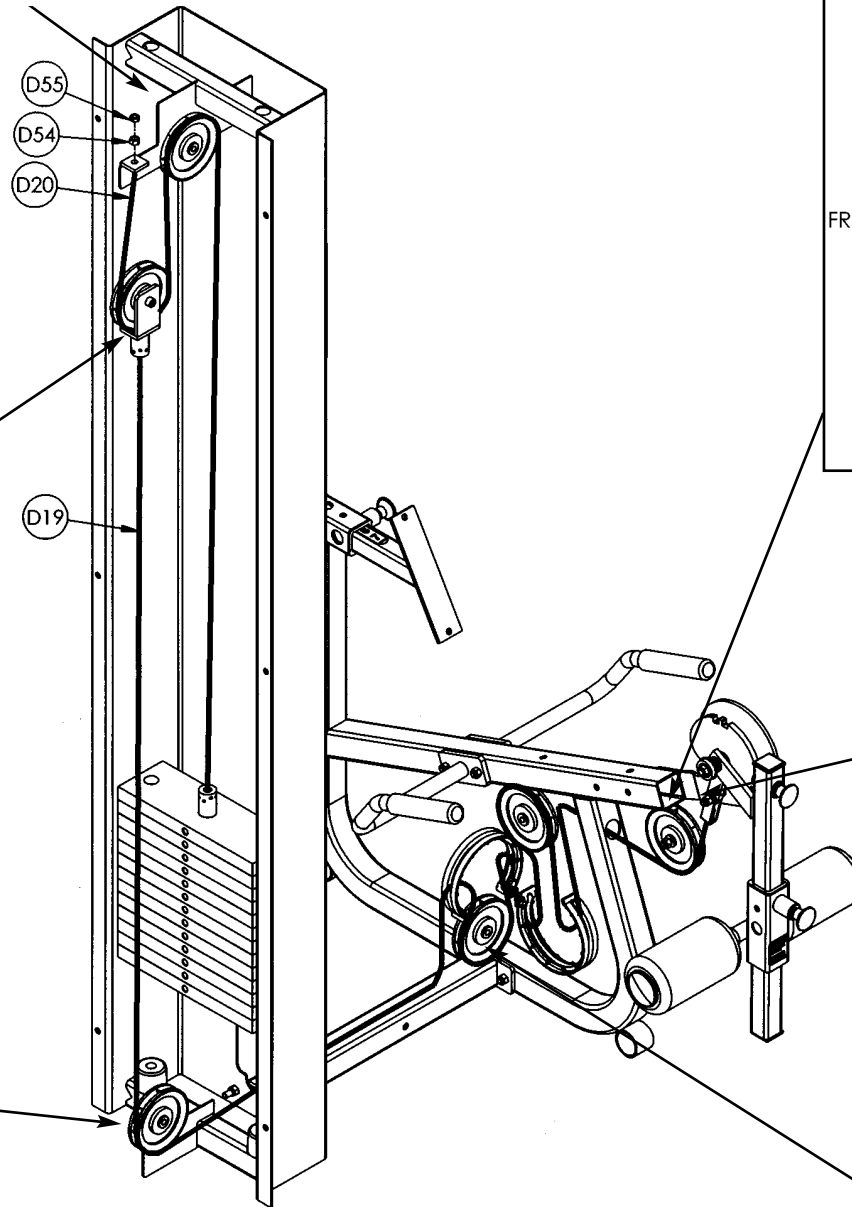
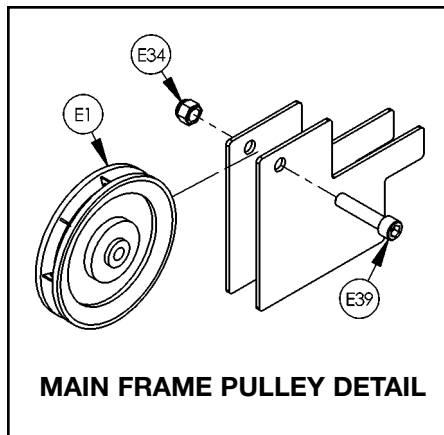
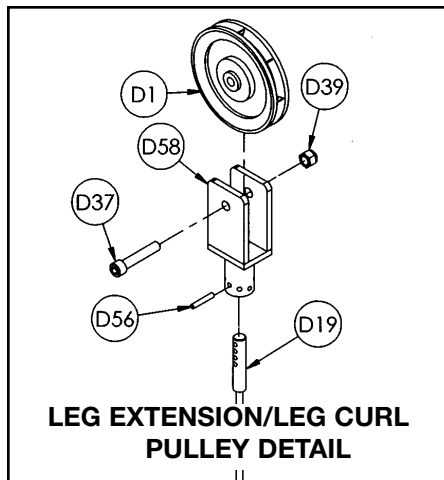
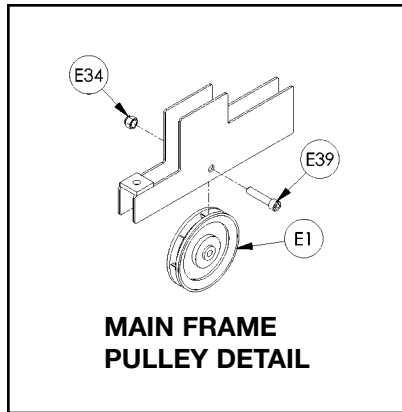







10 Trotter Drive Medway, MA 02053 • 508-533-4300 • FAX 508-533-5183  
www.cybexinternational.com • Techhelp@cybexintl.com • techpubs@cybexintl.com