



Cybex® 19040/19050 Power Rack
Owner's Manual
Strength Systems
Part Number 19040-999-4



Cybex® 19040/19050 Power Rack
Owner's Manual
Strength Systems
Part Number 19040-999-4

Cybex® and the Cybex logo are registered trademarks of Cybex International, Inc.

DISCLAIMER: Cybex International, Inc., makes no representations or warranties regarding the contents of this manual. We reserve the right to revise this document at any time or to make changes to the product described within it without notice or obligation to notify any person of such revisions or changes.

© Copyright 2010, Cybex International, Inc. All rights reserved.

Printed in the United States of America. 10 Trotter Drive Medway, MA 02053 • 508-533-4300 • FAX 508-533-5183
www.cybexintl.com • techhelp@cybexintl.com • 19040-999-4

Table of Contents

Safety

Safety	7
Safety Guidelines and Practices	8
Warning/Caution Decals	10
Regular Maintenance Activities	11

Exercise

Intended Use	13
--------------------	----

Customer Service

Contacting Service	15
Ordering Parts	15
Return Material Authorization (RMA)	16
Damaged Parts	17

Assembly

Tools Required	19
----------------------	----

Maintenance

Daily Procedures	25
Weekly Procedures	25

Safety

Safety

Read the Owner's Manual carefully before assembling, servicing or using Cybox equipment.



WARNING: Serious injury could occur if these safety precautions are not observed:

User Safety Precautions

- Obtain a medical exam before beginning any exercise program.
- Stop exercising if feeling faint, dizzy or experiencing pain and consult your physician.
- Obtain instructions before using.
- Read and understand the owner's manual and all warnings posted on the machine before using. 
- Keep all children (12 and under) away. Teenagers (13 and over) and disabled must be supervised.
- Use a spotter.
- Keep body and clothing free from and clear of all moving parts.
- Use the machine only for the intended use. **DO NOT** modify the machine.
- Inspect machine prior to use. **DO NOT** use if it appears damaged or inoperable.
- **DO NOT** attempt to fix a broken or jammed machine.
- Report any malfunctions, damage or repairs to the facility.
- Replace any warning labels if damaged, worn or illegible.

Facility Safety Precautions

- Read the Owner's Manual carefully before assembling, servicing or using this equipment.
- Make sure that each machine is set up and operated on a solid level surface. **Do not install equipment on an uneven surface.**



CAUTION: Cybox is not responsible for the actual anchoring of equipment. Consult with a professional contractor.

 **WARNING:** Use fasteners having a minimum of 500 lbs. tensile capacity (3/8" grade 2 bolts or better).

 **WARNING:** If legs/frame does not contact surface, **DO NOT** pull down with anchors. Shim any leg or frame not in contact with surface using flat washers.

- Make sure that all users are properly trained on how to use the this equipment.
- Make sure there is enough room for safe access and operation of this equipment.
- Perform regular maintenance checks on this equipment. Also pay close attention to all areas most susceptible to wear.
- Immediately replace worn or damaged components. If unable to immediately replace worn or damaged components then remove from service until the repair is made.

NOTE: It is the sole responsibility of the user/owner or facility operator to ensure that regular maintenance is performed.

Safety Guidelines and Practices

Cybex recommends that all fitness equipment be used in a supervised area. It is recommended that the equipment be located in an access controlled area. Control is the responsibility of the owner. The extent of control is at the discretion of the owner.

It is the responsibility of the purchaser/user of Cybex products to read and understand the owner's manual, and warning labels; as well as instruct all individuals, whether end users or supervising personnel, on proper usage of the equipment.

PROPER USAGE:

Use machine only as described in the manual. Failing to follow proper instructions may result in injury.

Do Not Lean Against or Pull On the framework, weight stack, or any component, whether machine is at rest or in use. Inappropriate or improper use may result in injury to users or third parties (bystanders).

Do not use machine if it is not located on a solid level surface or is improperly installed.

Provide an adequate safety perimeter between the machine, walls and other equipment to ensure that the facility has the proper clearance for usage and training.

SECURING EQUIPMENT:

The machine has holes in the feet, which allow for ease in anchoring to the floor. Cybex strongly recommends that, to eliminate rocking, tipping or falling over due to incorrect usage and misuse, equipment be secured to a solid, level surface

Cybex 19040/19050 Power Rack Owner's Manual

1. The **solid**, level surface should not deviate more than 1/8" over a 10' distance or as defined and required by local building and architectural codes.
2. Anchoring **of** equipment must be completed by a qualified licensed contractor.
3. Anchoring **holes** are provided on the feet of the frame. All anchoring locations must be used when used when anchoring the equipment to the floor.
4. Due **to** the wide variation of flooring on which machines may be anchored or installed, verify anchoring method and anchoring fasteners with a qualified and licensed contractor.
5. A **minimum** pull out force of 220 lbs/100 kgs is required for each anchor position.
6. Do **not** use machine until it is properly anchored.

MAINTENANCE:

Preventative maintenance allows proper equipment operation and reduces the risk of injury. Perform the maintenance requirements as specified in the manual.

STANDARD COMPLIANCE:

Cybex products meet or exceed applicable ASTM and EN Standards.

Warning/Caution Decals

Warning decals indicate a potentially hazardous situation, which, if not avoided, could result in death or serious injury.

Caution decals indicate a potentially hazardous situation, which, if not avoided, could result in minor or moderate injury.

The following diagram shows where each decal is located.

⚠ WARNING

**SERIOUS INJURY
COULD OCCUR IF
THESE PRECAUTIONS
ARE NOT OBSERVED**

1. Obtain a medical exam before beginning any exercise program.
2. Stop exercising if feeling faint, dizzy or experiencing pain and consult your physician.
3. Obtain instructions before using. *Lisez les instructions avant l'utilisation.*
4. Read and understand the owner's manual and all warnings posted on the machine before using. [A]
5. Keep all children (12 and under) away. Teenagers (13 and over) and disabled must be supervised. *Garder tous les enfants (de 12 ans et moins) éloignés. Les adolescents (de 13 ans et plus) et les handicapés doivent être surveillés.*
6. Use a spotter.
7. Keep body and clothing free from and clear of all moving parts.
8. Use the machine only for the intended use. **DO NOT** modify the machine.
9. Inspect machine prior to use. **DO NOT** use if it appears damaged or inoperable.
10. **DO NOT** attempt to fix a broken or jammed machine.
11. Report any malfunctions, damage or repairs to the facility.
12. Replace any warning labels if damaged, worn or illegible.

5220-364-4 A

19040/19050 Power Rack

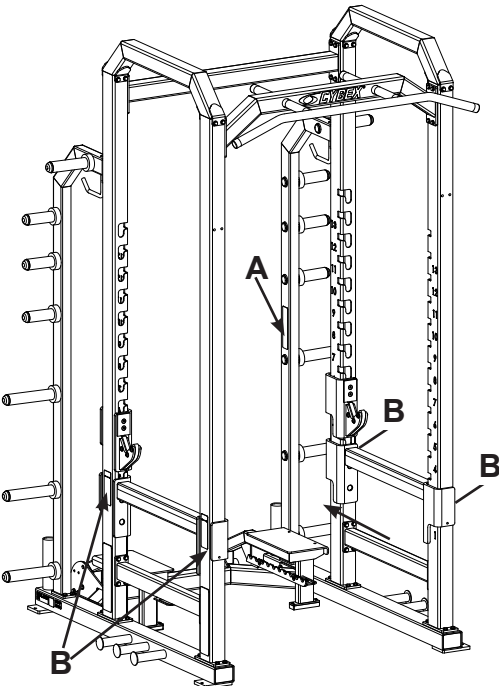

Description **Part No.**

A. Warning Decal.....5220-364-4

B. Warning Decal.....16240-329-4

⚠ WARNING

↔

Serious injury or death may result if the adjustable bar stops are set BELOW THIS location when doing SQUAT EXERCISE.

DO NOT start SQUAT EXERCISE unless adjustable bar stops are in place.

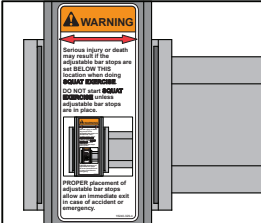

PROPER placement of adjustable bar stops allow an immediate exit in case of accident or emergency.

16240-329-4

Regular Maintenance Activities

Preventative maintenance activities must be performed to maintain normal operation of this equipment. Keeping a log sheet of all maintenance actions will assist you in staying current with all preventative maintenance activities.



WARNING: *Equipment found to have worn or damaged components must be removed from service until repair(s) is made. Failure to do so could result in injury.*

Daily

1. Clean **upholstery**.

Weekly

1. Inspect **all** nuts and bolts for looseness. Tighten as required.
2. Check **for** worn handles and worn labeling. Replace all worn parts immediately.

Exercise

Intended Use

The intended use of this equipment is to aid or improve general physical fitness and exercise. For Commercial use.

Before you workout

Prior to starting a training program, get a complete physical exam to make sure your physician agrees that you are ready. Always warm-up your muscles before a workout. A 5 - 10 minute cardio warm-up followed by slow stretching (no bouncing) is recommended. Continue with a lighter set (50% of normal) of intended exercises. Start your program conservatively. Choose weights you can easily lift in the first weeks. Always perform the full range of motion unless you have an injury, then consult a professional trainer. Know the terms A "repetition" (rep) is defined as one complete movement through an exercise, returning to the start position. A "set" is a continuous series of reps usually between 6-15.

During your workout

The number of reps you perform in a set depends on your goal. To build muscle and strength, do fewer reps (6 - 8) with heavier weight. To build endurance, do more reps (12-15) with lighter weight. Never "cheat" by shortening the range of motion, bouncing the weight, or shifting your posture. This may allow you to lift more weight, but it is dangerous and less effective. Catch your breath between sets, then continue. When "circuit training" move briskly to the next exercise; when doing multiple sets on one exercise, rest 45 - 90 seconds before the next set. Work up to three sets per exercise. When you can perform the desired reps and sets for any exercise, increase the weight by a half or full plate.

Designing your workout

Circuit training is a good way to start. This involves doing one set per exercise, then moving to the next exercise, pausing only briefly between them (to keep your heart and breath rate up) until completing a balanced "circuit" of 8 - 10 exercises for your entire body. Then repeat the circuit. After several weeks, you can move into multiple sets (3 in a row) per exercise if you choose. For both of these, exercise the complete body every other day, up to three times a week. **NOTE:** *A full day's rest, plus proper nutrition and hydration are required for optimum muscle-building or toning.* Alternatively, work out half your body one day (e.g., the upper body) and the other half the following day (e.g. the lower body). At the end of your workout, cool down in a similar way to your warm-up.

Customer Service

Contacting Service

Hours of phone service are Monday through Friday from 8:30 a.m. to 6:00 p.m Eastern Standard Time.

For Cybox customers living in the USA, contact Cybox Customer Service at **888-462-9239**.

For Cybox customers living outside the USA, contact Cybox Customer Service at **508-533-4300** or fax **508-533-5183**.

Find information on the web at www.cyboxintl.com or e-mail at techhelp@cyboxintl.com.

Ordering Parts

Fax orders to **508-533-5183**. To speak with a customer service representative, call **888-462-9239** (for customers living within the USA) or **508-533-4300** (for customers outside the USA). You may also contact us through e-mail at techhelp@cyboxintl.com.

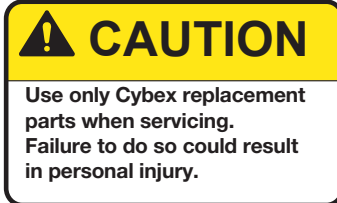

***NOTE:** All inspections and repairs must be performed by trained service personnel only.*

Cybox will void warranty if non-Cybox replacement parts are used.

Having the following information ready when calling, will assist our Cybox representatives in serving you.

- **Unit Serial Number**
- **Product Name**

The unit serial number and product name can be found on the serial number decal.

- **Part Description**
- **Part Number**

Part descriptions and part numbers are located on the web at www.cyboxintl.com.

- **Shipping Address**
- **Contact Name**

In addition to your shipping address and contact name, your account number is helpful but not required.

Return Material Authorization (RMA)

The Return Material Authorization (RMA) system outlines the procedures to follow when returning material for placement, repair or credit. The system assures that returned materials are properly handled and analyzed. Follow the following procedures carefully.

Contact your authorized Cybox dealer on all warranty-related matters. Your local Cybox dealer will request a RMA from Cybox, if applicable. Under no circumstances will defective parts or equipment be accepted by Cybox without proper RMA and an Automated Return Service (ARS) label.

1. Call the Customer Service Hot Line listed above for the return of any item that is defective.
2. Provide the technician with a detailed description of the problem you are having or the defect in the item you wish to return.
3. Provide the model and serial number of your Cybox equipment.
4. At Cybox's discretion, the technician may request that you return the problem part(s) to Cybox for evaluation and repair or replacement. The technician will assign you a RMA number and will send you an ARS label. The ARS label and the RMA numbers must be clearly displayed on the outside of the package that contains the item(s) to be returned. Include the description of the problem, the serial number of the equipment and the name and address of the owner in the package along with the part(s).
5. Forward the package through UPS to Cybox.

Attn: Customer Service Department
Cybox International, Inc.
1975 24th Ave SW
Owatonna, MN 55060

NOTE: *Merchandise returned without an RMA number on the outside of the package or shipments sent COD will not be accepted by the Cybox receiving department.*

Damaged Parts

Materials damaged in shipment should not be returned for credit. Shipping damages are the responsibility of the carrier (UPS, Federal Express, trucking companies, etc.)

Apparent Damage - Upon receipt of your shipment, check all items carefully. Any damage seen with a visual check must be noted on the freight bill and signed by the carrier's agent. Failure to do so will result in the carriers refusal to honor your damage claim. The carrier will provide you with the required forms for filing such claims.

Concealed Damage - Damage not seen with a visual check upon receipt of a shipment but notices later must be reported to the carrier as soon as possible. Upon discovery of the damage, a written or phone request to the carrier asking them to perform an inspection of the materials must be made within ten days of the delivery date. Keep all shipping containers and packing materials as they will be needed in the inspection process. The carrier will provide you with an inspection report and the necessary forms for filing a concealed damage claim. Concealed damage claim is the carrier's responsibility.

Assembly

Tools Required

- 9/16" Torque wrench
- 7/16" Wrench
- 9/16" Wrench (2)
- 6' Step Ladder (minimum)

19040/19050 Power Rack

Total Weight and Size

W x L - 70" (177 cm) W x 74" (188 cm) L

Height - 19040 - 109" (277 cm); 19050 - 97.5" (248 cm)

Weight - 19040 - 900 lbs (409 kg); 19050 - 895 lbs (407 kg)

NOTE: Three people will be required for this procedure.

NOTE: It is the responsibility of the facility owner/owner of the equipment to ensure that there is appropriate clearance around each machine to allow for safe use and passage.

1. Read and understand all instructions thoroughly before starting any of the procedures listed below. 
2. Verify you have received the appropriate configuration.
 - Verify you received the correct color machine that you ordered.
 - Verify you received the appropriate owner's manual.
 - Verify you received the warranty sheet.

⚠ WARNING: Use extreme caution when removing from pallet. Failure to do so could result in injury.

3. Move to desired location and unpack. Remove items from pallet in the order shown on the following diagram. Carefully handle parts to prevent damage to paint or frame.

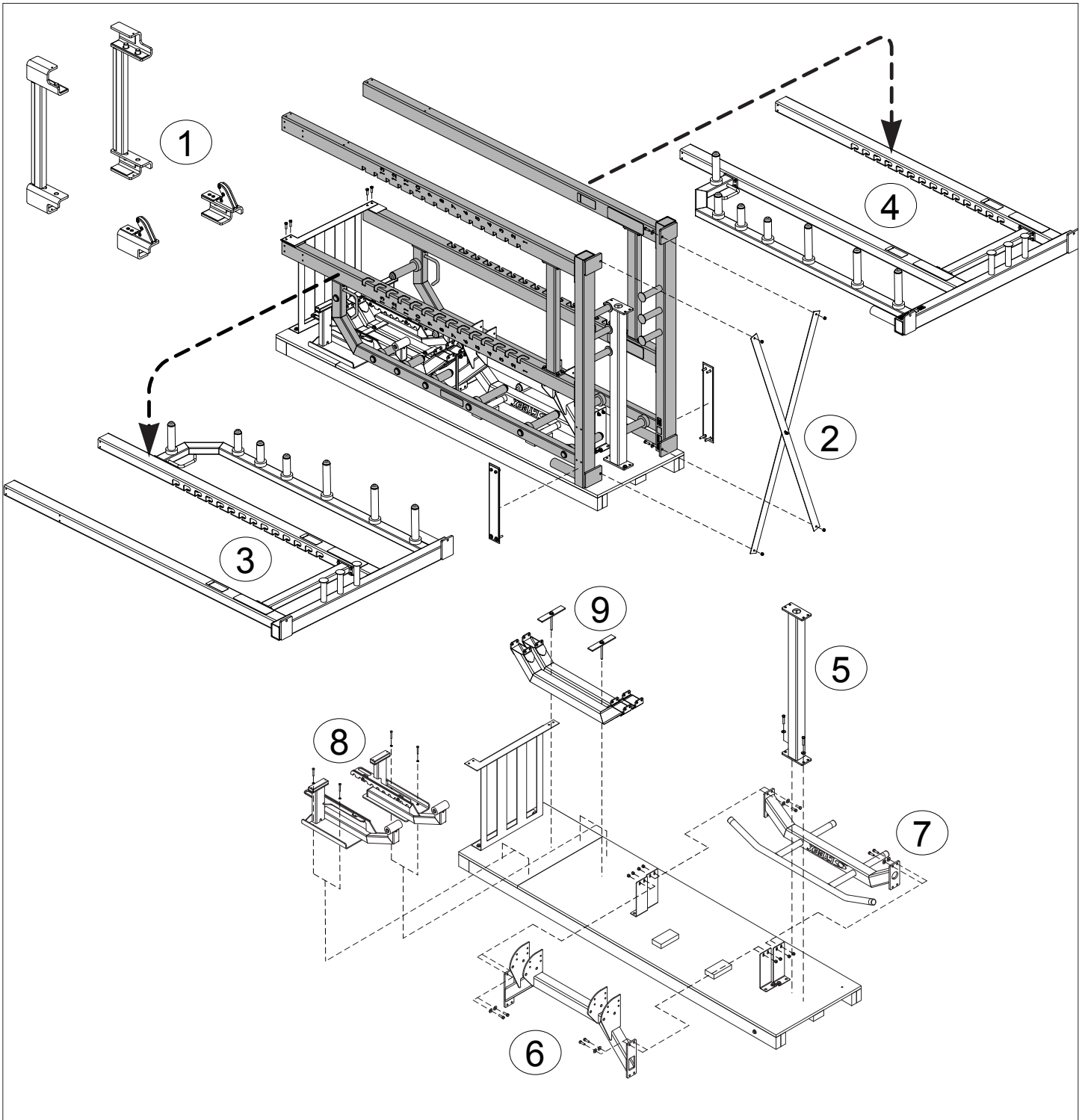

4. Assemble Rack in area it will be used..

Attach Upper Side to both sides. Attach bottom cross to both sides.

Using a step ladder, carefully attach Upper Cross to both sides. Carefully attach Upper Handle Bar to both sides.

- A. Pivot Shaft (2), 19000-346
- B. HX HD Flg Serated Cap Screw .375-16 X .75 (52), JC701115
- C. Black Insert (4), PP080221
- D. Adjustable Bar Stop (2), 19020-100
- E. Nylon Locknut .375-16 (8), HN704901
- F. Mounting Plate (2), 19000-345
- G. Mounting Plate Screws (4), JC620415
- H. Bumper (2), 11000-384
- I. Bar Catch RH (1), 19220-100
- J. Bar Catch LH (1), 19220-101

Securely tighten all screws to 450 - 500 inch/pounds.

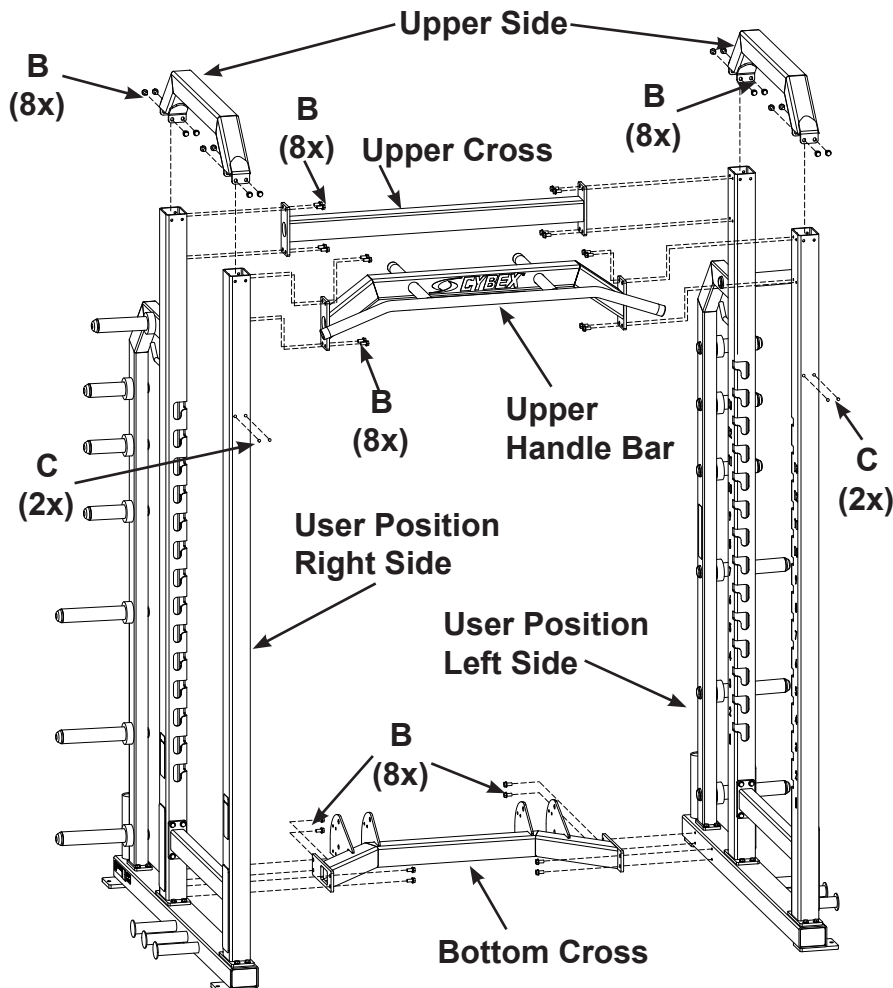

5. Attach Spotter Stands to Bottom Cross. Securely tighten all screws to 450 - 500 inch/pounds.

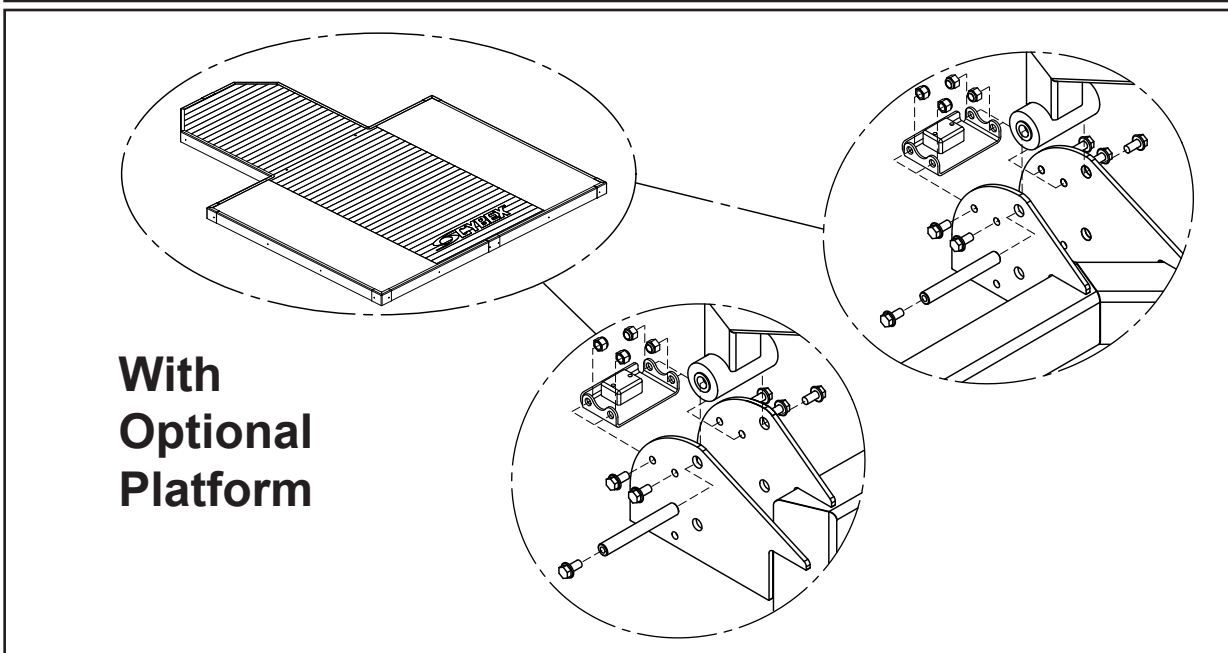
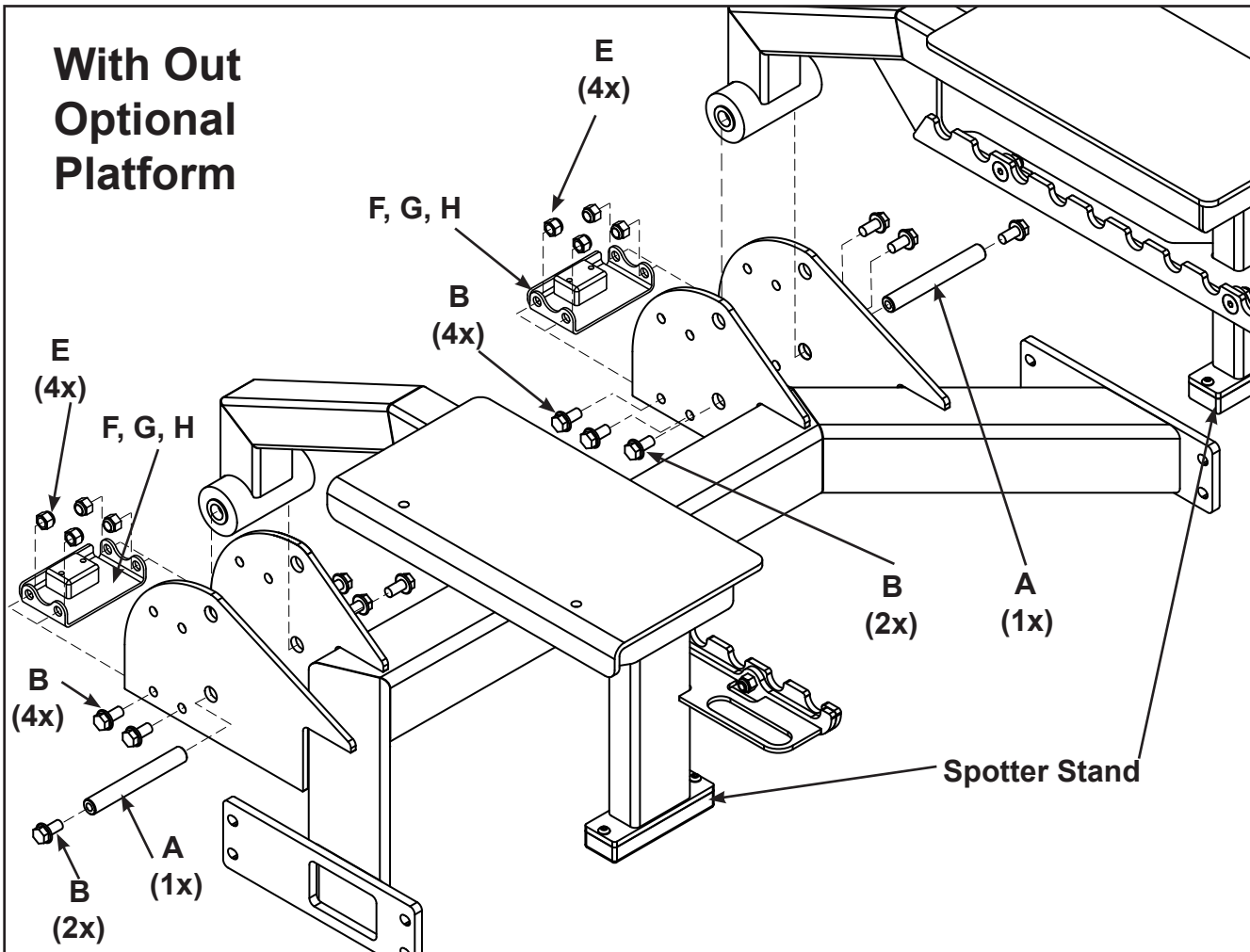

6. Attach Adjustable Bar Stops (D) to desired position. Attach each Bar Catch (I and J) to desired position.

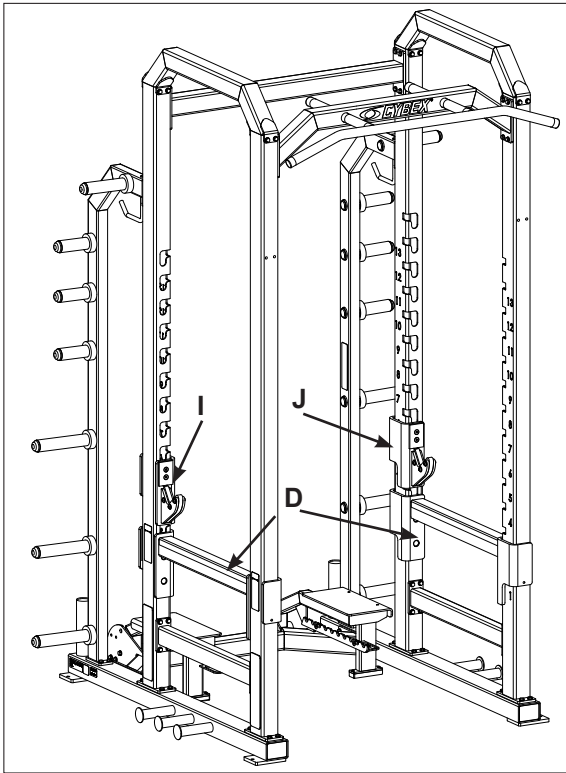

7. Securely anchor machine to the floor using the anchor holes provided in each machine.

- ⚠ CAUTION:** *Cybox is not responsible for the actual anchoring of equipment. Consult with a professional contractor.*
- ⚠ WARNING:** *Use fasteners having a minimum of 500 lbs. tensile capacity (3/8" grade 2 bolts or better).*
- ⚠ WARNING:** *If legs/frame does not contact surface, DO NOT pull down with anchors. Shim any leg or frame not in contact with surface using flat washers.*

8. Verify proper operation.

Maintenance

All preventive maintenance activities must be performed on a regular basis. Performing routine preventive maintenance actions can aid in providing safe, trouble-free operation of all Cybox Strength Systems equipment.

NOTE: *Cybox is not responsible for performing regular inspection and maintenance actions for your machines. Instruct all personnel in equipment inspection and maintenance actions and also in accident reporting/recording. Cybox phone representatives are available to answer any questions or concerns that you have.*

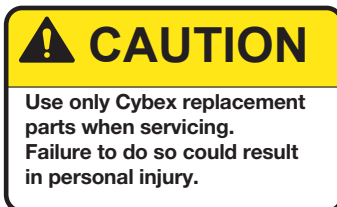

NOTE: *All inspections and repairs must be performed by trained service personnel only.*

Cybox will void warranty if non-Cybox replacement parts are used.

Daily Procedures

1. **Upholstery** - Wipe down all upholstery.
2. **Frames** - Wipe down all frames using a mild solution of warm water and car wash soap. Be sure to dry thoroughly. **AVOID** acid or chlorine based cleaners and also cleaners containing abrasives as these could scratch or damage the equipment.
3. **Chrome** - Clean chrome tubes, first using chrome polish and then using a car wax seal. Neutral cleaners with a pH between 5.5 and 8.5 are recommended. Be sure to dry thoroughly. **AVOID** acid or chlorine based cleaners and also cleaners containing abrasives as these could scratch or damage the equipment.

Weekly Procedures

1. Inspect all nuts and bolts for looseness. Tighten as required.
2. Inspect all labeling for readability. This includes instructional placards, warning and caution

decals. Replace all worn labeling immediately.



10 Trotter Drive Medway, MA 02053 • 508-533-4300 • FAX 508-533-5183
www.cybexintl.com • techhelp@cybexintl.com