



Jungle Gym® Dip Chin Tower
Owner's Manual
Strength Systems
Part Number 17150-999-4

Table of Contents

Safety

Safety Guidelines And Practices	3
Securing Equipment	6
Regular Maintenance Activities	7
Warnings and Cautions	8
Label Placement	9

Assembly

Machine Specifications	10
Environment and Storage	10
Assembly Procedures	10
Tools Required	11

Exercise

Intended Use	16
Instructions	16

Maintenance

Daily Procedures	18
Weekly Procedures	21
Yearly Procedures	23
Cable Adjustment	24
Belt Adjustment	25

Customer Service

Product Registration	26
Contacting Service	26
Ordering Parts	27
Return Material Authorization (RMA)	28
Damaged Parts	28

Cybox® and the Cybox logo are registered trademarks of Cybox International, Inc.
VR1® and its mark are registered trademarks of Cybox International, Inc.

DISCLAIMER: Cybox International, Inc., makes no representations or warranties regarding the contents of this manual. We reserve the right to revise this document at any time or to make changes to the product described within it without notice or obligation to notify any person of such revisions or changes.

© Copyright 2011, Cybox International, Inc. All rights reserved. Printed in the United States of America.

10 Trotter Drive Medway, MA 02053 • 508-533-4300 • FAX 508-533-5183 www.cyboxintl.com • techhelp@cyboxintl.com • 17150-999-4

Safety

Safety Guidelines And Practices

Cybox International partners with equipment owners to establish the safest and most effective setup of Cybox equipment. Cybox International urges each facility owner to carefully follow all safety precautions. Following these precautions are the best protection against personal injury or damage to equipment or facility.

The most important safety precaution is to maximize stability for every piece of equipment. The equipment should be securely anchored to the floor. It is imperative the floor be level.

Cybox recommends that all fitness equipment be used in a supervised area. It is recommended that the equipment be located in an access controlled area. Control is the responsibility of the owner. The extent of control is at the discretion of the owner.

It is the responsibility of the purchaser/owners of Cybox products to read and understand the owner's manual, and warning labels; as well as instruct all individuals, whether end users or supervising personnel, on proper usage of the equipment.

 Read the Owner's Manual carefully before assembling, servicing, or using the equipment. In an institutional environment, it is the facility owner's responsibility to properly instruct users on the proper operation of the equipment and to warn them of the potential hazards.



Follow and enforce the User Safety Precautions to protect both the user and the equipment. Keep children away from selectorized strength equipment. Teenagers or disabled users must be supervised.

Do not allow anyone, including trainers, to use equipment in a manner other than shown on the instructional placards located on every machine.

It is the responsibility of the facility owner and/or owner of the equipment to instruct users on proper operation of the equipment and review all labels.

 **WARNING:** *Serious injury or death could occur if these safety precautions are not followed:*

User Safety Precautions

-  Read all warnings posted on the machine. Warnings are posted on each machine to alert the user to potential problems. *Following warning labels will prevent injury or equipment damage.*
-  Read and understand warning labels and instructional placards prior to exercising. Obtain instruction prior to use. *Each machine has instructions posted on the equipment for proper use.*

- Use the selectorized and plate loaded machines as shown on placards. **DO NOT** modify the machine.
- Never pin the weights in an elevated position. **DO NOT** use the machine if found in this condition. *Seek assistance from floor staff. Weights pinned up have the potential to fall if the user pulls the pin. Floor staff should lower the weights to prevent potential problems.*
- Be certain that the weight pin is completely inserted (for selectorized strength equipment that employ weight stacks). *If the pin is not completely inserted the user may accidentally drop the weights if the pin falls out.*
- Never use dumbbells or other means to incrementally increase the weight resistance. Use only those means provided by the manufacturer for the equipment. *Altering the machine design by adding additional weight as with dumbbells or other means can injure the user, may damage the equipment, and will void the warranty.*
- Set up, anchor, and operate selectorized strength equipment on a solid level surface. *If the floor is not level the equipment is not stable.*
- **DO NOT** wear loose or dangling clothing or jewelry while using selectorized strength equipment. Stay clear of all moving components. *Loose clothing or dangling jewelry can become entangled in moving parts and potentially cause severe injury or damage.*
- Consult a physician prior to commencing an exercise program. If at any time during exercise you feel faint, dizzy or experience pain, stop and consult your physician. *Users must be responsible and cautious with the condition of their own health. Consulting a physician before beginning a program can alert the user to the personal risk if health is an issue.*
- Use a spotter for Free Weight equipment. *A spotter adds an additional level of safety.*
- **DO NOT** exceed the maximum specified user weight. *Too much weight on a machine may prevent it from proper function or damage the machine.*
- **DO NOT** use if equipment appears damaged or inoperable upon inspection. *If the equipment appears damaged or inoperable- contact the floor staff.*
- **DO NOT** attempt to fix a broken or jammed equipment. Notify floor staff. *It is the owner's responsibility to repair broken or jammed equipment.*
- **DO NOT** use if guards are missing or damaged. A missing or broken guard should be replaced by a qualified technician. *Guards prevent things from interfering with function.*
- **DO NOT** remove any labeling from equipment. Replace any damaged labels. Labels give users specific information and alerts. *Replacing damaged labels ensures users can read the labels for information provided.*

Facility Safety Precautions

-  Read the Owner's Manual carefully before assembling, servicing or using the equipment.
- It is the sole responsibility of the user/owner or facility operator to ensure that regular maintenance is performed.

- Inspect the equipment for worn or loose components prior to use. Tighten/replace any loose or worn components before to using. Pay close attention to belts, cables, grips or pulleys and their connections. Always look for potential problems in equipment condition. *Loose components should be tightened to function properly. Replacing worn components maintains the equipment is in the best condition for regular use.*
- To maximize stability, securely anchor each machine to the floor using the anchor holes provided in each machine. Each machine must be set up, anchored, and operated on a solid level surface.

Do not install equipment on an uneven surface!

DANGER !

Death or serious injury will occur if the following requirements are not met:



Cybox is not able to anchor the equipment due to local building codes. The owner is responsible for the actual anchoring of equipment. Consult with a professional contractor.

Use fasteners having a minimum of 500 lbs. tensile capacity -- Cybox recommends 3/8" grade 2 bolts or better.

If legs/frame does not contact surface, DO NOT pull down with anchors. Shim any leg or frame not in contact with surface using flat washers.

- Ensure that all users are properly trained on how to use the equipment.
- Verify there is enough room for safe access and operation of the equipment. Spacing requirements for each piece of equipment vary depending on placement. The Assembly section gives equipment dimensions but it is up to the facility to verify there is clearance between and around each machine to operate without interference.
- Perform regular maintenance checks on the equipment as detailed in the Maintenance section of this manual. Inspect all areas most susceptible to wear, including, (but not limited to) cables, pulleys, belts, and grips.
- Immediately replace worn or damaged components. If unable to immediately replace worn or damaged components then remove from service until the repair is made.
- Use only Cybox supplied components to maintain/repair the equipment.
- Keep a repair log of all maintenance activities.
- Display the Facility Safety Sign so it is visible and prominent.

Securing Equipment

Do not use machine until it is properly anchored.

The machine has holes in the feet, which allow for ease in anchoring to the floor. All anchoring holes must be used to maximize stability. Equipment must be secured to a solid, level surface to eliminate rocking, tipping, or falling over due to incorrect usage and misuse.

The solid, level surface should not deviate more than 1/8" over a 10' distance or as defined and required by local building and architectural codes.

Anchoring of equipment must be completed by a qualified licensed contractor.

Due to the wide variation of flooring on which machines may be anchored or installed, verify anchoring method and anchoring fasteners with a qualified and licensed contractor.

A minimum pull out force of 220 lbs/100 kgs is required for each anchor position.

PROPER USAGE

Use equipment only as described in the manual or on the placards located on each machine. Failing to follow proper instructions may result in injury.



WARNING: *Serious injury or death could occur if the following warnings are not enforced: DO NOT Lean Against or Pull On the framework, weight stack, or any component, whether machine is at rest or in use. Inappropriate or improper use may result in injury to users or third parties (bystanders)*



STANDARD COMPLIANCE

Cybox products meets applicable ASTM and EN Standards.

Regular Maintenance Activities

Preventative maintenance activities must be performed to maintain normal and safe operation of your equipment. Keeping a log sheet of all maintenance actions will assist you in staying current with all preventative maintenance activities. The preventative maintenance actions are described in detail in the maintenance section of this manual. Briefly, they include:

Daily

Clean upholstery.

Weekly

- Inspect all nuts and bolts for looseness. Tighten as required.
- Inspect all cables and belts for damage or wear. If a cable or belt is worn or damaged, immediately discontinue use until cable or belt has been replaced.
- Check for worn handles, worn snap links, and worn warning labeling. Replace all worn parts immediately.
- Inspect for loose or worn grips. Replace all loose or worn grips immediately.
- Inspect weight stacks for proper alignment and operation. Correct all improper alignment and operation issues immediately.
- Lubricate guide rods using automotive engine oil only.

Yearly

Replace all cables and belts at least annually.

Warnings and Cautions

Warning decals indicate a potentially hazardous situation that could result in death or serious injury if the precautions are not observed.

Caution decals indicate a potentially hazardous situation, which, if not avoided, could result in minor or moderate injury.

The diagram following the decals show where each decal is located.

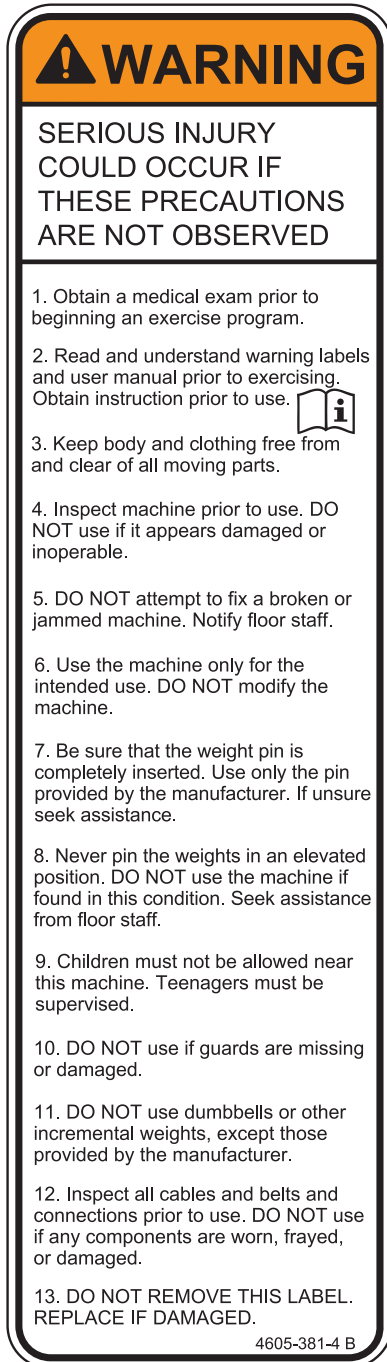

Label Placement

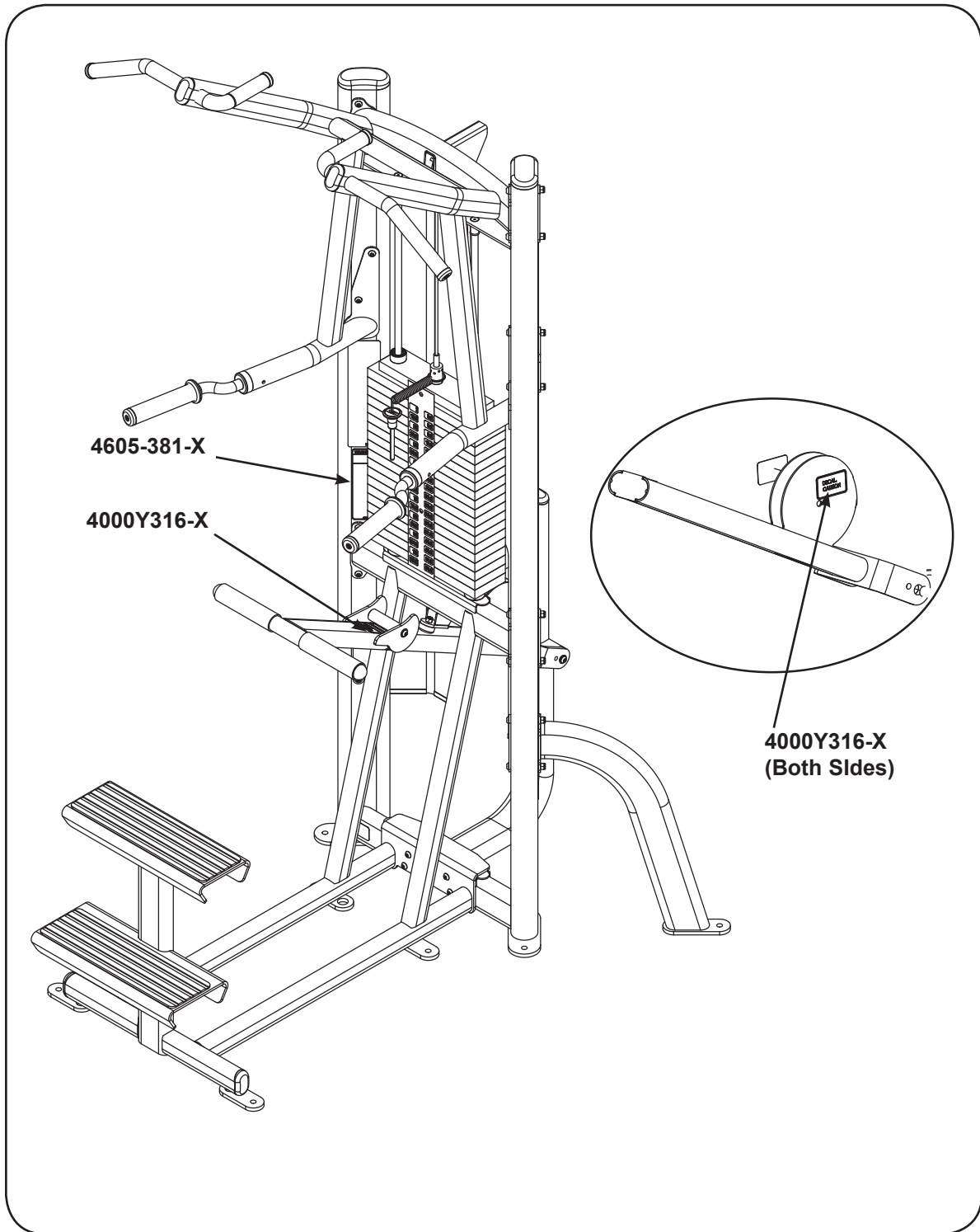

Assembly

Machine Specifications

Total Weight and Size Jungle Gym 17150 Dip Chin and Tower

Weight	Machine Dimensions at Rest	Machine Dimensions in Use
548 Lbs	59" L x 49" W x 98" H	Same
259 Kg	150 cm L x 124 cm W x 249 cm H	Same

Environment and Storage

Static Electricity

To reduce static electricity increase the humidity.

Humidity

The unit is designed to function normally in an environment with a relative humidity range of 30% to 75%. The unit can be shipped and stored in an environment with a relative humidity range of 10% to 90%.

Temperature

The unit is designed to function normally in an environment with an ambient temperature range of 50° F (10° C) to 104° F (40° C). The unit can be shipped and stored in an environment with a relative humidity range of 10% to 90%.

Do not install, use, or store the unit in an area of high humidity, such as near a steam room, sauna, indoor pool or outdoors. Extensive exposure to water vapor, chlorine and/or bromine could adversely affect the equipment.

Assembly Procedures

Two people will be required for this procedure.

 Read and understand all instructions thoroughly before assembling this unit. Check all items carefully. If there is damage, see the Customer Service section of this manual for proper procedure to return, replace, or reorder parts.

Tools Required

Two people will be required for this procedure. It is the responsibility of the facility owner/owner of the equipment to ensure that there is appropriate clearance around each machine to allow for safe use and passage.

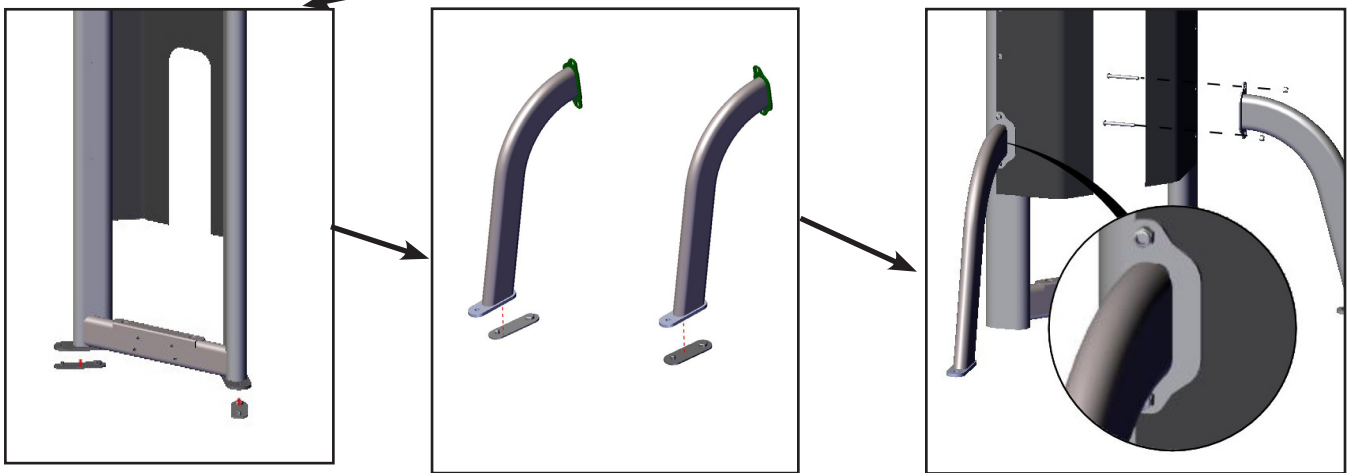
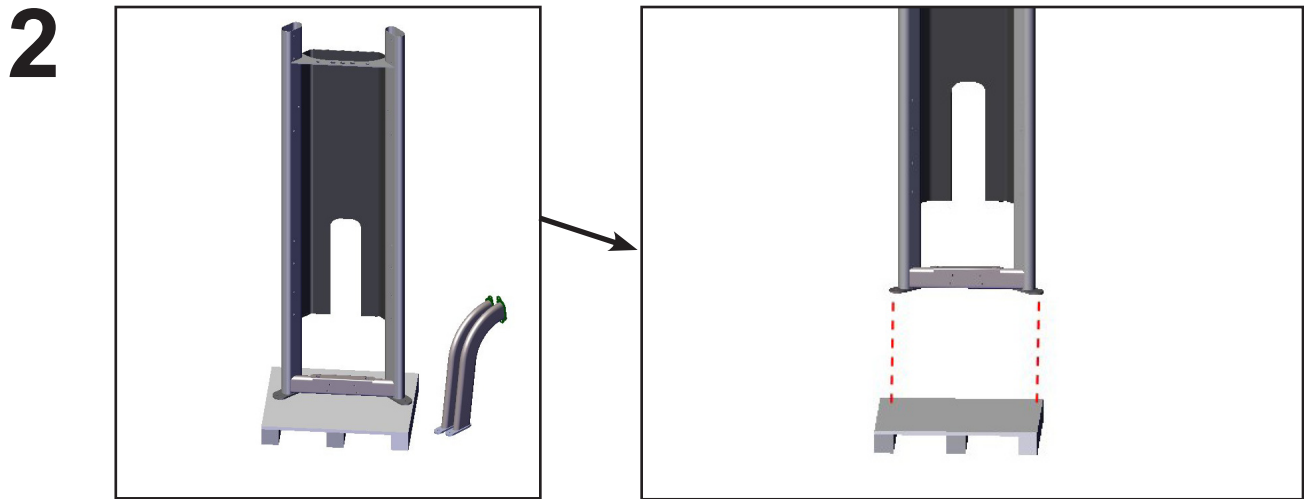
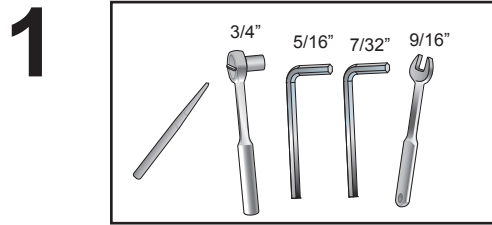

3

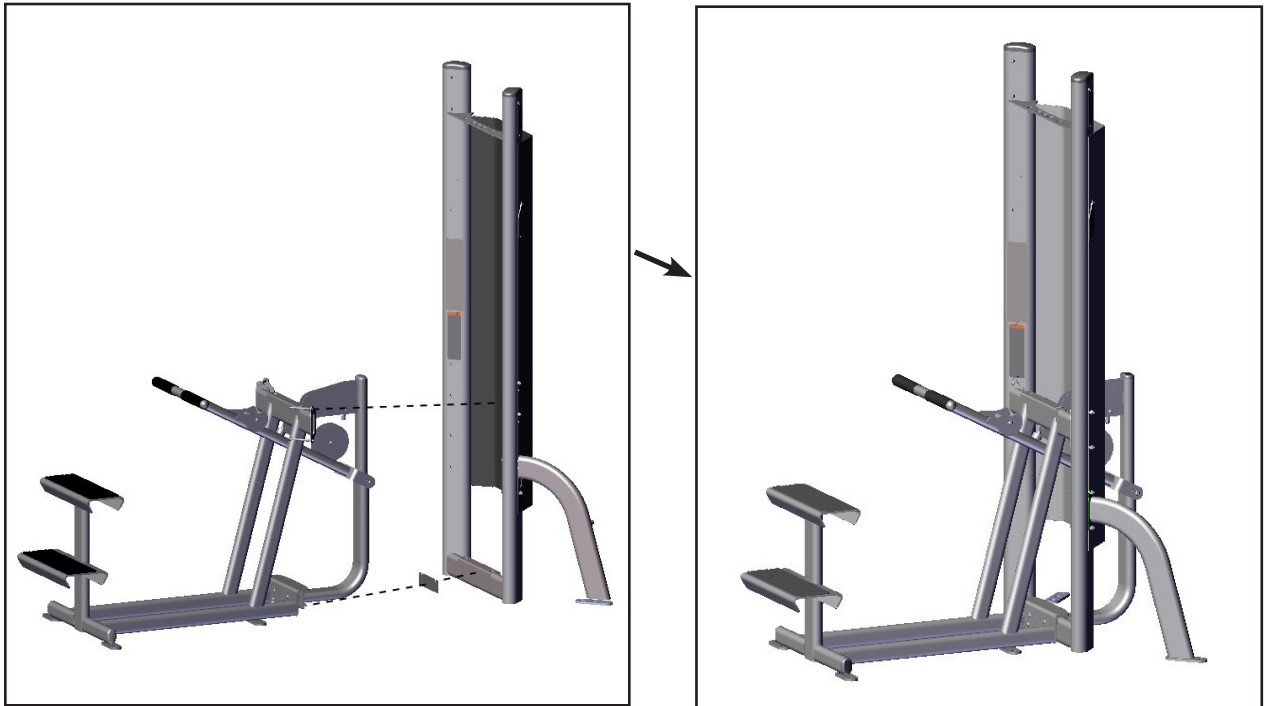

4

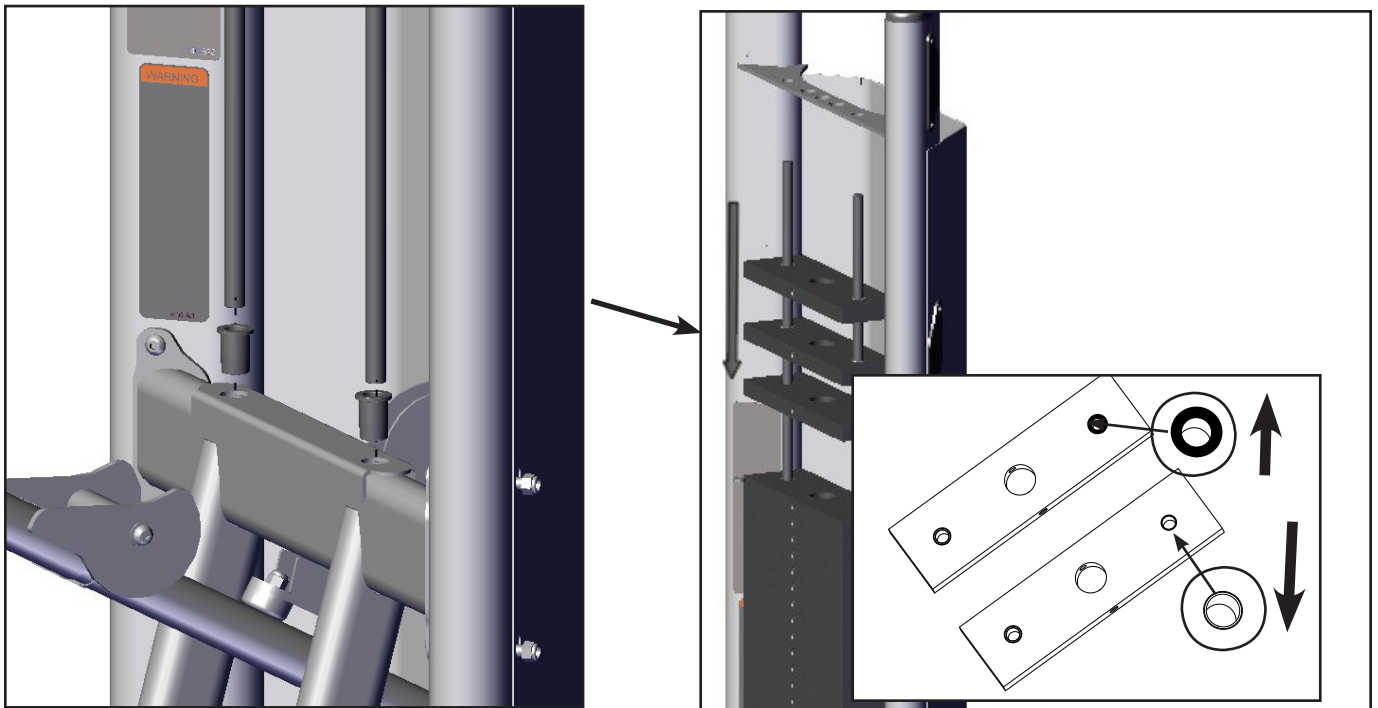

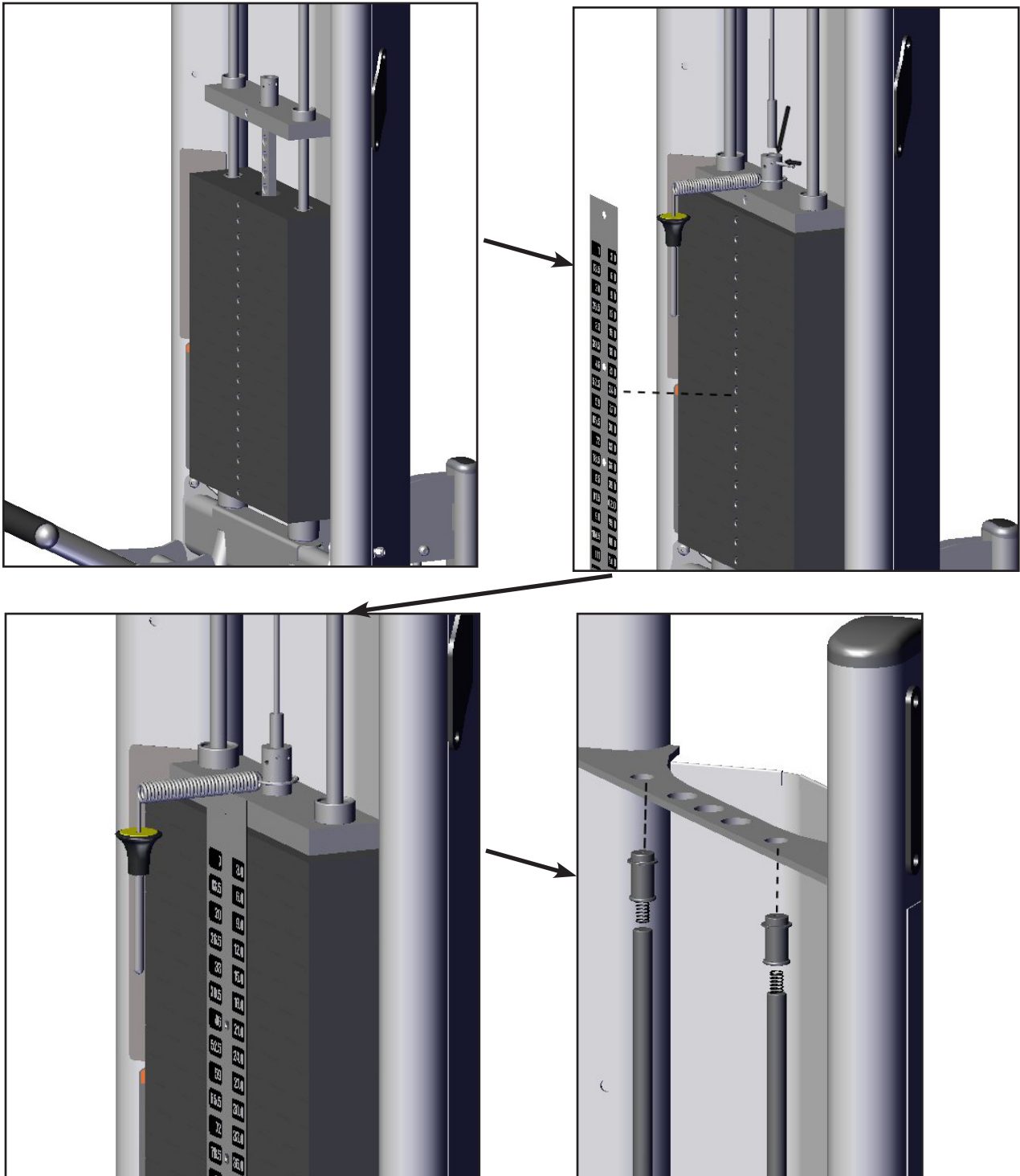

5

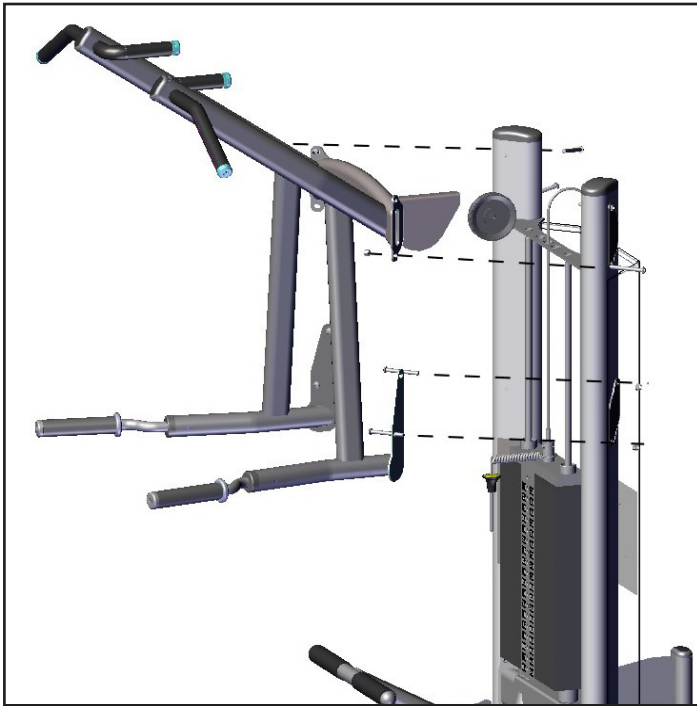



Exercise

Intended Use

The intended commercial use of this machine is to aid exercise and improve general physical fitness.

Instructions



Read and understand all instructions and warnings prior to using this machine in the Safety section of the Owner's Manual.

All adjustment points on the machine have yellow handles or knobs.

1. Select desired assist.
2. Select desired grip.
3. Step on foot bar.

NOTE: *If assist is not desired, lift foot bar up.*

4. Lift/lower body in smooth controlled movements.



CAUTION: *Serious injury can result if precautions are not followed. Use equipment only as described in placards located on each machine. Failure to use in the manner depicted can result in injury.*

DIP CHIN

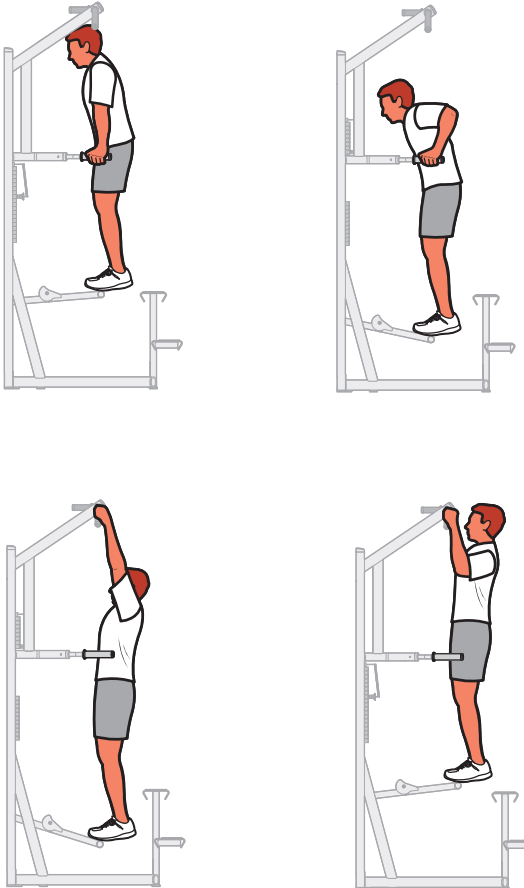

The illustrations show a person performing two exercises on a dip/chin tower. The top row shows the 'DIP' exercise: the person stands on the platform, grips the handles, and lowers their body. The bottom row shows the 'CHIN UP' exercise: the person stands on the platform, grips the handles, and pulls their chin up to the bar.

**START/FINISH
DIP**

**START/FINISH
CHIN UP**

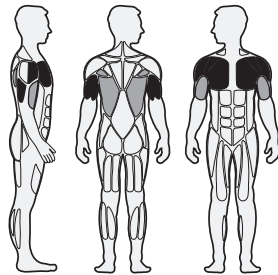

Three anatomical diagrams of the human body are shown. The first is a side view with the pectoralis and anterior deltoid muscles shaded. The second is a front view with the pectoralis, anterior deltoid, and triceps muscles shaded. The third is a front view with the latissimus dorsi, teres major, biceps, and lower trapezius muscles shaded.

Motions Developed
Dip - Shoulder Flexion, Adduction Elbow Extension
Chin Up - Shoulder Adduction and Elbow Flexion

Muscles Used

- **Dip** - Pectoralis, Anterior Deltoid, Triceps
- **Chin Up** - Latissimus Dorsi, Teres Major, Biceps, Lower Trapezius, Rhomboid

Maintenance

All preventive maintenance activities must be performed on a regular basis. Performing routine preventive maintenance actions can aid in providing safe, trouble-free operation of all Cybex Strength Systems equipment.

Cybex is not responsible for performing regular inspection and maintenance actions for your machines. Instruct all personnel in equipment inspection and maintenance actions and also in accident reporting/recording. Cybex representatives are available to answer any questions that you may have.

All inspections and repairs must be performed by trained service personnel only. Cybex will void warranty if non-Cybex replacement parts are used.

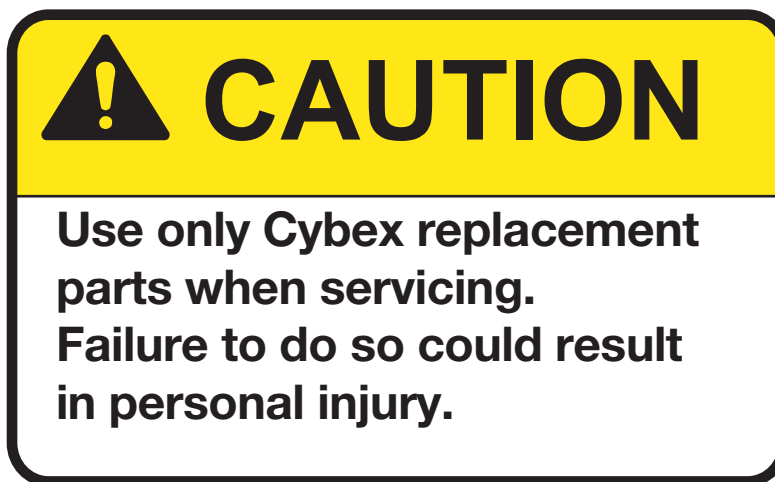

Daily Procedures

When using strong cleaning agents such as rubbing alcohol or bleach, it is advisable to first test in an inconspicuous area. Other cleaning agents may contain harsh or unknown solvents and are subject to formula changes by the product manufacturer without notice. Should you desire to use other cleaning agents, carefully try them in an inconspicuous area to determine potential damage to the material. Never use harsh solvents or cleaners which are intended for industrial applications. To clean stained or soiled areas, a soft white cloth is recommended. Avoid use of paper towels.

Cleaning products may be harmful/irritating to your skin, eyes, etc. Use protective gloves and eye protection. **Do Not** inhale or swallow any cleaning product. Protect surrounding area/clothing from exposure. Use in well ventilated area. Follow all product manufacturer's warnings. CYBEX and its vendors cannot be held responsible for damage or injuries resulting from the use or misuse of cleaning products.

Clean Upholstery

If	Then
Light Soiling	<ol style="list-style-type: none"> 1. Prepare a solution of 10% household liquid soap and warm water. 2. Apply with a soft damp cloth. 3. If necessary, apply a solution of liquid cleanser with a soft bristle brush. 4. Dampen a clean soft cloth in water and wipe residue away.
More Difficult Stains	<ol style="list-style-type: none"> 1. Prepare a solution of 10% household bleach (sodium hypochlorite) and 90% water. Dampen a soft white cloth in the solution. 2. Rub gently on the stained area. 3. Dampen a clean soft cloth in water and rinse area. 4. If stains are still present, a full strength household bleach may be used. Allow bleach to puddle on the affected area or apply with a bleached-soaked cloth for approximately 30 minutes. Dampen a clean soft cloth in water, and rinse area to remove any remaining bleach concentration.
More Difficult Stains (Alternative Method)	<ol style="list-style-type: none"> 1. Dampen a soft white cloth with rubbing alcohol. 2. Gently rub stained area. 3. Dampen a clean soft cloth in water and rinse area.
Restoring Luster	<ol style="list-style-type: none"> 1. Apply a light coat of furniture wax for 30 seconds. 2. Lightly rub area using a clean white cloth.

Clean Frames

Wipe down all frames using a mild solution of warm water and car wash soap. Be sure to dry thoroughly. **AVOID** acid or chlorine based cleaners and also cleaners containing abrasives as these could scratch or damage the equipment.

Clean Chrome

Clean chrome tubes, first using chrome polish and then using a car wax seal. Neutral cleaners with a pH between 5.5 and 8.5 are recommended. Be sure to dry thoroughly. AVOID acid or chlorine based cleaners and also cleaners containing abrasives as these could scratch or damage the equipment.

Guidelines for cleaning front panel:

Use clean soft cloths or sponges for application of cleaners and again for washing and rinsing. Follow up each application with warm water rinse.

- **DO NOT** use abrasives or high alkaline cleaners.
- **DO NOT** leave cleaners on for long periods, wash immediately.
- **DO NOT** apply cleaners in direct sunlight or at elevated temperatures.
- **DO NOT** use scrapers, squeegees, or razors.
- **DO NOT** clean with gasoline.

Compatible Cleaners and Detergents:

- Formula 409
- Top Job
- Joy
- Palmolive
- Windex with Ammonia D

To Minimize Fine or Hairline Scratches:

Mild automotive polish applied and removed with a soft clean cloth will help fill scratches.

Suggested Polishes:

- Johnson Paste Wax
- Mirror Glaze #10 Plastic Polish (by Mirror Bright Polish Co.)
- Novus Plastics Polish #1, #2 (By Novus Inc.)

Weekly Procedures

Inspect All Nuts and Bolts

Tighten all loose nuts and bolts as required.







WARNING: *Serious injury or death may result if the following precautions are not followed. Replace all worn cables and belts. Worn cables and belts can fail if not replaced.*



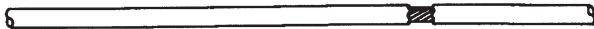



Inspect cables and belts

Inspect all cables and belts for wear or damage and proper tension. When inspecting cables and belts, run fingers on the cable or belt, paying particular attention to bends in cables and attachment points. The following conditions may indicate a worn cable:

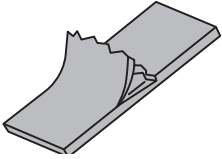
Cables

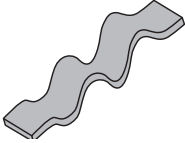
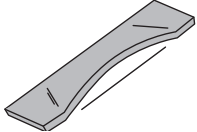
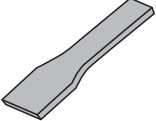
Condition of Cable	Diagram
A tear or crack in the cable sheath that exposes the cable	 <p>A horizontal line representing a cable. In the middle, there is a small gap where the sheath is missing, exposing the inner core. The gap is shaded with diagonal lines to indicate the exposed interior.</p>
A kink in the cable	 <p>A horizontal line representing a cable. It has a sharp V-shaped bend or kink in the middle, where the sheath is compressed and folded back on itself.</p>
A curled sheath	 <p>A horizontal line representing a cable. The sheath is wavy and curved upwards in the middle, indicating it is stretched and curled.</p>
Necking - A stretched cable sheath	 <p>A horizontal line representing a cable. The middle section is significantly thinner than the ends, indicating the sheath has stretched and become thin.</p>

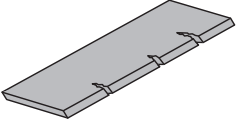
Belts

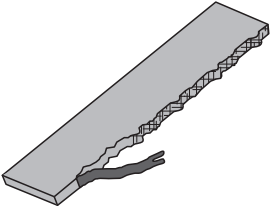
Condition of Belt	3D View	3D or Side View
Peeling of the belt's skin.		
Wave in belt		
Belt is necked down (narrow section)	<p data-bbox="654 632 984 779">Replace belt if any section is over 1/32" (.03) narrower than the rest of belt</p> 	<p data-bbox="1000 632 1498 737">Examine edge of belt (both sides). Replace belt if any section is narrower than the rest.</p> 
Cracks or splits		
One or more strands of kevlar is hanging out, or if there is a significant amount of frayed kevlar.		



CAUTION: *Personal injury or property damage may occur if the following precautions are not followed. Do not use if less than 1/8" of material remains to the edge. Replace all worn handles immediately. Failure to replace worn handles can result in injury or property damage.*

Inspect bars and handles for wear, paying particular attention to tab area connection points.

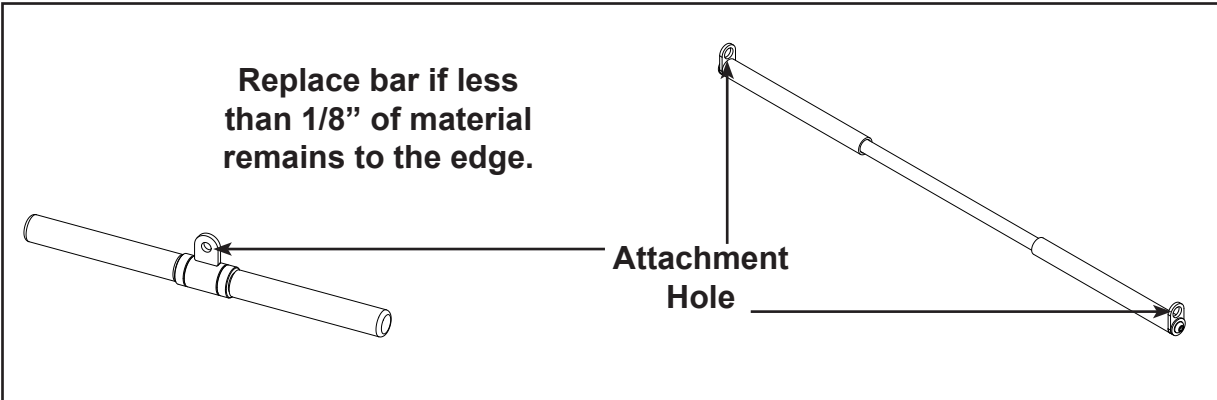

Inspection	Action
Inspect bars and handles for wear, paying particular attention to tab area connection points.	Replace all worn handles immediately.
Inspect snap links for proper latching (indicates wear).	Replace all loose or worn grips immediately.
Inspect all labeling for readability, including instructional placards, warning and caution decals.	Replace all worn labeling immediately.
Inspect all weight stacks for proper alignment and operation.	Correct all improper alignment and operation issues immediately.
Inspect guide rods for lubrication.	Wipe Weight Stack Guide Rods clean over entire length. Lubricate with a light coat of medium weight automotive engine oil.

Yearly Procedures

Replace all cables and belts annually

Cable Adjustment

Tools Required

9/16" Wrench (2)

Four types of cable tension adjustment are used on Cybox Strength Systems:

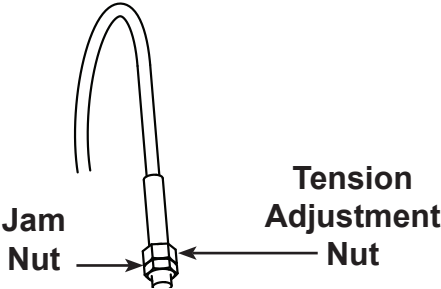
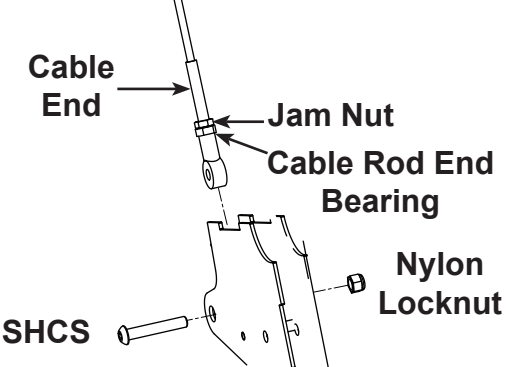
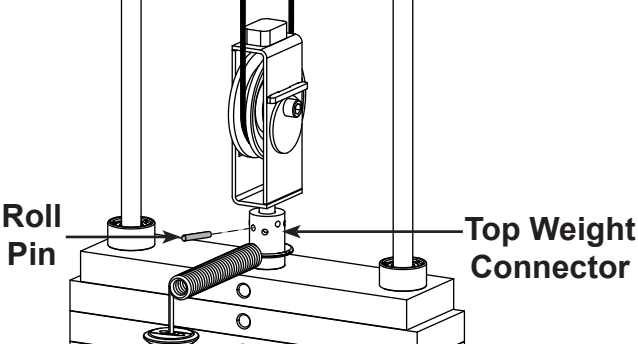
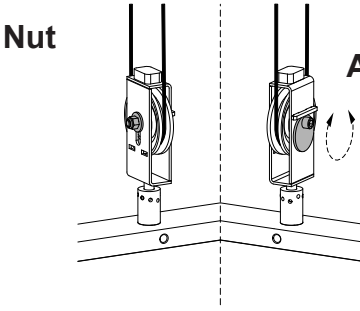
Cable Adjustment	Description	Diagram
Jam Nut Adjustment	This type of adjustment uses a jam nut and a tension adjustment nut at the cable cam end as the primary adjustment. The other end of the cable usually contains a roll pin adjustment.	 <p>The diagram shows a cable with a curved end. A 'Jam Nut' is positioned on the cable, and a 'Tension Adjustment Nut' is positioned on the other side of the cable. Arrows point to each nut.</p>
Rod End Adjustment	This type of adjustment uses a socket head cap screw (SHCS) securing a cable rod end bearing to the machine. Primary adjustment is by turning the rod end bearing. The other end of the cable usually contains a roll pin cable adjustment.	 <p>The diagram shows a cable rod end bearing being secured to a machine. A 'Cable End' is shown with a 'Jam Nut' and a 'Cable Rod End Bearing'. A 'SHCS' (socket head cap screw) is shown being inserted into the bearing. A 'Nylon Locknut' is also shown.</p>
Roll Pin Adjustment	This type of adjustment uses a roll pin and series of holes in the weight stack top weight connector.	 <p>The diagram shows a weight stack with a 'Top Weight Connector'. A 'Roll Pin' is shown being inserted into the connector.</p>
Cam End Adjustment	This type of adjustment uses an adjustment bolt on the pulley bracket. Loosen nut and rotate cam bolt to adjust cable.	 <p>The diagram shows a pulley bracket with a 'Nut' and a 'Cam Bolt Adjustment'. The cam bolt is shown being rotated to adjust the cable.</p>

Belt Adjustment

Tools Required

- 7/32" Wrench
- Torque wrench (lbs-in)

Belt Adjustment	Action
Loose Belt	<ol style="list-style-type: none">1. Using a 7/32" Allen wrench loose set screws.2. Pull belt tight.3. Secure belt in place with set screws.4. Torque set screws to 300-350 lb-in.5. Verify that the belt is moving smoothly and is routed straight from the top pulley bracket to the to weight belt clamp

Customer Service

Product Registration

To register product do the following:

1. Visit www.cyboxintl.com.
2. Locate Product Registration in the Support section.
3. Fill out form completely.
4. Click the Submit button to register product.

Contacting Service

Hours of phone service are Monday through Friday from 8:30 a.m. to 6:00 p.m. Eastern Standard Time.

For Cybox customers living in the USA, contact Cybox Customer Service at 888-462-9239.

For Cybox customers living outside the USA, contact Cybox Customer Service at 508-533-4300 or fax 508-533-5183. email address internationaltechhelp@cyboxintl.com

Find information on the web at www.cyboxintl.com or email at techhelp@cyboxintl.com.

Ordering Parts

To order parts online go to www.cybexintl.com. Select Support > Parts / Ordering. In the left navigation panel, click Parts Diagrams - Current Products. Select from the drop down boxes.

To speak with a customer service representative, call 888-462-9239 (for customers living within the USA) or 508-533-4300 (for customers outside the USA). You may also contact us through email at techhelp@cybexintl.com.

The following information located on the serial number decal will assist our Cybex representatives in serving you.

- Unit Serial Number, Product Name and Model Number

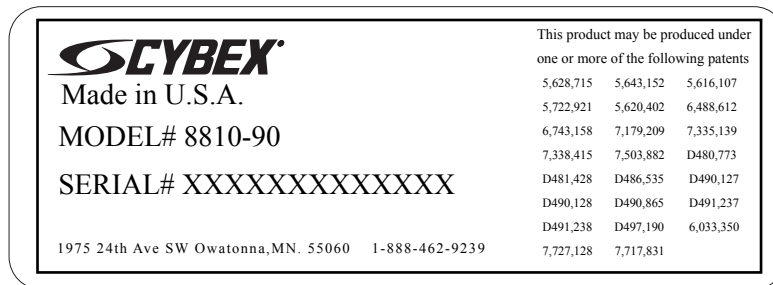

- Part Description and Part Number if you have it. All parts can be found on the web at www.cybexintl.com
- Shipping Address
- Contact Name
- Include a description of the problem.

In addition to your shipping address and contact name, your account number is helpful but not required. You may also fax orders to 508-533-5183.

Return Material Authorization (RMA)

The Return Material Authorization (RMA) system is used when returning material for placement, repair or credit. The system assures that returned materials are properly handled and analyzed. Follow the following procedures carefully.

Contact your authorized Cybox dealer on all warranty-related matters. Your local Cybox dealer will request a RMA from Cybox, if applicable. Under no circumstances will defective parts or equipment be accepted by Cybox without proper RMA and an Automated Return Service (ARS) label.

Please contact Cybox Customer Service for the return of any item that is defective.

Provide the technician with a detailed description of the problem you are having or the defect in the item you wish to return. Provide the model and serial number of your Cybox equipment.

At Cybox's discretion, the technician may request that you return the problem part(s) to Cybox for evaluation and repair or replacement. The technician will assign you a RMA number and will send you an ARS label. The ARS label and the RMA numbers must be clearly displayed on the outside of the package that contains the item(s) to be returned. Include the description of the problem, the serial number of the equipment and the name and address of the owner in the package along with the part(s).

Merchandise returned without an RMA number on the outside of the package or shipments sent COD will not be accepted by the Cybox receiving department.

Damaged Parts

Materials damaged in shipment should not be returned for credit. Shipping damages are the responsibility of the carrier (UPS, Federal Express, trucking companies, etc.)

Apparent Damage

Upon receipt of your shipment, check all items carefully. Any damage seen with a visual check must be noted on the freight bill and signed by the carrier's agent. Failure to do so will result in the carriers refusal to honor your damage claim. The carrier will provide you with the required forms for filing such claims.

Concealed Damage

Damage not seen with a visual check upon receipt of a shipment but notices later must be reported to the carrier as soon as possible. Upon discovery of the damage, a written or phone request to the carrier asking them to perform an inspection of the materials must be made within ten days of the delivery date. Keep all shipping containers and packing materials as they will be needed in the inspection process. The carrier will provide you with an inspection report and the necessary forms for filing a concealed damage claim. Concealed damage claim is the carrier's responsibility.



10 Trotter Drive Medway, MA 02053 • 508-533-4300 • FAX 508-533-5183
www.cybexintl.com • techhelp@cybexintl.com