



Cybex 625A/625AT Arc Trainer®
Owner's Manual
Cardiovascular Systems
Part Number 5625-4 A

Table of Contents

| | | | |
|---|----|---|----|
| FCC Compliance Information | 3 | Quick Operation Guide | 67 |
| Safety | | Detailed Operation Guide | 67 |
| Ground and Voltage Information | 4 | Program Selection | 69 |
| Important Safety Instructions | 4 | Data Readouts | 70 |
| Warning and Caution Decals | 6 | Heart Rate Indicator | 71 |
| CSAFE Port | 9 | Maintenance | |
| Assembly | | Warnings | 72 |
| Specifications - 625A | 10 | Cleaning Unit | 73 |
| 625A Top View | 11 | Preventive Maintenance Activities | 73 |
| Specifications - 625AT | 12 | Remove Access Cover | 74 |
| 625AT Top View | 13 | Drive Belts | 75 |
| Environment and Storage | 13 | Rechargeable Battery | 75 |
| Warning and Caution Decals | 14 | Attach Access Cover | 76 |
| Choosing and Preparing Site | 14 | Recommended Service Schedule | 76 |
| Electrical Power Requirements | 14 | Customer Service | |
| 625A Assembly | 15 | Product Registration | 78 |
| 625AT Assembly | 26 | Contacting Service | 78 |
| Setup | 41 | Ordering Parts | 78 |
| Transfer settings to other units (optional) | 42 | Serial Number | 79 |
| A/V Config and FM Radio Presets | 45 | Return Material Authorization (RMA) | 79 |
| E3 View Monitor Controls | 50 | Damaged Parts | 80 |
| E3 View Monitor Setup | 51 | Appendix - Program Overviews | |
| Testing Operation | 59 | P1: Weight Loss 1 | 81 |
| Operation | | P2: Weight Loss 2 | 82 |
| Intended Use | 60 | P3: Weight Loss 3 | 83 |
| Terms Used | 60 | P4: Cardio 1 | 84 |
| User Control Symbols Used | 61 | P5: Cardio 2 | 85 |
| Console Display | 62 | P6: Cardio 3 | 86 |
| User Controls | 63 | P7: Strength 1 | 87 |
| Mount and Dismount | 65 | P8: Strength 2 | 88 |
| Emergency Dismount | 65 | P9: Heartrate Control | 89 |
| Range of Motion | 66 | | |

Cybox® and the Cybox logo are registered trademarks of Cybox International, Inc. Polar® is a registered trademark of Polar Electro Inc. iPod, iPhone, and iPad are trademarks of Apple Inc., registered in the U.S. and other countries.

DISCLAIMER: Cybox International, Inc., makes no representations or warranties regarding the contents of this manual. We reserve the right to revise this document at any time or to make changes to the product described within it without notice or obligation to notify any person of such revisions or changes.

© Copyright 2014, Cybox International, Inc. All rights reserved. Printed in the United States of America.

10 Trotter Drive Medway, MA 02053 • 508-533-4300 • FAX 508-533-5183 • www.cyboxintl.com • 5625-4 A • July 2014

FCC Compliance Information

Changes or modifications to this unit not expressly approved by the party responsible for compliance could void the user's authority to operate the equipment!

This equipment has been tested and found to comply with the limits for a Class B digital device, pursuant to part 15 of the FCC Rules. These limits are designed to provide reasonable protection against harmful interference in a residential installation. This equipment generates, uses and can radiate radio frequency energy and, if not installed and used in accordance with the instructions, may cause harmful interference to radio communications. However, there is no guarantee that interference will not occur in a particular installation. If this equipment does cause harmful interference to radio or television reception, which can be determined by turning the equipment off and on, the user is encouraged to try to correct the interference by one or more of the following measures:

- Reorient or relocate the receiving antenna.
- Increase the separation between the equipment and receiver.
- Connect the equipment into an outlet on a circuit different from that to which the receiver is connected.
- Consult the dealer or an experienced radio/TV technician for help.

Safety

 Read all instructions and warnings before using.

Ground and Voltage Information

AC Power Adapter is optional.

 **DANGER:** *Death or serious injury can occur. To avoid death or injury the following precautions must be observed. Equipment must be properly grounded. Check with a qualified electrician or service provider to verify the unit is properly grounded. Improper connection of equipment grounding can result in electric shock.*

Cybox is not responsible for injuries or damages as a result of cord or plug modification.

- Verify voltage requirements of unit match local voltage requirements.
- Verify unit outlet is the same configuration as the plug.

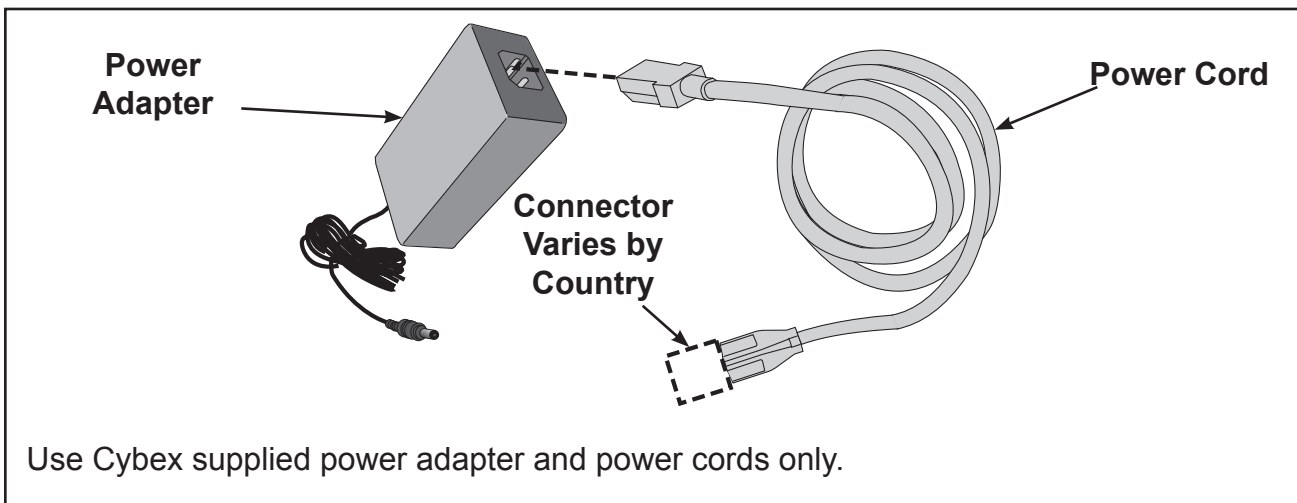

Important Safety Instructions

(Save These Instructions)

 **DANGER:** *Death or serious injury can occur. To avoid death or injury the following precautions must be observed. Always unplug this unit from the electrical outlet before cleaning. Unplugging equipment reduces risk for shock.*

User Safety Precautions

- KEEP ALL CHILDREN 12 AND UNDER AWAY! Teenagers or disabled must be supervised.
- Obtain a medical exam before beginning any exercise program.
- Stop exercising if feeling faint, dizzy, or experiencing pain and consult your physician.
- Obtain instruction before using.

-  Read and understand all warnings posted on the unit before using.
- Use the handrails for support and to maintain balance.
- Wait until foot plates come to a complete stop before dismounting.
- Keep foot plate surface clean and dry.
- DO NOT wear loose or dangling clothing while using.
- Keep all body parts and other items free and clear of moving parts.
- DO NOT use unit if user exceeds 400 lbs. (180 kg). This is the rated maximum user weight.
- Report any malfunctions, damage or repairs to the facility.
- Replace any warning labels if damaged, worn or illegible.

Facility Safety Precautions

It is the sole responsibility of the user/owner or facility operator to ensure that regular maintenance is performed.

- Enforce all user and safety precautions.
- Read and understand the Owner's Manual completely before assembling, servicing or using unit.
- Verify all users are properly trained on using the equipment.
- Do not use unit outdoors.
- Verify that each unit is setup, leveled and operated on a solid level surface. Do not install equipment on an uneven surface.
- Verify there is enough room for safe access and operation of unit.
- Use Cybex AC power adapters only.
- Do not use the optional power adapter in damp or wet locations.
- Do not use the unit if: (1) the unit is plugged into an optional power adapter that has a damaged cord; (2) the unit is not working properly or (3) if the unit has been dropped or damaged. Seek service from a qualified technician.
- EQUIPMENT is not suitable for use in the presence of aerosol (spray), FLAMMABLE ANAESTHETIC MIXTURE WITH AIR or WITH OXYGEN or NITROUS OXIDE.
- Perform regular maintenance checks on unit. Performance level can be maintained only if examined regularly. Pay close attention to all areas most susceptible to wear, including (but not limited to) cables, pulleys, belts and grips.
- Replace any warning labels if damaged, worn, or illegible.
- Immediately replace worn or damaged components. If unable to immediately replace worn or damaged components, then remove unit from service until repair is made.
- Do not attempt electrical or mechanical repairs. Seek qualified repair personnel when servicing. If you live in the USA, contact Cybex Customer Service at 888-462-9239. If you live outside the USA, contact Cybex Customer Service at 508-533-4300.
- Use only Cybex supplied components to maintain/repair unit.
- Keep a repair log of all maintenance activities.
- Disconnect the optional power adapter before servicing unit.
- Do not use attachments unless recommended for the unit by Cybex.
- The unit may generate electromagnetic or other forms of interference, or it may be affected by interference from other equipment nearby. If this is suspected, take precautions by separating the equipment or otherwise shielding it to avoid such interference.

Warning and Caution Decals

To replace any worn or damaged decals do one of the following: Visit www.cyboxintl.com to shop for parts online, fax orders to 508-533-5183 or contact Cybox Customer Service at 888-462-9239. If you are located outside of the USA, call 508-533-4300. For location or part number of labels, see the parts list and exploded-view diagram on the Cybox web site at www.cyboxintl.com.

Warning decals indicate a potentially hazardous situation which, if not avoided, could result in death or serious injury.

Carefully read and understand the following caution and warning labels before using the unit.

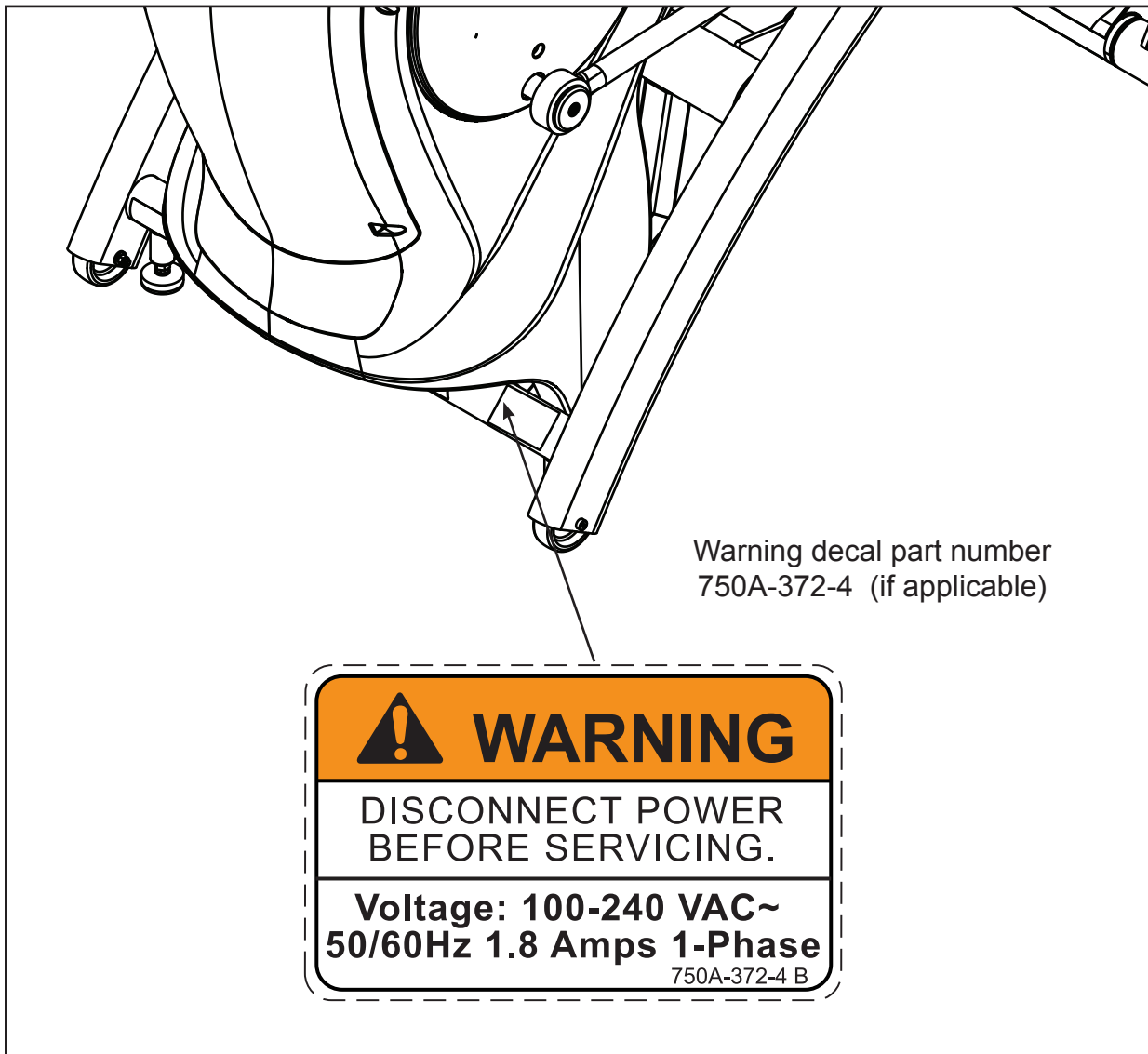

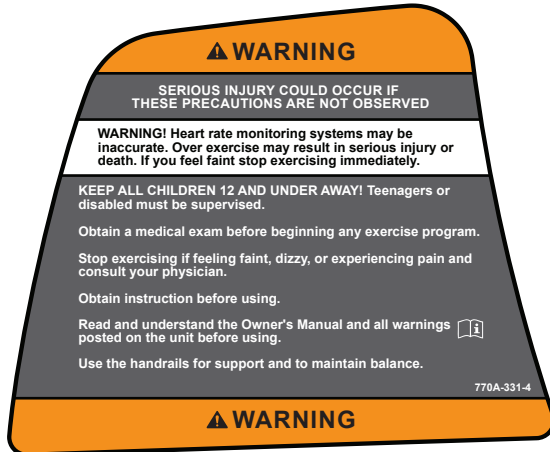

Warning decal part number 770A-331-4



Warning decal part number 770A-332-4

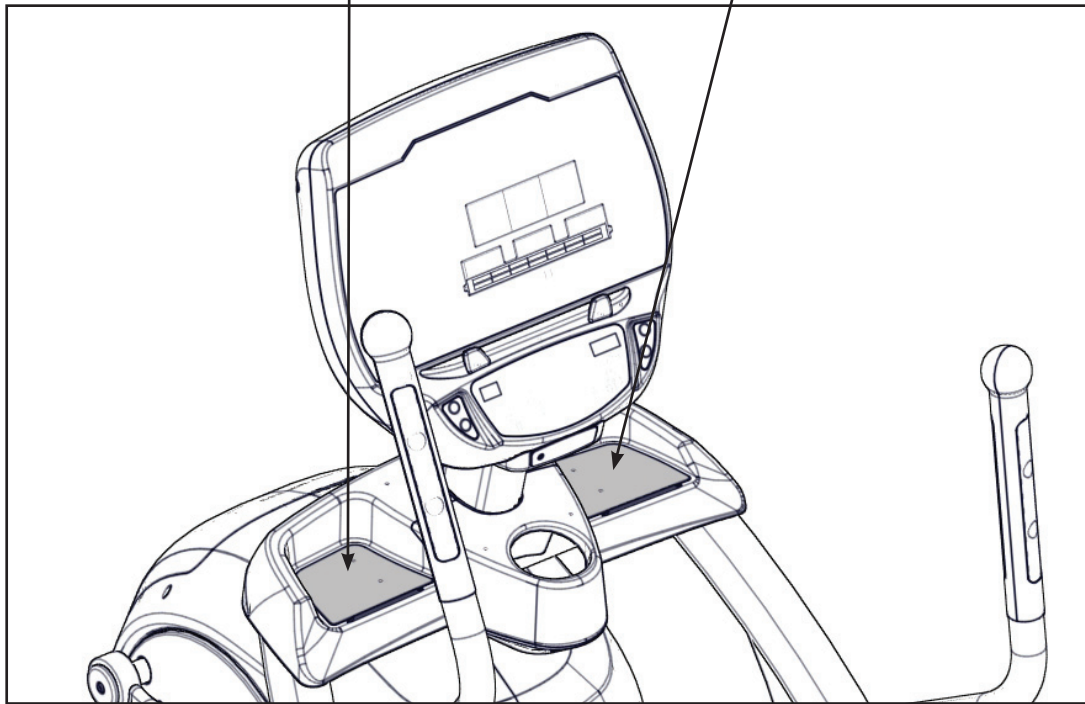

625AT Shown

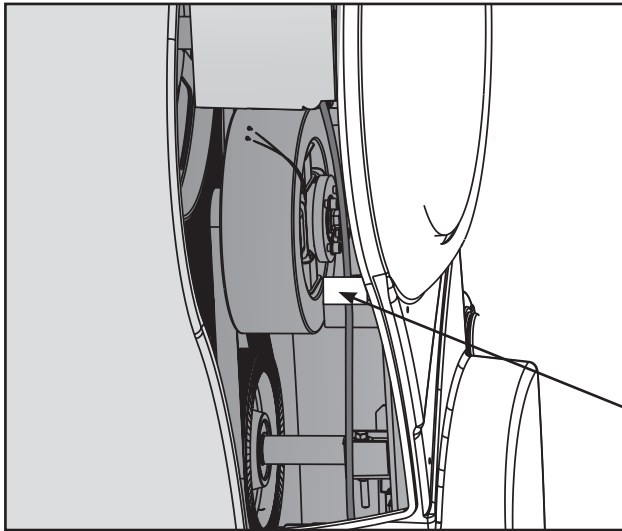

Warning decal part number DE-17155-4

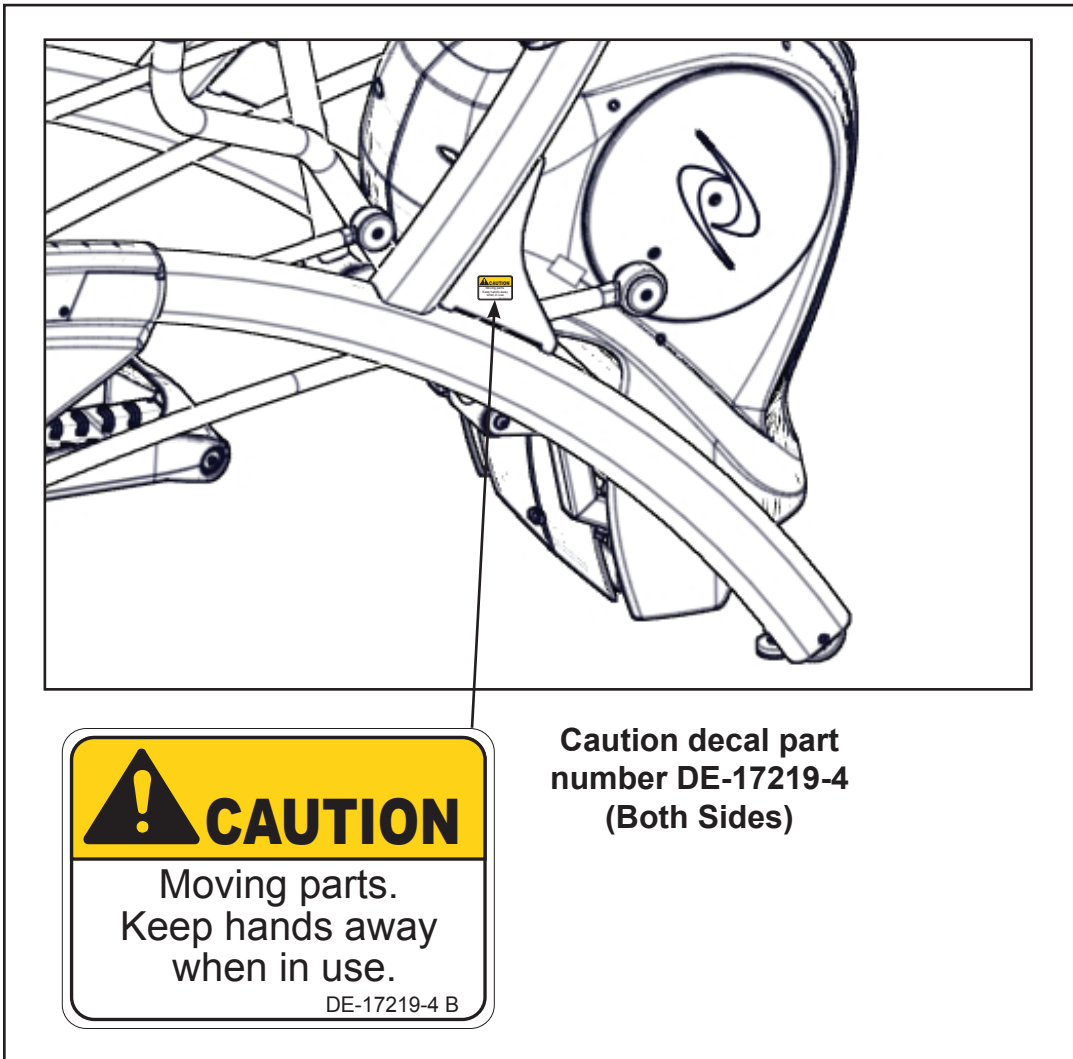

Caution decal part number DE-17219-4 (Both Sides)

CSAFE Port

The CSAFE standard defines a communication protocol and low-voltage DC power source specific to the Fitness Equipment Industry. These RJ-45 phone jacks are provided for use ONLY within the CSAFE protocol. For more information on CSAFE standard, visit www.fitlinxx.com/csafa.

The CSAFE port inside the console, accessible through the back cover, is the only port that carries BOTH the CSAFE communication lines and the 9.0v DC CSAFE power supply. If attaching a CSAFE compliant device that requires power, this connection must be used. Power is present only when the unit is in use or when a power supply is attached.

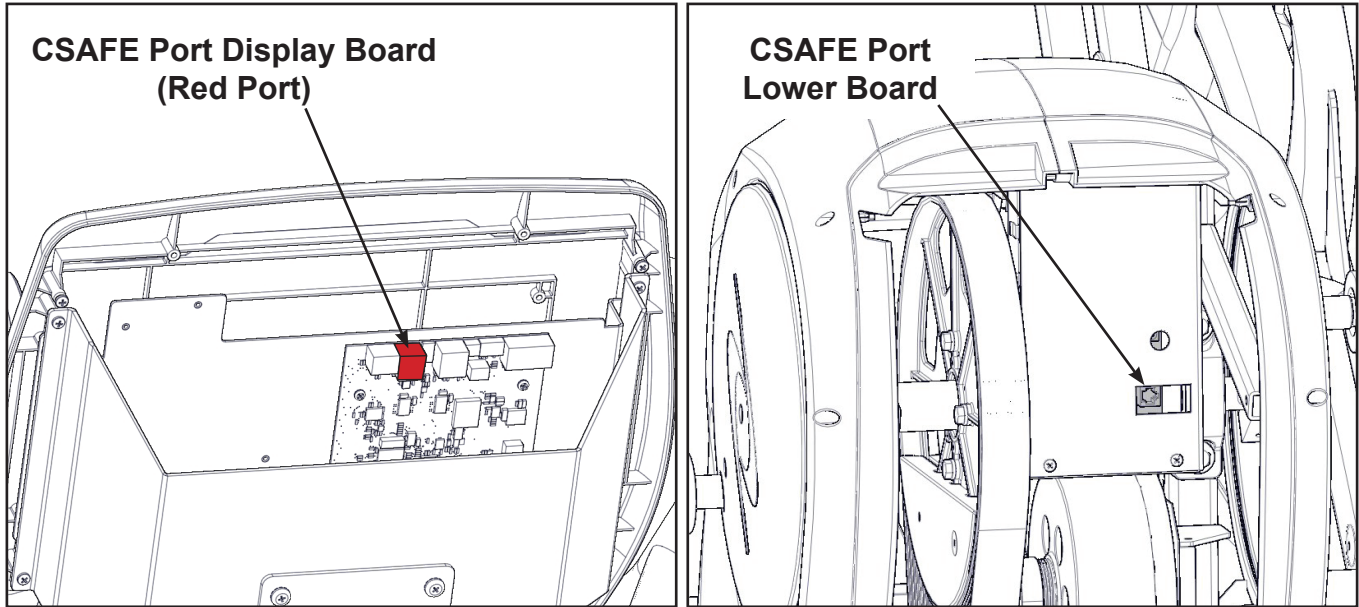

Assembly

Specifications - 625A

| | |
|---------------------|--|
| Classification | S (Studio) |
| Accuracy | A |
| Assembled Length | 75.75" (192 cm) |
| Assembled Width | 32" (81 cm) |
| Height: | 62.5" (159 cm) |
| Weight of Product | 404 lbs (183 kg) |
| Shipping Weight | 429 lbs (195 kg) |
| Incline Levels | 0-20 |
| Resistance Levels | 0-100 |
| Stride Length | 24" (61 cm) fixed length. |
| Programs | Quick Start plus Manual, and nine Factory Programs. |
| Console Features | Upper console: LED or EPEM (Embedded Personal Entertainment Monitor). Displays Cal/Hr, Distance, Strides per Minute, Calories, Watts, METs and BPM. Lower console: Two numeric displays for incline, resistance and level. Accessory trays and water bottle holder |
| Heart Rate Features | Built-in wireless heart rate receiver (transmitter not included) and contact heart rate monitoring. |
| Frame Colors | Standard: White Texture, Black Texture, Metaltone Gold, Black Chrome, Platinum Sparkle. Custom: Unlimited colors available. |
| Resistance Range | 0-900 watt. |
| Maximum User Weight | 400 lbs. (181 kg). |
| Power Rating | Self powered or 100 - 240 VAC~, 50/60 Hz, 1.8A, 1-phase. |
| Options | AC Power Adapter |

The dimensions stated in the installation instructions are the recommended minimum dimensions as set forth by the manufacturer. The actual area for access and passage shall be the responsibility of the facility and should take into account any required local codes or regulations.

625A Top View

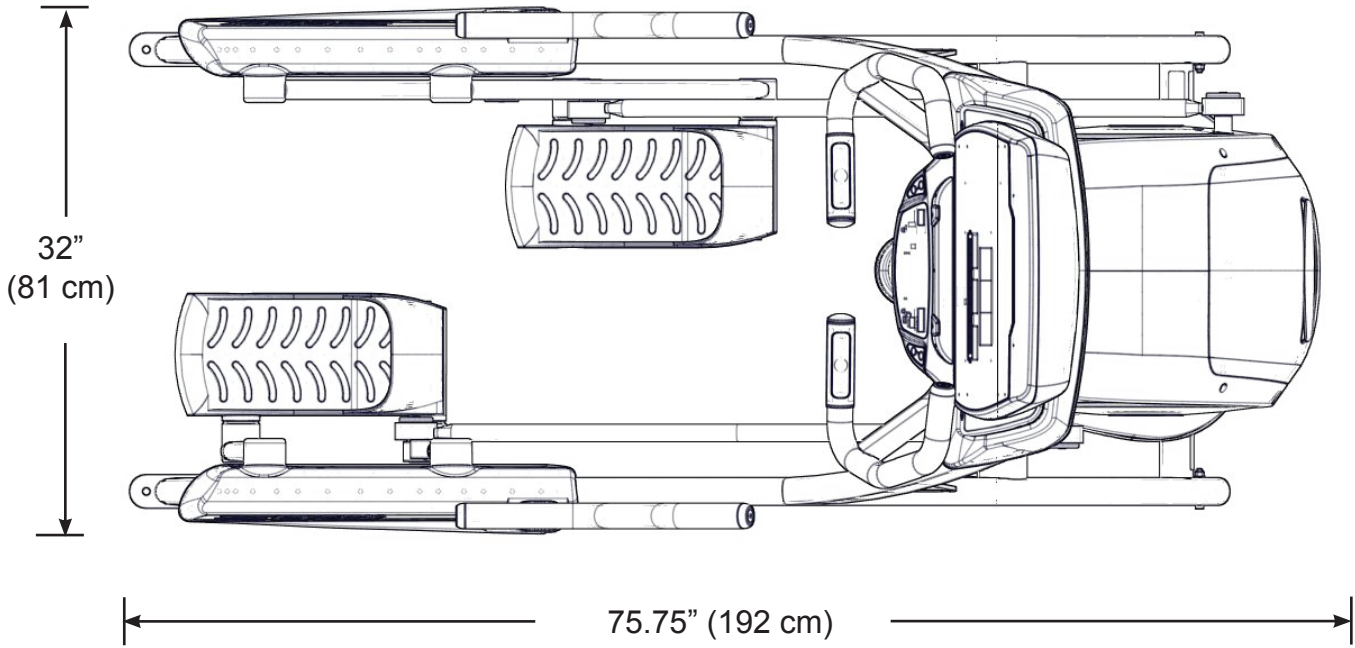

Specifications - 625AT

| | |
|---------------------|---|
| Classification | S (Studio) |
| Accuracy | A |
| Assembled Length | 75.75" (192 cm) |
| Assembled Width | 32" (81 cm) |
| Height: | 62.5"(159 cm) |
| Weight of Product | 412 lbs. (187 kg.) |
| Shipping Weight | 437 lbs. (198 kg.) |
| Incline Levels | 0-20 |
| Resistance Levels | 0-100 |
| Stride Length | 24" (61 cm) fixed length. |
| Programs | Quick Start plus Manual, and nine Factory Programs. |
| Console Features | Upper console: LED or EPEM (Embedded Personal Entertainment Monitor). Displays Cal/Hr, Distance, Strides per Minute, Calories, Watts, METs and BPM. Lower console: Two numeric displays for incline, resistance and level. Accessory trays and water bottle holder. |
| Heart Rate Features | Built-in wireless heart rate receiver (transmitter not included) and contact heart rate monitoring. |
| Frame Colors | Standard: White Texture, Black Texture, Metaltone Gold, Black Chrome, Platinum Sparkle. Custom: Unlimited colors available. |
| Resistance Range | 0-900 watt. |
| Maximum User Weight | 400 lbs. (181 kg). |
| Power Rating | Self powered or 100 - 240 VAC~, 50/60 Hz, 1.8A, 1-phase. |
| Options | AC Power Adapter |

The dimensions stated in the installation instructions are the recommended minimum dimensions as set forth by the manufacturer. The actual area for access and passage shall be the responsibility of the facility and should take into account any required local codes or regulations.

625AT Top View

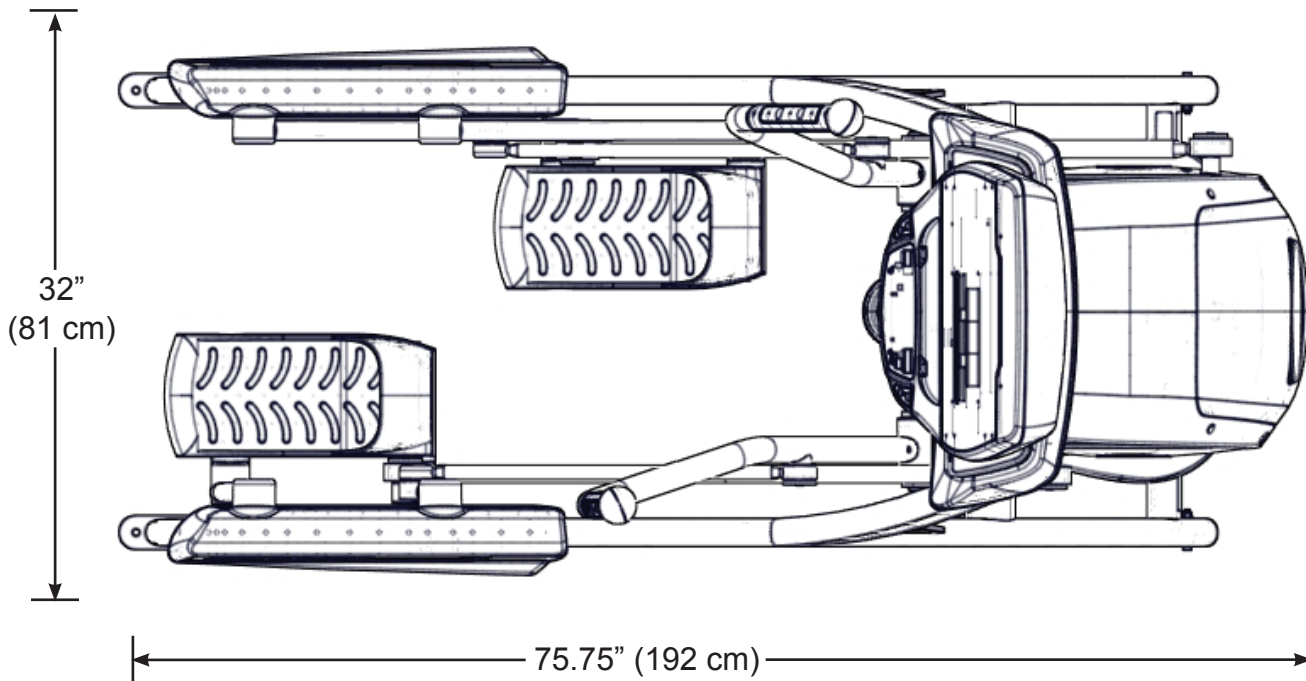

Environment and Storage

Humidity and Static Electricity

The unit is designed to function normally in an environment with a relative humidity range of 30% to 75%. The unit can be shipped and stored in a relative humidity range of 10% to 90%.

Dry air may cause static electricity. During workout, user may experience a shock due to build-up of static electricity on the body and the discharge path of the unit. If static electricity is experienced, increase humidity to a comfortable level through the use of a humidifier.

Do not install, use, or store the unit in an area of high humidity, such as in the vicinity of a steam room, sauna, indoor pool or outdoors. Exposure to extensive water vapor, chlorine and/or bromine could adversely affect the electronics as well as other parts of the unit.

Temperature

The unit is designed to function normally in an environment with an ambient temperature range of 50° F (10° C) to 104° F (40° C). The unit can be shipped and stored in an environment with an ambient temperature range of 32° F (0° C) to 140° F (60° C).

Warning and Caution Decals

 Read and understand all warnings and cautions listed in Safety Section before assembling unit.

 **CAUTION:** *Serious injury or damage to machine can occur. To avoid injury the following precautions must be observed. A minimum of two people are required to lift, move and assemble this unit. Always use proper lifting methods when moving heavy items.*

Ensure all electrical requirements are met as indicated in the specifications in the Safety Section and as listed in this chapter.

Choosing and Preparing Site

Before assembling the unit, verify chosen site meets the following criteria:

- Area is well lit and well ventilated.
- Surface is structurally sound and properly leveled.

Place a 3/4" (1.9 cm) thick wood base under unit to protect carpeting.

Area allows for ample access and passage clearance around unit or for emergency dismount. Minimum clearance is 19.7 inches (0.5 meters) on at least one side of unit and also behind unit. Minimum clearance fo 12" (30 cm) between units for proper wireless heart rate signal operation.

Electrical Power Requirements

AC Power Adapter is optional.

- Verify unit is connected to an outlet having the same configuration as the plug.
- Verify connection is a grounded circuit.
- Do not use a ground-plug adapter to adapt the 3-prong power cord to a non-grounded electrical outlet.
- Use Cybex supplied optional AC power kit only. Consult an electrician with any questions.
- Ensure outlets used by this product meet all local and federal building codes.

625A Assembly

The words “left” and “right” denote the user’s orientation.

 Read and understand all instructions thoroughly before assembling this unit. Check all items carefully. If there is damage, see the Customer Service section of this manual for proper procedure to return, replace, or reorder parts.

Verify correct package.

1. Read box label to verify the model number and voltage (optional) match what was ordered.
2. Lift and remove cardboard sleeve surrounding unit.
3. Verify paint color matches what was ordered.

Tools Required

- Phillips screwdriver
- Stubby Phillips screwdriver
- 7/32” Allen wrench (supplied)
- 9/16” Open end wrench (2)

Two people will be required for this procedure. It is the responsibility of the facility owner/owner of the equipment to ensure that there is appropriate clearance around each machine to allow for safe use and passage.

Unpack and verify contents of carton

See content listing and diagram below for carton contents. See **Customer Service** for contact information if any parts are missing.

| Item | Quantity | Part Number | Description |
|------|----------|-------------|-------------------------------|
| 1 | 1 | Varies | Base with covers attached |
| 2 | 1 | Varies | Console assembly |
| 3 | 2 | 12090-322 | Foot pad |
| 4 | 1 | NA | Handle, Right |
| 5 | 1 | NA | Handle, Left |
| 6 | 1 | 770A-316 | Base, Accessory tray |
| 7 | 1 | 770A-317 | Cover, Top, Accessory tray |
| 8 | 1 | 770A-318 | Cover, Bottom, Accessory tray |
| 9 | 1 | 770A-322 | Cover, Rear, Top, Right |
| 10 | 1 | 770A-323 | Cover, Rear, Outer, Right |
| 11 | 1 | 770A-324 | Cover, Rear, Inner, Right |
| 12 | 1 | 770A-319 | Cover, Rear, Top, Left |
| 13 | 1 | 770A-321 | Cover, Rear, Inner, Left |
| 14 | 1 | 770A-320 | Cover, Rear, Outer, Left |
| 15 | 1 | 770A-341 | Collar, Outer, Right |
| 16 | 1 | 770A-340 | Collar, Inner, Right |

| Item | Quantity | Part Number | Description |
|------|----------|-------------|-------------------------------|
| 17 | 1 | 770A-335 | Collar, Inner, Left |
| 18 | 1 | 770A-334 | Collar, Outer, Left |
| 19 | 1 | NA | Hardware pack |
| 20 | 1 | 5625-4 | Owner's Manual |
| 21 | 1 | 625A-328 | Assembly poster |
| 22 | 1 | 625A-330 | Commercial Arc warranty sheet |
| 23 | 1 | 625A-331 | Consumer Arc warranty sheet |
| 24 | 1 | 770A-310 | Bracket, Lower, Display mount |

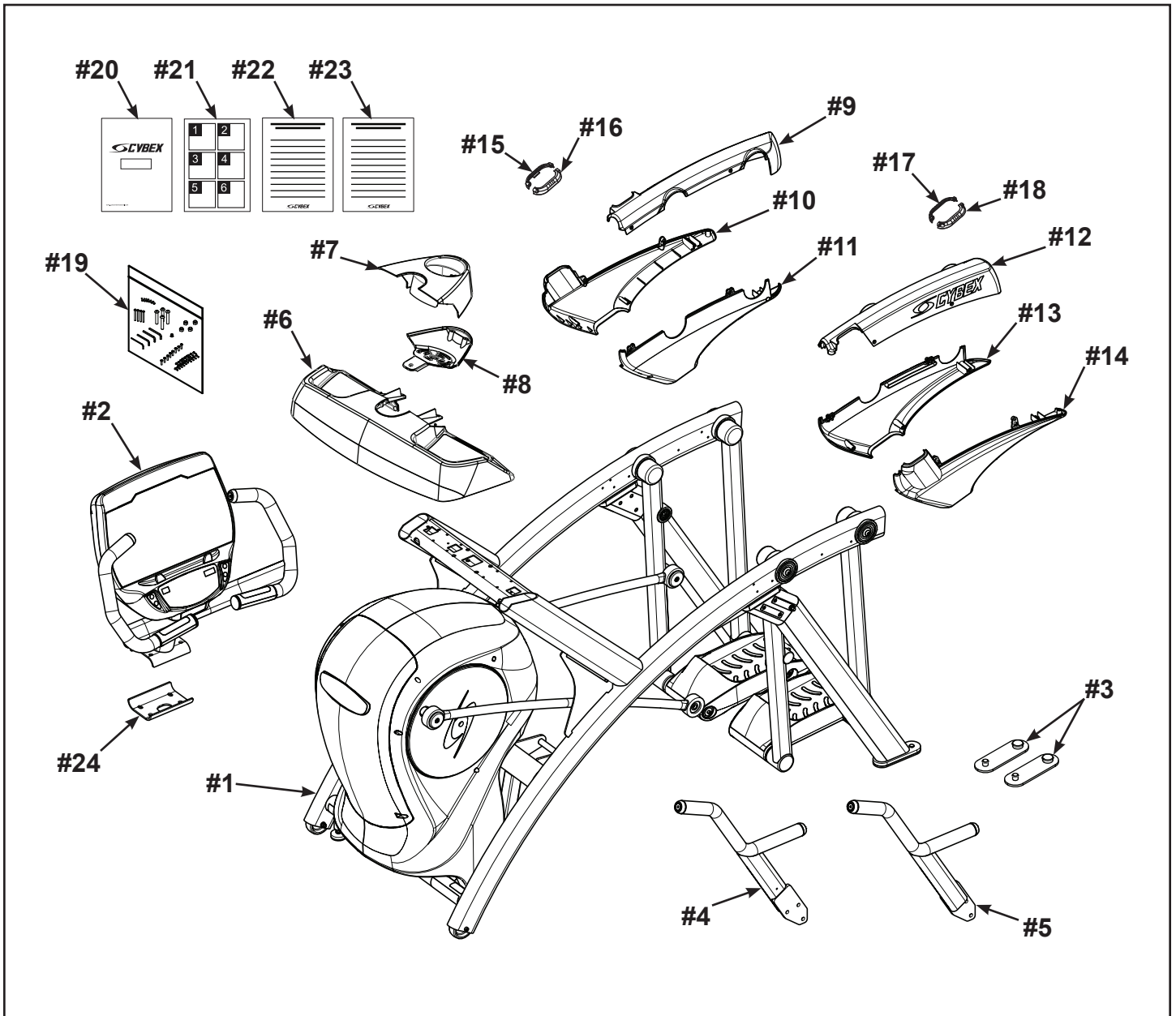

Verify contents of hardware pack

See hardware pack listings and hardware pack contents. See **Customer Service** for contact information if any parts are missing.

| Item | Quantity | Part Number | Description |
|------|----------|-------------|--|
| 25 | 1 | BK030204 | 7/32" Allen Wrench |
| 26 | 4 | HC700430 | BHSCS .375-16 x 2.50" |
| 27 | 1 | HF540200 | Grommet, Nylon |
| 28 | 4 | HN704901 | Locknut, .375-16 Nylon |
| 29 | 4 | HT592526 | Tap Sc 10-12 x 2.00 Pn Hd Phil |
| 30 | 6 | HT532512 | Screw, Pan Head Phillips, #6 x .50" |
| 31 | 19 | HT552512 | Screw, Pan Head Phillips, 8-16 x .50" |
| 32 | 8 | HT572515 | Screw, Pan Head Phillips, 10-24 x .75" |

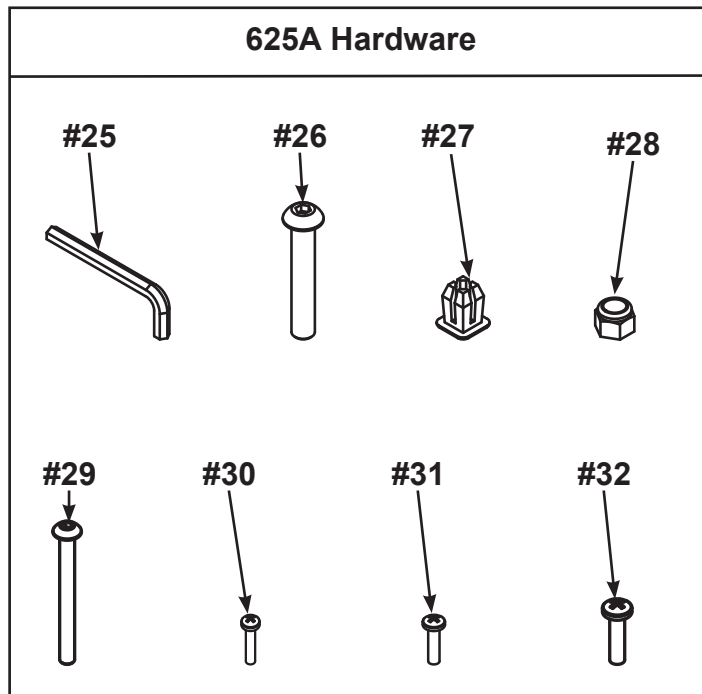

Lift and move unit

1. Remove large bolts and shipping supports. Keep package material on linkage arms at this time. This will protect the paint from scratching during assembly.
2. Grasp each rear support leg firmly and lift with one person on each side.
3. Lift the lower rear support legs using proper lifting methods so the front transport wheels are able to roll on floor.
4. Move unit to intended location.
5. Lower rear support legs.

Attach 625A console assembly

1. Place the console into position on the frame. Do not pinch cables while lowering the console.

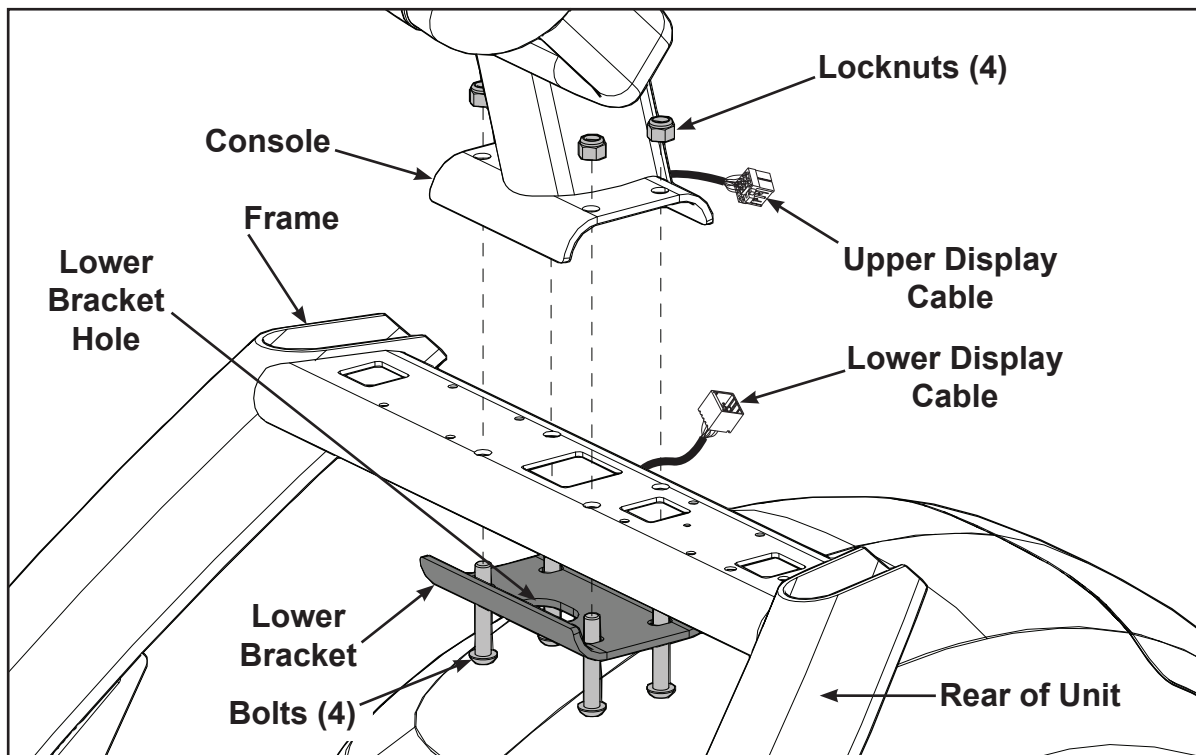

2. Insert (from underneath) the lower bracket and four bolts into the frame and console. Position lower bracket with lower bracket hole towards the rear of unit.
3. Thread the four locknuts onto the bolts by hand.
4. Tighten the four bolts and locknuts with a 7/32" Allen wrench and a 9/16" open-end wrench.
5. Plug the upper display cable into the lower display cable.

Install accessory tray base

1. Place the accessory tray base in position on the frame.

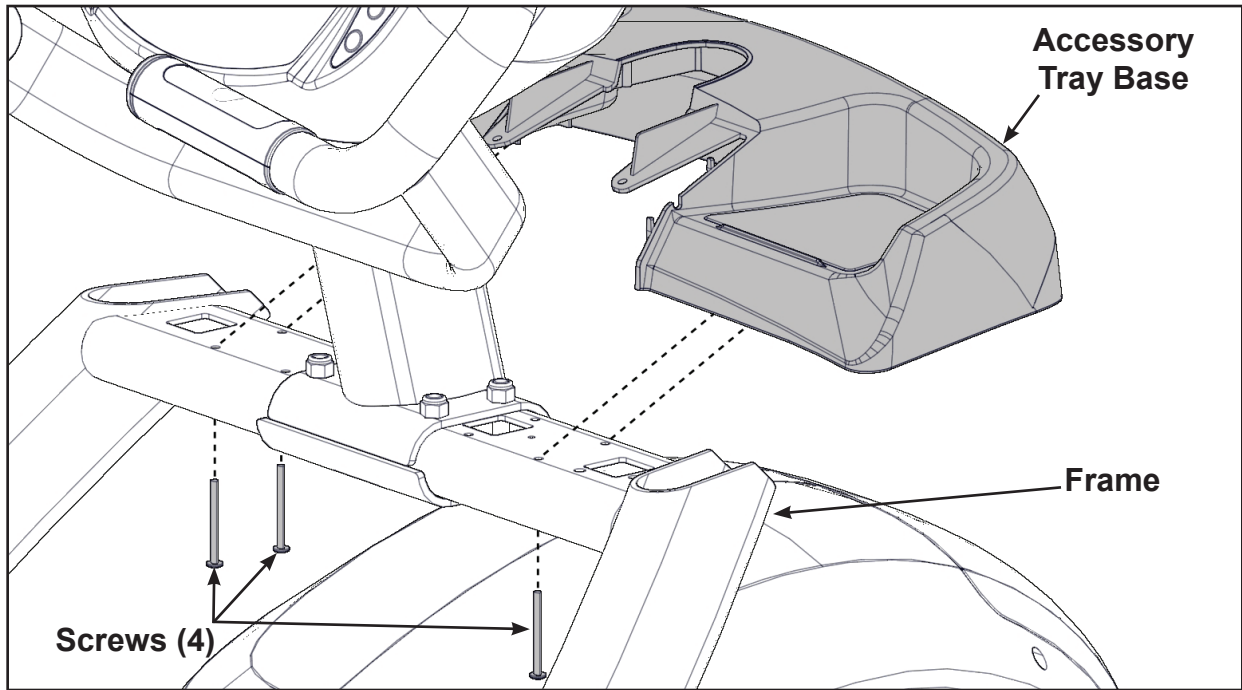

2. Install the four screws using a stubby Phillips screwdriver.

Install accessory tray top

1. Place the accessory tray top in position on the accessory tray base.

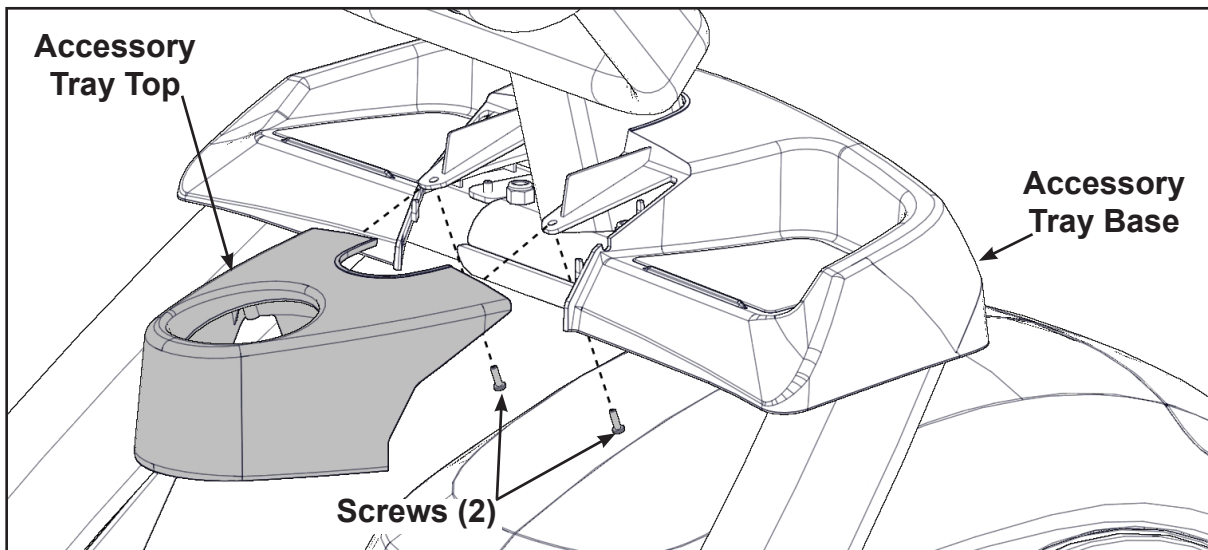

2. Install the two screws using a stubby Phillips screwdriver.

Install accessory tray bottom

1. Install the nylon grommet into the square hole in the frame.

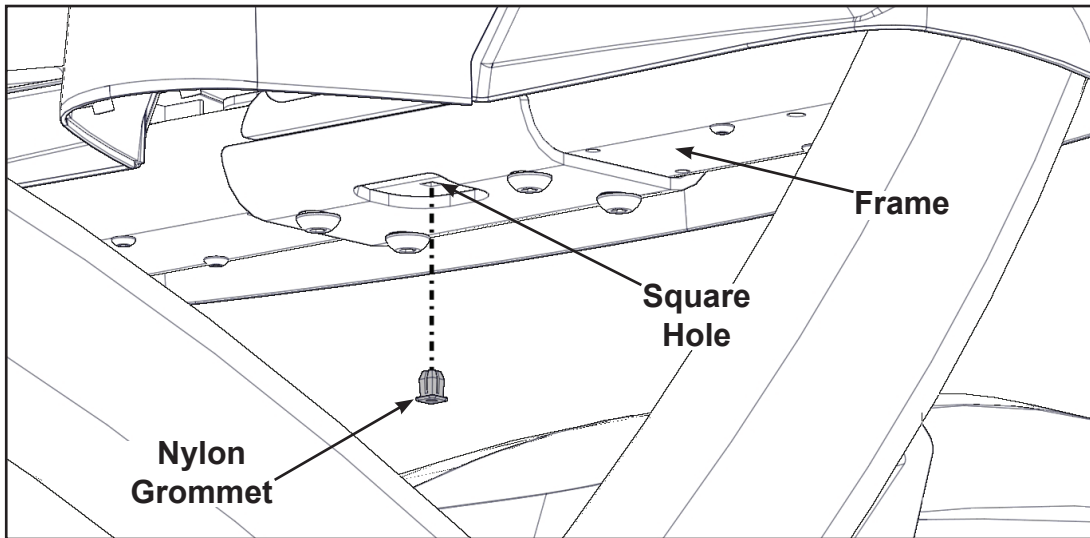

2. Install the accessory tray bottom to the accessory tray base with three screws using a Phillips screwdriver.

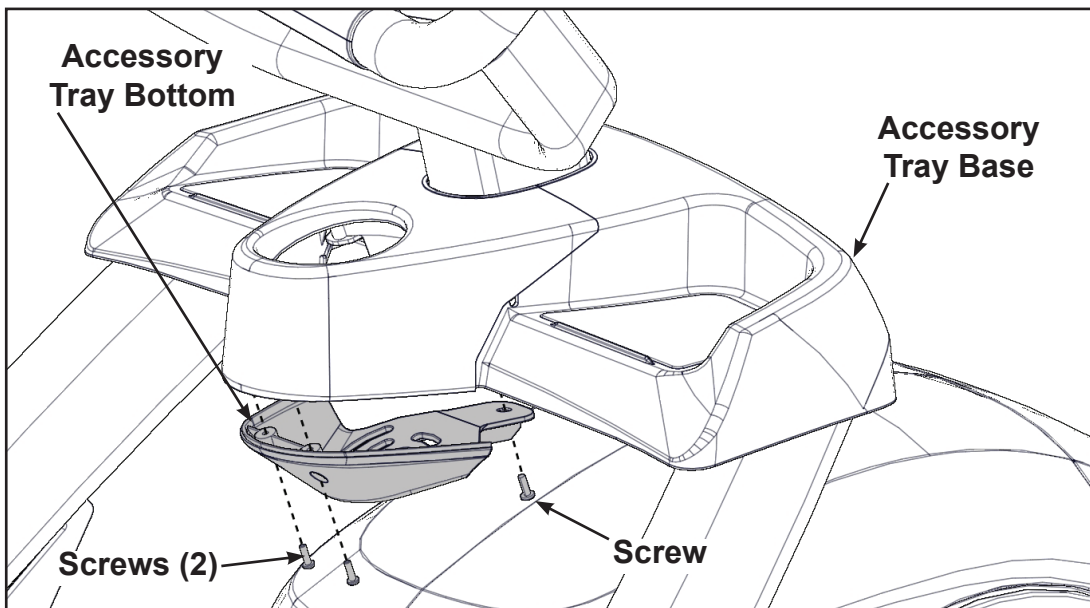

Install handrails

1. Remove three bolts and locknuts from the left support leg using two 9/16" open end wrenches. Keep the two spacers in place.

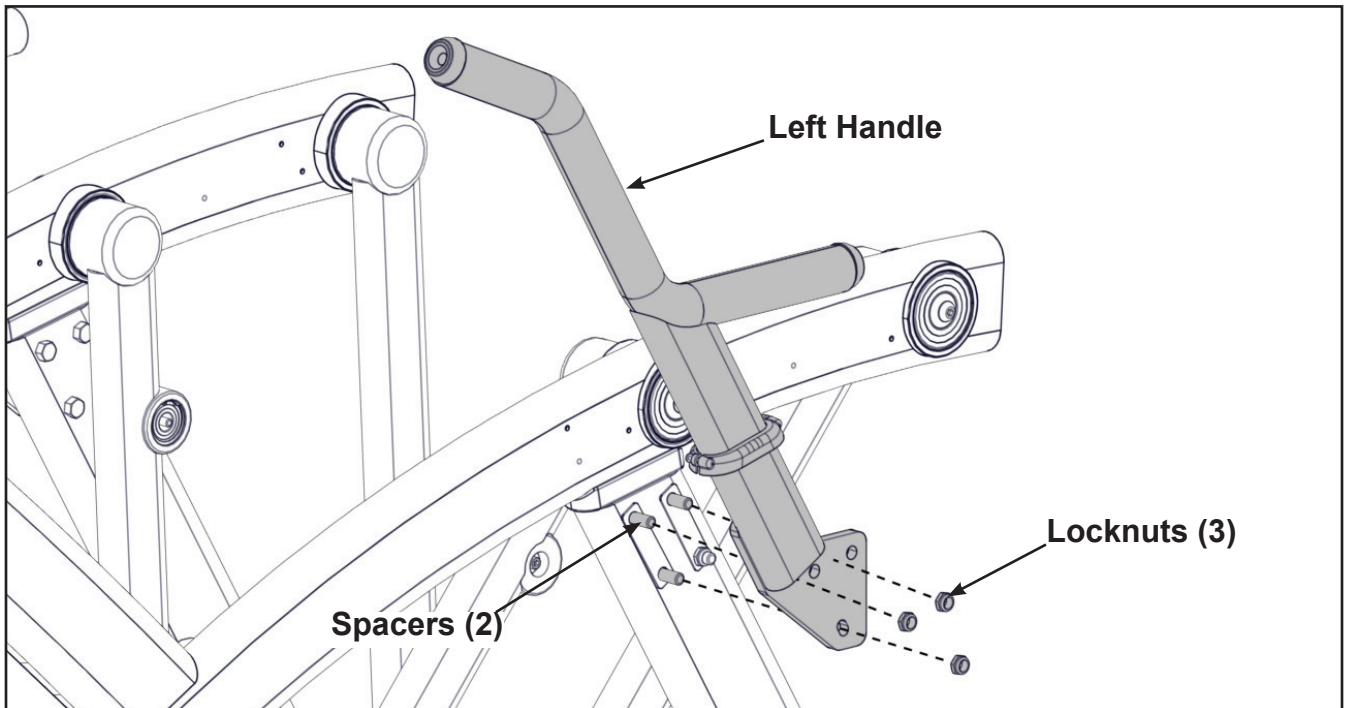

2. Install the left handle, three bolts and three locknuts using two 9/16" open end wrenches.
3. Install the left outer rear cover with two screws using a Phillips screwdriver.

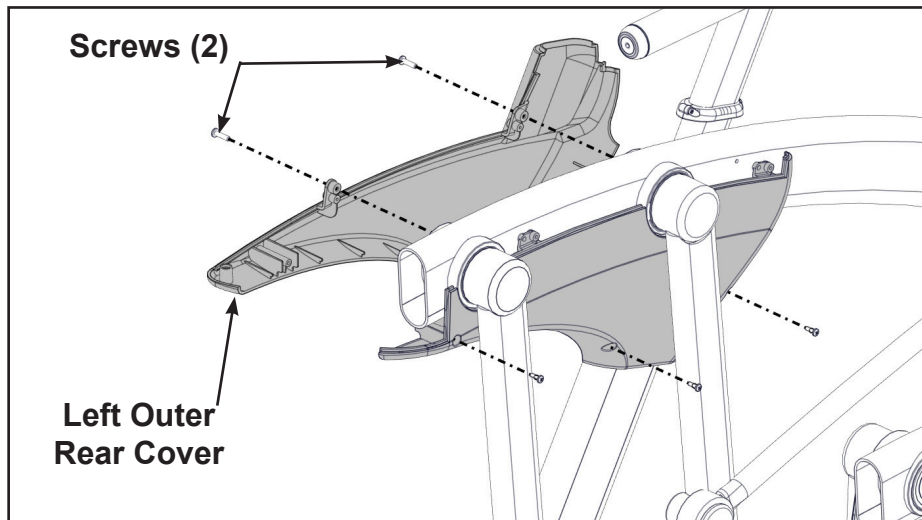

4. Install the left inner rear cover with five screws using a Phillips screwdriver.

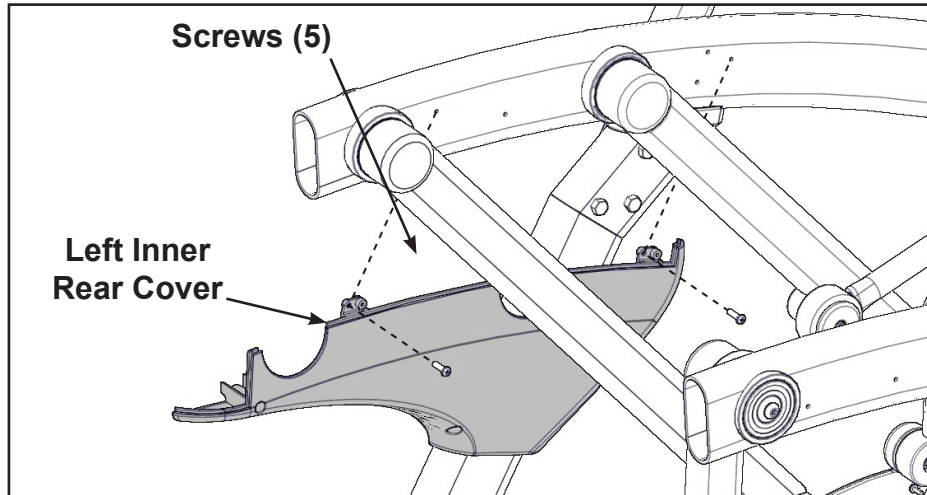

5. Install the left top rear cover with five screws using a Phillips screwdriver.

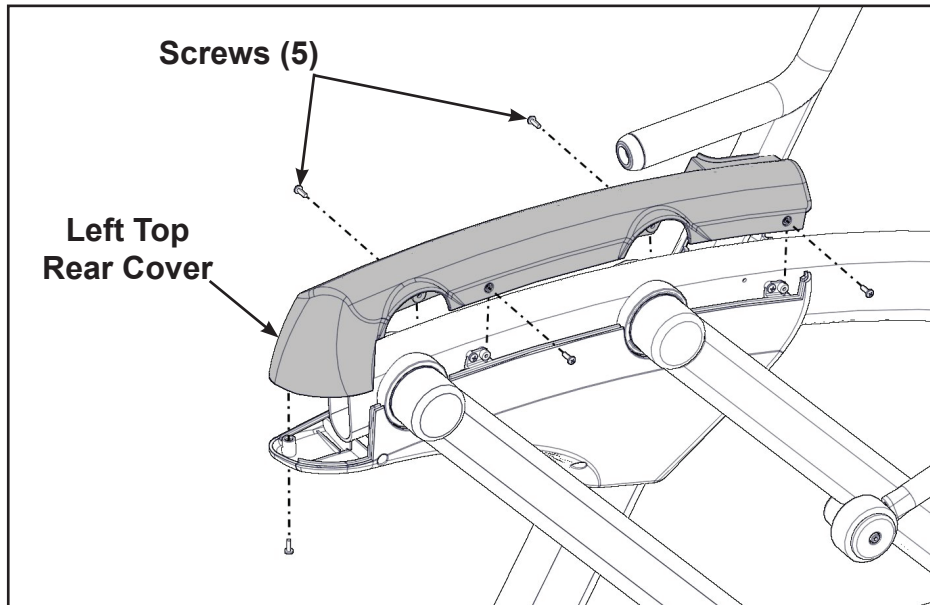

6. Install the left inner and outer collars with two screws using a Phillips screwdriver. Collars are marked with an "L" on the inside and have a left and right side.

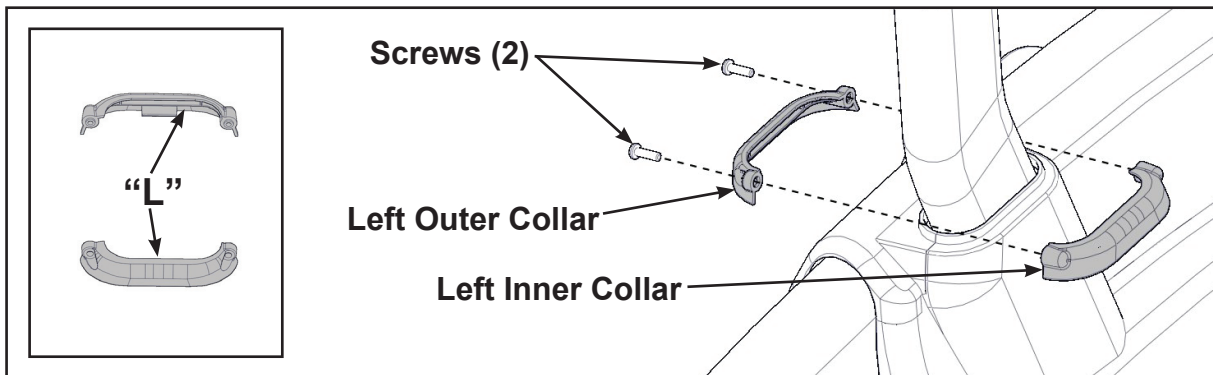

7. Remove three bolts and locknuts from the right support leg using two 9/16" open end wrenches. Keep the two spacers in place.

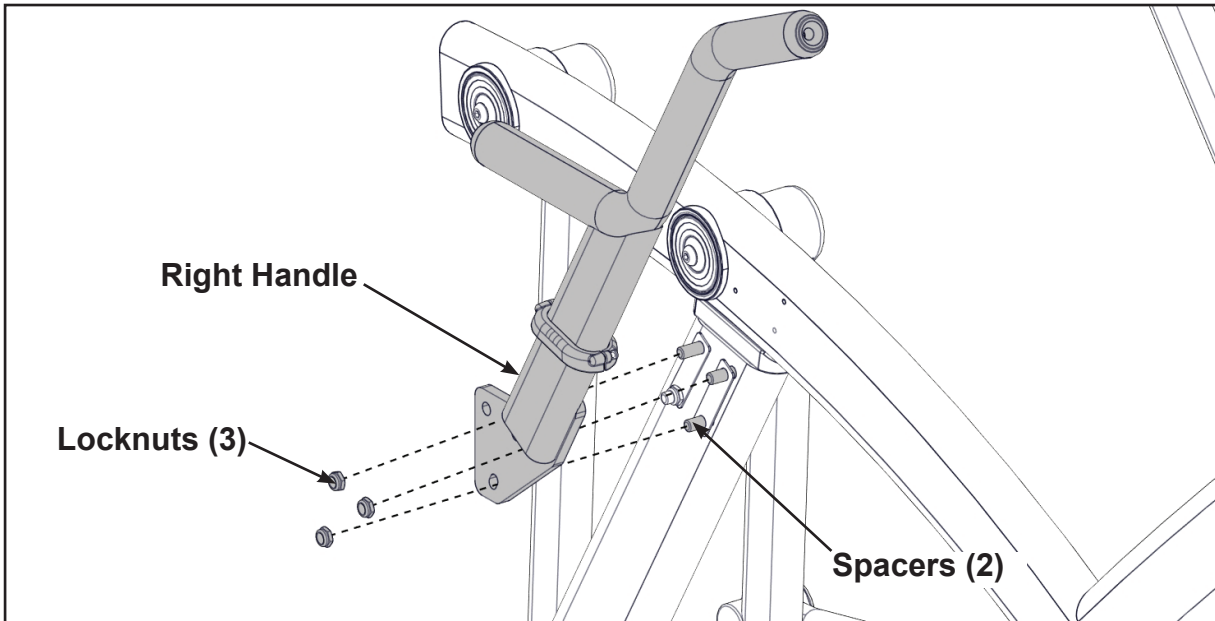

8. Install the right handle, three bolts and three locknuts using two 9/16" open end wrenches.
9. Install the right outer rear cover with two screws using a Phillips screwdriver.

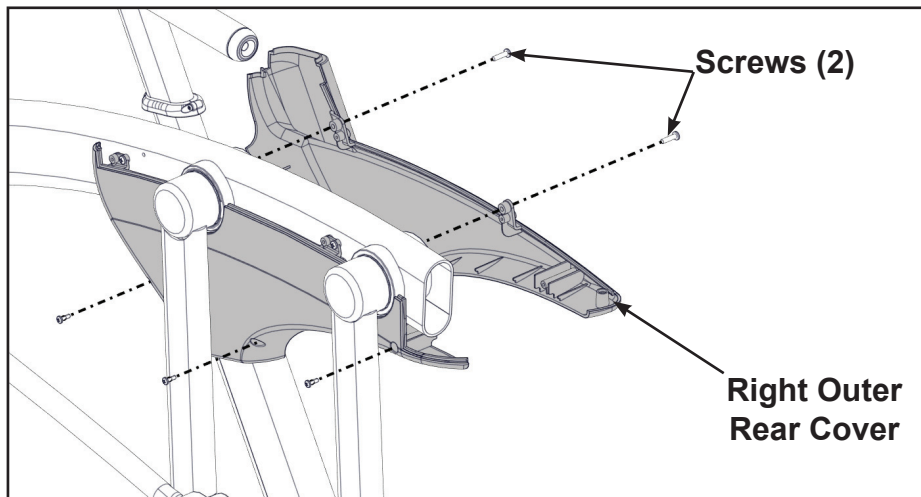

10. Install the right inner rear cover with five screws using a Phillips screwdriver.

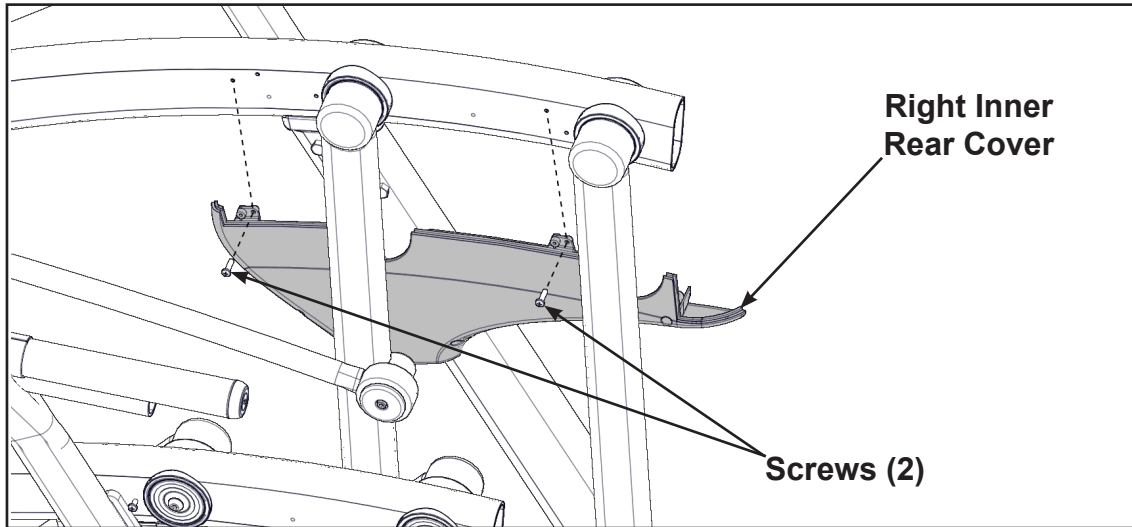

11. Install the right top rear cover with five screws using a Phillips screwdriver.

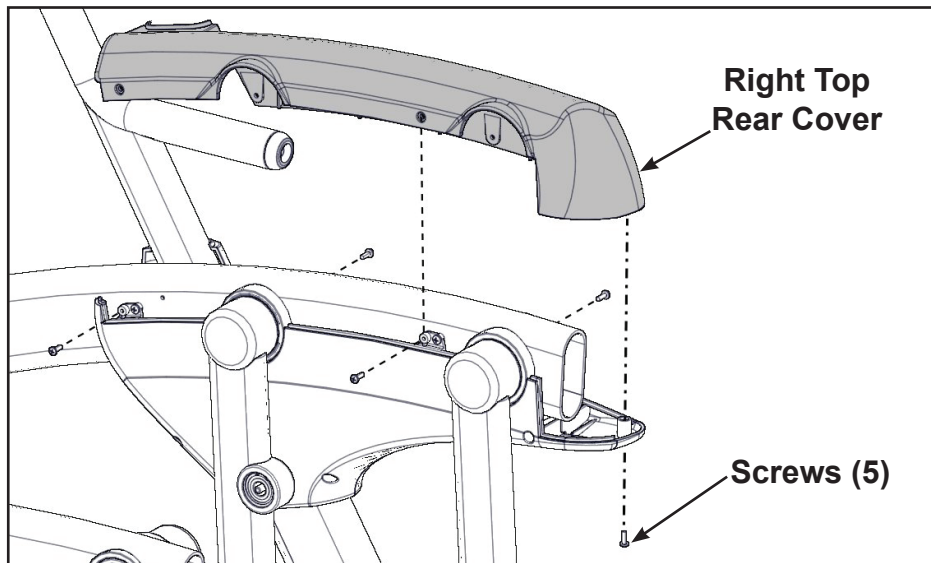

12. Install the right inner and outer collars with two screws using a Phillips screwdriver. Collars are marked with an "R" on the inside and have a left and right side.

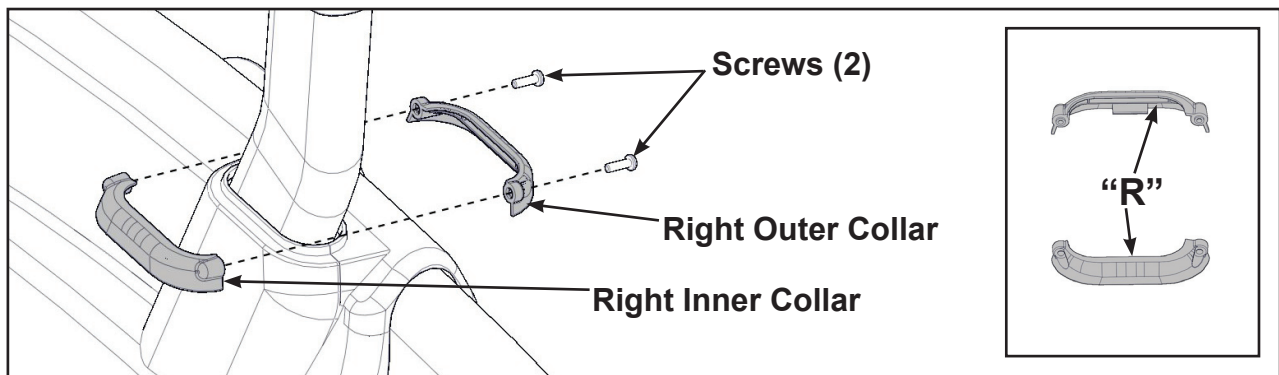

Attach foot pads

Have one person lift the unit while a second person places a foot pad under each of the two back feet.

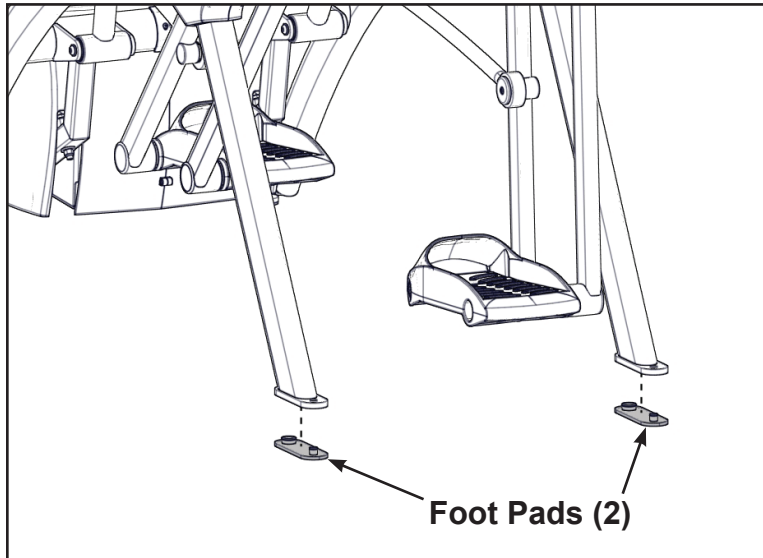

Level unit

Confirm unit is on a level surface. If not, use a 9/16" open-end wrench to adjust the leveling feet up or down.

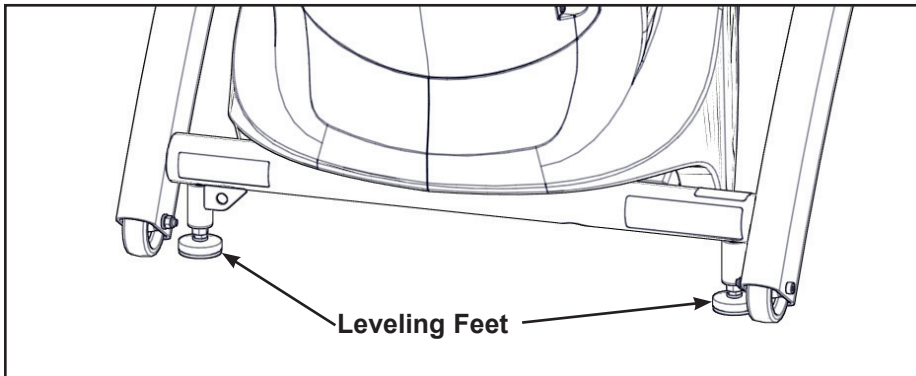

Visually inspect unit

1. Carefully remove any package material from arms and rest of unit.
2. Carefully examine the unit to ensure assembly is correct and complete.

625AT Assembly

The words “left” and “right” denote the user’s orientation.

 Read and understand all instructions thoroughly before assembling this unit. Check all items carefully. If there is damage, see the Customer Service section of this manual for proper procedure to return, replace, or reorder parts.

Verify correct package

1. Read box label to verify the model number and voltage (optional) match what was ordered.
2. Lift and remove cardboard sleeve surrounding unit.
3. Verify paint color matches what was ordered.

Tools Required

- Phillips screwdriver
- Stubby Phillips screwdriver
- 3/16” Allen wrench (supplied)
- 7/32” Allen wrench (2) (supplied)
- 9/16” Open end wrench (2)

Two people will be required for this procedure. It is the responsibility of the facility owner/owner of the equipment to ensure that there is appropriate clearance around each machine to allow for safe use and passage.

Unpack and verify contents of carton

See content listing and diagram below for carton contents. See **Customer Service** for contact information if any parts are missing.

| Item | Quantity | Part Number | Description |
|------|----------|-------------|-------------------------------|
| 1 | 1 | Varies | Base with covers attached |
| 2 | 1 | Varies | Console assembly |
| 3 | 2 | 12090-322 | Foot pad |
| 4 | 1 | 770A-316 | Base, Accessory tray |
| 5 | 1 | 770A-317 | Cover, Top, Accessory tray |
| 6 | 1 | 770A-318 | Cover, Bottom, Accessory tray |
| 7 | 1 | 625A-312 | Cover, Rear, Top, Right |
| 8 | 1 | 625A-313 | Cover, Rear, Outer, Right |
| 9 | 1 | 770A-324 | Cover, Rear, Inner, Right |
| 10 | 1 | 625A-310 | Cover, Rear, Top, Left |
| 11 | 1 | 770A-321 | Cover, Rear, Inner, Left |
| 12 | 1 | 625A-311 | Cover, Rear, Outer, Left |
| 13 | 1 | NA | Hardware pack |
| 14 | 1 | 5625-4 | Owner's Manual |
| 15 | 1 | 625AT-300 | Assembly poster |

| Item | Quantity | Part Number | Description |
|------|----------|-------------|-------------------------------|
| 16 | 1 | 770A-415 | Commercial Arc warranty sheet |
| 17 | 1 | 770A-416 | Consumer Arc warranty sheet |

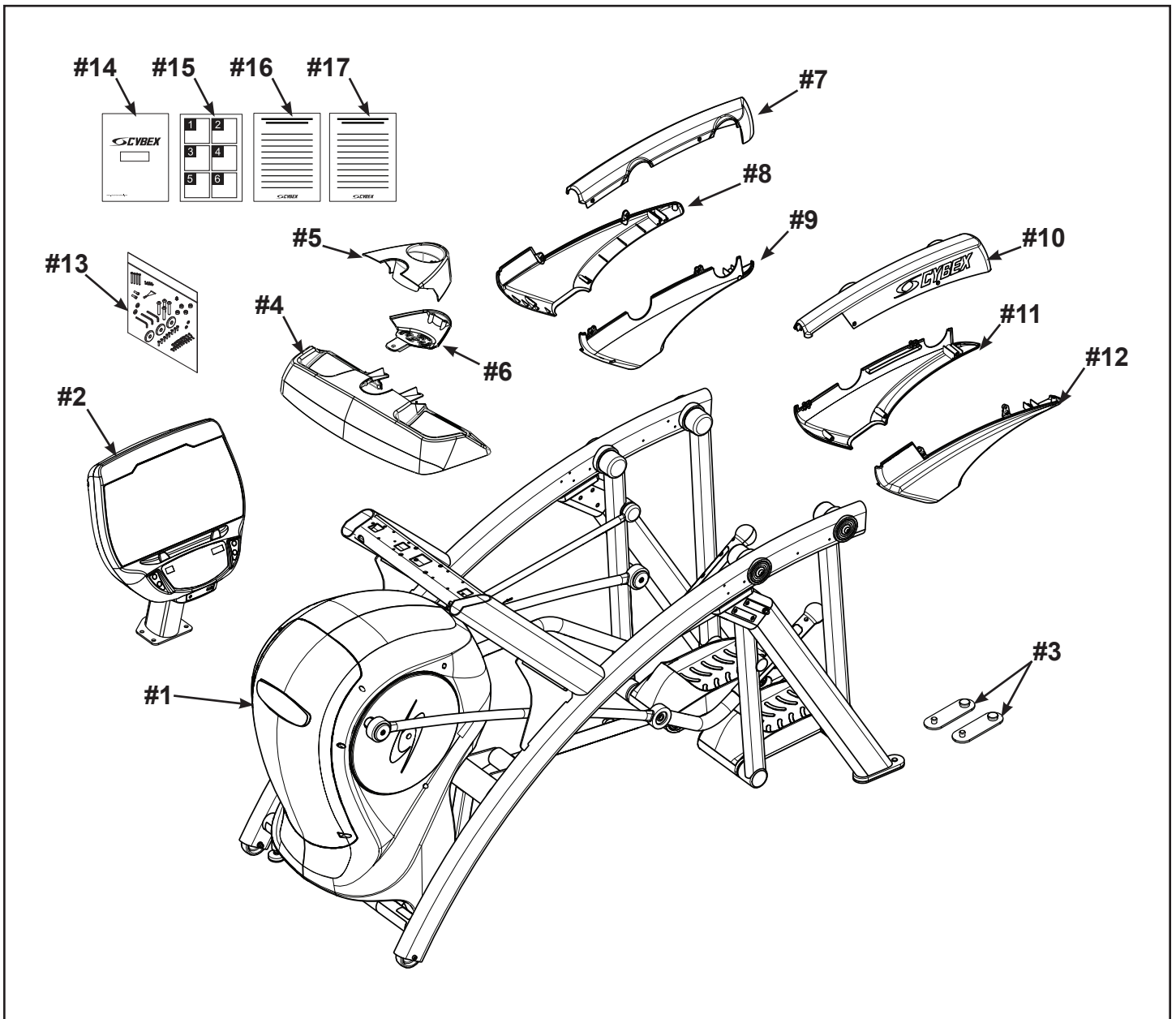

Verify contents of hardware pack

See hardware pack listings and hardware pack contents. See **Customer Service** for contact information if any parts are missing.

| Item | Quantity | Part Number | Description |
|------|----------|-------------|--|
| 18 | 2 | 600A-311 | Flange Spacer |
| 19 | 1 | BK030201 | 3/16" Allen Wrench |
| 20 | 2 | BK030204 | 7/32" Allen Wrench |
| 21 | 4 | HC700428 | BHSCS .375-16 x 2.25" |
| 22 | 1 | HF540200 | Grommet, Nylon |
| 23 | 4 | HN704901 | Locknut, .375-16 Nylon |
| 24 | 4 | HT592526 | Tap Sc 10-12 x 2.00 Pn Hd Phil |
| 25 | 2 | HS307601 | Washer, Flat .281 ID x .500 OD x .062" |
| 26 | 2 | HT532512 | Screw, Pan Head Phillips, #6 x .50" |
| 27 | 19 | HT552512 | Screw, Pan Head Phillips, 8-16 x .50" |
| 28 | 8 | HT572515 | Screw, Pan Head Phillips, 10-24 x .75" |
| 29 | 2 | HX622815 | SHCS .250-20 UNC-3A SS |
| 30 | 3 | PL-16535 | Linkage Rod Cap 2.00 OD (1 extra) |
| 31 | 1 | YA000201 | Loctite |

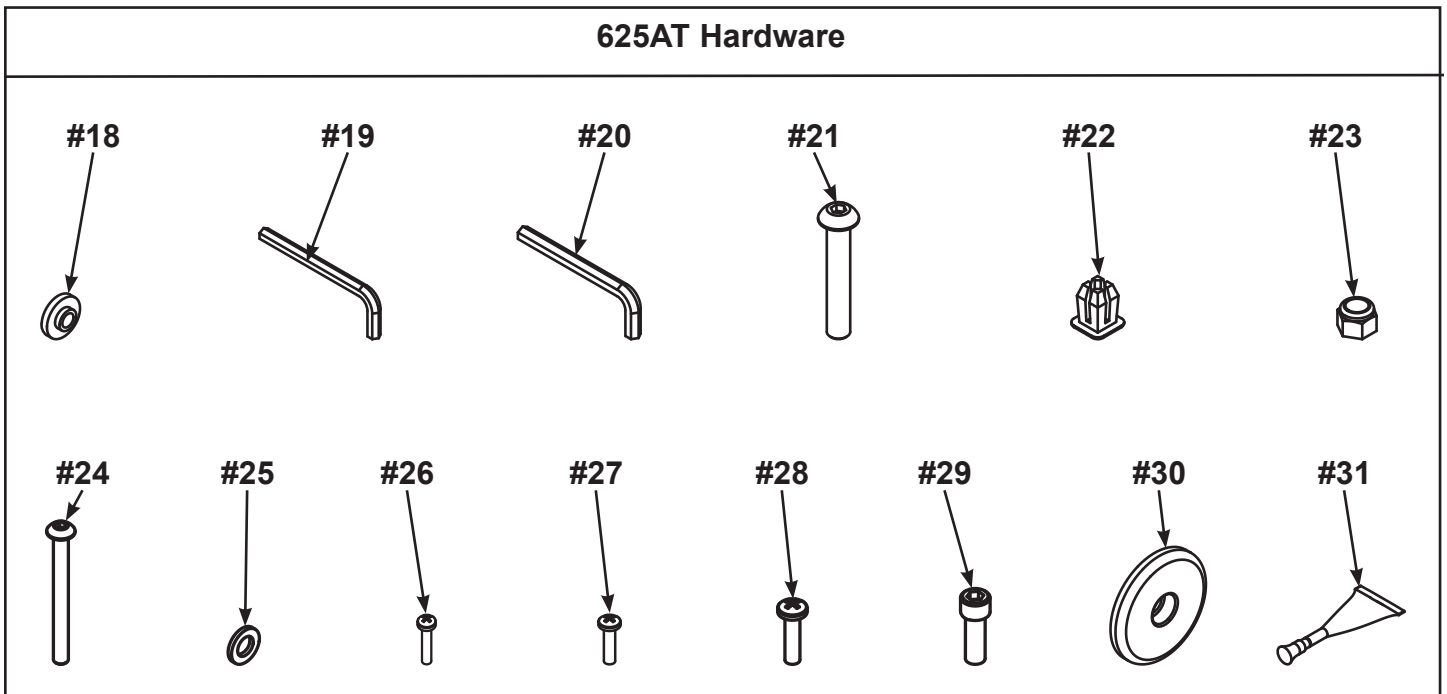

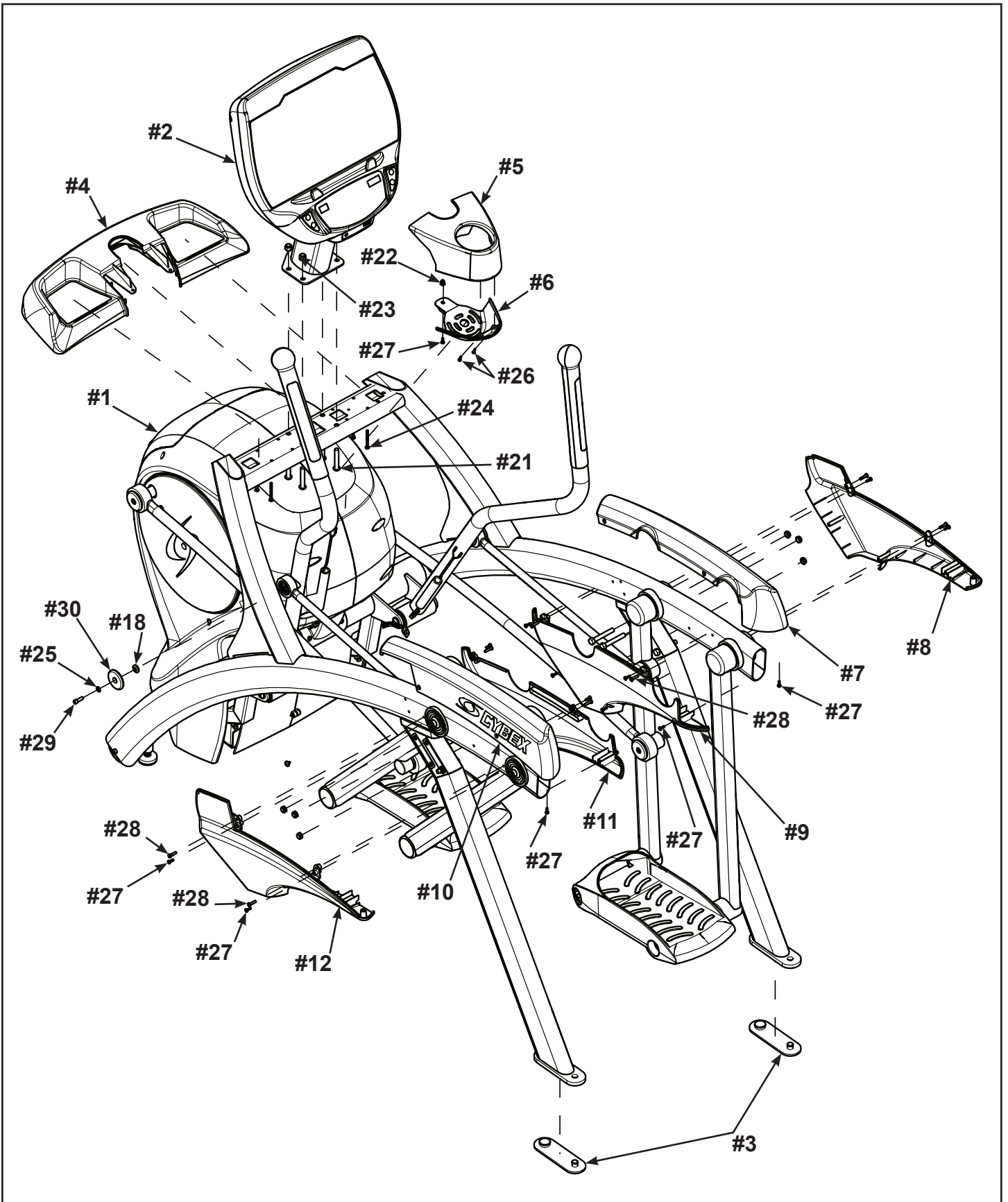

Lift and move unit

1. Remove large bolts and shipping supports. Keep package material on linkage arms at this time. This will protect the paint from scratching during assembly.
2. Grasp each rear support leg firmly and lift with one person on each side.
3. Lift the lower rear support legs using proper lifting methods so the front transport wheels are able to roll on floor.
4. Move unit to intended location.
5. Lower rear support legs.

Attach 625AT console assembly

1. Plug the upper heart rate cable into the lower heart rate cable.

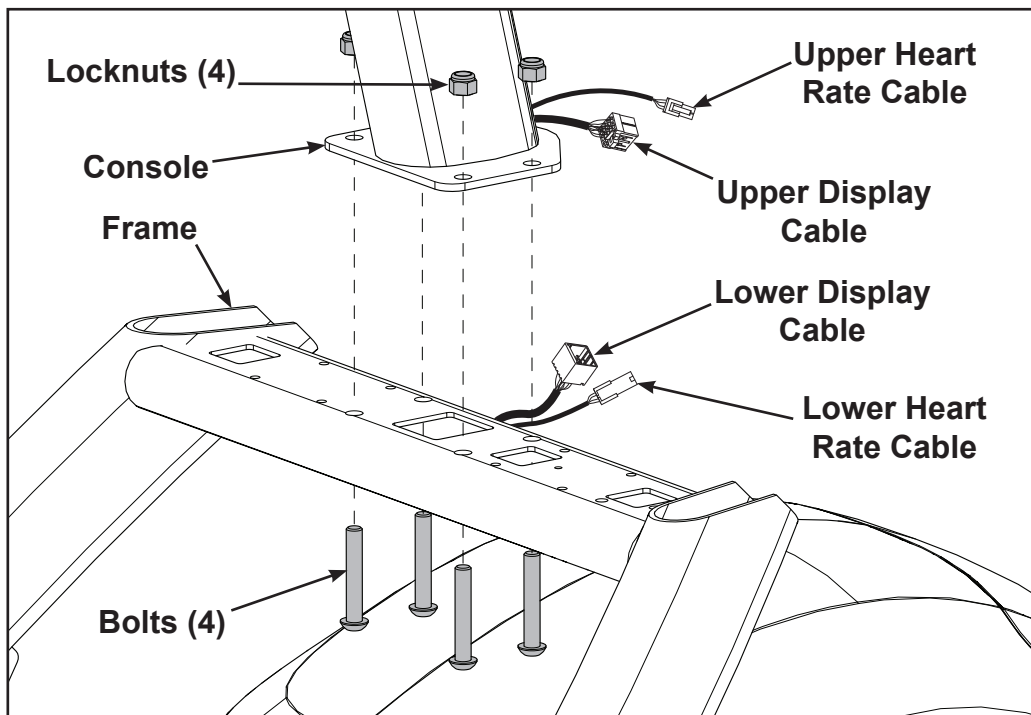

2. Place the console into position on the frame. Do not pinch cables while lowering the console.
3. Insert (from underneath) the four bolts into the frame and console.
4. Thread the four locknuts onto the bolts by hand.
5. Tighten the four bolts and locknuts with a 7/32" Allen wrench and a 9/16" open-end wrench.
6. Plug the upper display cable into the lower display cable.

Install accessory tray base

1. Place the accessory tray base in position on the frame.

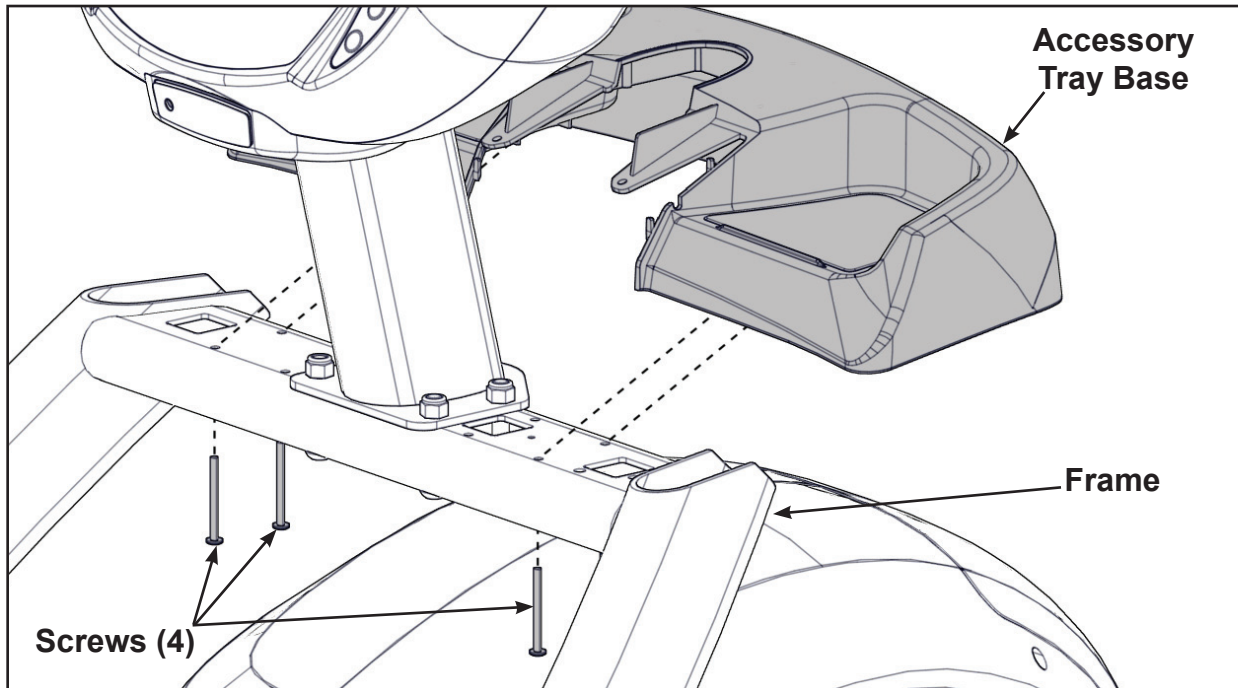

2. Install the four screws using a stubby Phillips screwdriver.

Install accessory tray top

1. Place the accessory tray top in position on the accessory tray base.

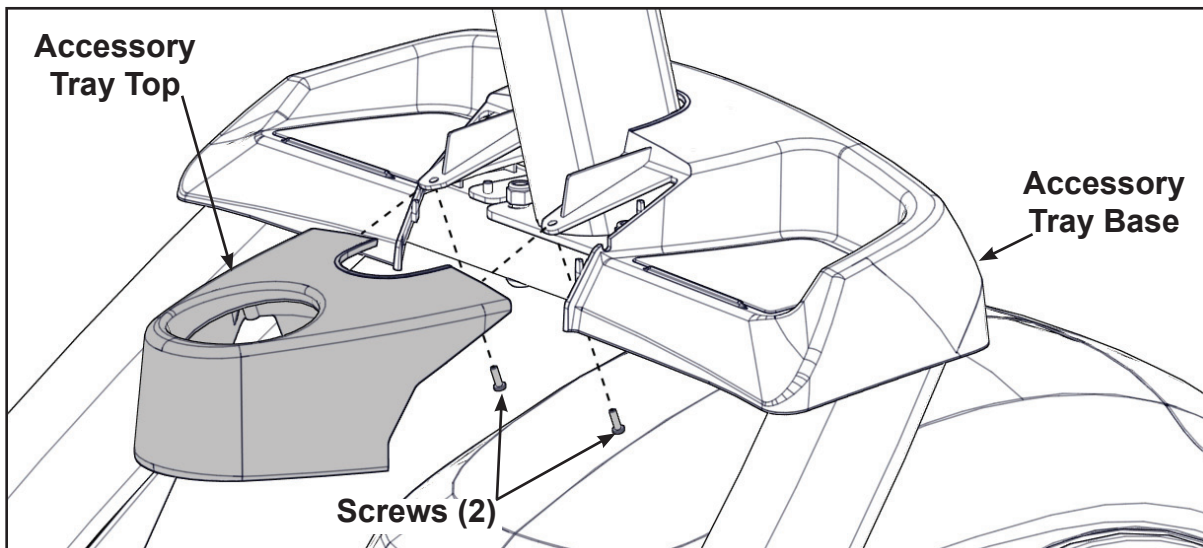

2. Install the two screws using a stubby Phillips screwdriver.

Install accessory tray bottom

1. Install the nylon grommet into the square hole in the frame.

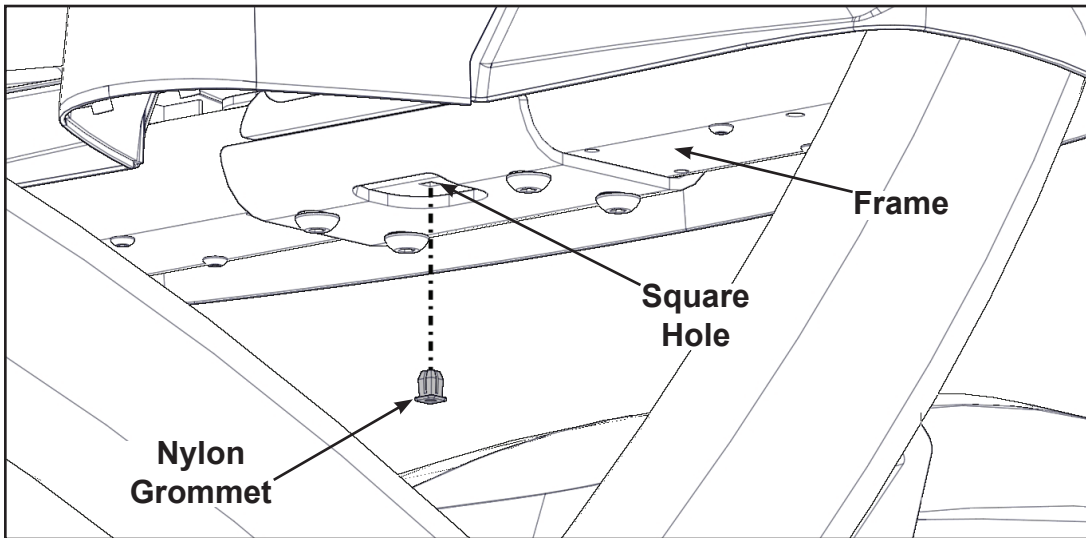

2. Install the accessory tray bottom to the accessory tray base with three screws using a Phillips screwdriver.

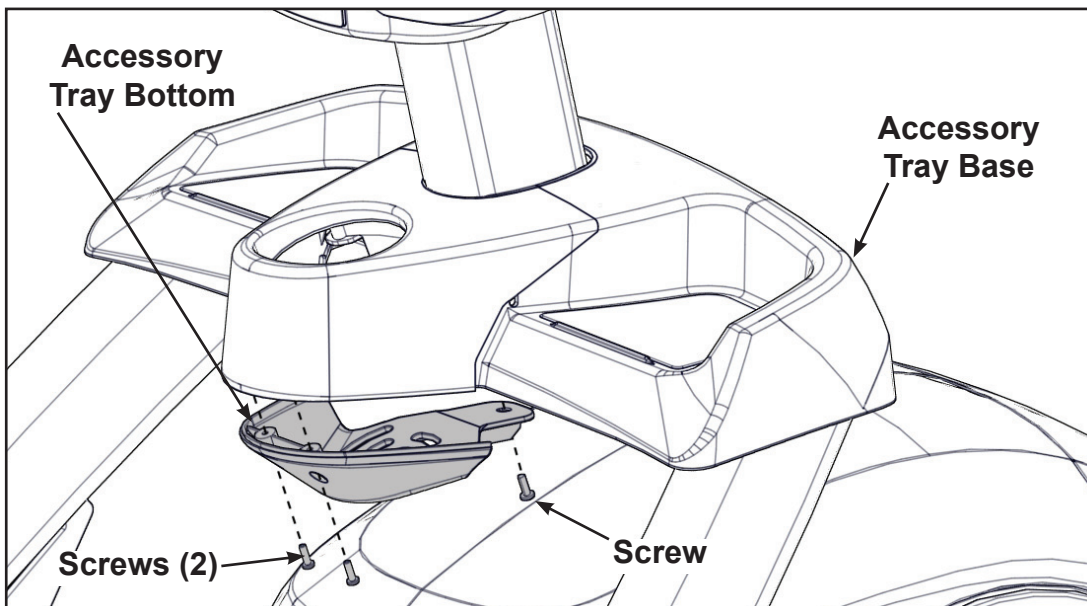

Remove left and right handle assembly

The left and right handle assemblies are shipped in rotated positions. The handle assemblies must be removed and rotated 180 degrees for proper setup and assembly.

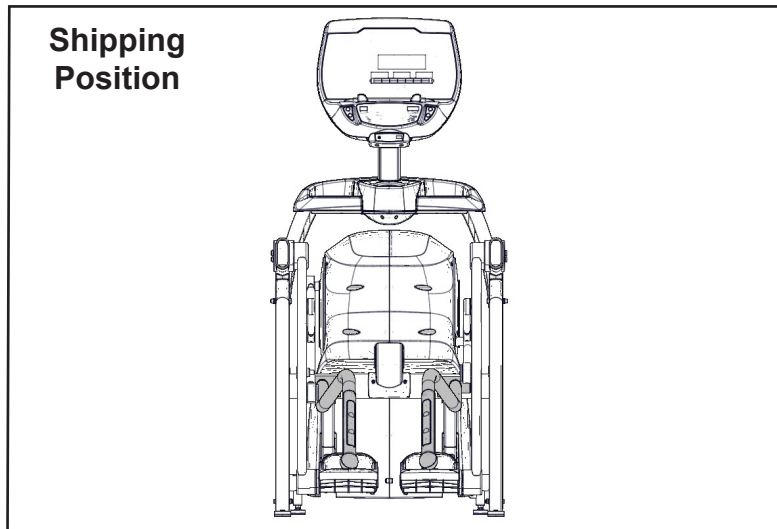

1. Remove a screw and washer from the left handle assembly using two 7/32" Allen wrenches.

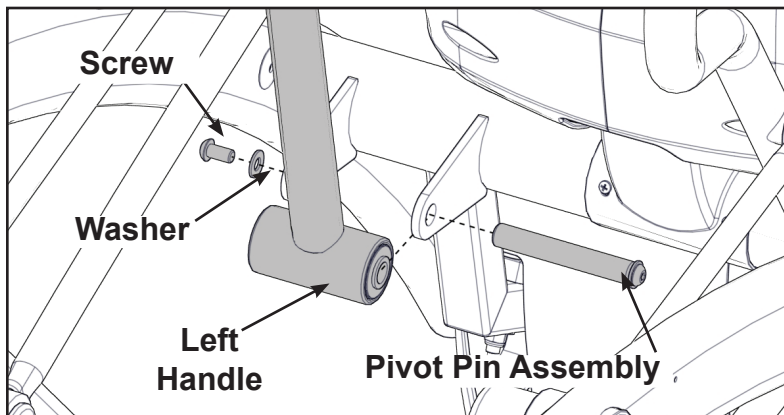

2. Slide pivot pin assembly out and remove left handle assembly.
3. Rotate left handle assembly 180 degrees.
4. Apply Loctite to threads inside the pivot pin and screw.
5. Place left handle assembly in position and slide pivot pin assembly back in place.
6. Install the screw and washer to the left handle assembly using two 7/32" Allen wrenches.

7. Remove a screw and washer from the right handle assembly using two 7/32" Allen wrenches.

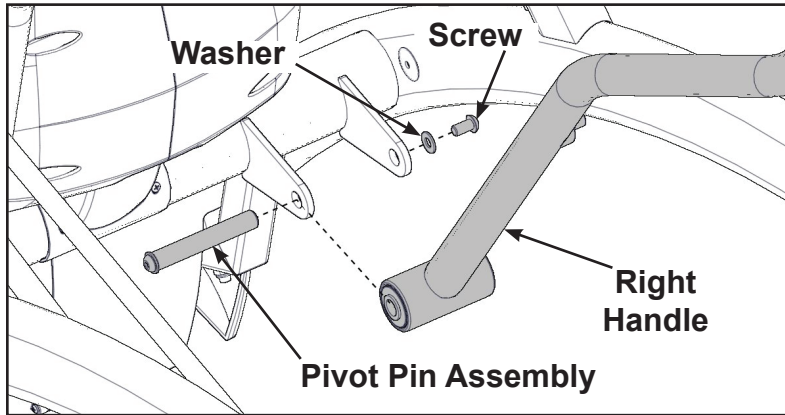

8. Slide pivot pin assembly out and remove right handle assembly.
9. Rotate right handle assembly 180 degrees.
10. Apply Loctite to threads inside the pivot pin and screw.
11. Place right handle assembly in position and slide pivot pin assembly back in place.
12. Install the screw and washer to the right handle assembly using two 7/32" Allen wrenches.

Install the left linkage rod

1. Pivot left handle assembly up and slide left linkage rod onto left arm.

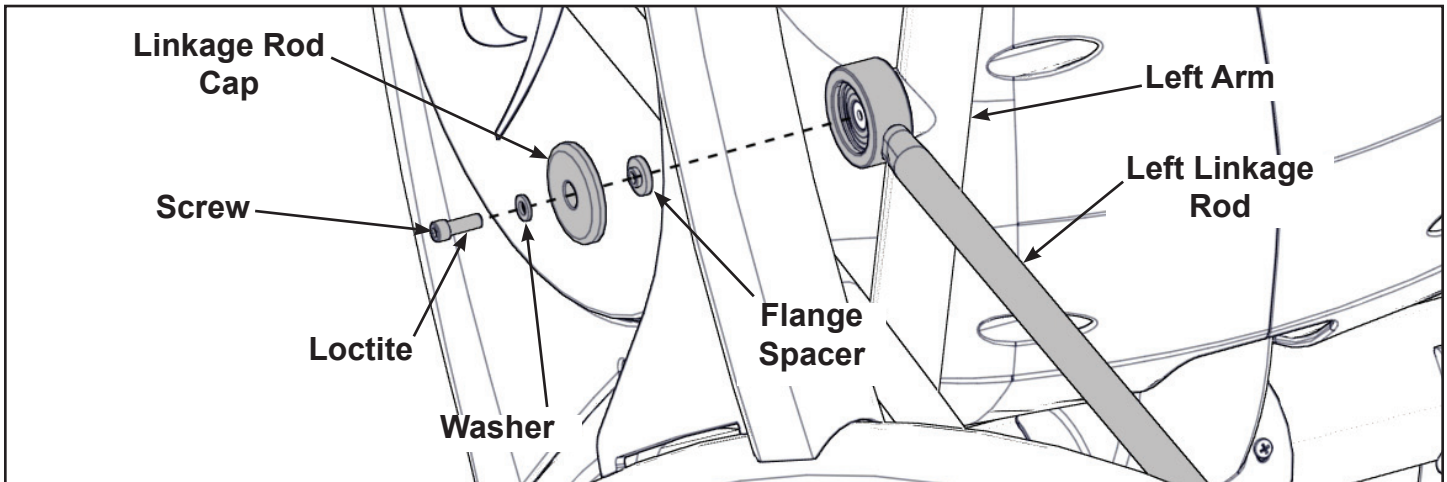

2. Place a drop of Loctite onto the screw.
3. Install the screw, washer, linkage rod cap, and flange spacer using a 3/16" Allen wrench.
4. Tighten screw to a minimum of 90 in/lbs.

Install right linkage rod

1. Pivot right handle assembly up and slide left linkage rod onto left arm.

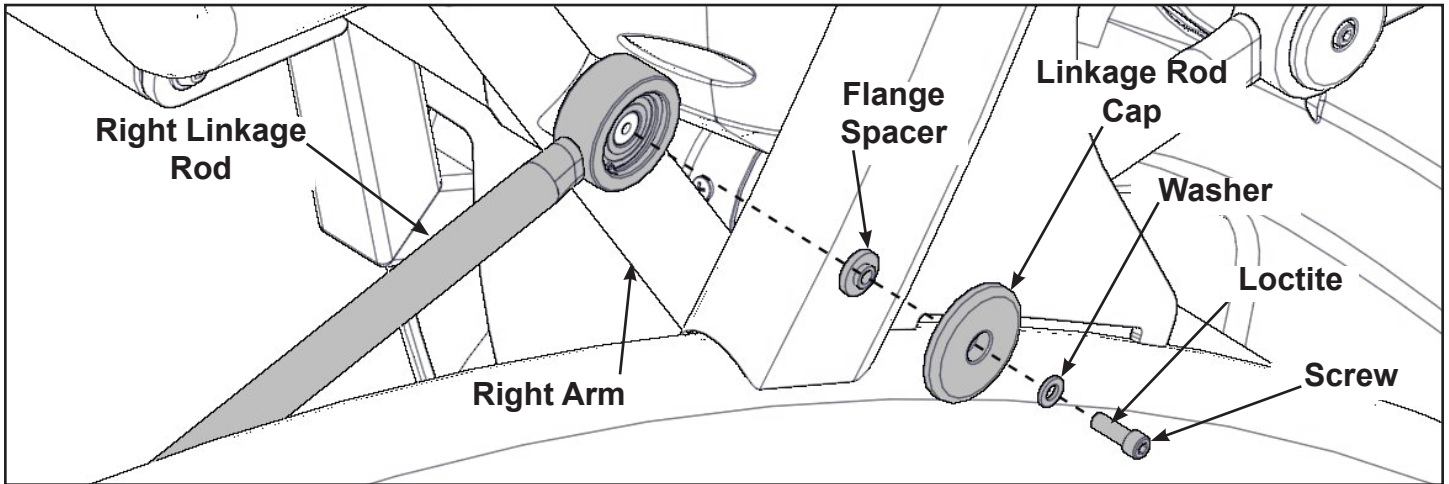

2. Place a drop of Loctite onto the screw.
3. Install the screw, washer, linkage rod cap, and flange spacer using a 3/16" Allen wrench.
4. Tighten screw to a minimum of 90 in/lbs.

Verify handle assemblies are now installed in the correct position.

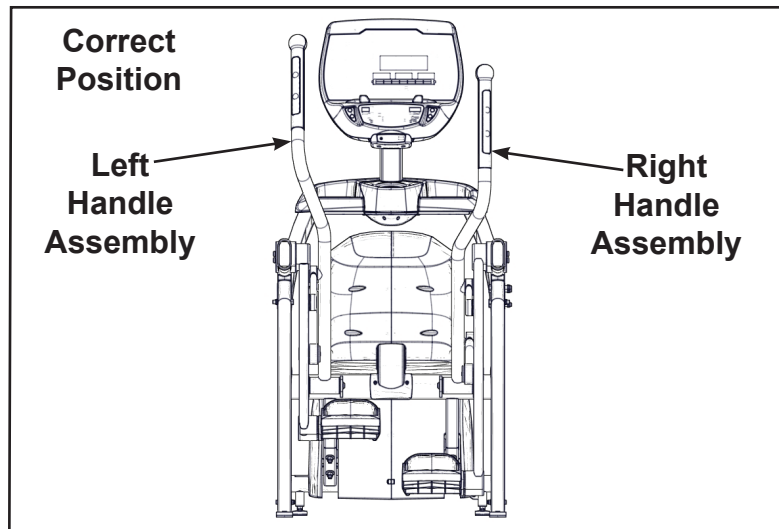

Connect contact heart rate cable

1. Plug right heart rate cable into main frame socket.

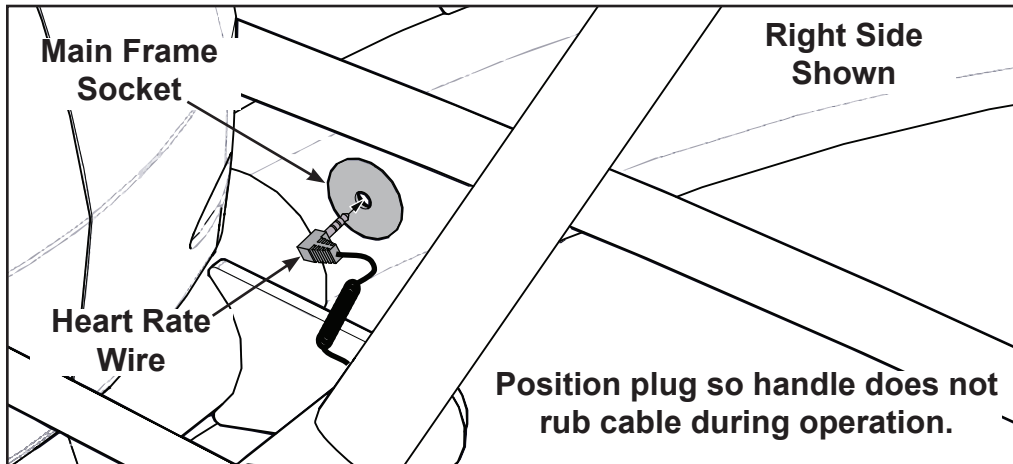

2. Plug left heart rate cable into main frame socket.

Verify heart rate cables do not rub on handle during operation.

Install rear covers.

1. Install the left outer rear cover with two screws using a Phillips screwdriver.

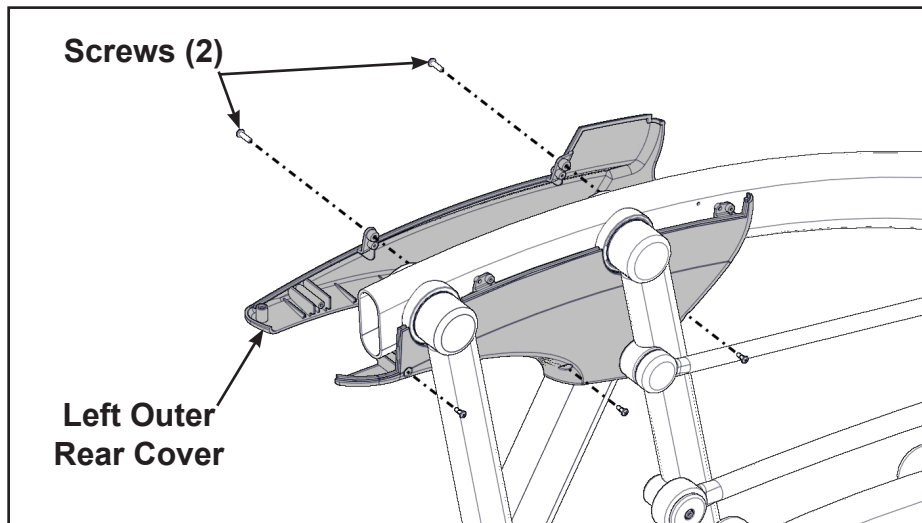

2. Install the left inner rear cover with two screws using a Phillips screwdriver.

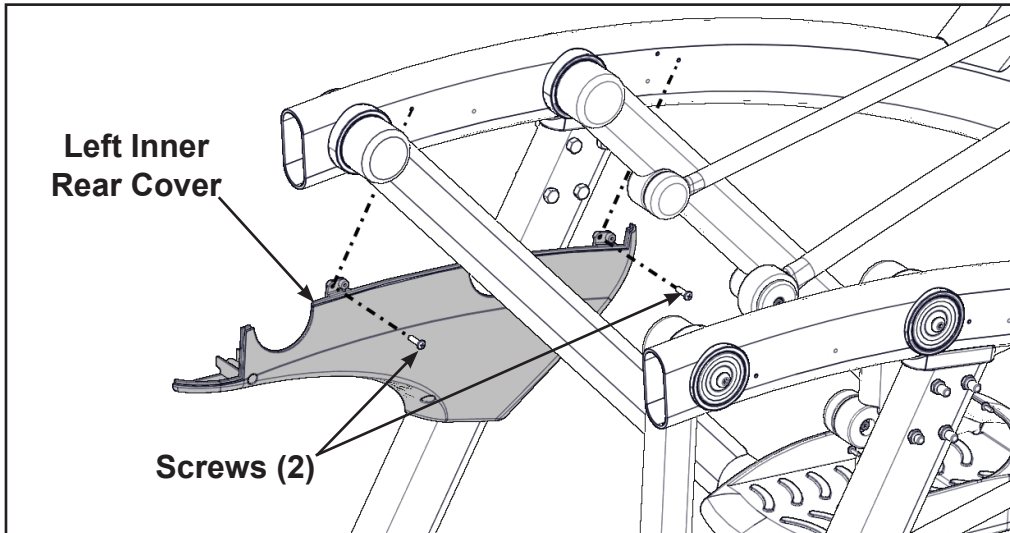

3. Install the left top rear cover with five screws using a Phillips screwdriver.

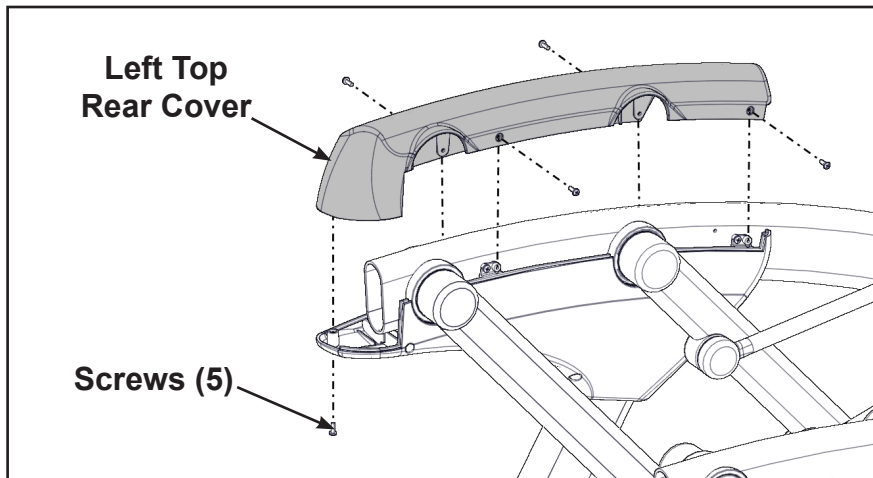

4. Install the right outer rear cover with two screws using a Phillips screwdriver.

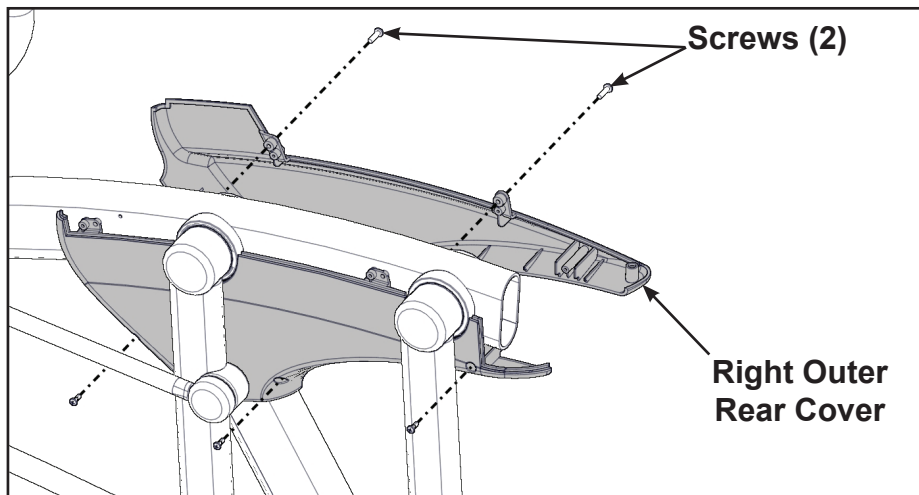

5. Install the right inner rear cover with two screws using a Phillips screwdriver.

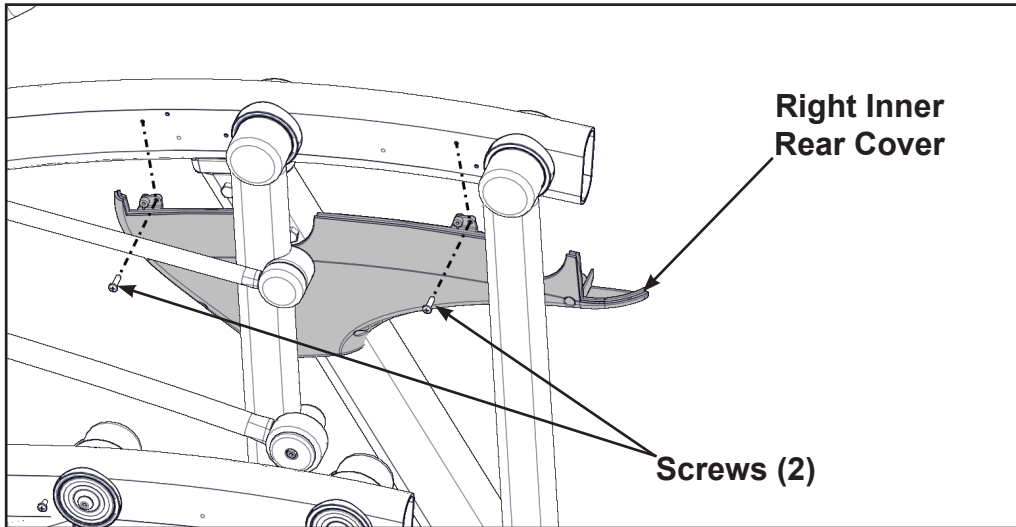

6. Install the right top rear cover with five screws using a Phillips screwdriver.

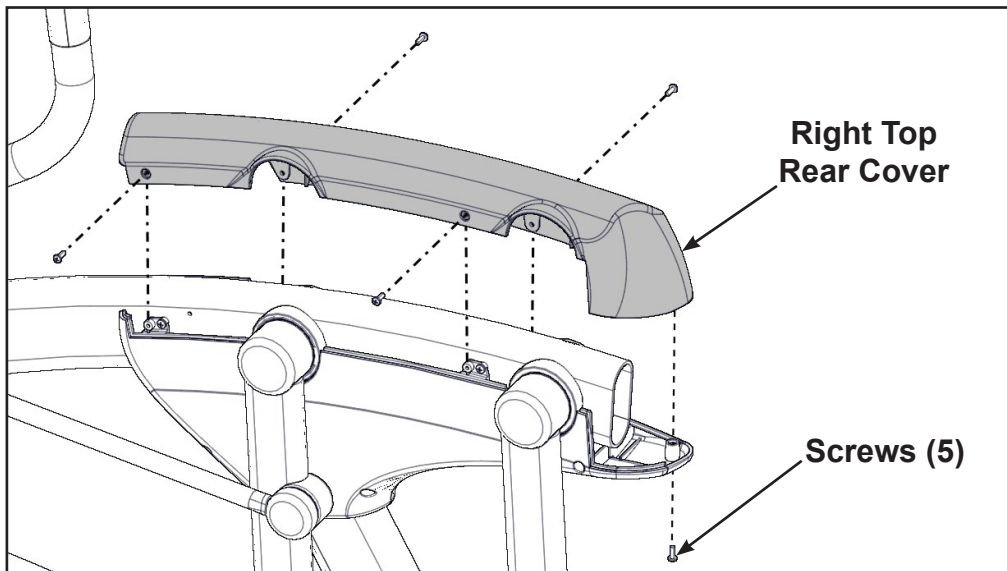

Attach foot pads

Have one person lift the unit while a second person places a foot pad under each of the two back feet.

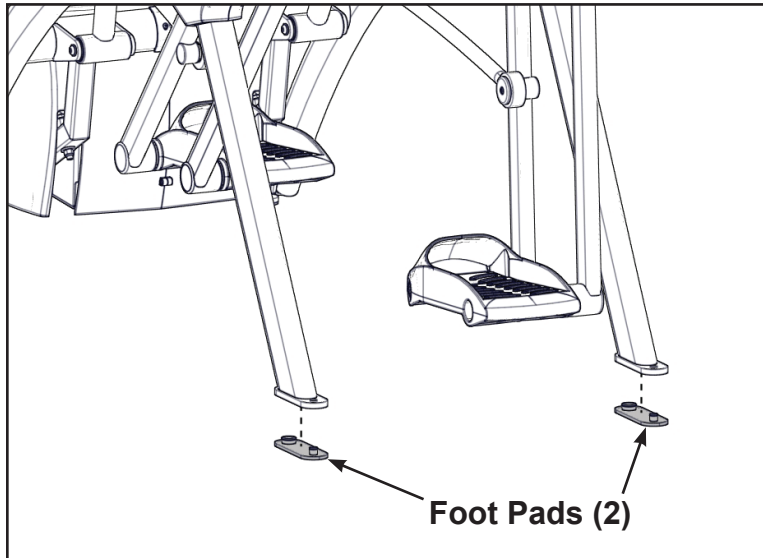

Level unit

Confirm unit is on a level surface. If not, use a 9/16" open-end wrench to adjust the leveling feet up or down.

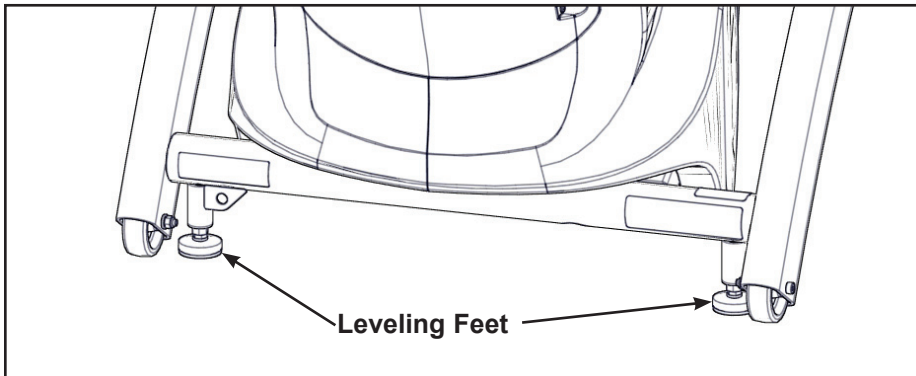

Visually inspect unit

1. Carefully remove any package material from arms and rest of unit.
2. Carefully examine the unit to ensure assembly is correct and complete.



Setup

Use the following instructions to setup the units settings.

1. Plug the optional power cord into a power outlet from a grounded circuit, See **Electrical Requirements**. Coil up the remainder of the power cord and place it out of the way. The control panel will light up and be in the Dormant Mode.
2. Hold the handrails to steady self while stepping into the foot plates.
3. Begin striding.

Setup options

1. Press and the hold the **SCAN/HOLD**  and **UP**  keys for 3 seconds.

Navigate through the setup menu with the **UP**  and **DOWN**  keys.



Press the **ENTER**  key once to enter setup values. Press again to save any changes and advance forward in the menu.

The Setup options are:

| | |
|-----------------------|---|
| Time | Set time display format. 12Hr A, 12Hr P or 24Hr (12 Hour AM, 12 Hour PM or 24 Hour). |
| Date | Date format is [YYYY] [MM] [DD]. Y - Year, M - Month and D - Day. |
| Distance Units | MI - Miles or KM - Kilometers. |
| Weight Units | LBS - Pounds, KG - Kilograms or Stone - Stones. |
| Pause | Set time length for Pause. OFF (Default), 0:30, 1:00 or 2:00 minutes. |
| Default Time | Set default workout time. 10, 20, 30 (Default), 60 or 90 minutes. |
| Max Time | Set maximum workout time. OFF (Unlimited), 20, 30, 40, 50, 60 (Default), 90 or 120 minutes. |
| Tone | Toggle console beeper On (Default) or OFF. |
| Dormant Style | Default, Default with time (Clock shown), Heart only or Energy Saver (All LED's off except for center dashes on membrane). |
| A/V | Set A/V option. none (Default), "UHF" or "FM". See <i>A/V Config and FM Radio Presets</i> for full configuration. If unit ships with embedded PEM this setup option is skipped. |
| Cloning | Transfer setup settings from one unit to others. See <i>Transfer settings to other units (optional)</i> . |

To reset setup options to default values

1. Press the **SCAN/HOLD**  key at the first setup option screen (Time). The console will display "RESET" and "[dEFA] [ULtS] [?]".

To exit without resetting, press the **UP**  and **DOWN**  keys or the **ENTER**  key.

2. Press the **SCAN/HOLD**  key to reset the console to the default values. The console will beep twice and display "RESET" and "[dEFA] [ULtS] [Set]".

Exit Set Up Mode.

1. Press the **Pause** key to exit Setup options.

Transfer settings to other units (optional)

After completing setup on one unit the settings can be loaded to other units. Settings can ONLY be transferred between 625A/625AT Arc Trainers. Do NOT transfer settings between other Arc Trainers, Bikes or Treadmills.

Tools Required

- Phillips screwdriver
- Cybox USB stick, (Not included). Ensure USB stick is blank.

Save settings to USB stick

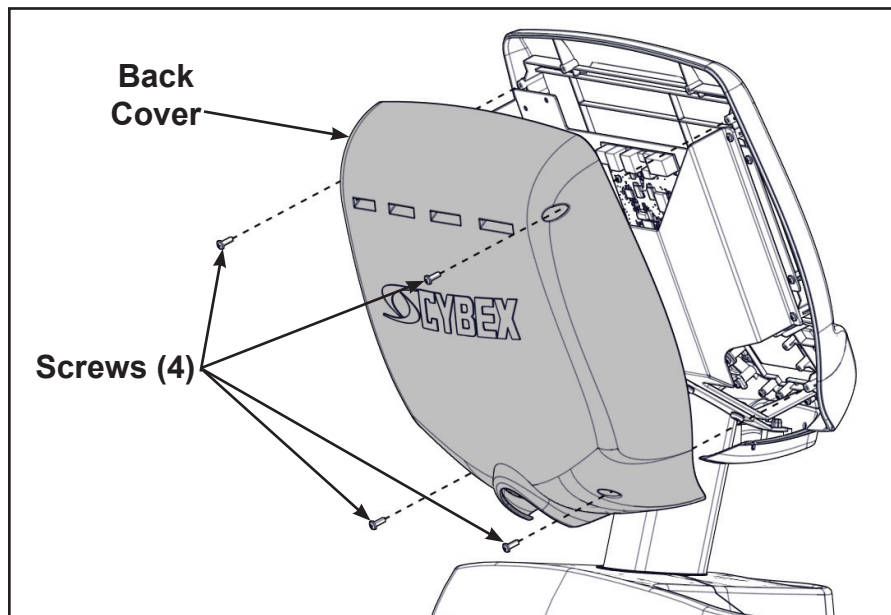

1. Remove the four screws from the back cover using a Phillips screwdriver.

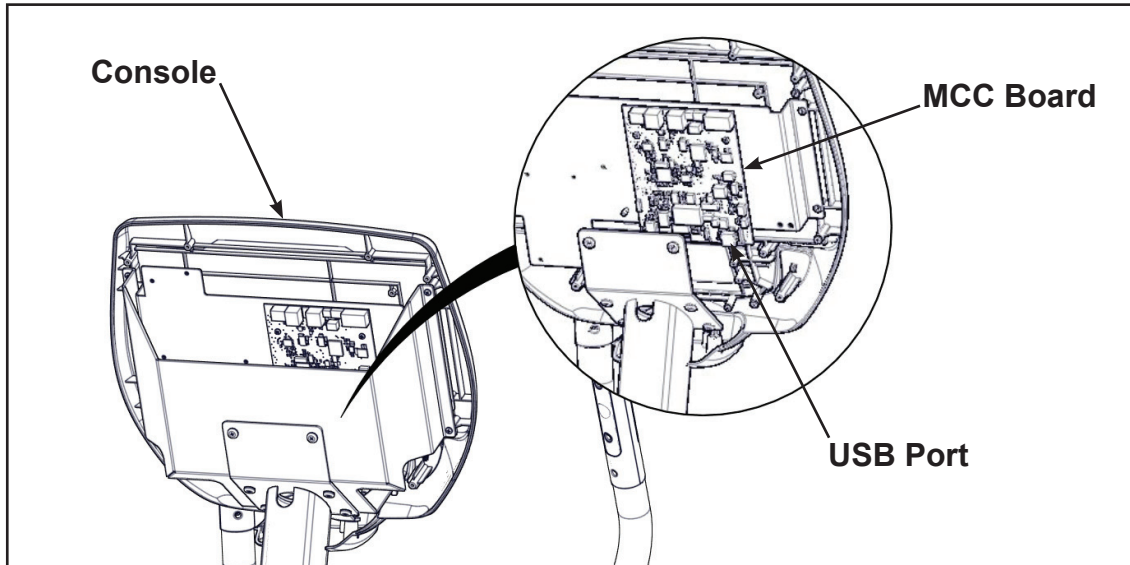

2. Remove back cover.

3. Plug the USB stick into the USB port of the MCC board.



4. Press and hold **Scan/Hold** and **TV Up**  for 3 seconds.
5. Press **Down**  to navigate to "Cloning". The console will display "SAVE [FILE] [on] [USB]"
6. Press **Enter** to save settings to USB stick. Console will beep four times when complete.
7. Press **Pause** and remove USB stick.
8. Install the back cover with four screws using a Phillips screwdriver.

Transfer settings to another unit



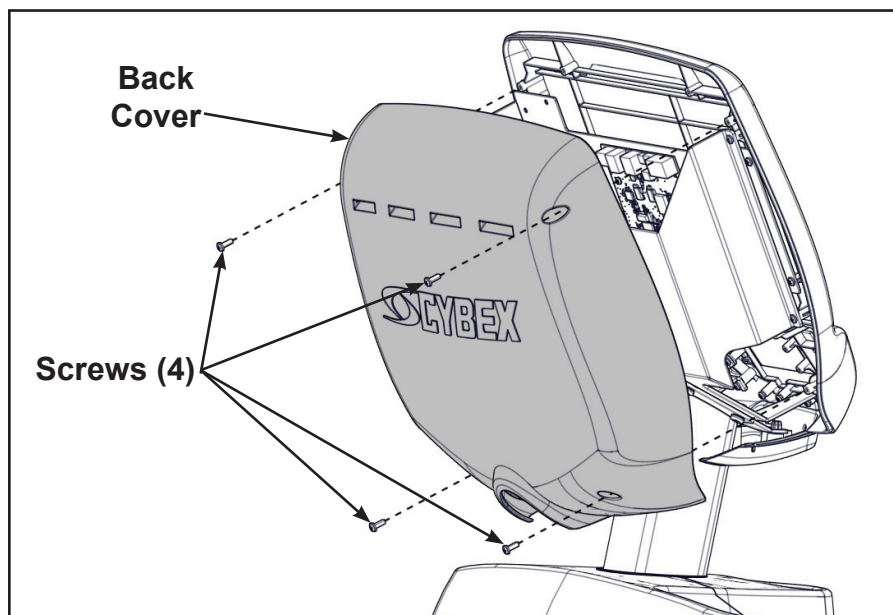

1. Remove the four screws from the back cover using a Phillips screwdriver.

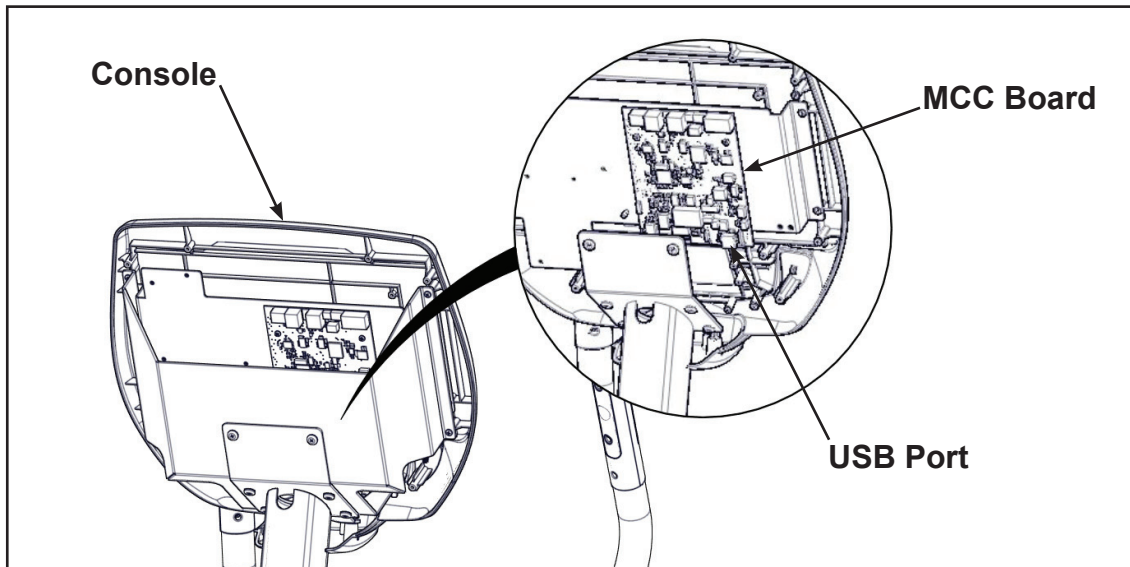

2. Remove back cover.

3. Plug the USB stick into the USB port of the MCC board.



4. Press and hold **Scan/Hold** and **Up**  for 3 seconds.
5. Press **Down**  to navigate to "Cloning". The console will display "LOAD [FILE] [oFF] [USB]". If "LOAD" is not displayed, press **Up**  or **Down**  to toggle setting from "SAVE" to "LOAD"
6. Press **Enter** to save settings to USB stick. Console will beep four times when complete.
7. Press **Pause** and remove USB stick.
8. Install the back cover with four screws using a Phillips screwdriver.

A/V Config and FM Radio Presets

Setting up the optional Cybox Wireless Audio Receiver Module for a 625A/625AT requires three steps:

- Determine the type of transmitter used (MYE 900MHz, Broadcast Vision 863MHz, etc. or TV FM).
- Assign a TV channel number to each transmitter on the 625A/625AT console.
- Add FM radio station presets (optional)

Tools Required:

- Headphones (not included)

Determine transmitter type

There are two types of transmitters UHF or TV FM. UHF transmitters will have TV's identified by number, example TV1. TV FM transmitters will have TV's identified with FM frequencies, example 93.1.

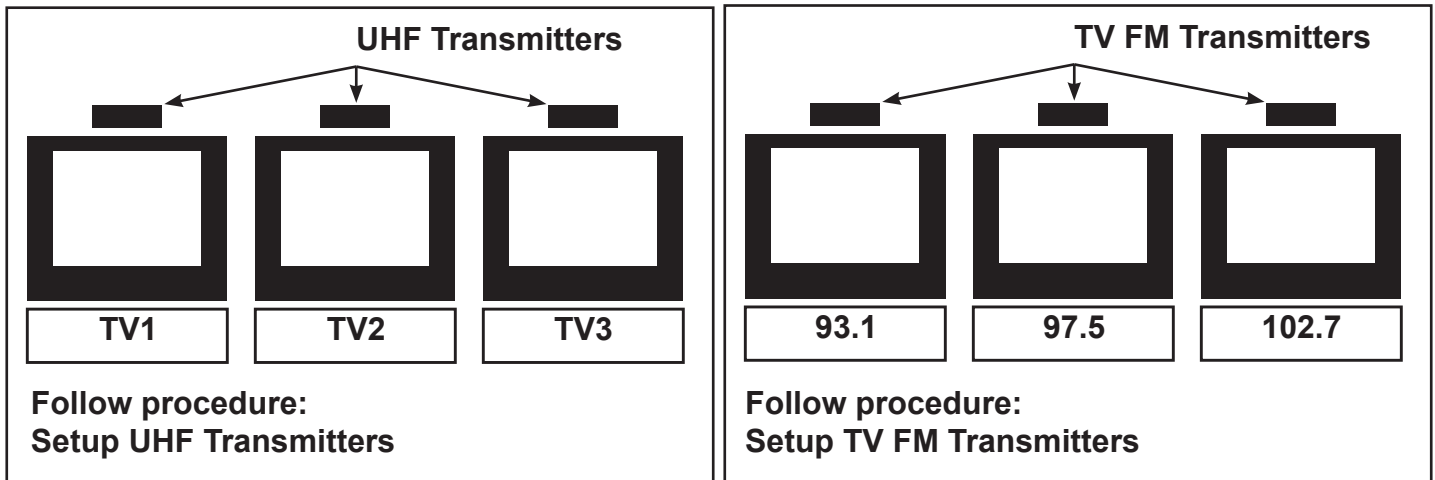

For TV FM transmitters, record FM frequencies for all TV's:

| 1 | 2 | 3 | 4 | 5 | 6 | 7 | 8 | 9 | 10 |
|---|---|---|---|---|---|---|---|---|----|
| | | | | | | | | | |

Membrane with Programs key

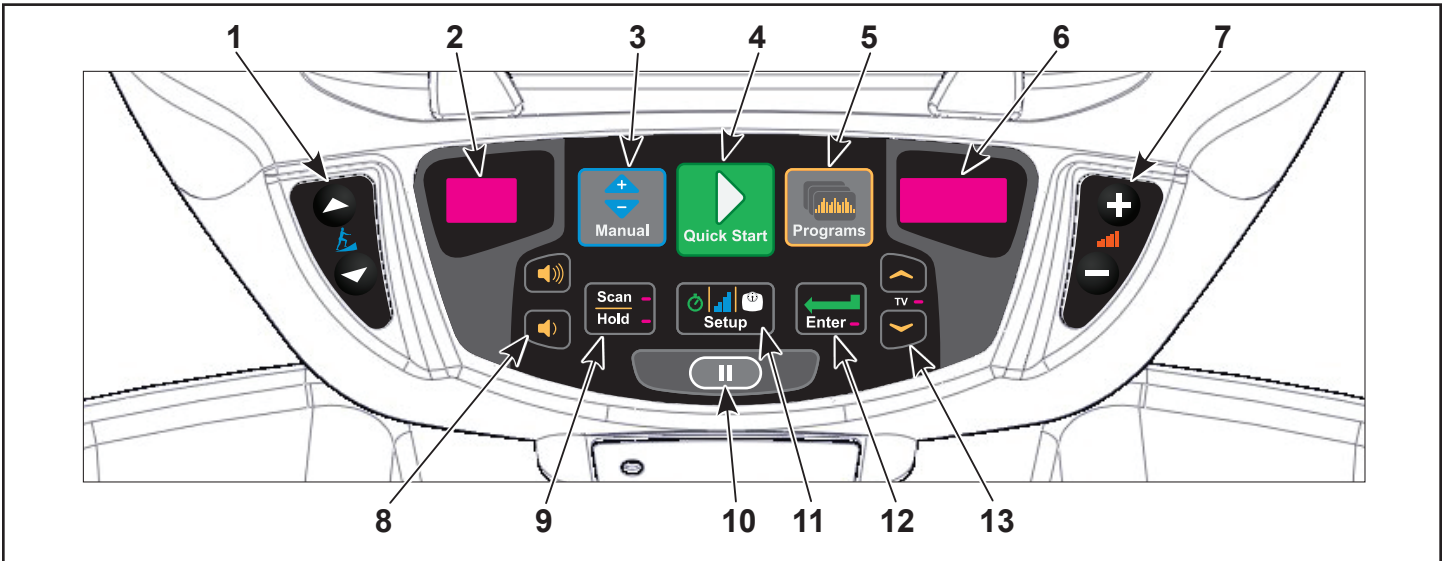



| | | |
|----|--------------------|---|
| 1 | Incline keys | Navigates through all stored channels as in User Mode |
| 2 | Incline display | Shows setting of receiver sensitivity as (n)ear or (F)ar |
| 3 | Manual key | Toggles near/far for receiver sensitivity |
| 4 | Quick Start key | Selects transmitter type Resets all stored TV channels when used |
| 5 | Programs key | Toggles setup for FM presets and back to TV channel setup |
| 6 | Resistance display | Shows 'FM' when storing FM radio station presets |
| 7 | Resistance keys | Toggles the display for Adding new channels or Deleting stored channels |
| 8 | Volume keys | Increase or decrease volume |
| 9 | Scan/Hold key | Scans for available TV transmitters, or will seek the next strongest FM station or FM transmitter frequency |
| 10 | Pause key | Stores and exits setup |
| 11 | Setup key | When storing FM presets, this button will clear all stored FM radio presets |
| 12 | Enter key | Enters menu, accepts value shown, moves forward in menu |
| 13 | Up/Down keys | Navigates TV channels or manually tunes FM frequencies |

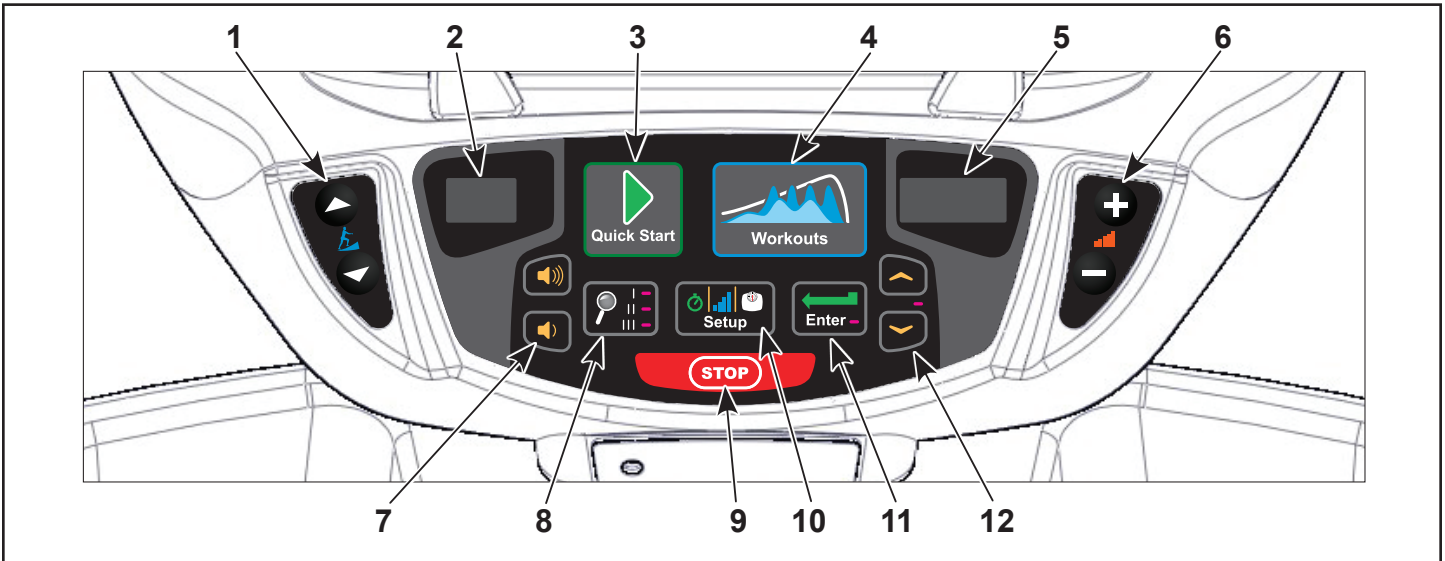

Membrane with Workouts key



| | | |
|----|--------------------|--|
| 1 | Incline keys | Navigates through all stored channels as in User Mode |
| 2 | Incline display | Shows setting of receiver sensitivity as (n)ear or (F)ar |
| 3 | Quick Start key | Selects transmitter type Resets all stored TV channels when used |
| 4 | Workouts key | Toggles setup for FM presets and back to TV channel setup |
| 5 | Resistance display | Shows 'FM' when storing FM radio station presets |
| 6 | Resistance keys | Toggles the display for Adding new channels or Deleting stored channels |
| 7 | Volume keys | Increase or decrease volume |
| 8 | Display option key | Scans for available TV transmitters, or will seek the next strongest FM station or FM transmitter frequency |
| 9 | STOP key | Stores and exits setup |
| 10 | Setup key | When storing FM presets, this button will clear all stored FM radio presets Toggles near/far for receiver sensitivity |
| 11 | Enter key | Enters menu, accepts value shown, moves forward in menu |
| 12 | Up/Down keys | Navigates TV channels or manually tunes FM frequencies |

A/V setup mode

1. Plug the optional power cord into a power outlet from a grounded circuit, See **Electrical Requirements**. Coil up the remainder of the power cord and place it out of the way. The control panel will light up and be in the Dormant Mode.
2. Hold the handrails to steady self while stepping into the foot plates.
3. Begin striding.
4. Press and hold **Scan/Hold** and **TV Up**  for 3 seconds. Display will show clock icon.
5. Press **Down**  to navigate to the "A/V" screen.

6. Press **Enter** to enter *setup mode*.
7. Press the **Up**  or **Down**  keys to change A/V type from “none” to “UHF or FM”.
8. Plug in headphones to listen for channels during setup.

Setup UHF Transmitters

For transmitter types 900 MHz, 863 MHz or 806 MHz. Use this procedure to associate channel numbers to your TV transmitters.







Pick transmitter type:

1. Enter A/V setup mode.
2. Select “UHF” and press the **ENTER**  key.
3. Press **Quick Start** to select your transmitter type from the available choices. The display will only show choices available under your transmitter type (900 MHz, 863 MHz or 806 MHz).

| 900 MHz System | 863 MHz System | 806 MHz System |
|--------------------------|------------------|----------------------------|
| “M 900” MYE | “M 863” MYE | “J1 806” Japan 14 channels |
| “C 900” Cardio Theater | “E 863” Exercise | “J2 806” Japan 30 channels |
| “E 900” Exercise | “A 863” Audeon | |
| “B 900” Broadcast Vision | | |





4. Press **Scan/Hold** to scan for available channels. The scan can take up to 10 seconds and then display “CH 1 of #”. The “#” symbol is total number of strong UHF channels found. Some of these channels may not be signals from the TV transmitters and need to be deleted.

Review channels:

1. Press **Up**  or **Down**  to listen to available channels with the headphones.
2. Delete unwanted channels by pressing Speed **Up**  or **Down**  to change the right LED window to [dEL]. Press **Enter** to delete channel. Repeat process for additional unwanted channels.
3. Adjust the Near/Far setting for channels that are available but not showing. Press **Manual** to change the setting from “F” (Far) to “n” (Near). Press **Scan/Hold** to re-scan for available channels.
4. Press **Up**  or **Down**  to scroll through and verify all TV channels. If all TV transmitters are stored, and they all correlate the TV number to the correct TV heard, setup is complete. If not you may need to re-scan or adjust the transmitter codes (see documentation for your transmitters to perform a code change).
5. Press **Pause** to exit setup. Transmitter setup complete.
6. Proceed to *Add FM Radio Stations (optional)*.







Setup TV FM Transmitters

If your TV's use FM transmitters, follow these instructions to assign a TV channel to each frequency.

1. Enter *A/V setup mode*.
2. Select "TV FM" and press the **ENTER**  key.
3. Press **Scan/Hold** to seek the next TV FM frequency or **Up**  or **Down**  to tune manually.
4. Press Speed **Up**  or **Down**  keys to add "[Add]" a channel. Press **Enter** to save channel, "std" (stored) will be displayed.
5. Repeat steps 3 and 4 to add all TV FM channels.
6. Press **Pause** to exit setup when all the TV's FM transmitter frequencies have a TV number. Transmitter setup complete.
7. Proceed to *Add FM Radio Stations (optional)*.





Add FM Radio Stations (optional)

If strong local FM Radio Stations are available in the area, you can set those as presets.

1. Enter *A/V setup mode*.
2. Press **Programs** to display "FM" on the console. The left numeric will display the next available channel and FM frequency.
3. Press **Scan/Hold** to seek the next FM station or **Up**  or **Down**  to tune manually.
4. Press Speed **Up**  or **Down**  keys to add "[Add]" a channel. Press **Enter** to save channel, "std" (stored) will be displayed.
5. Repeat steps 3 and 4 to save up to 32 FM radio stations.
6. Press **Pause** to exit setup when all FM radio stations are stored.
7. Press **Up**  or **Down**  to scroll through and verify all FM radio stations.





Adjust sound volumes

After completing setup, the sound volume should be adjusted between the TV transmitters and the FM radio stations. If FM radio stations are not set, adjust volume between all TV's.

1. Press **Up**  or **Down**  to select an FM radio station. This volume is not adjustable and is the base volume.
2. Press **Up**  or **Down**  to select a TV station.

- Adjust the volume of each TV to match an FM Radio Station or each other using the TV's remote control. The goal is for a volume setting of 10 on the treadmill to be the same for all TV and FM channels.
- Repeat procedure for all TV's.

Using the Cybox Wireless Audio Receiver





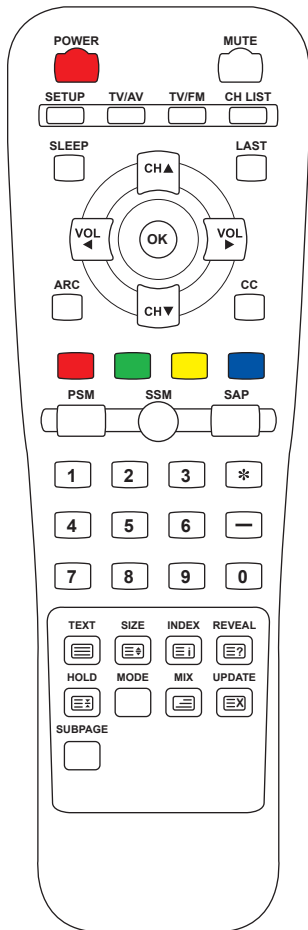

- Plug headphones into headphone jack.
- Press **Up**  or **Down**  to select TV or FM channels.
- Press volume **Up**  or **Down**  to adjust volume.

Setup Complete

E3 View Monitor Controls

The remote control is used to perform all setup operations for the E3 View Monitor.



| | | |
|---|---------|--|
|  | POWER | Turn the E3 View monitor on or off |
|  | SETUP | Enter or exit the Setup home screen |
|  | CH LIST | Channel list - List all available channels |
|  | CH▲ | Channel up - Navigate up through the on-screen menu |
|  | CH▼ | Channel up - Navigate down through the on-screen menu |
|  | VOL◀ | Volume left - Navigate left through the on-screen menu |
|  | VOL▶ | Volume right - Navigate right through the on-screen menu |



E3 View Monitor Setup

Access Setup Screen

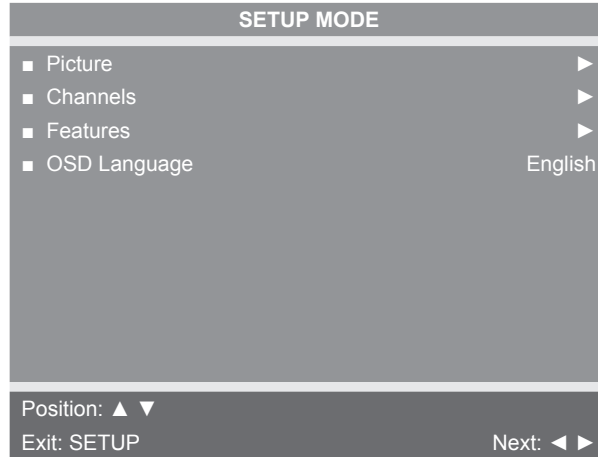



Press the **SETUP**  button to display the SETUP MODE screen on the E3 View Monitor. Follow procedure to setup the E3 View Monitor.

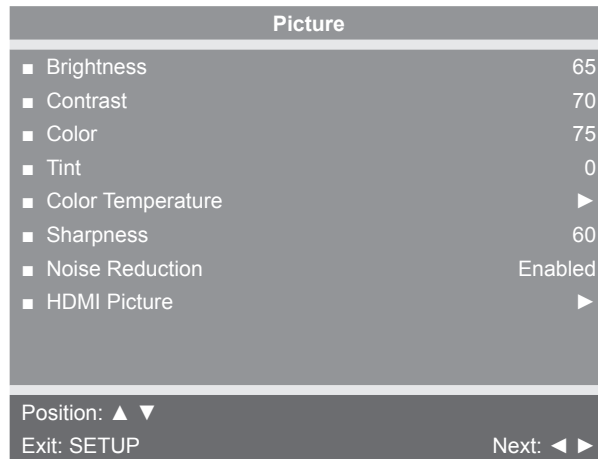

Picture

1. Press  or  to select **Picture**.
2. Press  to select access **Picture** menu.



3. Press  or  to select settings.
4. Press  or  to adjust settings.

Picture settings

| | |
|-------------------|---|
| Brightness | Adjust range from 1 to 100. Default is 65. |
| Contrast | Adjust range from 1 to 100. Default is 70. |
| Color | Adjust range from 1 to 100. Default is 75. |
| Tint | Adjust range from 1 to 100. Range is R50 to G50. Default is 0. |
| Color Temperature | Adjust color balance of Red, Green and Blue temperatures. |
| Sharpness | Adjust range from 1 to 100. Default is 60. |
| Noise Reduction | Select Enabled (Default) or Disabled. |
| HDMI Picture | Set to Auto or Adjust settings as needed. Available only when HDMI signal is present. |

5. Press the **SETUP**  button to return to SETUP MODE menu.

Channels

1. Press  or  to select **Channels**.
2. Press  to select access **Channels** menu.

ATSC Monitor





| Channels | |
|---------------------------|-----------|
| ■ Signal | Cable STD |
| ■ Auto Program | ▶ |
| ■ Add/Delete Channels | ▶ |
| ■ Parental Control | ▶ |
| ■ Default Channel | Last |
| ■ Channel Lock | Disabled |
| ■ Channel Memory Override | Enabled |

Position: ▲ ▼
Exit: SETUP Next: ◀ ▶

DVB-T Monitor

| Channels | |
|---------------------------|----------|
| ■ Auto Program | ▶ |
| ■ Manual Program | ▶ |
| ■ Add/Delete Channels | ▶ |
| ■ Parental Control | ▶ |
| ■ Default Channel | Last |
| ■ Channel Lock | Disabled |
| ■ Channel Memory Override | Enabled |





Position: ▲ ▼
Exit: SETUP Next: ◀ ▶

3. Press  or  to select settings.
4. Press  or  to adjust settings.

Channel settings



| | |
|-----------------------------|--|
| Signal (ATSC only) | Select Air, Cable STD, Cable IRC, or Cable HRC. |
| Auto Program | See Below |
| Manual Program (DVB-T only) | See Below |
| Add/Delete Channels | See Below |
| Parental Control | Block channels based on TV ratings. |
| Default Channel | Select channel to display on power up. Select from available channels or last. |
| Channel Lock | Select Enabled or Disabled. If enabled only one channel is shown, user cannot change channels. |
| Channel Memory Override | Select Enabled or Disabled. If enabled allows user to select any available channel. |

Auto Program (ATSC Monitor)

1. Press  to select **Auto Program**.
2. Press  to enter the menu.
3. Press  or  to select **Mode**.

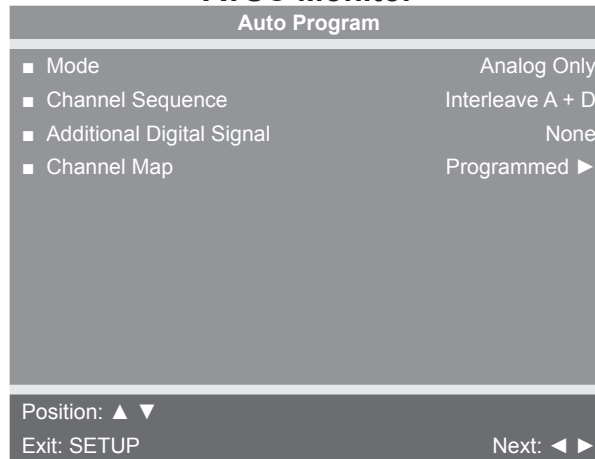

ATSC Monitor



4. Press  or  to set the scope of channel scanning.

- Analog Only (Default): TV searches for analog channels only.
- Digital Only: TV searches for digital channels only.
- Analog and Digital: TV searches for both analog and digital channels.

5. Press  to select **Channel Sequence**.

6. Press  or  to set the Channel Sequence in which the channels are displayed after searching.



- Interleave A+D: In the order of channel number regardless of the system.
- All A then D: Digital channels are displayed after all analog channels.

7. Press  or  to select **Additional Digital Signal**. Not available when **Mode** is set to Analog Only.

8. Press  or  to choose the **Additional Digital Signal** source. Choices are: None, Air, Cable STD, Cable IRC, or Cable HRC.

9. Press  to select **Channel Map**.

10. Press  to start auto programming. A confirmation menu will appear before proceeding.

11. Press  (Yes) to start auto programming. Press  (No) button to cancel the operation. The TV will now search all available channels with an on-screen progress percentage displayed. Any tuning Mode that includes Digital channels will require several minutes to complete auto programming.

This may take 20 or more minutes. If screen shuts off, Press the **POWER**  button to turn monitor on.

12. Press the **SETUP**  button to return to normal TV viewing once auto programming is complete.

13. Press the **CHANNEL LIST**  button to list programmed channels.

14. Press the **SETUP**  button to return to SETUP MODE menu.

Auto Program (DVB-T Monitor)

1. Tap  to select **Auto Program**.

2. Tap  to enter the menu.

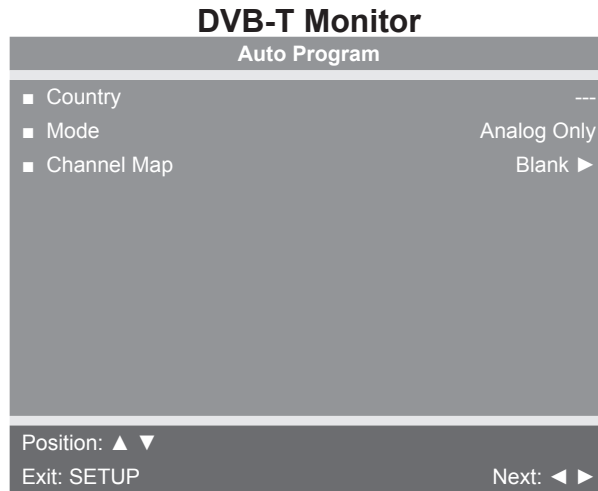

3. Tap  or  to select **Country**.



Available countries are:

Albania, Austria, Australia, Belgium, Bosnia, Bulgaria, China, Croatia, Czech, Denmark, Estonia, Finland, France, Germany, Greece, Hungary, Ireland, Italy, Kazakhstan, Latvia, Lithuania, Luxembourg, Morocco, Netherlands, Norway, Poland, Portugal, Romania, Russia, Serbia, Slovakia, Slovenia, Spain, Sweden, Switzerland, Turkey, Uk, and Ukraine.



4. Tap  or  to select **Mode**.

5. Tap  or  to set the scope of channel scanning.

- Analog Only (Default): TV searches for analog channels only.
- Digital Only: TV searches for digital channels only.
- Analog and Digital: TV searches for both analog and digital channels.

6. Tap  to select **Channel Map**.

7. Tap  to start auto programming. A confirmation menu will appear before proceeding.

8. Tap  (Yes) to start auto programming. Tap  (No) button to cancel the operation. The TV will now search all available channels with an on-screen progress percentage displayed. Any tuning Mode that includes Digital channels will require several minutes to complete auto programming.

This may take 20 or more minutes. If screen shuts off, **POWER**  button to turn monitor on.

9. Press the **SETUP**  button to return to normal TV viewing once auto programming is complete.

10. Tap the **CHANNEL LIST**  button to list programmed channels.

11. Press the **SETUP**  button to return to SETUP MODE menu.

Manual Program (ATSC and DVB-T)

1. Tap  to select **Manual Program**.

2. Tap  to enter the menu.

3. Tap  or  to select **Mode**.

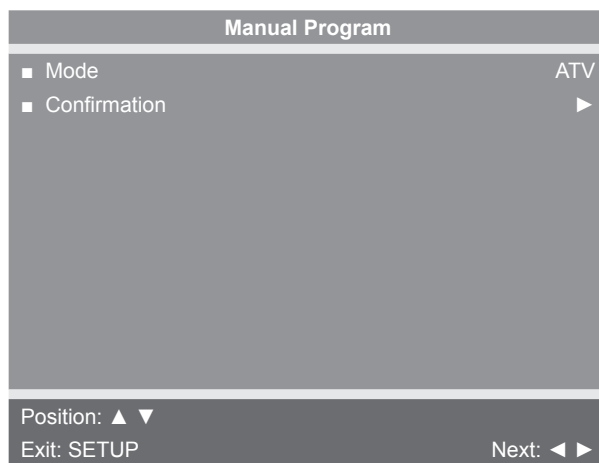

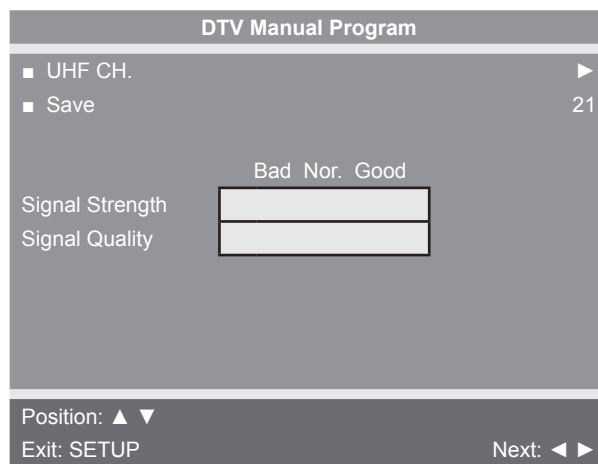
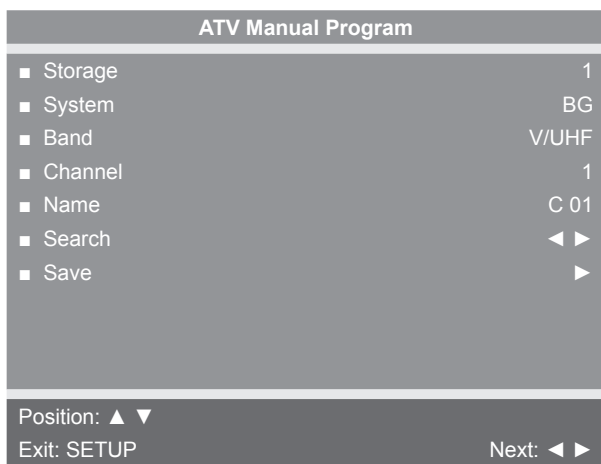

4. Tap  or  to select ATV or DTV.









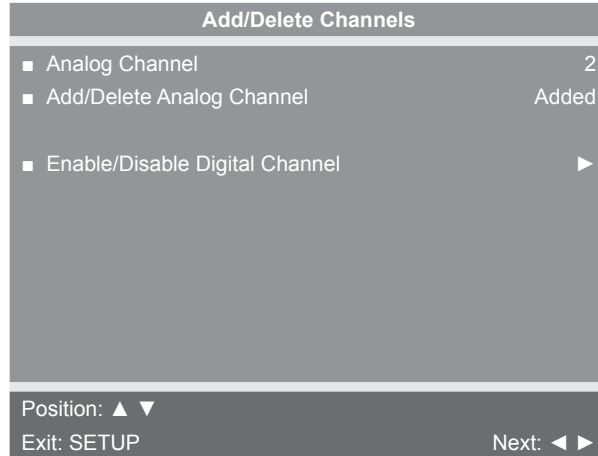









| | |
|----------|--|
| ATV Mode | Adjust settings for Storage, System, Band, Channel, Name, or Search. Select Save to save settings. |
| DTV Mode | Select UHF channel. Select Save to save settings. |

Add/Delete Channels (ATSC and DVB-T)

1. Press  to select **Add/Delete Channels**.
2. Press  to enter the Add/Delete Channels menu.



To add or delete an analog channel perform the following procedure. To enable or disable digital channels, go to step 7.

3. Press  or  to select the desired analog channel.
4. Press  or  to highlight **Add/Delete Analog Channel**.
5. Press  or  to select **Added** or **Deleted**.
6. Press the **SETUP**  button to return to the previous menu. To exit, Press the **SETUP**  button until the programming menus disappear. If there are more analog channels to be added or deleted, repeat steps 3 through 5.
7. Press  or  to highlight **Enable/Disable Digital Channel**.
8. Press  to select **Enable/Disable Digital Channel**. If there are not any channels programmed in the Service Level, “No Channels Present” will appear in the menu.
9. Press  or  to highlight the digital channel that needs to be enabled or disabled.
10. Press  or  to select **Enable** or **Disable**.
11. Press the **SETUP**  button to return to the previous menu.

Features

1. Press  or  to select **Features**.

2. Press  to select access **Features** menu.

ATSC Monitor

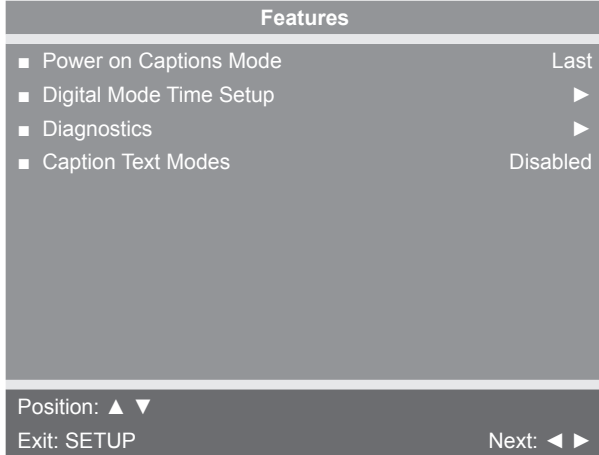

DVB-T Monitor

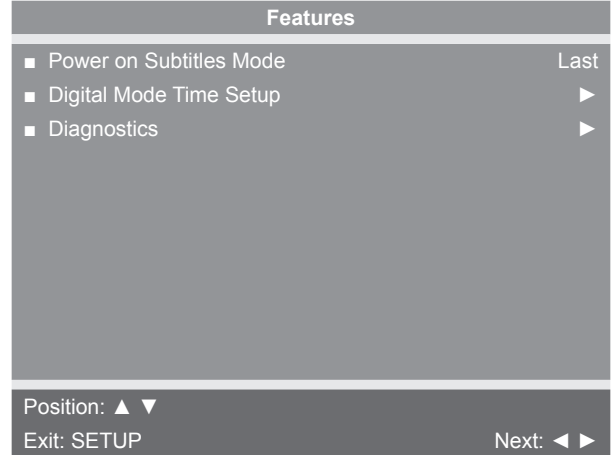

3. Press  or  to select settings.

4. Press  or  to adjust settings.

Testing Operation

Use the following instructions to test the full resistance and incline range of the unit:

1. Plug the optional power cord into a power outlet from a grounded circuit, See **Electrical Requirements**. Coil up the remainder of the power cord and place it out of the way. If you do not have the optional power supply, skip to step 3.
2. Verify the control panel will illuminate and is in *Dormant Mode*.
3. Hold the handrails to steady self while stepping into the foot plates.
4. Begin striding.
5. Tap **Quick Start**.
6. Run unit through full resistance range. First press the **RESISTANCE +** key until unit reaches its highest load (the display will show "100"). Then press the **RESISTANCE -** key until unit reaches its lowest load (the display will show "0"). The resistance should increase and decrease while striding.

When unit reaches the set incline and resistance, the displays will stop flashing and remain steadily illuminated to indicate the desired settings have been reached.

7. Run unit through full incline range. First press the **INCLINE** key until the unit reaches its highest incline (the display will show "20"). Then press the **INCLINE** key until unit reaches its lowest incline (the display will show "0"). The foot plates and arms should move freely during all incline levels.



WARNING: *Serious injury or death can occur. To avoid death or injury the following precautions must be observed. Wait until all moving parts come to a complete stop before dismounting. Failure to wait for complete stop can trip or injure user.*

8. Press the **Pause** key twice to bring the incline back to its start position, end the workout review, and return the display to *Dormant Mode*.
9. Wait until foot plates come to a complete stop before dismounting unit. Hold handrails to steady self while stepping off unit.

Operation

Intended Use

Intended use of this exercise equipment is to aid or improve general physical fitness and exercise.

Terms Used

Active Mode – Any time the unit is controlling resistance and accumulating workout data. Active Mode begins after pressing the **Quick Start** key, after completing the setup for a program, or by default if the initial screen times out and enters Quick Start Manual mode.

Auto-Scan – Display automatically cycles through workout data.

Cool Down – A reduction of work load for a short duration allows user to gently reduce heart rate. Cool Down occurs two minutes prior to completion of the program-controlled workout sessions.

Dormant Mode – Occurs when unit is plugged in with optional AC adapter and not in use.

Manual Mode – Manual Mode allows the user to adjust the Incline (0-20) and Resistance (0-100).

Pause Mode – Occurs only if the Pause feature is enabled and user selects the PAUSE key from Active Mode.

Quick Start – Press the **QUICK START** key to enter into Quick Start Manual Mode, where the user controls the Incline and Resistance as time counts up. Also occurs after 20 seconds of the user striding and not interacting with the console.









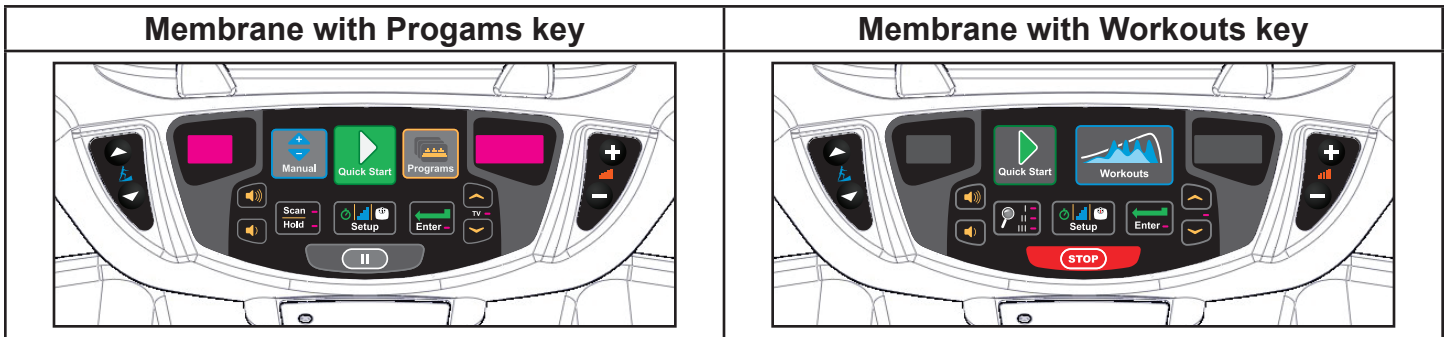

Workout Review – Review of the accumulated workout data will happen at the end of each workout session.



Read and understand all warnings and cautions in the Safety Section and all operation instructions in this chapter before operating unit.

User Control Symbols Used



| Control | Control Name | Description |
|---|------------------------|---|
|  | INCLINE UP | Adjust Incline up. |
|  | INCLINE DOWN | Adjust Incline down. |
|  | RESISTANCE UP | Adjust Resistance up. |
|  | RESISTANCE DOWN | Adjust Resistance down. |
|  | VOLUME UP | Adjust Volume up. |
|  | VOLUME DOWN | Adjust Volume down. |
|  | UP KEY | Adjust Time, Level, Weight, or Program up. A/V - Channel UP . iPod/iPhone/iPad - NEXT track (option) |
|  | DOWN KEY | Adjust Time, Level, Weight, or Program down. A/V - Channel DOWN . iPod/iPhone/iPad - PREVIOUS track (option) |
|  | PAUSE | If pause feature is enabled, press Pause once to enter pause mode. |
|  | STOP | Press STOP once to end the workout session and start the Workout Review. Press STOP again to exit to Dormant Mode. |

Console Display

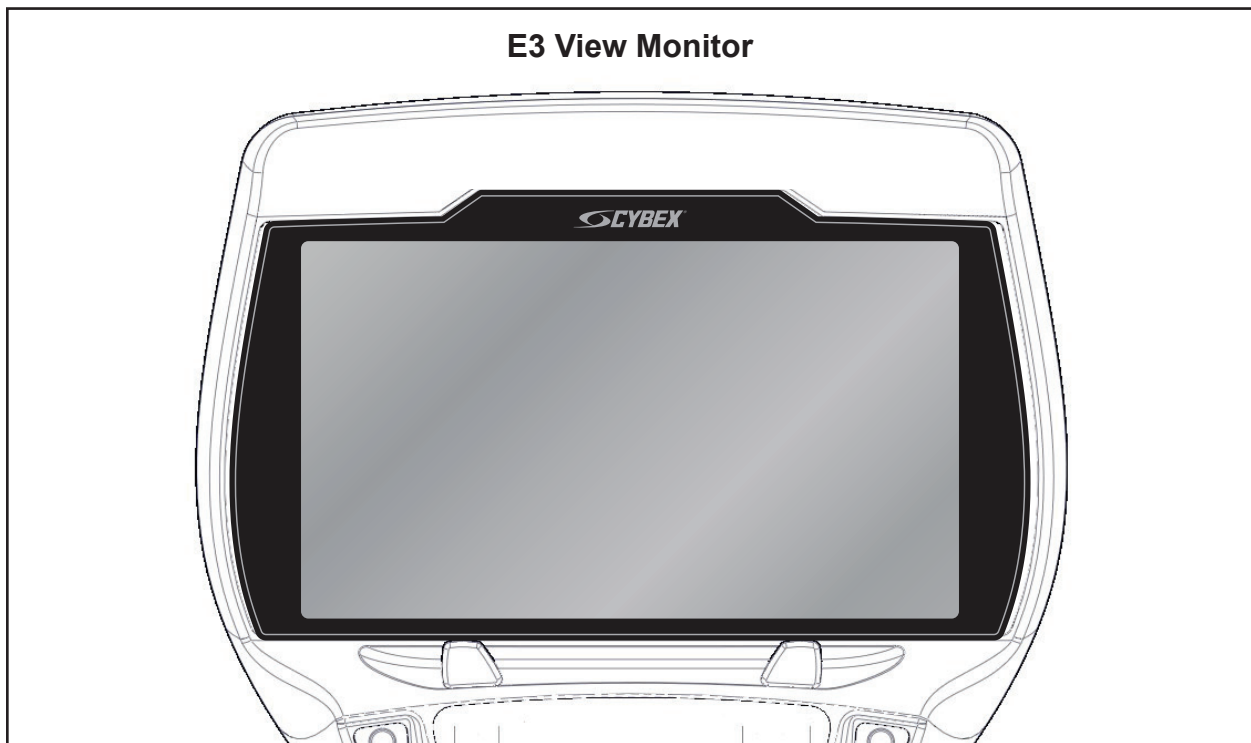
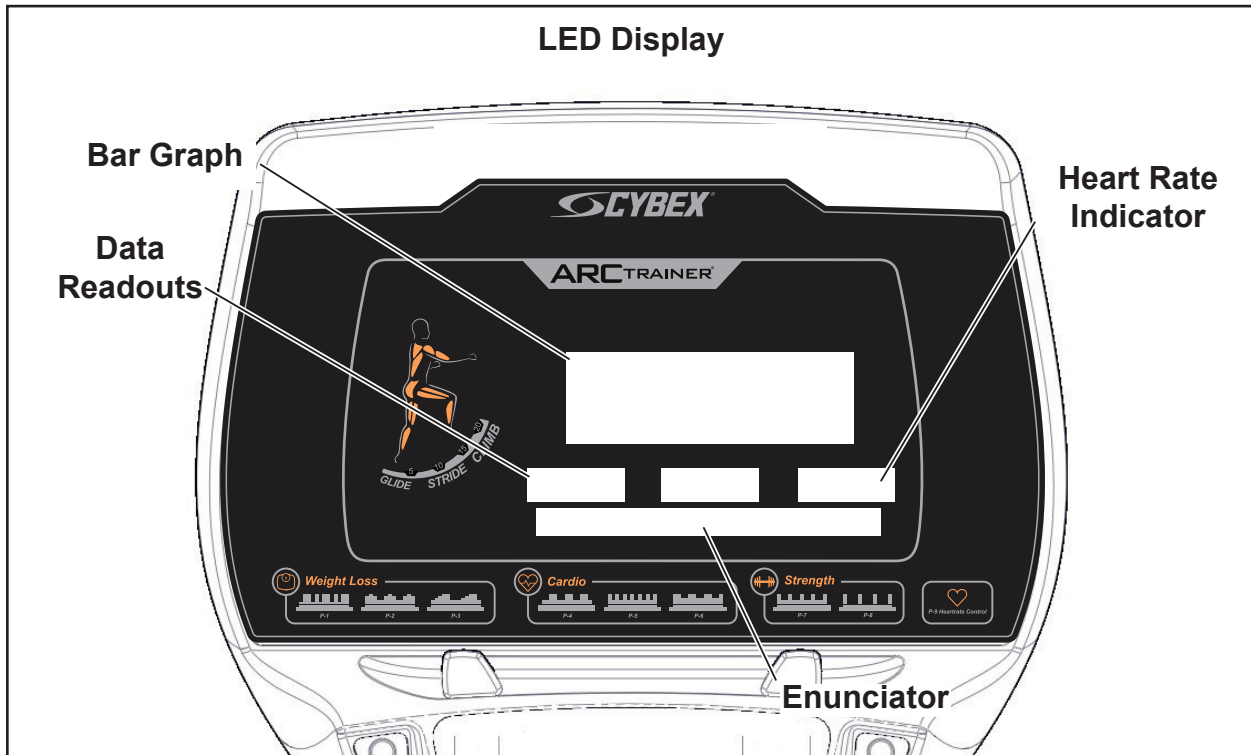

User Controls

Membrane with Programs key

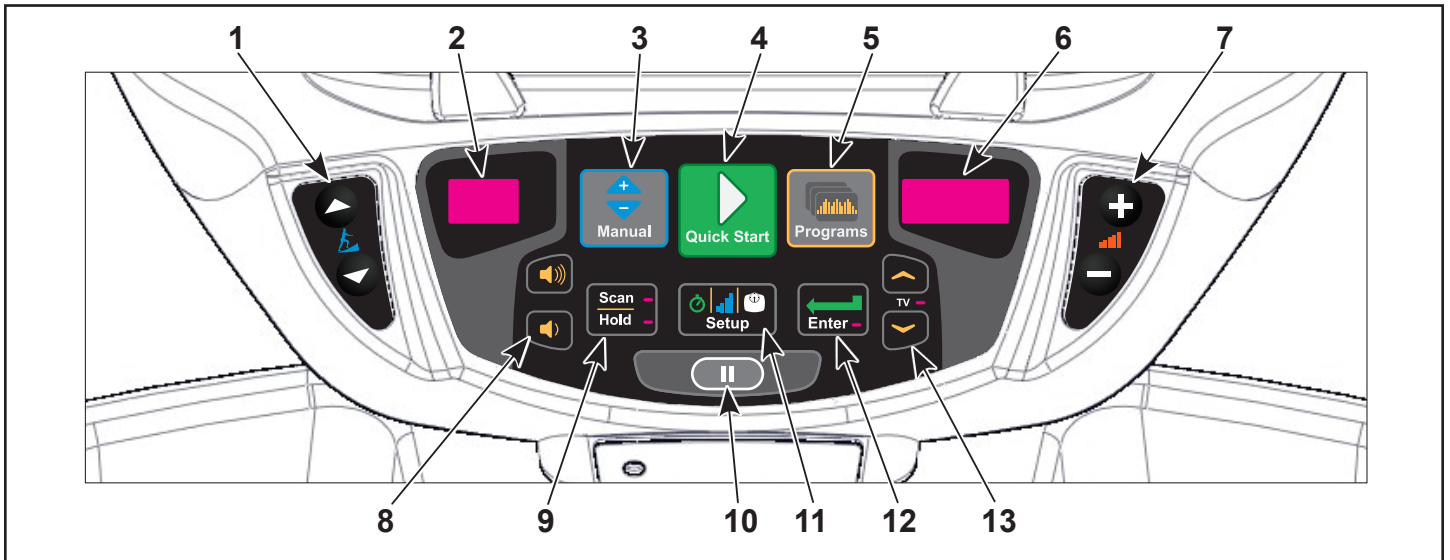

| | | | | | |
|---|-----------------|----|--------------------|----|--------------|
| 1 | Incline keys | 6 | Resistance display | 11 | Setup key |
| 2 | Incline display | 7 | Resistance keys | 12 | Enter key |
| 3 | Manual key | 8 | Volume keys | 13 | Up/Down keys |
| 4 | Quick Start key | 9 | Scan/Hold key | | |
| 5 | Programs key | 10 | Pause key | | |

Displays — Incline and Resistance are shown in the LED displays. The TV LED indicates when Up/Down keys are active to change channels.

Keys — User controls for Incline, Manual, Quick Start, Programs, Resistance, Volume, Scan/Hold, Pause, Setup, Enter and Up/Down.

Membrane with Workouts key

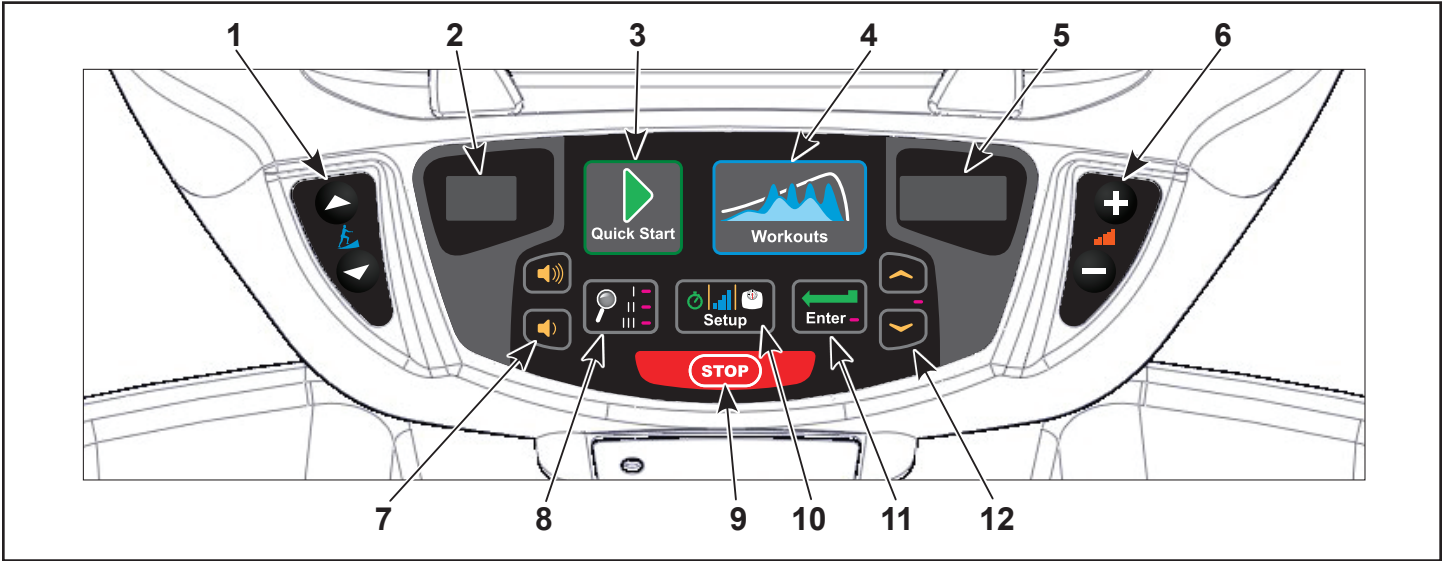

| | | | | | |
|---|--------------------|----|--------------------|----|--------------|
| 1 | Incline keys | 6 | Resistance keys | 11 | Enter key |
| 2 | Incline display | 7 | Volume keys | 12 | Up/Down keys |
| 3 | Quick Start key | 8 | Display option key | | |
| 4 | Workouts key | 9 | STOP key | | |
| 5 | Resistance display | 10 | Setup key | | |

Displays — Incline and Resistance are shown in the LED displays. The TV LED indicates when Up/Down keys are active to change channels.

Keys — User controls for Incline, Quick Start, Workouts, Resistance, Volume, Display option, STOP, Setup, Enter and Up/Down.

Mount and Dismount

 **WARNING:** *Serious injury or death can occur. To avoid death or injury the following precautions must be observed. Wait until all moving parts come to a complete stop and foot plates are in starting position before mounting or dismounting. Mounting or dismounting while foot plates are moving can trip or injure user.*

To mount unit safely:

1. Verify unit is off or in *Dormant Mode* and foot plates are completely stopped.
2. Grasp handrail and step carefully onto foot plates.

To dismount unit safely:

1. Wait until foot plates come to a complete stop.
2. Grasp handrails for support and carefully step off back of unit.

Emergency Dismount

If an emergency stop and dismount is required:

1. Grasp handrails for support.
2. Stop striding.
3. Wait until foot plates come to a complete stop.
4. Continue to hold handrails while carefully stepping off unit.

Range of Motion

The elevation is adjustable up or down in the shape of an arc. The lowest setting of 0 equates to an arc of 12 degrees, where the highest setting of 20 equates to an arc of 34.5 degrees. There is no difference in muscles used between different incline positions. Differences exist in the intensity of muscle activity.

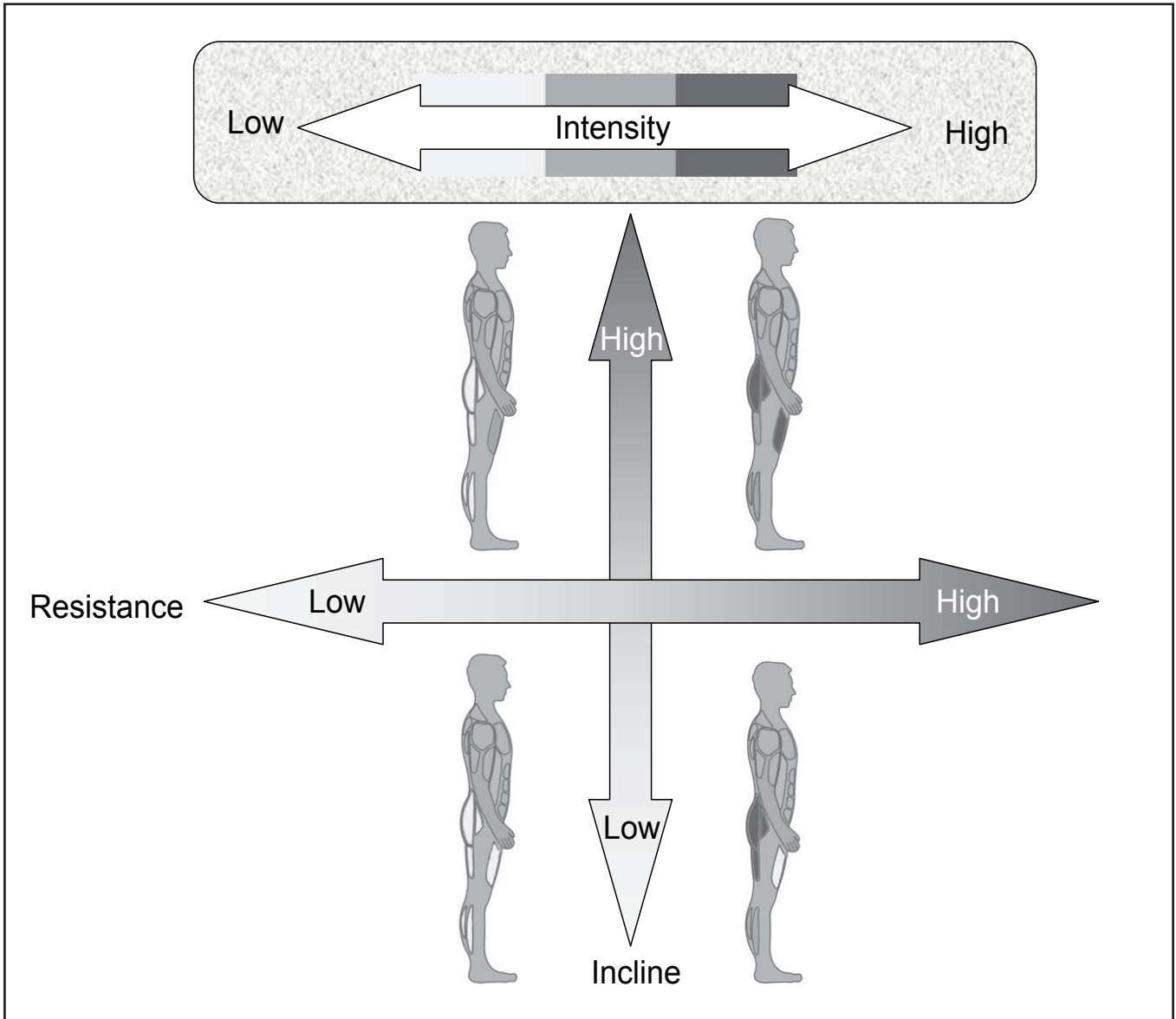

Quick Operation Guide

Maximum user weight is 400 lbs. (181 kg).

The following is a quick overview of the operation of the unit. For more information read *Detailed Operation Guide* in this chapter.







1. Verify foot plates are completely stopped.
2. Grasp handrail and step carefully onto foot plates. Begin striding.
3. Press the **Quick Start** key. The console will beep for one second and display "GO!".
4. Press the **Incline** ▲ ▼ keys to change the incline at any time. The left display will show incline.
5. Press the **Resistance** + – keys to change the resistance at any time. The right display will show the current resistance.
6. Press the **Pause** key at any time to pause. "Workout Review" is displayed, if pause is enabled, and the incline returns to 6%.

Detailed Operation Guide

Maximum user weight is 400 lbs. (181 kg).



1. Plug the optional power cord into a power outlet from a grounded circuit, See **Electrical Requirements**. Coil up the remainder of the power cord and place it out of the way. The control panel will light up and be in the Dormant Mode.
2. Verify foot plates are completely stopped.
3. Grasp handrail and step carefully onto foot plates. Begin striding.
4. Select **Manual**, **Quick Start** or **Programs**.

If **Manual** is selected, enter Time then Weight.

1. Adjust time with the **UP**  and **DOWN**  keys.
2. Press the **ENTER**  key to advance to weight settings.
3. Adjust weight with the **UP**  and **DOWN**  keys. For the most accurate resistance and calorie count, you must set your correct weight before beginning your workout (including clothing).
4. Press the **ENTER**  key to advance to weight settings. The console will beep for one second and display "GO!", and enter *Active Mode*.

If **Quick Start** is selected, The console will beep for one second, display "GO!", and enter *Active Mode*.



If **Programs** is selected, Select a program and setup options.

1. Select programs P-1 through P-9 with the **UP**  and **DOWN**  keys.
2. Press the **ENTER**  key to advance to setup options.

Setup options:

| | |
|--------------------------|--------------------------------------|
| Programs P-1 through P-8 | Time, Level, Weight |
| Heart Rate Control P-9* | Time, Weight, Age, Target Heart Rate |

*The Heart Rate Control program requires wearing a Polar® compatible chest strap (not included).

3. Use the **UP**  and **DOWN**  keys to increase or decrease each of the setup options.
Press the **ENTER**  key to advance to the next option.

For the most accurate resistance and calorie count, you must set your correct weight before beginning your workout (including clothing).

When selecting a program you must press the **Enter** key after each adjustment of *Time, Level, Weight, Age, or Target Heart Rate*.

After final selection has been made the console will beep for one second, display “GO!”, and enter *Active Mode*.

4. Begin striding.
5. Observe the control panel. The top center *Bar Graph* display shows a graphical representation of the relative MET level, and if in a program, will show the relative intensity changes that are coming up. The *Data Readouts* will start showing the workout data such as Distance, Calories, Heart rate (if available), METs and Time. The data displays will start by automatically shifting every 5 seconds.

Heart rate will be displayed in lieu of METs if a valid heart rate is available from a wireless chest strap (not included) or by holding the contact heart rate grips.

When you adjust incline or resistance in a program, the change will affect only the current segment. The program control will resume starting with the next segment. To increase or decrease overall intensity, adjust the resistance and/or the program level.

6. Press the **Incline**  keys to change the incline at any time. The left display will show incline.
7. Press the **Resistance** **+ –** keys to change the resistance at any time. The right display will show the current resistance.
8. Press the **Pause** key at any time to pause. “Workout Review” is displayed, if pause is disabled, and the incline returns to 6%.

When a program is complete the unit begins a countdown, “3...2...1” and sounds a tone for each count. Workout Review is displayed for the preset time or until you press the **Pause** key. The unit returns to *Dormant Mode*.

Program Selection



WARNING: *Serious injury or death can occur. To avoid death or injury the following precautions must be observed. Obtain a medical exam before beginning any exercise program. Begin comfortably with a lower level and progress with higher levels as you become acclimated.*

With the 625A and 625AT you may choose from *Quick Start, Manual Mode, or nine program choices*. Speed is never predetermined. Change speed by changing stride.

Manual Choices:

- **Quick Start** Press **Quick Start**. Control incline and resistance.
- **Manual Mode** Set a Time goal. Enter weight. Control incline and resistance.

Program Choices:

| Program | Levels | Settings |
|-----------------------------|--------|---|
| P1 Weight Loss 1 | 10 | Select time, level and weight. |
| P2 Weight Loss 2 | 10 | Select time, level and weight. |
| P3 Weight Loss 3 | 10 | Select time, level and weight. |
| P4 Cardio 1 | 10 | Select time, level and weight. |
| P5 Cardio 2 | 10 | Select time, level and weight. |
| P6 Cardio 3 | 10 | Select time, level and weight. |
| P7 Strength 1 | 10 | Select time, level and weight. |
| P8 Strength 2 | 10 | Select time, level and weight. |
| P9 Heart rate Control (HRC) | N/A | Select time, age, target heart rate and weight. |

See Appendix for Program Overviews

Data Readouts

As the user exercises, the unit keeps track of and displays the following data:

BPM (Beats Per Minute) – User's current heart rate. Heart rate will appear when a signal is introduced.

Calories – The total accumulated calories burned during workout.

Calories Per Hour – Calculation of present workload's energy exertion in Calories per Hour.

Distance – The total accumulated distance during workout. Depending on the defaults chosen, this measurement will show in English (miles) or Metric (kilometers). The unit uses a fixed 24" (61 cm) stroke, giving a travel distance of 48" (122 cm) per revolution. Distance = Strides per Minute x 24" (61 cm) x Time.

SPM (Strides per Minute) – The average number of strides per minute at current speed.

METs (Metabolic Equivalent) – Displayed only if no BPM signal is present. A MET is the metabolic equivalent of the energy expended by the human body at rest. Anything over one MET is considered exertion. METs are calculated by the display and updated every 1 – 1.2 seconds. METs = Cal/Hr X 2.2 / User Weight (in lbs.)

WATTS – The absolute meter-kilogram-second unit of power equal to the work done at the rate of one joule per second, equivalent to 1/746 horsepower.

Heart Rate Indicator





Contact Heart Rate – Lightly hold hand grips on the handlebar ensuring that hands are clean and contact both the front and back sensors of each grip. A heart rate will display in typically 30 seconds or less.

Factors that interfere with heart rate signal:

- hand lotions
- oils or body powder
- excessive dirt
- excessive movement
- body composition
- hydration
- too loose grip
- too tight grip
- resting or leaning on grips

Wireless Heart Rate – To use this feature, a Polar® compatible heart rate transmitter belt (not included) must be worn.

Once the actual heart rate is determined, the LED to the right of the *Data Readouts* is blinking to the displayed BPM and the Heart LED lights up. The color of the light represents a scale of low to high target heart rate.

| | | |
|---|--------------|------------------------------|
|  | Blue | 0 – 69 BPM |
|  | Green | 70 – 93 BPM |
|  | Yellow | 94 – 119 BPM (Fat Burn Zone) |
|  | Blood Orange | 120 – 169 (Cardio Zone) |
|  | Magenta | 170 and higher |

Maintenance

All preventive maintenance activities must be performed on a regular basis. Performing routine preventive maintenance actions can aid in providing safe, trouble-free operation of all Cybox Strength Systems equipment.

Cybox is not responsible for performing regular inspection and maintenance actions for your machines. Instruct all personnel in equipment inspection and maintenance actions and also in accident reporting/recording. Cybox representatives are available to answer any questions that you may have.

All inspections and repairs must be performed by trained service personnel only. Cybox will void warranty if non-Cybox replacement parts are used.



Warnings

 Read all warnings in this chapter and in the **Safety Section**.

Observe the following warnings and cautions:

- All maintenance activities shall be performed by qualified personnel. Failure to do so could result in serious injury.
- To prevent electrical shock, verify unit is unplugged from the electrical outlet before performing any cleaning or maintenance procedures. A charge can remain after unplugging the optional power cord.
- Keep wet items away from inside parts of unit.
- Performance level of equipment can be maintained only if it is examined regularly for damage and wear. Pay special attention to components most susceptible to wear.
- Replace worn or damaged components immediately and/or keep the equipment out of use until repair is completed.

Cleaning Unit

1. Spray a clean cloth with a mild cleaning agent, such as a water and dish soap solution.
2. Wipe unit.

Do not spray cleaning solution directly on unit. Direct spraying could cause damage to electronics and may void warranty.

After Each Use:

- Wipe up any liquid spills immediately.
- Wipe up any remaining perspiration from handles and painted surfaces.
- Be careful not to spill or get excessive moisture on the console and display overlays, as this might create an electrical hazard or cause failure of the electronics.
- Clean heart rate grips using a cloth dampened with a cleaning solution containing alcohol.

The heart rate grips are the only part of the unit where a cleaning solution containing alcohol should be used.

Preventive Maintenance Activities

Perform regular preventive maintenance to ensure normal operation of unit. Keep a log of all maintenance actions to assist in staying current with all preventive maintenance activities.

Cybex is not responsible for performing regular inspection and maintenance actions for your unit. Instruct all personnel in equipment inspection and maintenance actions and also in accident reporting/recording. Contact Cybex Customer Service at 888-462-9239 or 508-533-4300 for any preventive maintenance or service concerns.



Read and understand warnings listed in this chapter and in the **Safety Section**. Read and understand all instructions in this section.

During maintenance, disconnect the external power source. If unit has the optional AC Power Kit unplug the power cord from the power outlet.

For some maintenance activities it will be necessary to remove and replace the access cover.

Tool Required

Phillips screwdriver

Remove Access Cover

1. Remove the two lower screws securing the access cover using a Phillips screwdriver.

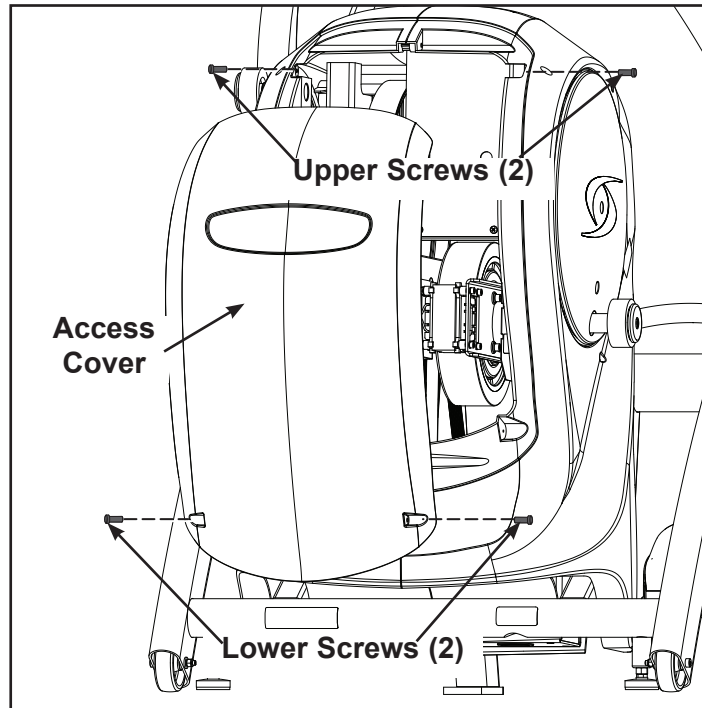

2. Remove two upper screws securing the access cover using a Phillips screwdriver. Refer to the above diagram.
3. Remove the access cover.



WARNING: *Serious injury or death can occur. To avoid death or injury the following precautions must be observed. Wait until flywheel cools before servicing. A hot flywheel may burn user.*

Drive Belts

There are two drive belts that may become loose, worn or cracked.

Unless the belts have been removed and not replaced properly, it is unlikely the belts will come loose or need to be re-tensioned.

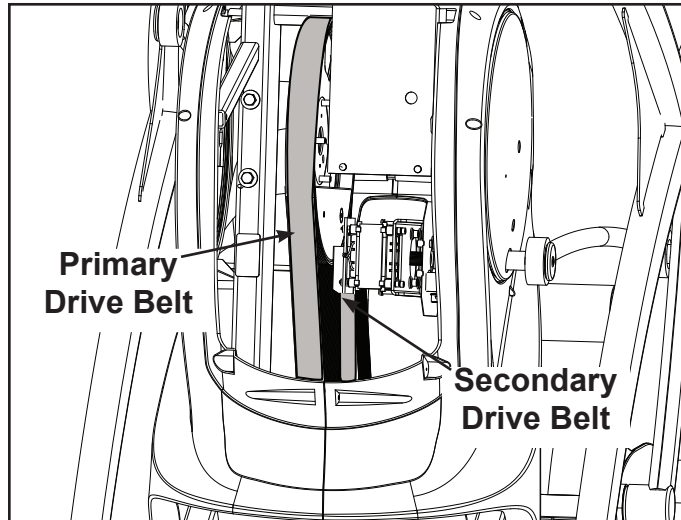

If a belt has cracks or appears worn, it must be replaced immediately by a qualified service technician.

Primary Belt – The wider of the two belts. It has grooves that keep it aligned on the large upper pulley.

Secondary Belt – The narrower of the two belts. It has grooves that keep it aligned on the flywheel's drive pulley.

Rechargeable Battery

The unit is designed with a 12 volt Lead-Acid rechargeable battery. The battery will recharge during regular operation of unit or when the optional power adapter is plugged in.

The display will indicate dashes in the incline display if the battery fails to provide enough energy. The unit will still function normally other than the disabling of the incline feature.

If the battery is completely discharged, the workout review will also be truncated if the user is not striding during the time period. See **Customer Service** for contact information to replace the battery or purchase the optional AC adapter kit.

WARNING: *Serious injury or death can occur. To avoid death or injury the following precautions must be observed. Battery replacement shall be performed by qualified service technician.*

Remove battery and dispose of safely before unit disposal.

Attach Access Cover

Do not over tighten screws.





1. Replace and tighten the two upper screws removed in step 2 **Remove Access Cover** using a Phillips screwdriver.
2. Replace and tighten the two lower screws removed in step 1 **Remove Access Cover** using a Phillips screwdriver.
3. Test unit for proper operation.

Recommended Service Schedule

All maintenance activities shall be performed by qualified personnel. Failure to do so could result in serious injury.

This is the minimum recommended service.

Determine distance

1. Verify foot plates are completely stopped.
2. Grasp handrail and step carefully onto foot plates. Begin striding.
3. Press and hold the **SCAN/HOLD**  and **DOWN**  keys for 3 seconds. A beep signifies the first screen of the Statistics menu.
4. Menu navigation is done two ways:
Up/Down - The **UP**  and **DOWN**  keys allow you to scroll up and down in the statistics menu.

The Statistics menu includes: Miles/Km, Hours, Starts, Battery and Error log.

5. The first menu item is **Miles/Km**.
6. Record Distance.
7. Navigate to menu item **Hours**.
8. Record Hours.
9. Exit Statistics menu by pressing the **Pause** key.

First 500 Miles (800 KM)

Follow this procedure to ensure the belts are tensioned properly and in good condition.

1. Remove access cover. (See previous procedure **Remove Access Cover**)
2. Pull down and roll each belt to examine the condition. If a belt has cracks or appears worn, it must be replaced immediately by a qualified service technician.

3. Attach access cover. (See previous procedure **Attach Access Cover**)

Every 5000 Miles (8000 KM)

Check drive belts for tension and wear. (See procedure First 500 Miles)

Move unit and vacuum underneath. Lift the rear of unit and roll it back from its present position. Vacuum underneath and return unit to normal position.

Clean inside unit.

1. Remove access cover. (See previous procedure **Remove Access Cover**)
2. Using a vacuum cleaner attachment or hand vacuum, clean the exposed components.
3. Remove dirt and debris from internal components.
4. Using a *dry* cloth, wipe all exposed areas.
5. Attach access cover. (See procedure **Attach Access Cover**)

Every 20,000 Miles (32000 KM)

Contact qualified service technician to check elevation assembly, replace any worn parts and lubricate elevation bushings.

Customer Service

Product Registration

To register product do the following:

1. Visit www.cybexintl.com.
2. Locate Product Registration in the Support section.
3. Fill out form completely.
4. Click the Submit button to register product.

Contacting Service

Hours of phone service are Monday through Friday from 8:30 a.m. to 6:00 p.m. Eastern Standard Time.

For Cybex customers living in the USA, contact Cybex Customer Service at 888-462-9239.

For Cybex customers living outside the USA, contact Cybex Customer Service at 508-533-4300 or fax 508-533-5183. email address internationaltechhelp@cybexintl.com

Find information on the web at www.cybexintl.com.

To contact us online go to www.cybexintl.com. Select Support > Service. In the left navigation panel, click Get Service - Service Request Form. Fill out form completely and click the Submit Query button.

Ordering Parts

To order parts online go to www.cybexintl.com. Select Support > Parts / Ordering. In the left navigation panel, click Parts Diagrams - Current Products. Select from the drop down boxes.

To speak with a customer service representative, call 888-462-9239 (for customers living within the USA) or 508-533-4300 (for customers outside the USA).

The following information located on the serial number decal will assist our Cybex representatives in serving you.

- Unit Serial Number, Product Name and Model Number
- Part Description and Part Number if you have it. All parts can be found on the web at
- www.cybexintl.com
- Shipping Address
- Contact Name
- Include a description of the problem.

In addition to your shipping address and contact name, your account number is helpful but not required. You may also fax orders to 508-533-5183.

Serial Number

The serial number can be found on the front of your unit. For your convenience, record your serial number below so that you will have it ready if you call Cybox Customer Service.

Serial Number _____

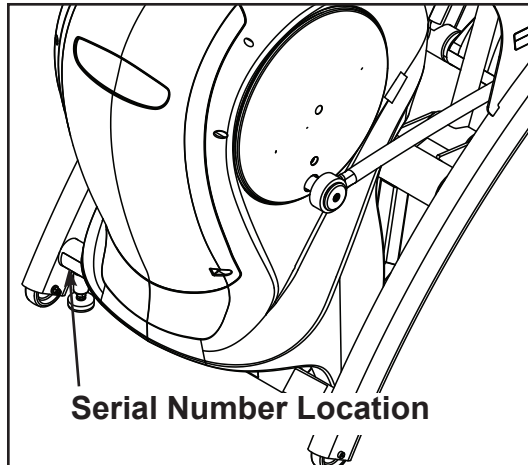

Return Material Authorization (RMA)

The Return Material Authorization (RMA) system is used when returning material for placement, repair or credit. The system assures that returned materials are properly handled and analyzed. Follow the following procedures carefully.

Contact your authorized Cybox dealer on all warranty-related matters. Your local Cybox dealer will request a RMA from Cybox, if applicable. Under no circumstances will defective parts or equipment be accepted by Cybox without proper RMA and an Automated Return Service (ARS) label.

Please contact Cybox Customer Service for the return of any item that is defective.

Provide the technician with a detailed description of the problem you are having or the defect in the item you wish to return. Provide the model and serial number of your Cybox equipment.

At Cybox's discretion, the technician may request that you return the problem part(s) to Cybox for evaluation and repair or replacement. The technician will assign you a RMA number and will send you an ARS label. The ARS label and the RMA numbers must be clearly displayed on the outside of the package that contains the item(s) to be returned. Include the description of the problem, the serial number of the equipment and the name and address of the owner in the package along with the part(s).

Merchandise returned without an RMA number on the outside of the package or shipments sent COD will not be accepted by the Cybox receiving department.

Damaged Parts

Materials damaged in shipment should not be returned for credit. Shipping damages are the responsibility of the carrier (UPS, Federal Express, trucking companies, etc.)

Apparent Damage

Upon receipt of your shipment, check all items carefully. Any damage seen with a visual check must be noted on the freight bill and signed by the carrier's agent. Failure to do so will result in the carriers refusal to honor your damage claim. The carrier will provide you with the required forms for filing such claims.

Concealed Damage

Damage not seen with a visual check upon receipt of a shipment but notices later must be reported to the carrier as soon as possible. Upon discovery of the damage, a written or phone request to the carrier asking them to perform an inspection of the materials must be made within ten days of the delivery date. Keep all shipping containers and packing materials as they will be needed in the inspection process. The carrier will provide you with an inspection report and the necessary forms for filing a concealed damage claim. Concealed damage claim is the carrier's responsibility.

Appendix - Program Overviews

P1: Weight Loss 1

The Weight Loss 1 program is a five-minute core program designed for low to medium intensity training that the user can sustain for an extended period of time. It builds from a low intensity baseline to include short bursts of higher resistance while the elevation increases by fifty percent for two-minutes. The constant variety provides for periods of higher expenditure and training effect without the introduction of undue fatigue allowing the user to perform for longer periods of time.

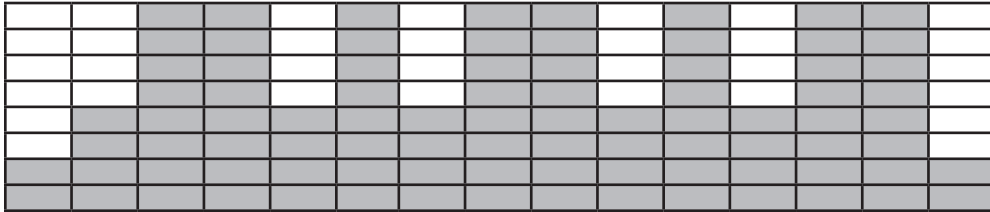

Resistance

| Time | :30 | :30 | :30 | :30 | 1:00 | 1:00 | 1:00 | 1:00 | 1:00 | :30 | :30 | :30 | :30 |
|------|---------|-----|-----|-----|------------------|------|------|------|------|-----------|-----|-----|-----|
| | Warm Up | | | | Program Segments | | | | | Cool Down | | | |
| | 1 | 2 | 3 | 4 | 1 | 2 | 3 | 4 | 5 | 1 | 2 | 3 | 4 |
| 10 | 5 | 10 | 15 | 20 | 25 | 45 | 45 | 25 | 45 | 20 | 15 | 10 | 5 |
| 9 | 5 | 10 | 15 | 20 | 25 | 40 | 40 | 25 | 40 | 20 | 15 | 10 | 5 |
| 8 | 5 | 10 | 15 | 20 | 25 | 35 | 35 | 25 | 35 | 20 | 15 | 10 | 5 |
| 7 | 5 | 5 | 10 | 15 | 25 | 40 | 40 | 25 | 40 | 15 | 10 | 5 | 5 |
| 6 | 5 | 5 | 10 | 15 | 25 | 35 | 35 | 25 | 35 | 15 | 10 | 5 | 5 |
| 5 | 5 | 5 | 10 | 15 | 25 | 30 | 30 | 25 | 30 | 15 | 10 | 5 | 5 |
| 4 | 5 | 5 | 5 | 10 | 15 | 25 | 25 | 15 | 25 | 10 | 5 | 10 | 8 |
| 3 | 5 | 5 | 5 | 10 | 15 | 20 | 20 | 15 | 20 | 10 | 5 | 10 | 8 |
| 2 | 5 | 5 | 5 | 5 | 5 | 15 | 15 | 5 | 15 | 5 | 4 | 3 | 3 |
| 1 | 5 | 5 | 5 | 5 | 5 | 10 | 10 | 5 | 10 | 5 | 4 | 3 | 3 |

Elevation

| Time | :30 | :30 | :30 | :30 | 1:00 | 1:00 | 1:00 | 1:00 | 1:00 | :30 | :30 | :30 | :30 |
|------|---------|-----|-----|-----|------------------|------|------|------|------|-----------|-----|-----|-----|
| | Warm Up | | | | Program Segments | | | | | Cool Down | | | |
| | 1 | 2 | 3 | 4 | 1 | 2 | 3 | 4 | 5 | 1 | 2 | 3 | 4 |
| 10 | 8 | 8 | 8 | 8 | 8 | 12 | 12 | 8 | 8 | 8 | 8 | 8 | 8 |
| 9 | 8 | 8 | 8 | 8 | 8 | 12 | 12 | 8 | 8 | 8 | 8 | 8 | 8 |
| 8 | 6 | 6 | 6 | 6 | 6 | 12 | 12 | 6 | 6 | 6 | 6 | 6 | 6 |
| 7 | 6 | 6 | 6 | 6 | 6 | 8 | 8 | 6 | 6 | 6 | 6 | 6 | 6 |
| 6 | 6 | 6 | 6 | 6 | 6 | 8 | 8 | 6 | 6 | 6 | 6 | 6 | 6 |
| 5 | 6 | 6 | 6 | 6 | 6 | 8 | 8 | 6 | 6 | 6 | 6 | 6 | 6 |
| 4 | 4 | 4 | 4 | 4 | 4 | 6 | 6 | 4 | 4 | 4 | 4 | 4 | 4 |
| 3 | 4 | 4 | 4 | 4 | 4 | 6 | 6 | 4 | 4 | 4 | 4 | 4 | 4 |
| 2 | 4 | 4 | 4 | 4 | 4 | 6 | 6 | 4 | 4 | 4 | 4 | 4 | 4 |
| 1 | 4 | 4 | 4 | 4 | 4 | 6 | 6 | 4 | 4 | 4 | 4 | 4 | 4 |

P2: Weight Loss 2

The Weight Loss 2 program is a five-minute core program that begins at a low intensity level and incrementally increases both resistance and elevation until peaking after three-minutes and remains at that level for one-minute before ramping back down to the initial level. The repetitive program is designed to encourage a transition in training intensity to encourage the development of aerobic and anaerobic energy systems.

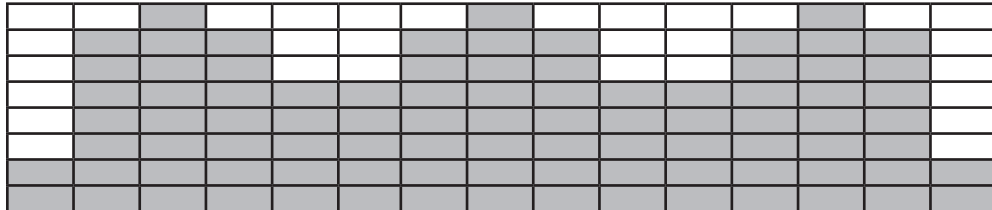

Resistance

| Time | :30 | :30 | :30 | :30 | 1:00 | 1:00 | 1:00 | 1:00 | 1:00 | :30 | :30 | :30 | :30 |
|------|---------|-----|-----|-----|------------------|------|------|------|------|-----------|-----|-----|-----|
| | Warm Up | | | | Program Segments | | | | | Cool Down | | | |
| | 1 | 2 | 3 | 4 | 1 | 2 | 3 | 4 | 5 | 1 | 2 | 3 | 4 |
| 10 | 20 | 25 | 30 | 40 | 50 | 65 | 80 | 65 | 50 | 40 | 30 | 25 | 20 |
| 9 | 20 | 25 | 30 | 35 | 50 | 60 | 75 | 60 | 50 | 35 | 30 | 25 | 20 |
| 8 | 20 | 25 | 30 | 35 | 45 | 55 | 70 | 55 | 45 | 35 | 30 | 25 | 20 |
| 7 | 15 | 20 | 25 | 35 | 45 | 50 | 65 | 50 | 45 | 35 | 25 | 20 | 15 |
| 6 | 15 | 20 | 25 | 30 | 40 | 45 | 60 | 45 | 40 | 30 | 25 | 20 | 15 |
| 5 | 10 | 15 | 20 | 20 | 40 | 40 | 55 | 40 | 40 | 20 | 20 | 15 | 10 |
| 4 | 10 | 10 | 15 | 15 | 30 | 35 | 50 | 35 | 30 | 15 | 15 | 10 | 10 |
| 3 | 5 | 5 | 10 | 10 | 20 | 20 | 40 | 20 | 20 | 10 | 10 | 5 | 5 |
| 2 | 5 | 5 | 10 | 10 | 20 | 20 | 40 | 20 | 20 | 10 | 10 | 5 | 5 |
| 1 | 5 | 5 | 10 | 10 | 15 | 20 | 35 | 20 | 15 | 10 | 10 | 5 | 5 |

Elevation

| Time | :30 | :30 | :30 | :30 | 1:00 | 1:00 | 1:00 | 1:00 | 1:00 | :30 | :30 | :30 | :30 |
|------|---------|-----|-----|-----|------------------|------|------|------|------|-----------|-----|-----|-----|
| | Warm Up | | | | Program Segments | | | | | Cool Down | | | |
| | 1 | 2 | 3 | 4 | 1 | 2 | 3 | 4 | 5 | 1 | 2 | 3 | 4 |
| 10 | 6 | 8 | 10 | 10 | 12 | 16 | 20 | 16 | 12 | 10 | 10 | 8 | 6 |
| 9 | 6 | 8 | 10 | 10 | 11 | 15 | 19 | 15 | 11 | 10 | 10 | 8 | 6 |
| 8 | 6 | 8 | 8 | 8 | 10 | 14 | 18 | 14 | 10 | 8 | 8 | 8 | 6 |
| 7 | 6 | 8 | 8 | 8 | 9 | 13 | 17 | 13 | 9 | 8 | 8 | 6 | 6 |
| 6 | 6 | 8 | 8 | 8 | 8 | 12 | 16 | 12 | 8 | 8 | 8 | 6 | 6 |
| 5 | 6 | 8 | 8 | 8 | 7 | 11 | 14 | 11 | 7 | 8 | 8 | 6 | 6 |
| 4 | 6 | 8 | 8 | 8 | 6 | 9 | 12 | 9 | 6 | 8 | 8 | 6 | 6 |
| 3 | 6 | 8 | 8 | 8 | 5 | 8 | 10 | 8 | 5 | 8 | 8 | 6 | 6 |
| 2 | 6 | 8 | 8 | 8 | 4 | 6 | 8 | 6 | 4 | 8 | 8 | 6 | 6 |
| 1 | 6 | 8 | 8 | 8 | 3 | 5 | 6 | 5 | 3 | 8 | 8 | 6 | 6 |

P3: Weight Loss 3

The Weight Loss 3 program is a three-minute thirty-second core program designed to give the user an intense workout. Users will experience moderate resistance and elevation at the beginning to simulate the start of a climb and will crest at peak elevation gain and difficult resistance after two-minutes. The resistance then returns to the preliminary level and the core program repeats itself for the next hill.

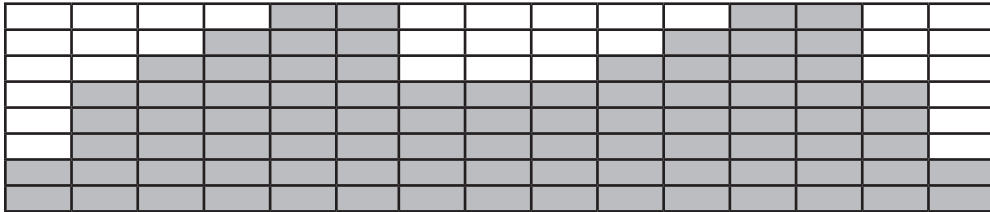

Resistance

| Time | :30 | :30 | :30 | :30 | :30 | :30 | :30 | :30 | :30 | :30 | :30 | :30 | :30 | :30 | :30 |
|------|---------|-----|-----|-----|------------------|-----|-----|-----|-----|-----|-----|-----------|-----|-----|-----|
| | Warm Up | | | | Program Segments | | | | | | | Cool Down | | | |
| | 1 | 2 | 3 | 4 | 1 | 2 | 3 | 4 | 5 | 6 | 7 | 1 | 2 | 3 | 4 |
| 10 | 20 | 30 | 40 | 50 | 50 | 55 | 65 | 75 | 80 | 50 | 50 | 50 | 40 | 30 | 20 |
| 9 | 20 | 30 | 40 | 45 | 45 | 50 | 60 | 70 | 75 | 45 | 45 | 45 | 40 | 30 | 20 |
| 8 | 20 | 30 | 35 | 40 | 40 | 45 | 55 | 65 | 75 | 40 | 40 | 40 | 35 | 30 | 20 |
| 7 | 15 | 25 | 35 | 35 | 35 | 45 | 50 | 60 | 70 | 35 | 35 | 35 | 35 | 25 | 15 |
| 6 | 15 | 25 | 30 | 35 | 35 | 40 | 50 | 55 | 65 | 35 | 35 | 35 | 30 | 25 | 15 |
| 5 | 15 | 25 | 30 | 30 | 30 | 35 | 45 | 50 | 60 | 30 | 30 | 30 | 30 | 25 | 15 |
| 4 | 10 | 20 | 25 | 30 | 25 | 30 | 40 | 50 | 55 | 25 | 25 | 30 | 25 | 20 | 10 |
| 3 | 10 | 20 | 25 | 25 | 20 | 30 | 40 | 45 | 50 | 20 | 20 | 25 | 25 | 20 | 10 |
| 2 | 10 | 15 | 20 | 25 | 20 | 25 | 35 | 40 | 45 | 20 | 20 | 25 | 20 | 15 | 10 |
| 1 | 10 | 10 | 15 | 15 | 20 | 20 | 30 | 35 | 40 | 20 | 20 | 15 | 15 | 10 | 10 |

Elevation

| Time | :30 | :30 | :30 | :30 | :30 | :30 | :30 | :30 | :30 | :30 | :30 | :30 | :30 | :30 | :30 |
|------|---------|-----|-----|-----|------------------|-----|-----|-----|-----|-----|-----|-----------|-----|-----|-----|
| | Warm Up | | | | Program Segments | | | | | | | Cool Down | | | |
| | 1 | 2 | 3 | 4 | 1 | 2 | 3 | 4 | 5 | 6 | 7 | 1 | 2 | 3 | 4 |
| 10 | 6 | 8 | 10 | 12 | 16 | 16 | 18 | 20 | 20 | 14 | 14 | 12 | 10 | 8 | 6 |
| 9 | 6 | 6 | 8 | 10 | 14 | 16 | 16 | 18 | 20 | 13 | 13 | 10 | 8 | 6 | 6 |
| 8 | 6 | 6 | 8 | 8 | 14 | 14 | 16 | 18 | 18 | 12 | 12 | 8 | 8 | 6 | 6 |
| 7 | 6 | 6 | 8 | 8 | 12 | 14 | 14 | 16 | 18 | 11 | 11 | 8 | 8 | 6 | 6 |
| 6 | 6 | 6 | 6 | 8 | 12 | 12 | 14 | 16 | 16 | 10 | 10 | 8 | 6 | 6 | 6 |
| 5 | 6 | 6 | 6 | 6 | 10 | 12 | 12 | 14 | 16 | 9 | 9 | 6 | 6 | 6 | 6 |
| 4 | 4 | 4 | 4 | 6 | 10 | 10 | 12 | 14 | 14 | 8 | 8 | 6 | 4 | 4 | 4 |
| 3 | 4 | 4 | 4 | 6 | 8 | 10 | 10 | 12 | 14 | 7 | 7 | 6 | 4 | 4 | 4 |
| 2 | 4 | 4 | 4 | 4 | 8 | 8 | 10 | 12 | 12 | 6 | 6 | 4 | 4 | 4 | 4 |
| 1 | 4 | 4 | 4 | 4 | 6 | 8 | 8 | 10 | 12 | 5 | 5 | 4 | 4 | 4 | 4 |

P4: Cardio 1

The Cardio 1 program is a four-minute core program designed for medium intensity workouts. Users will experience intervals of moderate resistance and elevation at the beginning to simulate the start of a climb and greater resistance and steeper elevation after two-minutes. The resistance then returns to the preliminary level and the core program repeats itself for the next interval.

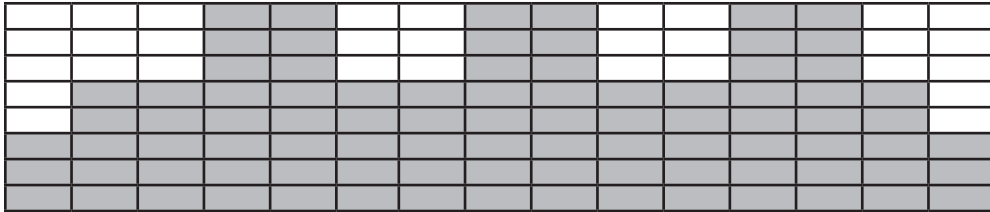

Resistance

| Time | :30 | :30 | :30 | :30 | 2:00 | 2:00 | :30 | :30 | :30 | :30 |
|------|---------|-----|-----|-----|------------------|------|-----------|-----|-----|-----|
| | Warm Up | | | | Program Segments | | Cool Down | | | |
| | 1 | 2 | 3 | 4 | 1 | 2 | 1 | 2 | 3 | 4 |
| 10 | 20 | 25 | 30 | 35 | 40 | 60 | 35 | 30 | 25 | 20 |
| 9 | 20 | 25 | 30 | 35 | 40 | 50 | 35 | 30 | 25 | 20 |
| 8 | 15 | 20 | 25 | 30 | 35 | 45 | 30 | 25 | 20 | 15 |
| 7 | 15 | 20 | 25 | 30 | 35 | 40 | 30 | 25 | 20 | 15 |
| 6 | 15 | 15 | 20 | 25 | 30 | 35 | 25 | 20 | 15 | 15 |
| 5 | 15 | 15 | 20 | 25 | 30 | 25 | 25 | 20 | 15 | 15 |
| 4 | 10 | 10 | 15 | 20 | 25 | 30 | 20 | 15 | 10 | 10 |
| 3 | 10 | 10 | 15 | 20 | 25 | 25 | 20 | 15 | 10 | 10 |
| 2 | 10 | 10 | 10 | 15 | 20 | 20 | 15 | 10 | 10 | 10 |
| 1 | 10 | 10 | 10 | 10 | 15 | 15 | 10 | 10 | 10 | 10 |

Elevation

| Time | :30 | :30 | :30 | :30 | 2:00 | 2:00 | :30 | :30 | :30 | :30 |
|------|---------|-----|-----|-----|------------------|------|-----------|-----|-----|-----|
| | Warm Up | | | | Program Segments | | Cool Down | | | |
| | 1 | 2 | 3 | 4 | 1 | 2 | 1 | 2 | 3 | 4 |
| 10 | 6 | 8 | 10 | 12 | 12 | 20 | 12 | 10 | 8 | 6 |
| 9 | 6 | 6 | 8 | 10 | 10 | 20 | 10 | 8 | 6 | 6 |
| 8 | 6 | 6 | 8 | 10 | 10 | 18 | 10 | 8 | 6 | 6 |
| 7 | 6 | 6 | 6 | 8 | 8 | 18 | 8 | 6 | 6 | 6 |
| 6 | 6 | 6 | 6 | 8 | 8 | 16 | 8 | 6 | 6 | 6 |
| 5 | 6 | 6 | 6 | 6 | 6 | 16 | 6 | 6 | 6 | 6 |
| 4 | 6 | 6 | 6 | 6 | 6 | 14 | 6 | 6 | 6 | 6 |
| 3 | 4 | 4 | 6 | 6 | 6 | 14 | 6 | 6 | 4 | 4 |
| 2 | 4 | 4 | 6 | 6 | 6 | 12 | 6 | 6 | 4 | 4 |
| 1 | 4 | 4 | 6 | 6 | 6 | 12 | 6 | 6 | 4 | 4 |

P5: Cardio 2

The Cardio 2 program is a two-minute core program utilizing a 1:1 work to rest ratio. It is designed to improve both aerobic and anaerobic capabilities as users will face a high level of resistance for one minute followed by a one-minute recuperation period before performing the work interval again. The elevation remains constant throughout the program.

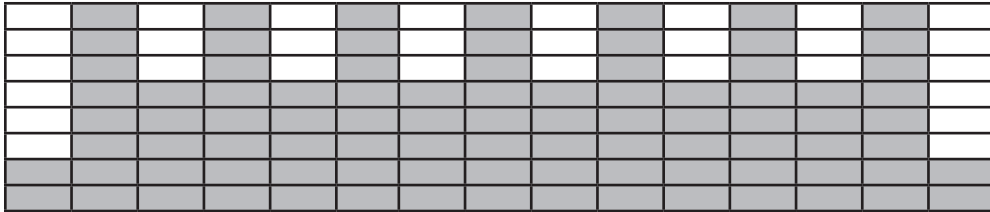

Resistance

| Time | :30 | :30 | :30 | :30 | 1:00 | 1:00 | :30 | :30 | :30 | :30 |
|------|---------|-----|-----|-----|------------------|------|-----------|-----|-----|-----|
| | Warm Up | | | | Program Segments | | Cool Down | | | |
| | 1 | 2 | 3 | 4 | 1 | 2 | 1 | 2 | 3 | 4 |
| 10 | 20 | 30 | 35 | 40 | 80 | 50 | 40 | 35 | 30 | 20 |
| 9 | 15 | 25 | 30 | 35 | 75 | 50 | 35 | 30 | 25 | 15 |
| 8 | 15 | 20 | 25 | 30 | 75 | 45 | 30 | 25 | 20 | 15 |
| 7 | 10 | 20 | 25 | 30 | 70 | 45 | 30 | 25 | 20 | 10 |
| 6 | 10 | 20 | 25 | 30 | 70 | 40 | 30 | 25 | 20 | 10 |
| 5 | 10 | 15 | 20 | 25 | 65 | 40 | 25 | 20 | 15 | 10 |
| 4 | 15 | 20 | 20 | 25 | 65 | 35 | 25 | 20 | 20 | 15 |
| 3 | 10 | 10 | 15 | 20 | 60 | 35 | 20 | 15 | 10 | 10 |
| 2 | 5 | 10 | 15 | 20 | 60 | 30 | 20 | 15 | 10 | 5 |
| 1 | 5 | 10 | 15 | 15 | 55 | 30 | 15 | 15 | 10 | 5 |

Elevation

| Time | :30 | :30 | :30 | :30 | 1:00 | 1:00 | :30 | :30 | :30 | :30 |
|------|---------|-----|-----|-----|------------------|------|-----------|-----|-----|-----|
| | Warm Up | | | | Program Segments | | Cool Down | | | |
| | 1 | 2 | 3 | 4 | 1 | 2 | 1 | 2 | 3 | 4 |
| 10 | 8 | 8 | 12 | 16 | 20 | 20 | 16 | 12 | 8 | 8 |
| 9 | 8 | 8 | 12 | 16 | 20 | 20 | 16 | 12 | 8 | 8 |
| 8 | 8 | 8 | 12 | 12 | 16 | 16 | 12 | 12 | 8 | 8 |
| 7 | 8 | 8 | 12 | 12 | 16 | 16 | 12 | 12 | 8 | 8 |
| 6 | 8 | 8 | 12 | 12 | 16 | 16 | 12 | 12 | 8 | 8 |
| 5 | 8 | 8 | 8 | 12 | 12 | 12 | 12 | 8 | 8 | 8 |
| 4 | 8 | 8 | 8 | 8 | 12 | 12 | 8 | 8 | 8 | 8 |
| 3 | 8 | 8 | 8 | 8 | 12 | 12 | 8 | 8 | 8 | 8 |
| 2 | 8 | 8 | 8 | 8 | 8 | 8 | 8 | 8 | 8 | 8 |
| 1 | 8 | 8 | 8 | 8 | 8 | 8 | 8 | 8 | 8 | 8 |

P6: Cardio 3

The Cardio 3 program is designed to maintain a high total demand with two-minutes with high resistance and low elevation and two minutes at medium resistance with higher elevation for a total four-minute core program. The prolonged exertion period takes advantage of the long term energy stores and total aerobic capability when associated with speeds that require a high sustained cardiovascular demand.

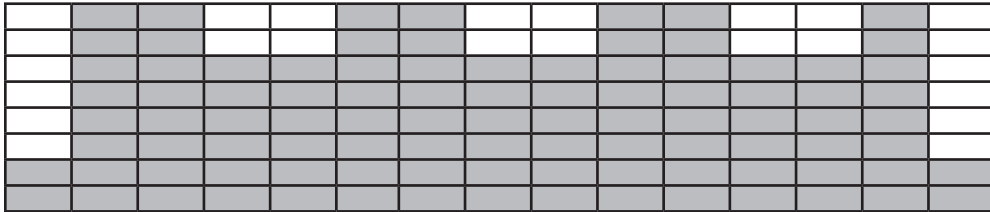

Resistance

| Time | :30 | :30 | :30 | :30 | 2:00 | 2:00 | :30 | :30 | :30 | :30 |
|------|---------|-----|-----|-----|------------------|------|-----------|-----|-----|-----|
| | Warm Up | | | | Program Segments | | Cool Down | | | |
| | 1 | 2 | 3 | 4 | 1 | 2 | 1 | 2 | 3 | 4 |
| 10 | 30 | 35 | 45 | 55 | 80 | 60 | 55 | 45 | 35 | 30 |
| 9 | 25 | 35 | 45 | 55 | 75 | 55 | 55 | 45 | 35 | 25 |
| 8 | 25 | 30 | 40 | 45 | 70 | 50 | 45 | 40 | 30 | 25 |
| 7 | 20 | 25 | 35 | 40 | 65 | 45 | 40 | 35 | 25 | 20 |
| 6 | 15 | 20 | 30 | 35 | 60 | 40 | 35 | 30 | 20 | 15 |
| 5 | 15 | 20 | 25 | 30 | 55 | 35 | 30 | 25 | 20 | 15 |
| 4 | 10 | 15 | 20 | 25 | 50 | 30 | 25 | 20 | 15 | 10 |
| 3 | 5 | 10 | 15 | 20 | 45 | 30 | 20 | 15 | 10 | 5 |
| 2 | 0 | 5 | 10 | 15 | 40 | 25 | 15 | 10 | 5 | 0 |
| 1 | 0 | 0 | 5 | 10 | 35 | 20 | 10 | 5 | 0 | 0 |

Elevation

| Time | :30 | :30 | :30 | :30 | 2:00 | 2:00 | :30 | :30 | :30 | :30 |
|------|---------|-----|-----|-----|------------------|------|-----------|-----|-----|-----|
| | Warm Up | | | | Program Segments | | Cool Down | | | |
| | 1 | 2 | 3 | 4 | 1 | 2 | 1 | 2 | 3 | 4 |
| 10 | 6 | 8 | 10 | 12 | 10 | 16 | 12 | 10 | 8 | 6 |
| 9 | 6 | 6 | 8 | 10 | 10 | 16 | 10 | 8 | 6 | 6 |
| 8 | 6 | 6 | 8 | 8 | 10 | 14 | 8 | 8 | 6 | 6 |
| 7 | 6 | 6 | 8 | 8 | 8 | 14 | 8 | 8 | 6 | 6 |
| 6 | 6 | 6 | 6 | 8 | 8 | 12 | 8 | 6 | 6 | 6 |
| 5 | 6 | 6 | 6 | 6 | 8 | 12 | 6 | 6 | 6 | 6 |
| 4 | 4 | 4 | 4 | 6 | 6 | 10 | 6 | 4 | 4 | 4 |
| 3 | 4 | 4 | 4 | 6 | 6 | 10 | 6 | 4 | 4 | 4 |
| 2 | 4 | 4 | 4 | 4 | 4 | 8 | 4 | 4 | 4 | 4 |
| 1 | 4 | 4 | 4 | 4 | 4 | 8 | 4 | 4 | 4 | 4 |

P7: Strength 1

The Strength 1 program uses a 1:2 work to rest ratio. It is designed for high resistance training with longer rest periods than the 1:1 program. Users will face a high level of resistance for thirty-seconds followed by a one minute recuperation period before performing the interval again. The elevation remains constant throughout the program.

| | | | | | | | | | | | | | | |
|--|--|--|--|--|--|--|--|--|--|--|--|--|--|--|
| | | | | | | | | | | | | | | |
| | | | | | | | | | | | | | | |
| | | | | | | | | | | | | | | |
| | | | | | | | | | | | | | | |
| | | | | | | | | | | | | | | |
| | | | | | | | | | | | | | | |
| | | | | | | | | | | | | | | |
| | | | | | | | | | | | | | | |
| | | | | | | | | | | | | | | |
| | | | | | | | | | | | | | | |

Resistance

| Time | :30 | :30 | :30 | :30 | :30 | :30 | :30 | :30 | :30 | :30 | :30 | :30 |
|-----------|----------------|----------|----------|----------|-------------------------|----------|----------|------------------|----------|----------|----------|-----|
| | Warm Up | | | | Program Segments | | | Cool Down | | | | |
| | 1 | 2 | 3 | 4 | 1 | 2 | 3 | 1 | 2 | 3 | 4 | |
| 10 | 35 | 45 | 55 | 65 | 70 | 45 | 45 | 40 | 35 | 30 | 20 | |
| 9 | 35 | 40 | 50 | 60 | 65 | 40 | 40 | 35 | 30 | 25 | 15 | |
| 8 | 30 | 40 | 50 | 55 | 60 | 35 | 35 | 30 | 25 | 20 | 15 | |
| 7 | 30 | 35 | 45 | 50 | 55 | 30 | 30 | 30 | 25 | 20 | 10 | |
| 6 | 25 | 35 | 40 | 45 | 50 | 30 | 30 | 30 | 25 | 20 | 10 | |
| 5 | 25 | 30 | 35 | 40 | 45 | 25 | 25 | 25 | 20 | 15 | 10 | |
| 4 | 20 | 25 | 30 | 35 | 40 | 25 | 25 | 25 | 20 | 15 | 10 | |
| 3 | 20 | 25 | 30 | 30 | 35 | 20 | 20 | 20 | 15 | 10 | 10 | |
| 2 | 15 | 20 | 25 | 30 | 30 | 20 | 20 | 20 | 15 | 10 | 5 | |
| 1 | 10 | 15 | 20 | 20 | 25 | 15 | 15 | 15 | 15 | 10 | 5 | |

Elevation

| Time | :30 | :30 | :30 | :30 | :30 | :30 | :30 | :30 | :30 | :30 | :30 | :30 |
|-----------|----------------|----------|----------|----------|-------------------------|----------|----------|------------------|----------|----------|----------|-----|
| | Warm Up | | | | Program Segments | | | Cool Down | | | | |
| | 1 | 2 | 3 | 4 | 1 | 2 | 3 | 1 | 2 | 3 | 4 | |
| 10 | 8 | 8 | 12 | 16 | 20 | 20 | 20 | 16 | 12 | 8 | 4 | |
| 9 | 8 | 8 | 12 | 16 | 20 | 20 | 20 | 16 | 12 | 8 | 4 | |
| 8 | 8 | 8 | 12 | 12 | 16 | 16 | 16 | 12 | 12 | 8 | 4 | |
| 7 | 8 | 8 | 12 | 12 | 16 | 16 | 16 | 12 | 12 | 8 | 4 | |
| 6 | 8 | 8 | 12 | 12 | 16 | 16 | 16 | 12 | 12 | 8 | 4 | |
| 5 | 8 | 8 | 8 | 12 | 12 | 12 | 12 | 12 | 8 | 8 | 4 | |
| 4 | 8 | 8 | 8 | 8 | 12 | 12 | 12 | 8 | 8 | 8 | 4 | |
| 3 | 8 | 8 | 8 | 8 | 12 | 12 | 12 | 8 | 8 | 8 | 4 | |
| 2 | 8 | 8 | 8 | 8 | 8 | 8 | 8 | 8 | 8 | 8 | 4 | |
| 1 | 8 | 8 | 8 | 8 | 8 | 8 | 8 | 8 | 8 | 8 | 4 | |

P8: Strength 2

The Strength 2 program is designed with the specific goal of raising the users' lactic acid threshold. The program uses a 1:3 work to rest ratio with fifteen-second intervals for maximum power development and forty-five second rest periods for recuperation.

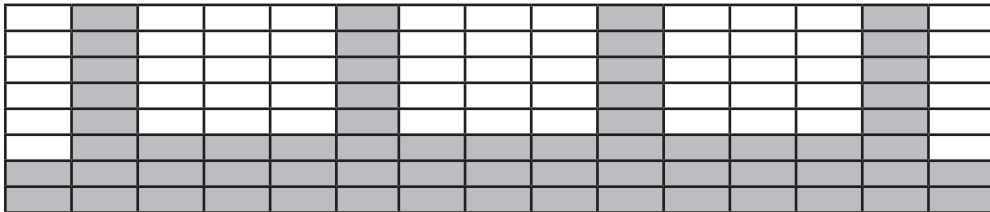

Resistance

| Time | :30 | :30 | :30 | :30 | :15 | :15 | :15 | :15 | :30 | :30 | :30 | :30 |
|------|---------|-----|-----|-----|------------------|-----|-----|-----|-----------|-----|-----|-----|
| | Warm Up | | | | Program Segments | | | | Cool Down | | | |
| | 1 | 2 | 3 | 4 | 1 | 2 | 3 | 4 | 1 | 2 | 3 | 4 |
| 10 | 25 | 30 | 40 | 45 | 100 | 35 | 35 | 35 | 30 | 25 | 20 | 15 |
| 9 | 25 | 30 | 35 | 40 | 95 | 35 | 35 | 35 | 30 | 25 | 20 | 15 |
| 8 | 25 | 30 | 35 | 40 | 90 | 35 | 35 | 35 | 30 | 25 | 20 | 15 |
| 7 | 25 | 30 | 35 | 40 | 85 | 30 | 30 | 30 | 25 | 20 | 20 | 15 |
| 6 | 20 | 25 | 30 | 35 | 80 | 30 | 30 | 30 | 25 | 20 | 20 | 15 |
| 5 | 20 | 25 | 30 | 35 | 75 | 30 | 30 | 30 | 25 | 20 | 15 | 10 |
| 4 | 20 | 5 | 30 | 35 | 70 | 25 | 25 | 25 | 20 | 20 | 0 | 0 |
| 3 | 20 | 20 | 25 | 30 | 65 | 25 | 25 | 25 | 20 | 20 | 0 | 0 |
| 2 | 15 | 20 | 25 | 30 | 60 | 20 | 20 | 20 | 15 | 0 | 10 | 5 |
| 1 | 15 | 15 | 20 | 25 | 55 | 20 | 20 | 20 | 15 | 0 | 10 | 5 |

Elevation

| Time | :30 | :30 | :30 | :30 | :15 | :15 | :15 | :15 | :30 | :30 | :30 | :30 |
|------|---------|-----|-----|-----|------------------|-----|-----|-----|-----------|-----|-----|-----|
| | Warm Up | | | | Program Segments | | | | Cool Down | | | |
| | 1 | 2 | 3 | 4 | 1 | 2 | 3 | 4 | 1 | 2 | 3 | 4 |
| 10 | 10 | 12 | 16 | 18 | 20 | 20 | 20 | 20 | 18 | 16 | 12 | 10 |
| 9 | 10 | 12 | 16 | 18 | 20 | 20 | 20 | 20 | 18 | 16 | 12 | 10 |
| 8 | 10 | 12 | 14 | 16 | 18 | 18 | 18 | 18 | 16 | 14 | 12 | 10 |
| 7 | 10 | 12 | 14 | 16 | 18 | 18 | 18 | 18 | 16 | 14 | 12 | 10 |
| 6 | 10 | 12 | 14 | 16 | 18 | 18 | 18 | 18 | 16 | 14 | 12 | 10 |
| 5 | 8 | 10 | 12 | 14 | 16 | 16 | 16 | 16 | 14 | 12 | 10 | 8 |
| 4 | 8 | 10 | 12 | 14 | 16 | 16 | 16 | 16 | 14 | 12 | 10 | 8 |
| 3 | 8 | 10 | 12 | 14 | 16 | 16 | 16 | 16 | 14 | 12 | 10 | 8 |
| 2 | 6 | 8 | 10 | 12 | 14 | 14 | 14 | 14 | 12 | 10 | 8 | 6 |
| 1 | 6 | 8 | 10 | 12 | 14 | 14 | 14 | 14 | 12 | 10 | 8 | 6 |

P9: Heartrate Control

The Heartrate Control (HRC) program will attempt to bring the user to their target heartrate in 3-5 minutes, then keep them there for the duration of the body of the program. A *Cool Down* is built in to the end of the program. HRC is run in Constant Power and thus defines watts.

The user selects a target heartrate, which defaults to 75% of max (max is 220-age). Limits should be set to not allow a Target HR (THR) less than 60% of max or more than 95% of max.

The protocol starts in Stage II, with the entry point based on Target HR.

- 80 – 120 BPM = Step 6
- 121-127 BPM = Step 8
- 128-134 BPM = Step 10
- 135-up BPM = Step 12

A running pulse-to-pulse BPM value is continuously measured.

Every 15 seconds the user's pulse rate is sampled and a prediction function is evaluated (decision.) This is subtracted from the target heartrate to form an error value which is scaled and added to the current load value. There is a maximum rate of change of 15 steps per decision.

The workload equates to the speed and incline load of the 750T Treadmill HRC Program. A chart of Step and Watts has been created. It has four defined stages:

- Stage 1 ramps the load from Step 1 to Step 5.
- Stage 2 ramps the load from Step 6 through Step 18.
- Stage 3 ramps the load from Step 19 through Step 39.
- Stage 4 ramps the load from Step 40 through Step 100.

The user has full control over incline throughout the program, with incline having no bearing on the program at all. The user has limited control over the load in that the user's selections are not permanent. At the next decision, a new load can be chosen by the software as described above to override any user modifications.

If the user presses the **LEVEL** key, they can modify their Target Heartrate real-time. Utilize the Target Heartrate Setup selection screen and exit back to the program in progress, making the change to their target heartrate real-time.

Lost Signal

If a signal is lost for two consecutive decisions (roughly 30 seconds), the display will beep four times, show 'HR SIGNAL LOST', show dashes in the BPM window and show the heart solid white. During this HR signal lost period, the load will remain steady.

If after two further decisions (roughly an additional 30 seconds) the heartrate signal has not been reestablished, continue to show 'HR SIGNAL LOST' on the Text area. The program will reduce the workload by 10 steps per minute until minimum workload or Step 1. After one minute at minimum workload, go to *Exiting Active Mode*.

Cool Down

By default, *Cool Down* occurs at session time minus two minutes or if the user presses the **Cool Down** button. *Cool Down* goes to 75% of existing step, then drops by 1 step every 15 seconds for the remainder of *Cool Down*.

| Stage 1 | | Stage 2 | | Stage 3 | | Stage 4 | |
|---------|-------|---------|-------|---------|-------|---------|-------|
| Step | Watts | Step | Watts | Step | Watts | Step | Watts |
| 1 | 25 | 6 | 50 | 19 | 115 | 40 | 220 |
| 2 | 30 | 7 | 55 | 20 | 120 | 41 | 225 |
| 3 | 35 | 8 | 60 | 21 | 125 | 42 | 230 |
| 4 | 40 | 9 | 65 | 22 | 130 | 43 | 235 |
| 5 | 45 | 10 | 70 | 23 | 135 | 44 | 240 |
| | | 11 | 75 | 24 | 140 | 45 | 245 |
| | | 12 | 80 | 25 | 145 | 46 | 250 |
| | | 13 | 85 | 26 | 150 | 47 | 255 |
| | | 14 | 90 | 27 | 155 | 48 | 260 |
| | | 15 | 95 | 28 | 160 | 49 | 265 |
| | | 16 | 100 | 29 | 165 | 50 | 270 |
| | | 17 | 105 | 30 | 170 | 51 | 275 |
| | | 18 | 110 | 31 | 175 | 52 | 280 |
| | | | | 32 | 180 | 53 | 285 |
| | | | | 33 | 185 | 54 | 290 |
| | | | | 34 | 190 | 55 | 295 |
| | | | | 35 | 195 | 56 | 300 |
| | | | | 36 | 200 | 57 | 305 |
| | | | | 37 | 205 | 58 | 310 |
| | | | | 38 | 210 | 59 | 315 |
| | | | | 39 | 215 | 60 | 320 |
| | | | | | | 61 | 325 |
| | | | | | | 62 | 330 |
| | | | | | | 63 | 335 |
| | | | | | | 64 | 340 |
| | | | | | | 65 | 345 |
| | | | | | | 66 | 350 |
| | | | | | | 67 | 355 |
| | | | | | | 68 | 360 |
| | | | | | | 69 | 365 |
| | | | | | | 70 | 370 |
| | | | | | | 71 | 375 |
| | | | | | | 72 | 380 |
| | | | | | | 73 | 385 |
| | | | | | | 74 | 390 |

| Stage 1 | | Stage 2 | | Stage 3 | | Stage 4 | |
|---------|-------|---------|-------|---------|-------|---------|-------|
| Step | Watts | Step | Watts | Step | Watts | Step | Watts |
| | | | | | | 75 | 395 |
| | | | | | | 76 | 400 |
| | | | | | | 77 | 405 |
| | | | | | | 78 | 410 |
| | | | | | | 79 | 415 |
| | | | | | | 80 | 420 |
| | | | | | | 81 | 425 |
| | | | | | | 82 | 430 |
| | | | | | | 83 | 435 |
| | | | | | | 84 | 440 |
| | | | | | | 85 | 445 |
| | | | | | | 86 | 450 |
| | | | | | | 87 | 455 |
| | | | | | | 88 | 460 |
| | | | | | | 89 | 465 |
| | | | | | | 90 | 470 |
| | | | | | | 91 | 475 |
| | | | | | | 92 | 480 |
| | | | | | | 93 | 485 |
| | | | | | | 94 | 490 |
| | | | | | | 95 | 495 |
| | | | | | | 96 | 500 |
| | | | | | | 97 | 505 |
| | | | | | | 98 | 510 |
| | | | | | | 99 | 515 |
| | | | | | | 100 | 520 |



10 Trotter Drive Medway, MA 02053 • 508-533-4300 • FAX 508-533-5183
www.cybexintl.com • techhelp@cybexintl.com