

# Jungle Gym Half Weight Kit

Kit No. 17030K003  
17050K003

Installation Instructions

## TOOLS REQUIRED

- 9/16 Wrench
- 7/32 Allen wrench

Read and understand all instructions thoroughly before installing this kit.

### Verify 17030K003 kit contents

- C/Half Weight 3 x 12 (1), 17001-340
- Half Weight Bracket (1), 17030-205
- Locknut .375-16 Nylon (2), HN704901
- BHSCS .375-16 x 3.50 (2), JC700438

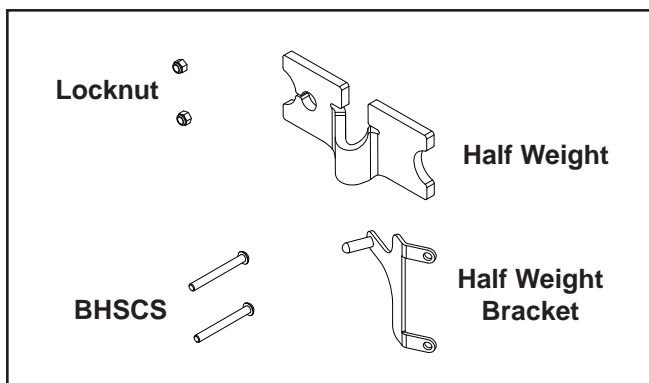

### Verify 17050K003 kit contents

- C/Half Weight 3 x 12 (1), 17001-340
- Half Weight Mount (1), 17000-205
- Locknut .375-16 Nylon (2), HN704901

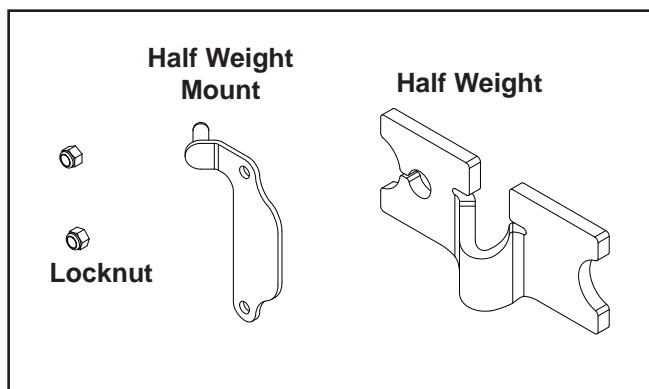

### Installing 17030K003 kit

1. Using a 9/16 wrench and a 7/32 Allen wrench remove the two Button Head Socket Cap Screw (BHSCS), plate, and locknuts.

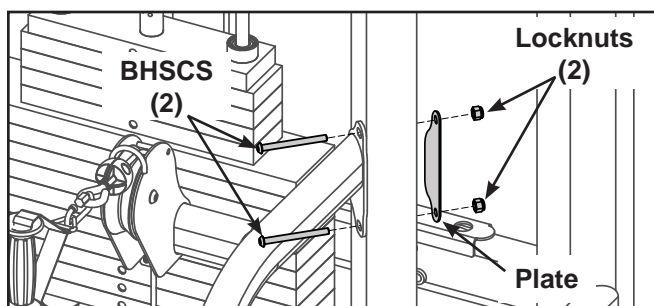

2. Install the new two BHSCS, half weight bracket, locknuts from kit and reattach plate.

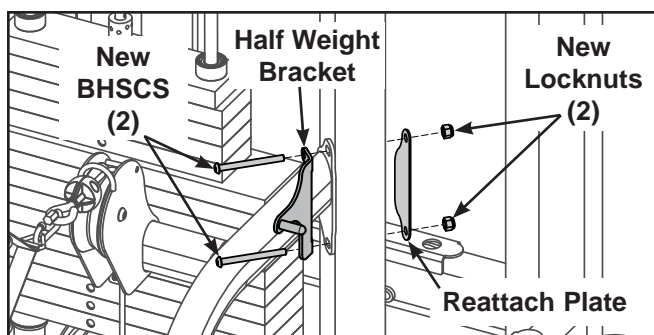

3. Using a 9/16 wrench and a 7/32 Allen wrench securely tighten the BHSCS and locknut.

### Installing 17050K003 kit

1. Using a 9/16 wrench and a 7/32 Allen wrench remove the two BHSCS, plates and locknuts.

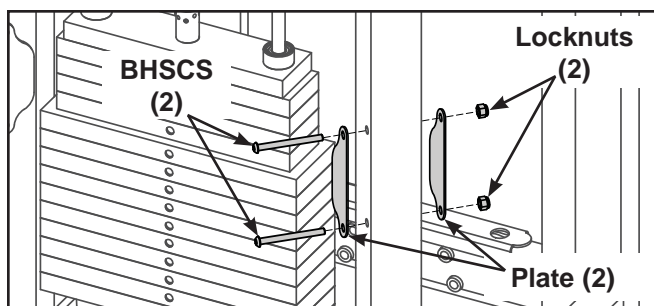

2. Discard front plate and two lock nuts.
3. Install half weight bracket and back plate with two BHSCS and new locknuts.

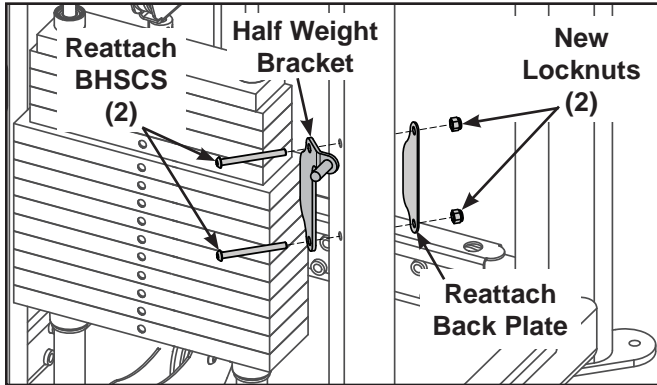

4. Using a 9/16 wrench and a 7/32 Allen wrench securely tighten the BHSCS and locknuts.