

# Eagle® Back Extension Adjusting Foot Rest with Decal

Product No. 11100K005

Installation Instructions

## TOOLS REQUIRED

- 7/32" Allen wrench
- 1/2" Wrench (2)

1. Read and understand all instructions thoroughly before installing this kit.

2. Verify kit contents. See Figure 1.

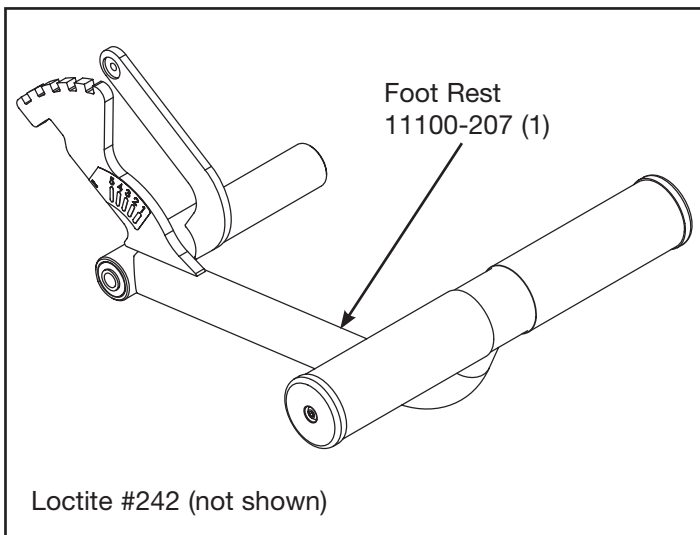

Figure 1

3. Replace existing foot rest.

A. Remove the ball stud and nut connecting the foot rest to the gas spring. See Figure 2.

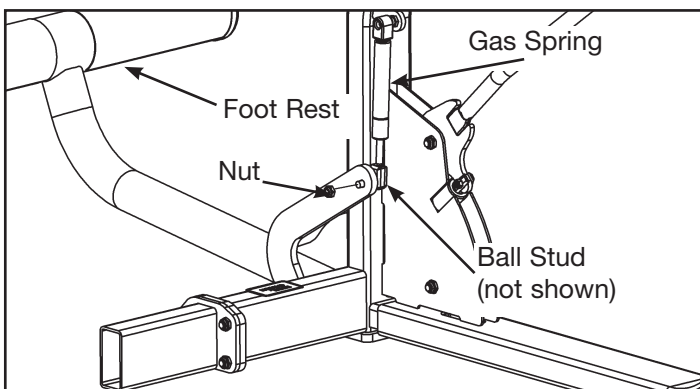

Figure 2

B. Remove one of the BHSCS and washer securing pivot shaft and remove pivot shaft. See Figure 3.

C. Remove foot rest from machine. See Figure 3.

D. Slide new foot rest into place.

E. Slide pivot shaft back into place (removed in step 3B).

F. Align detent pin.

G. Place loctite #242 onto the BHSCS and also on the threads where the screw was removed in step 3B. Secure the pivot shaft (removed in step 3B) using the BHSCS and washer.

H. Secure the foot rest to the gas spring with the ball stud and nut removed in step 3A.

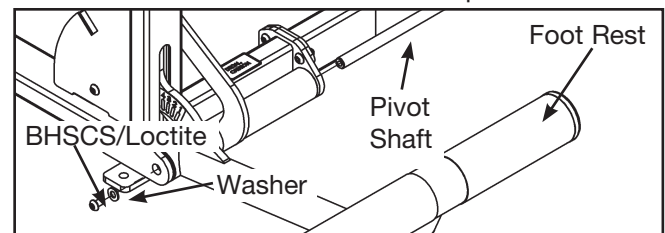

Figure 3

I. Test for proper operation.



Cybex® and the Cybex logo are registered trademarks of Cybex International, Inc.

Eagle® and its mark are registered trademarks of Cybex International, Inc.

10 Trotter Drive Medway, MA 02053 • 508-533-4300 • FAX 508-533-5183 • www.cybexinternational.com • techhelp@cybexintl.com  
techpubs@cybexintl.com • Copyright © 2004, Cybex International, Inc. All rights reserved • 11100-401 • October 2004