

Apple iPod, iPhone Upgrade Kit

Kit Number 626AK011

Installation Instructions

This instruction sheet describes how to install the Apple upgrade kit for Cybex Arc models 626A, 626AT, 627A, and 627AT.

Tools Required

- Phillips screwdriver
- Utility knife
- ESD (Electrostatic Discharge) grounding strap

Read and understand all instructions thoroughly before installing this kit.

Verify the kit contents shown.

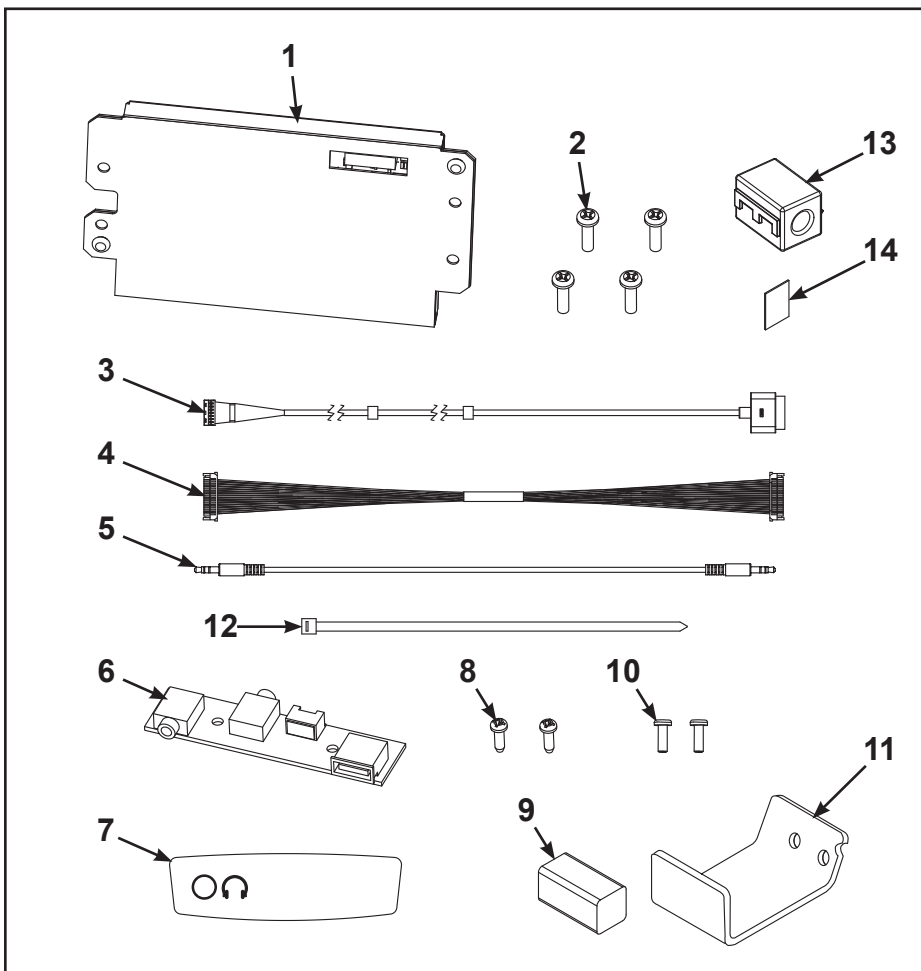

	Description	Qty.
1	iPod assembly	1
2	Screw, 6-19 x 0.50"	4
3	Cable, iPod	1
4	Cable, GFX to MCC	1
5	Cable, Headphone jack jumper	1
6	PCA, Headphone jack board	1
7	Headphone jack decal	1
8	Screw, 4 x 3/8	2
9	Gasket	1
10	Screw, #8-32 x 0.50"	2
11	Grounding bracket	1
12	Cable tie	1
13	Ferrite	1
14	Tape	1

Disconnect optional external power source

Unplug the unit from the power outlet.



WARNING: Shock and electrocution hazard

- Unplug unit and let sit 10 minutes before cleaning or performing maintenance
- Electrical charge can remain in unit after unplugging
- Keep water and liquids away from electrical parts

NOTICE: Component damage

Wear an ESD grounding strap during this procedure. Connect ESD grounding strap to frame bolts or unpainted metal of frame. If ESD grounding strap is not available, touch frame bolts or unpainted metal of frame before handling any electronics.

Remove back cover

Remove the four screws securing the back cover to the console assembly using a Phillips screwdriver.

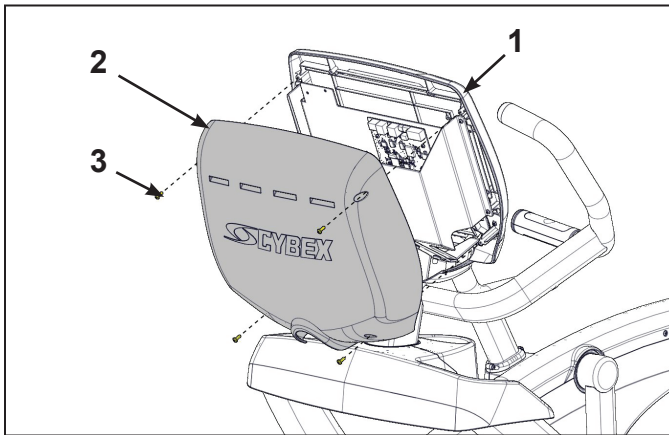

	Description	Qty
1	Console assembly	1
2	Back cover	1
3	Screws	4

Remove console assembly

1. Remove the six screws securing the console assembly to the console support using a Phillips screwdriver.

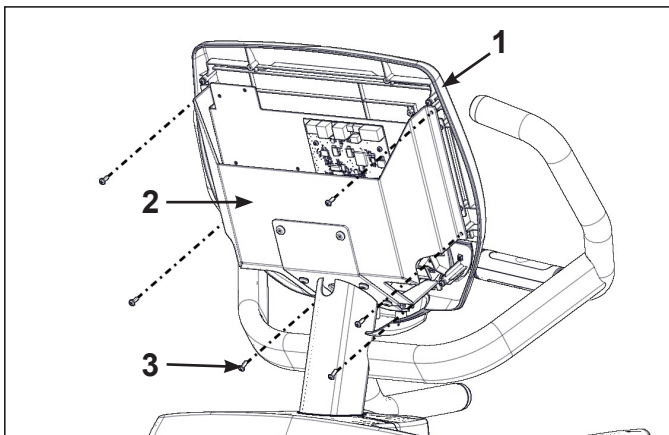

	Description	Qty
1	Console assembly	1
2	Console support	1
3	Screws	6

- Unplug cables by pinching latch and make sure it releases connector. Pull connector out.

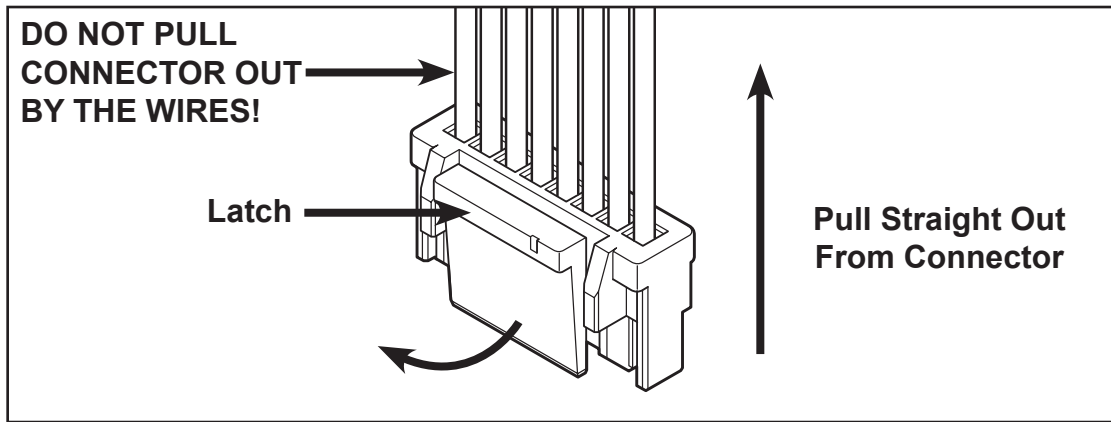

Install headphone jack board

- Remove the blank decal from the headphone jack cover using a utility knife.

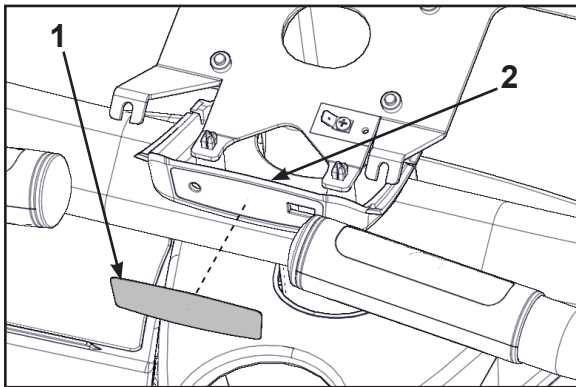

	Description	Qty
1	Blank decal	1
2	Headphone jack cover	1

- Install the two 4 x 3/8" screws securing the headphone jack board to the headphone jack cover using a Phillips screwdriver.

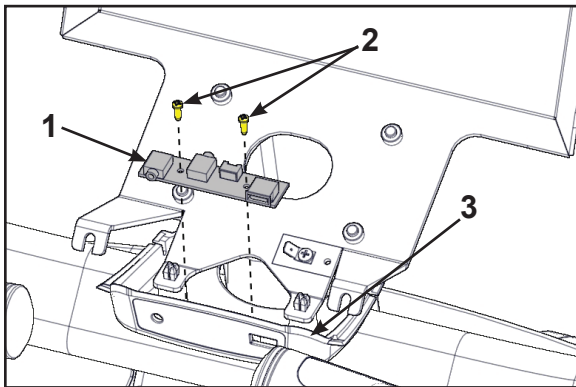

	Description	Qty
1	Headphone jack board	1
2	Screws, 4 x 3/8"	2
3	Headphone jack cover	1

3. Install the headphone jack decal to the headphone jack cover.

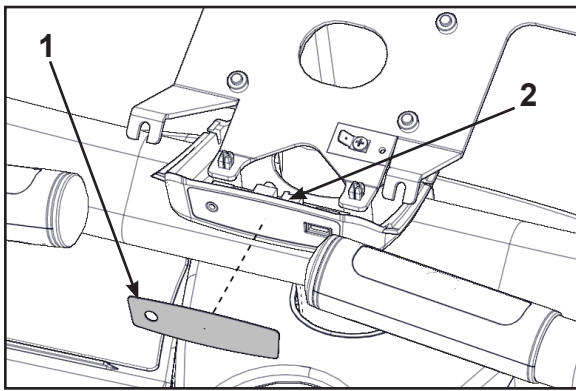

	Description	Qty
1	Headphone jack decal	1
2	Headphone jack cover	1

4. Plug the headphone jack cable into the headphone jack board.

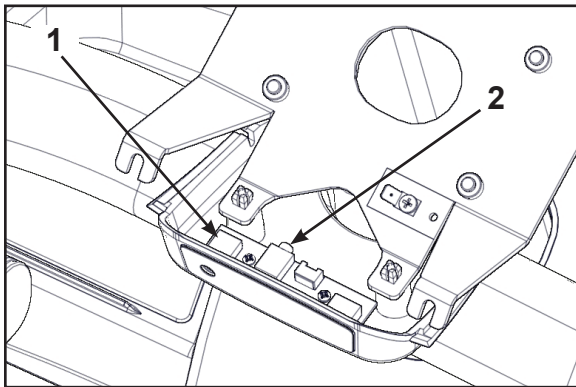

	Description	Qty
1	Headphone jack board	1
2	Plug cable in here	1

Install grounding bracket

1. Remove the grounding tab and screw using a Phillips screwdriver.

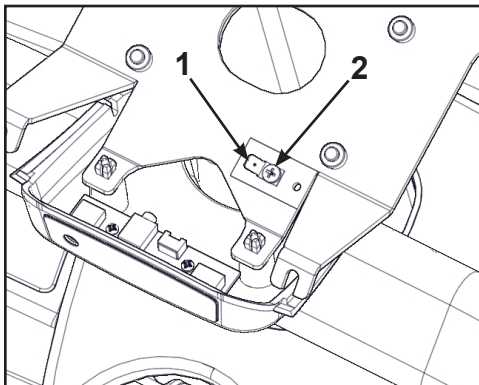

	Description	Qty
1	Grounding tab	1
2	Screw	1

2. Remove the backing from the gasket and apply to the grounding bracket.

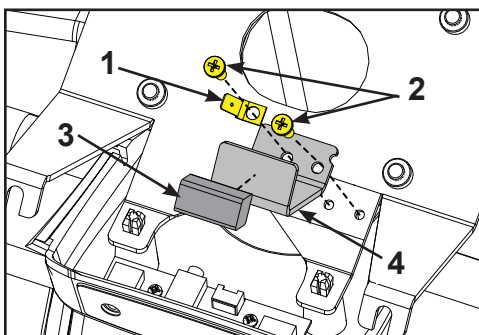

	Description	Qty
1	Grounding tab	1
2	Screws, 8-32 x 0.50"	2
3	Gasket	1
4	Grounding bracket	1

3. Install the grounding bracket, grounding tab, and 8-32 x 0.50" screws to the console as shown using a Phillips screwdriver.

Install iPod board

1. Remove the screw securing the clamp as shown using a Phillips screwdriver.

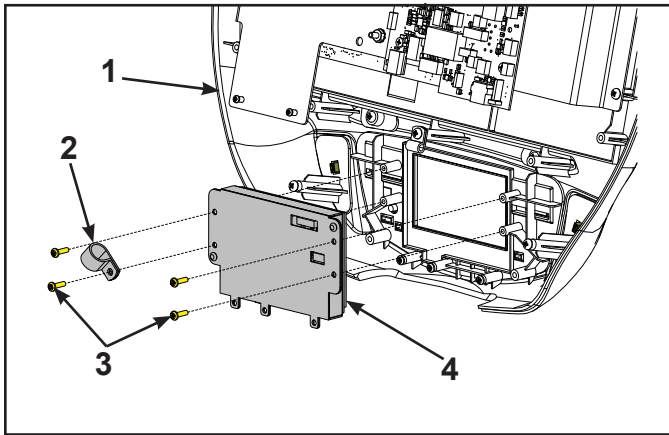

	Description	Qty
1	Console front	1
2	Clamp	1
3	Screws	4
4	iPod board	1

2. Install the iPod board, four screws, and clamp as shown using a Phillips screwdriver.
3. Plug the GFX to MCC cable into the iPod board.
4. Attach ferrite to GFX to MCC cable. Tape ferrite to back of iPod board.

Connect console cables

Install console cables to MCC board.

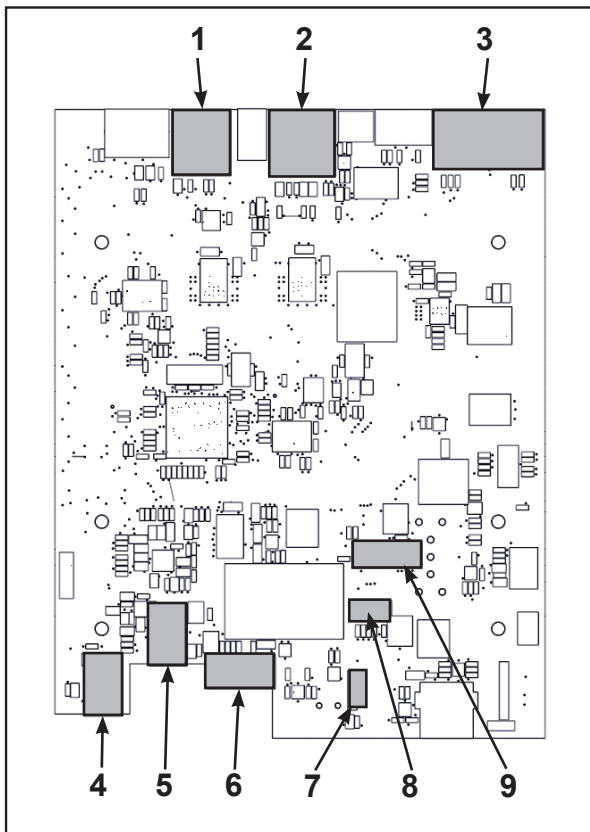

	Description
1	CSAFE (optional)
2	Display
3	E3 View monitor
4	A/V
5	Headphone jack
6	iPod
7	Heart rate
8	Handset membrane
9	iPod board assembly

Install console assembly

Install the six screws securing the console assembly to the console support using a Phillips screwdriver.

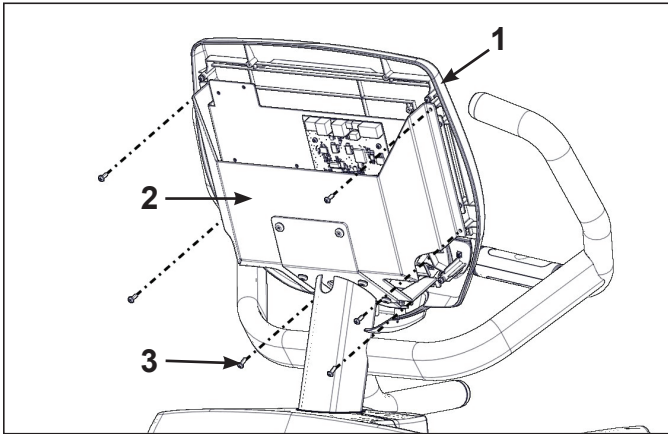

	Description	Qty
1	Console assembly	1
2	Console support	1
3	Screws	6

Route iPod cable

1. Remove three screws securing accessory tray bottom to the accessory tray base using a Phillips screwdriver.

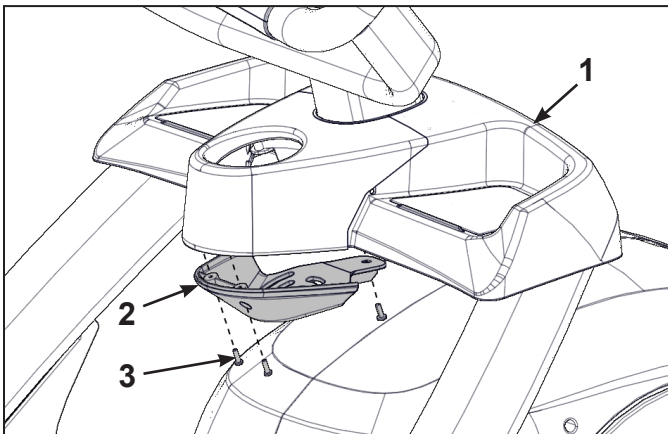

	Description	Qty
1	Accessory tray base	1
2	Accessory tray bottom	1
3	Screws	3

2. Remove two screws securing accessory tray top to accessory tray base using a Phillips screwdriver.

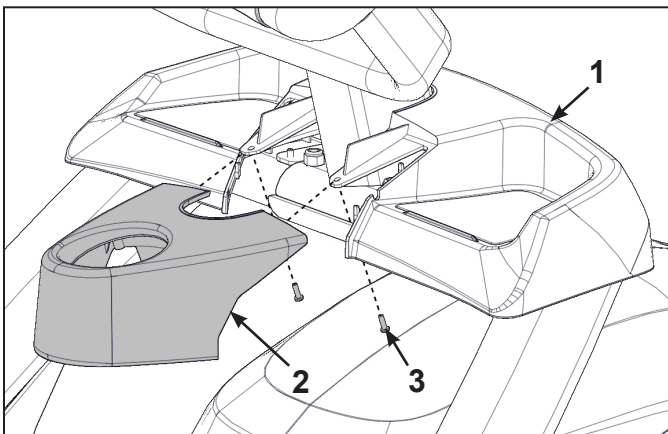

	Description	Qty
1	Accessory tray base	1
2	Accessory tray top	1
3	Screws	2

3. Remove four screws securing accessory tray base to frame using a Phillips screwdriver.

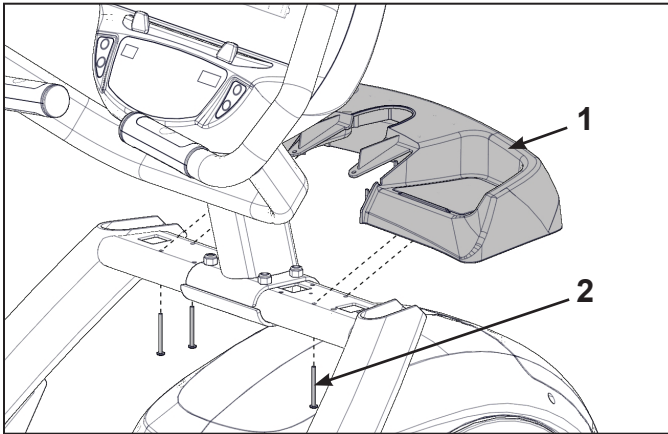

	Description	Qty
1	Accessory tray base	1
2	Screws	4

4. Secure iPod cable to console weldment using cable tie.

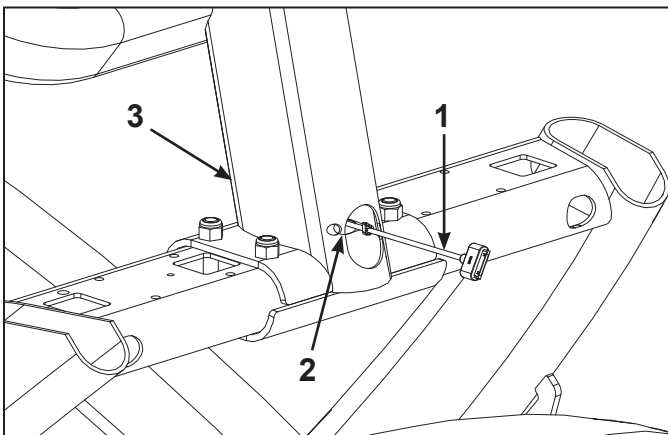

	Description	Qty
1	Cable, iPod	1
2	Cable tie	1
3	Console weldment	1

5. Place the accessory tray in position on the frame and route the iPod cable towards the back of the unit.

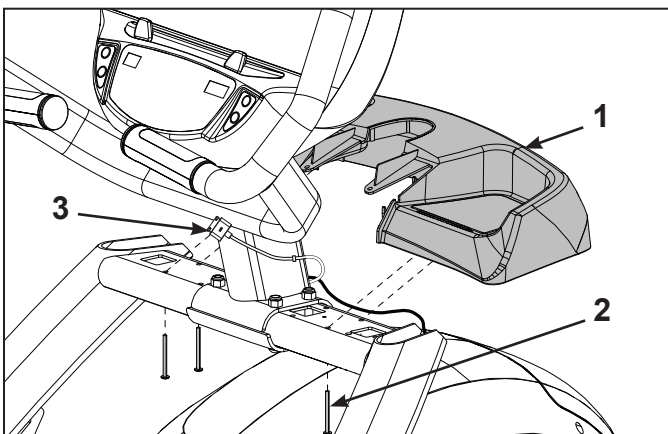

	Description	Qty
1	Accessory tray base	1
2	Screws	4
3	Cable, iPod	1

6. Install four screws securing accessory tray base to frame using a Phillips screwdriver.

7. Place the accessory tray top in position on the accessory tray base and route the iPod cable through the notch in the accessory tray. Place the iPod cable strain relief on the inside edge of the notch in the accessory tray.

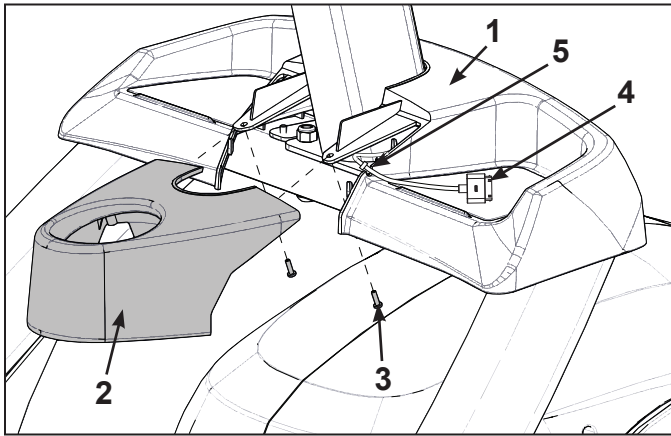

	Description	Qty
1	Accessory tray base	1
2	Accessory tray top	1
3	Screws	2
4	Cable, iPod	1
5	Notch	1

8. Install two screws securing accessory tray top to accessory tray base using a Phillips screwdriver.
9. Install three screws securing accessory tray bottom to the accessory tray base using a Phillips screwdriver.

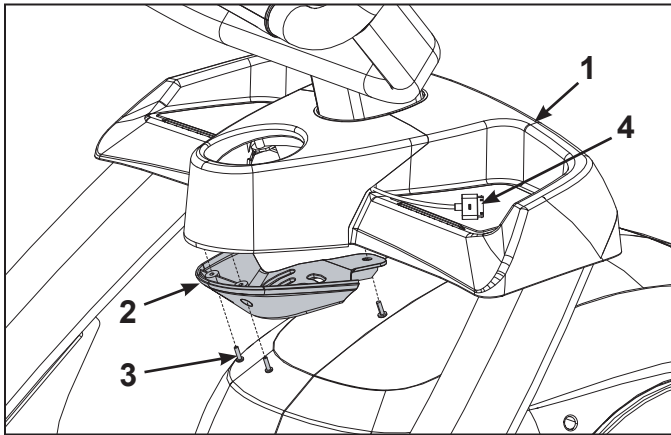

	Description	Qty
1	Accessory tray base	1
2	Accessory tray bottom	1
3	Screws	3
4	Cable, iPod	1

Install back cover

Install the four screws securing the back cover to the console assembly using a Phillips screwdriver.

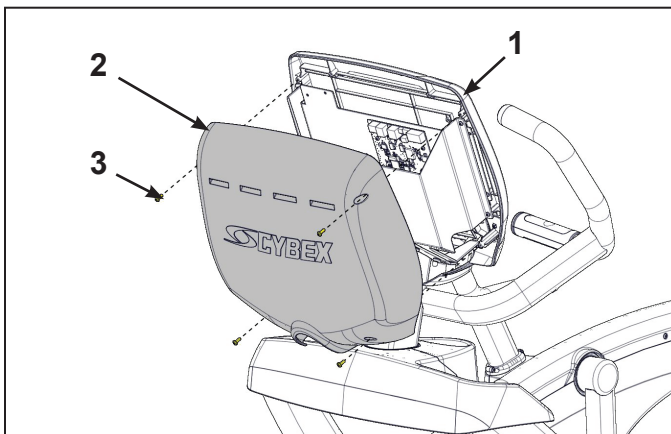

	Description	Qty
1	Console assembly	1
2	Back cover	1
3	Screws	4

Complete installation

1. Plug the optional power cord into the power inlet.
2. Begin striding the unit until the console lights up.
3. Operate the unit at all levels to verify proper operation.

Cybox® and the Cybox logo are registered trademarks of Cybox International, Inc.
iPod and iPhone are trademarks of Apple Inc., registered in the U.S. and other countries.
10 Trotter Drive Medway, MA 02053
508-533-4300 • FAX 508-533-5183 • www.cyboxintl.com
Copyright © 2014, Cybox International, Inc. All rights reserved • 626A-322 • September 2014

