

Running Belt Maintenance

Belt and Deck — Wipe the belt surface and the deck area with a clean dry towel to minimize the effect of friction between the deck and the running belt. This should be done often to prevent premature wear of the deck, running belt, and the drive motor system. See the *Service Schedule* at the end of this chapter.

The running belt may become loose and slip on the drive roller with each foot plant. If it does, follow the *Tensioning and Centering the Belt* procedure below. See the *Service Schedule* in this chapter for a minimum schedule for checking the belt tension.

Tension and Center the Belt — If the belt is slipping under each step perform this procedure:

Tools Required

- 3/4" Socket wrench

1. Tension the belt.

A. Use a 3/4" socket wrench to turn each bolt 1/2 turn clockwise. See Figure 1.

NOTE: Be sure to adjust each bolt equally on each side.

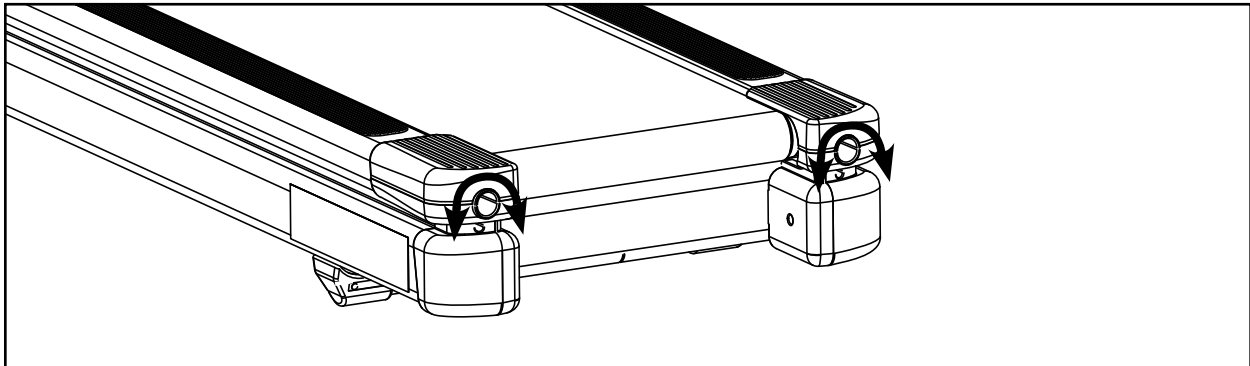

Figure 1

B. Press the **Quick Start** key.

C. Press the **Speed +** to bring the speed up to 3.5-4 mph (5.6-6.4 kph). Allow the treadmill to run for a minute.

D. Observe the belt to be sure it stays centered. If it is not centered follow step 2.

E. Walk on the belt to see if it still slips. If it does restart this procedure at step 1 A. If you have to do this procedure three times and it still slips call Cybex Customer Service. Follow the next step to be sure the belt is centered.

NOTE: Be careful not to over tighten the belt. Over tightening the belt can cause the belt to stretch and require replacement.

2. Center the belt.

NOTE: While centering the belt choose one bolt to adjust. Do not adjust both bolts.

- A. With the treadmill running at 5 mph (8 kph) observe the running belt. If the belt tracks off center to the right or left the deck will become exposed. Use a 3/4" socket wrench to tighten the rear roller bolt on the side of the treadmill toward which the belt is moving. For example: If the belt moves to the right and the deck becomes exposed on the left, tighten the bolt on the right side of the frame, tighten about 1/2 of a turn (clockwise) and wait 30 seconds. If the belt does not move back to the center of the treadmill, make another adjustment to the **same bolt**. Once the running belt has been adjusted closer to the center of the treadmill use about 1/4 of a turn until the belt has been stabilized.
- B. After the belt has been centered, check the belt tension again. Make sure the running belt tension is tight enough so that the belt does not slip or hesitate when stepped on. Walk on the treadmill at 3.5-4 mph (5.6-6.4 kph) and every 4th to 5th step throw your weight into your step to feel if the belt is slipping. If the belt does slip, use a wrench to equally tighten **both** rear roller adjustment bolts 1/2 of a turn (clockwise). Adjust the belt until no further slipping is felt.

Checking the Belt and Deck Surfaces — The running belt and deck should be checked periodically for any excessive wear. In an effort to make sure that the running belt operates properly, visually inspect the belt often to make sure that there are no tears or fraying in the belt material. The running belt, deck, deck bushings and motor brushes should be replaced every 12,000 miles (19,300 km). A service prompt will appear at this interval and the parts will need to be replaced.

Inspect the edges of the belt as described below.

Tools Required

- None

1. Disconnect the external power source.

- A. Turn the main power switch on the right side to the off (O) position.
- B. Unplug the treadmill from the power outlet.

2. Check the belt and deck condition.

- A. Look at the edges of the belt while you roll it by hand. If the belt has any rips or looks excessively worn the belt needs to be replaced.
- B. Run your hand under the belt on the top of the deck surface. If you feel excessive ridges or cracks, the deck should be replaced. In time, a worn belt and deck can cause high current draw and ultimately, motor failure.

NOTE: If the running belt and deck need replacement refer to a qualified service technician.