

# Ion Series Smith Rack

Owner's Manual

CI-SM

---



Part Number  
1015904-0001 AA

**CYBEX**<sup>®</sup>



# Corporate Headquarters

Columbia Centre III, 9525 West Bryn Mawr Avenue, Rosemont, Illinois 60018 • U.S.A.

847.288.3300 • FAX: 847.288.3703

Service phone number: 800.351.3737 (toll-free within U.S.A., Canada)

Global Website: [www.lifefitness.com](http://www.lifefitness.com)

## International Offices

### AMERICAS

#### North America

##### Life Fitness, Inc.

Columbia Centre III  
9525 West Bryn Mawr Avenue  
Rosemont, IL 60018 U.S.A.  
Telephone: (847) 288 3300  
Service Email: [customersupport@lifefitness.com](mailto:customersupport@lifefitness.com)  
Sales/Marketing Email:  
[commercialsales@lifefitness.com](mailto:commercialsales@lifefitness.com)

#### Brazil

##### Life Fitness Brasil

Av. Rebouças, 2315  
Pinheiros  
São Paulo, SP 05401-300  
BRAZIL  
SAC: 0800 773 8282 option 2  
Telephone: +55 (11) 3095 5200 option 2  
Service Email: [suportebr@lifefitness.com](mailto:suportebr@lifefitness.com)  
Sales/Marketing Email: [vendasbr@lifefitness.com](mailto:vendasbr@lifefitness.com)

#### Latin America and Caribbean\*

##### Life Fitness, Inc.

Columbia Centre III  
9525 West Bryn Mawr Avenue  
Rosemont, IL 60018 U.S.A.  
Telephone: (847) 288 3300  
Service Email: [customersupport@lifefitness.com](mailto:customersupport@lifefitness.com)  
Sales/Marketing Email:  
[commercialsales@lifefitness.com](mailto:commercialsales@lifefitness.com)

#### EUROPE, MIDDLE EAST, and AFRICA (EMEA)

#### Netherlands and Luxemburg

##### Life Fitness Atlantic BV

Bijdorplein 25-31  
2992 LB Barendrecht  
THE NETHERLANDS  
Telephone: (+31) 180 646 666  
Service Email: [service.benelux@lifefitness.com](mailto:service.benelux@lifefitness.com)  
Sales/Marketing Email:  
[marketing.benelux@lifefitness.com](mailto:marketing.benelux@lifefitness.com)

#### United Kingdom

##### Life Fitness UK LTD

Queen Adelaide  
Ely, Cambs, CB7 4UB  
Telephone: General Office (+44) 1353.666017  
Customer Support (+44) 1353.665507  
Service Email: [uk.support@lifefitness.com](mailto:uk.support@lifefitness.com)  
Sales/Marketing Email: [life@lifefitness.com](mailto:life@lifefitness.com)

#### Germany, Austria, and Switzerland

##### Life Fitness Europe GMBH

Neuhofweg 9  
85716 Unterschleißheim  
GERMANY  
Telephone:  
+49 (0) 89 / 31775166 Germany  
+43 (0) 1 / 6157198 Austria  
+41 (0) 848 / 000901 Switzerland  
Service Email: [kundendienst@lifefitness.com](mailto:kundendienst@lifefitness.com)  
Sales/Marketing Email: [vertrieb@lifefitness.com](mailto:vertrieb@lifefitness.com)

#### Spain

##### Life Fitness IBERIA

C/Frederic Mompou 5,1ª1ª  
08960 Sant Just Desvern Barcelona  
SPAIN  
Telephone: (+34) 93.672.4660  
Service Email: [servicio.tecnico@lifefitness.com](mailto:servicio.tecnico@lifefitness.com)  
Sales/Marketing Email:  
[info.iberia@lifefitness.com](mailto:info.iberia@lifefitness.com)

#### Belgium

##### Life Fitness Benelux NV

Parc Industriel de Petit-Rechain  
4800 Verviers  
BELGIUM  
Telephone: (+32) 87 300 942  
Service Email: [service.benelux@lifefitness.com](mailto:service.benelux@lifefitness.com)  
Sales/Marketing Email:  
[marketing.benelux@lifefitness.com](mailto:marketing.benelux@lifefitness.com)

#### All Other EMEA Countries and Distributor Business EMEA\*

Bijdorplein 25-31  
2992 LB Barendrecht  
THE NETHERLANDS  
Telephone: (+31) 180 646 644  
Service Email:  
[EMEAServiceSupport@lifefitness.com](mailto:EMEAServiceSupport@lifefitness.com)

#### ASIA PACIFIC (AP)

#### Japan

##### Life Fitness Japan, Ltd

4-17-33 Minami Aoyama 1F/B1F  
Minato-ku - Tokyo 107-0062  
Japan  
Telephone: (+81) 0120.114.482  
Fax: (+81) 03-5770-5059  
Service Email: [service.lfj@lifefitness.com](mailto:service.lfj@lifefitness.com)  
Sales/Marketing Email:  
[sales@lifefitnessjapan.com](mailto:sales@lifefitnessjapan.com)

#### Hong Kong

##### Life Fitness Asia Pacific LTD

32/F, Global Trade Square  
21 Wong Chuk Hang Road  
Hong Kong  
Telephone: (+852) 2575.6262  
Service Email: [Service.HK@lifefitness.com](mailto:Service.HK@lifefitness.com)  
Sales/Marketing Email:  
[hongkong.sales@lifefitness.com](mailto:hongkong.sales@lifefitness.com)

#### All Other Asia Pacific countries and distributor business Asia Pacific\*

32/F, Global Trade Square  
21 Wong Chuk Hang Road  
Hong Kong  
Telephone: (+852) 2575.6262  
Fax: (+852) 2575.6894  
Service Email: [Service.AP@lifefitness.com](mailto:Service.AP@lifefitness.com)  
Sales/Marketing Email:  
[Marketing.HK.Asia@lifefitness.com](mailto:Marketing.HK.Asia@lifefitness.com)

\*Also check [www.lifefitness.com](http://www.lifefitness.com) for local representation or distributor/dealer

# User and Service Documents Link

---

<https://www.lftechsupport.com/web/document-library/documents>

Additional information is available online using the link above.

تتوفر معلومات إضافية على الإنترنت باستخدام الرابط أعلاه.

点击上面的链接可在线获取更多信息。

Flere oplysninger er tilgængelige online gennem linket ovenfor.

Bijkomende informatie is online beschikbaar via bovenstaande link.

Vous trouverez plus d'informations en ligne à l'aide du lien ci-dessus.

Zusätzliche Informationen finden Sie online über den oben angegebenen Link.

Ulteriori informazioni sono disponibili online utilizzando il link sopra riportato.

追加情報は上記リンクを使用してオンラインで利用可能です。

상기 링크를 통해 온라인에서 추가 정보를 볼 수 있습니다.

Informações adicionais estão disponíveis on-line, através do link acima.

Дополнительная информация доступна в интернете по ссылке, указанной выше.

Mediante el enlace anterior podrá acceder a información adicional en línea.

Ytterligare information finns online genom att använda länken ovan.

İnternet üzerinden daha fazla bilgi edinmek için yukarıdaki bağlantıyı kullanabilirsiniz.

هناك معلومات إضافية متاحة على الإنترنت باستخدام الرابط أعلاه.

Informazio osagarria eskuragarri dago goiko estekaren bidez.

Допълнителна информация можете да намерите онлайн, като използвате връзката по-горе.

Mitjançant l'enllaç anterior podreu accedir a informació addicional en línia.

使用上面的連結線上提供額外資訊。

Dodatne informacije možete pronaći na internetu sljedeći vezu iznad.

ከላይ የተቀመጠውን አገናኝ(ሊንክ) በመጠቀም መረጃዎች አንላይን ያገኛሉ።

Lisätietoja on saatavissa verkosta käyttämällä yllä olevaa linkkiä.

Wubetumi anya nsem afororo aka ho wa websait so denam asem a ewo atifi ho a wubemia so so.

Πρόσθετες πληροφορίες είναι διαθέσιμες online χρησιμοποιώντας το σύνδεσμο παραπάνω.

מדעם ערעונו אשפא לבקל בארצות הברית ורשקו לעיל.

További információ elérhető online, a fenti hivatkozás segítségével.

Viðbótarupplýsingar eru fáanlegar á netinu með því að smella á tengilinn hér fyrir ofan.

Plus indicium per superum situm potes invenire.

മുകളിലുള്ള ലിങ്ക് ഉപയോഗിച്ച് ഓൺലൈനിൽ കൂടുതൽ വിവരങ്ങൾ ലഭ്യമാണ്.

Ytterligere informasjon er tilgjengelig på nettet via linken ovenfor.

Dodatkowe informacje są dostępne online pod powyższym odnośnikiem.

Informações adicionais estão disponíveis online a usar o link acima.

Informații suplimentare sunt disponibile online, utilizând link-ul de mai sus.

Dodatne informacije dostupne su na mreži putem gornjeg linka.

Ďalšie informácie sú dostupné online na vyššie uvedenom odkaze.

# Table of Contents

## Safety

Safety Information.....	4
Product Labels.....	6
Label Locations.....	7

## Assembly

Component and Hardware List.....	8
Tools Required.....	9
Assembly Procedure.....	9

## Product Information

Specifications.....	16
---------------------	----

## Exercise

General Exercise Information.....	17
Performing the Exercises.....	17

## Maintenance Procedures

Maintenance Schedule.....	19
---------------------------	----

## Warranty

What is Covered.....	21
Who is Covered.....	21
Who Pays Transportation and Insurance For Service.....	21
What We Will Do To Correct Covered Defects.....	21
What is Not Covered.....	21
Owner's Manual.....	21
Exclusive Warranty.....	21
Changes in Warranty Not Authorized.....	21
Effects of State Laws.....	21
Warranty Coverage.....	22

## Bolt to Floor Guide

Introduction.....	23
Delivery and Installation Tips.....	23
Anchor Types.....	24
Anchor Specifications.....	24
Pullout Force.....	24
Tools Required.....	24
Static Anchor Procedure.....	25
Foot Dimensions.....	26

Life Fitness® is a registered trademark.

Gym Wipes® is a registered trademark of the 2XL Corporation. PureGreen 24 is a trademark of Pure Green.

© Copyright 2020, Life Fitness, LLC. All Rights Reserved. Life Fitness, Hammer Strength, Cybex, ICG and SCIFIT are registered trademarks of Life Fitness, LLC and its affiliated companies and subsidiaries. Brunswick and related trademarks used under license from Brunswick Corporation. Disclaimer: Images and specifications are current as of the date of publication and are subject to change.

Columbia Center III - 9525 West Bryn Mawr Ave, Rosemont, IL 60018 • 800-351-3737 • 847-288-3700 • FAX 800-216-8893

[www.cybexintl.com](http://www.cybexintl.com) • 1015904-0001 AA • 2020

# Safety

---

## Safety Information

---

It is the sole responsibility of the purchaser of Life Fitness Family of Brands products to read the owner's manual and warning labels and instruct all individuals, whether they are the end user or supervising personnel, on proper usage of the equipment.

UNDERSTANDING EACH AND EVERY WARNING TO THE FULLEST IS IMPORTANT. IF ANY OF THESE WARNINGS ARE UNCLEAR, CONTACT Life Fitness Family of Brands CUSTOMER SERVICE IMMEDIATELY AT 1-800-351-3737.

This equipment is categorized as class S per EN ISO 20957-1. As such this equipment is only intended for commercial, institutional and/or studio facilities. It is not intended for home use. Contact Life Fitness Family of Brands with any questions regarding this classification.

It is recommended that all users of Life Fitness Family of Brands exercise equipment be informed of the following information prior to use.

### Operating Warnings



**WARNING:** This product can expose you to chemicals including Methyl Isobutyl Ketone, which is known to the State of California to cause cancer and birth defects or other reproductive harm. For more information go to <http://www.P65Warnings.ca.gov>

- It is the purchaser's sole responsibility to properly instruct its end users and supervising personnel as to the proper operating procedures of all equipment.
- This equipment is not intended for use by children. Keep children under the age of 13 away from the machine.
- Do not allow users to wear loose fitting clothing or jewelry while using equipment. It is also recommended to have users secure long hair back and up to avoid contact with moving parts.
- All bystanders must stay clear of all users, moving parts and attached accessories and components while machine is in operation.

### Access Control

- Life Fitness Family of Brands recommends that all commercial fitness equipment be used in a supervised area. It is recommended that the equipment be located in an access controlled area. Control is the responsibility of the facility owner.

### Installation

- Life Fitness Family of Brands recommends that all equipment be secured to a solid, level surface to stabilize it and eliminate rocking or tipping over. This must be performed by a licensed contractor. See [Bolt to Floor Guide](#) for installation procedure.

### Proper Usage

- Do not use any equipment in any way other than designed or intended by the manufacturer. It is imperative that Life Fitness Family of Brands equipment is used properly to avoid injury.
- Injuries may result if exercising improperly or excessively. It is recommended that all individuals consult a physician prior to commencing an exercise program. If at any time during exercise you feel faint, dizzy or experience pain, STOP EXERCISING and consult your physician.
- Keep body parts (hands, feet, hair, etc.), clothing and jewelry away from moving parts to avoid injury.

### Inspection

- DO NOT attempt to use or repair any accessory approved for use with the equipment which appears to be damaged or worn.
- DO NOT use or permit use of any equipment that is damaged and/or has worn or broken parts. For all Life Fitness Family of Brands equipment use only replacement parts supplied by Life Fitness Family of Brands.
- Maintain labels and name plates - Do not remove labels for any reason. They contain important information. If unreadable or missing, contact Life Fitness Family of Brands customer service for a replacement.
- Equipment Maintenance - Preventative maintenance is the key to smooth operating equipment as well as to keep your liability to a minimum. Equipment needs to be inspected at regular intervals.
- Ensure that any person(s) making adjustments or performing maintenance or repair of any kind is qualified to do so. Life Fitness Family of Brands will provide service and maintenance training at our corporate facility upon request or in the field if proper arrangements are made.
- Before use, examine all accessories approved for use with the Life Fitness Family of Brands equipment for damage or wear.

## **Plate Loaded, Free Weight, and Body Weight Systems**

- If the unit is equipped with weight rods, use only Olympic style weight plates (2.0" bore) for training weight. Do not use dumbbells or any means other than those stated to increase weight resistance - See machine specific section for more information.
- Always utilize weight plate retention devices such as clamps or pins.
- Only add weight plates up to the load limits of the unit. Make sure all weight plates are completely placed on the weight rod.
- Never exceed the load rating for any plate loaded station, body weight station, bench or other free weight device; including specific weight rod and band peg limits. See machine specific section for load limit information.
- Contact a Life Fitness Family of Brands representative with any questions regarding proper weights and loading.

## **Warnings and Cautions**

- Warning labels indicate a potentially hazardous situation that could result in serious injury or death if the precautions are not observed.
- Caution labels indicate a potentially hazardous situation that could result in serious injury or damage to machine if the precautions are not observed.
- Contact [Customer Support Services](#) to replace any worn or damaged labels.

General Warning

**! WARNING**

**SERIOUS INJURY CAN OCCUR ON THIS EQUIPMENT. YOU MUST FOLLOW THESE PRECAUTIONS TO AVOID INJURY!**

1. Before using, read all the warnings and obtain instruction on the use of this machine. Use only for intended exercise. **DO NOT** modify the machine.
2. Obtain a medical exam before beginning any exercise program.
3. Keep body, hair and clothing free of all moving objects.
4. Inspect machine and attachments before use. **DO NOT** use if the machine or attachments appear damaged. **DO NOT** attempt to fix broken or jammed machine or damaged attachments. Notify staff immediately.
5. Be certain that weight pin is completely inserted. Use only the pin provided by the manufacturer. If unsure, seek assistance.
6. Never pin the weights or prop plate into an elevated position. **DO NOT** use the machine if found in this condition. **DO NOT** attempt to fix. Seek assistance.
7. Inspect cables and their connections before using machine. **DO NOT** attempt to fix. Seek assistance.
8. Use only the incremental weights supplied by the manufacturer. **DO NOT** use dumbbells or other means to add resistance to the machine.
9. Children must not be allowed near this machine. Supervise teenagers.
10. Manufacturer recommends that all equipment be secured to the floor to stabilize and eliminate rocking or tipping over. Use a licensed contractor.
11. **DO NOT REMOVE THIS LABEL. REPLACE IF DAMAGED.**

Bar Rack Warning

**! WARNING**

**Bar will fall if hook is not fully engaged into slot.**

**Start Resistance:**  
45 lbs (20 kg)

**Max Load Capacity:**

**Smith Bar:**  
5-45 lbs plates per side  
(4-25 kg plates per side)

**Olympic Bar:**  
8-45 lbs plates per side  
(6-25 kg plates per side)

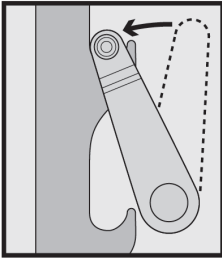

8699701

Bar Stop Warning

**! WARNING**

**Do not use without setting adjustable stop.**

**Proper Adjustments:** Before using machine, adjust stops just below the desired range of motion for the exercise to be performed.

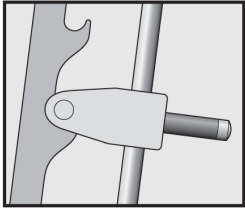

8699601

Serial Number

**SCYBEX**

9525 WEST BRYN MAWR AVE  
ROSEMONT, IL 60018  
USA 1-800-351-3737  
CAGE Code: 0CMY5  
www.cybexintl.com

EN ISO 20957 Class S

Model: **XXX**  
Made in Hungary

Max User Wt: XXXlbs XXXkgs  
Max Training Wt: XXXlbs XXXkgs

SN: XXXXXXXXXXXXX



Pinch Hazard



## Label Locations

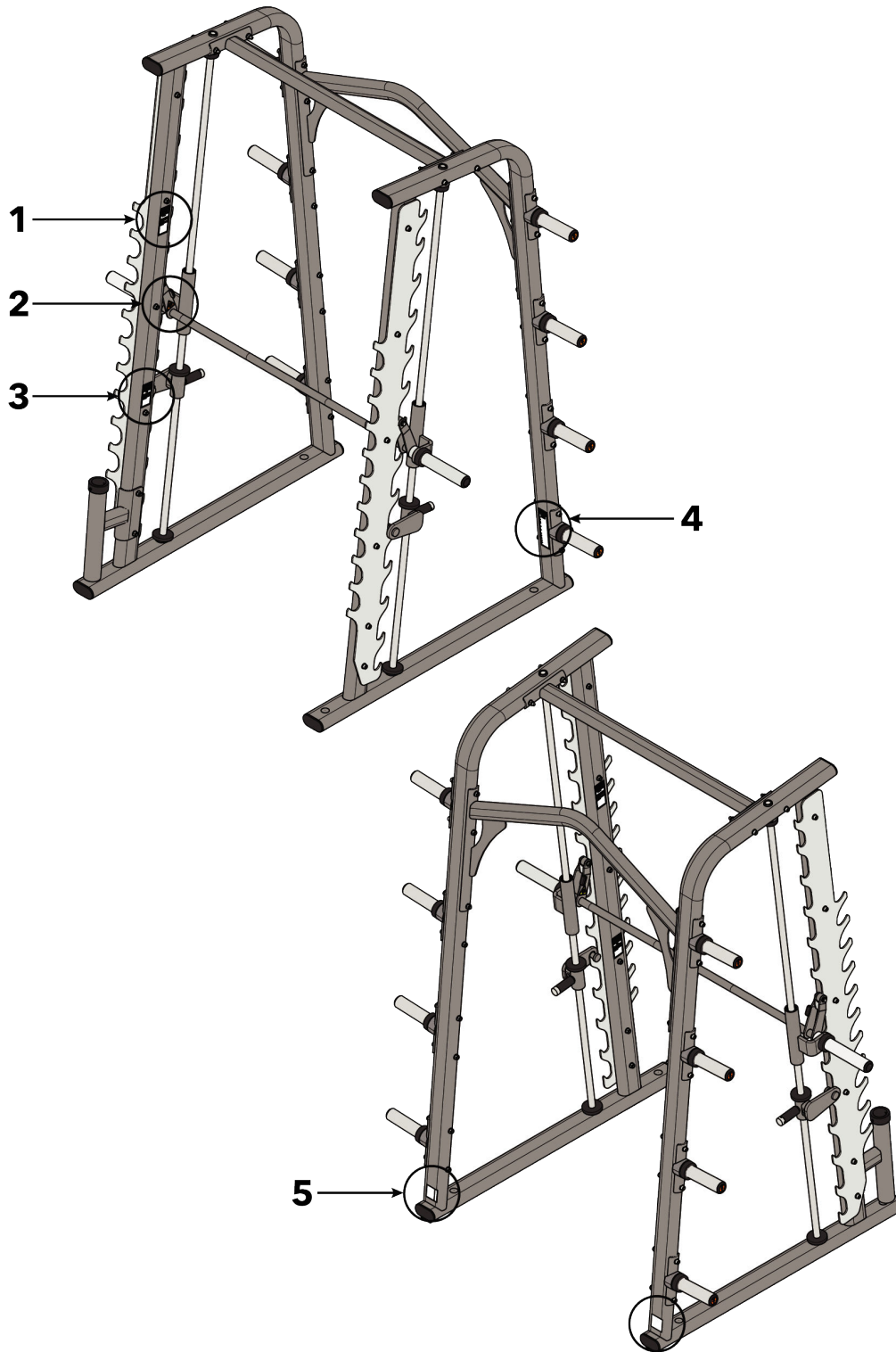

Item	Description	Qty.
1	Bar Rack Warning	2
2	Pinch Hazard	2
3	Bar Stop Warning	2
4	General Warning	1
5	Serial Number	2

# Assembly

## Component and Hardware List

### Components

Item	Description	Qty.
1	Guide Rod	2
2	Top Cross Brace	1
3	Hook Plate	2
4	Right Carriage	1
5	User Bar	1
6	Adjustable Stop	2
7	Left Frame	1
8	Left Carriage	1
9	Right Frame	1
10	Weight Horn Assembly	8
11	Rear Cross Brace	1
12	Weight Horn Label Sheet	1
13	Bar Storage Assembly	1

### Hardware

Item	Description	Qty.
1	Hardware Pack	1
2	3/8" Flat Washer	64
3	M10 Hex Nylock Nut	32
4	M10 x 25mm Bolt	2
5	M10 x 70mm Bolt	10
6	M10 x 80mm Bolt	2
7	M10 x 120mm Bolt	10
8	M10 x 130mm Bolt	10
9	Shaft Collar	2
10	Carriage Bumper	4
11	Shaft Collar Bumper	2
12	Bar End Cap	2
13	Bar End Plate	2
14	Hole Plug	4

## Hardware

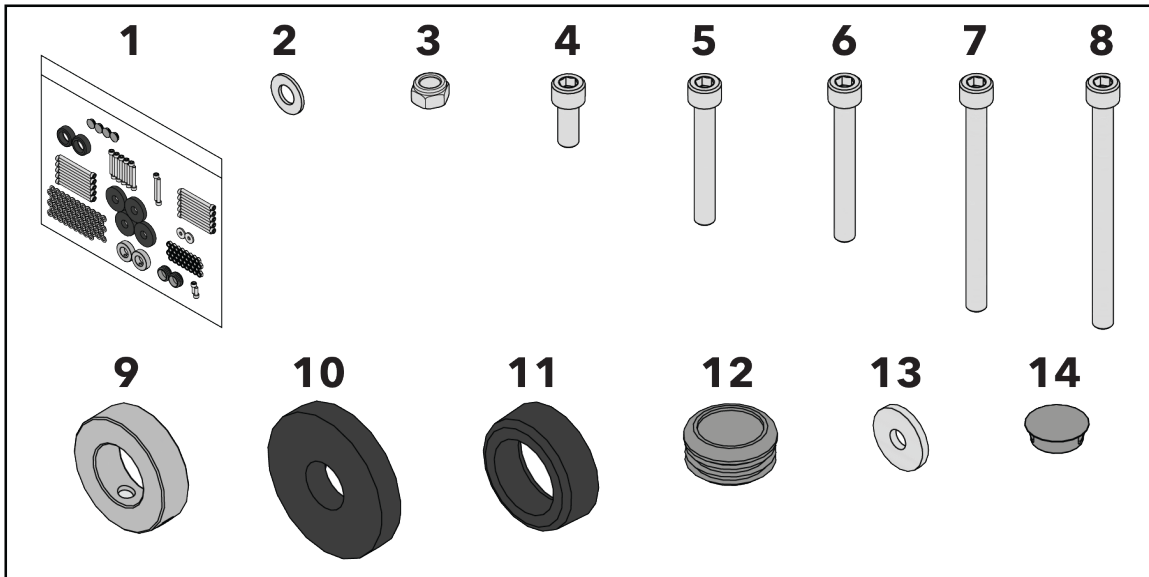

## Tools Required

- 17 mm Socket wrench
- 17 mm Open end wrench
- 5 mm Allen wrench
- 7 mm Allen wrench
- 8 mm Allen wrench
- Torque wrench
- Rubber mallet

## Assembly Procedure

Two people will be required for this procedure.

**TIP:** Read and understand all instructions thoroughly before assembling this unit. Check all items carefully. If there is damage, see the Customer Service section of this manual for proper procedure to return, replace, or reorder parts.

### Install Guide Rods

1. Lay right frame down on the ground.
2. Install guide rod through guide rod hole at the top of the frame.

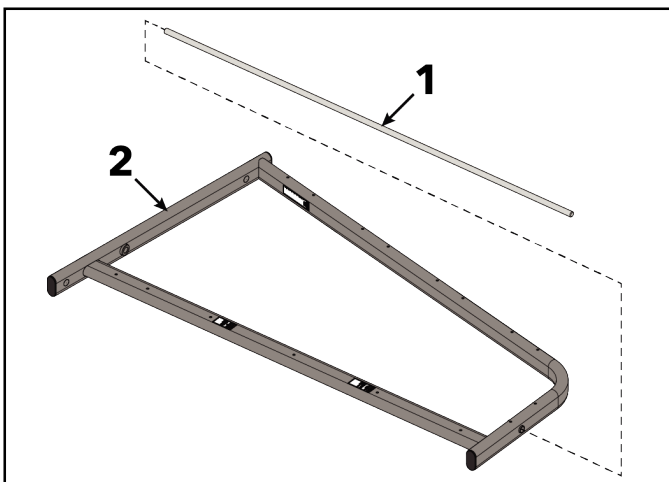

Item	Description	Qty.
1	Guide Rod	1
2	Right Frame	1

3. Repeat steps for left frame and guide rod.

## Assemble Frames

1. Install bolts, washers, and hex nuts securing top cross brace to right frame using an 8mm Allen wrench and 17mm wrench.

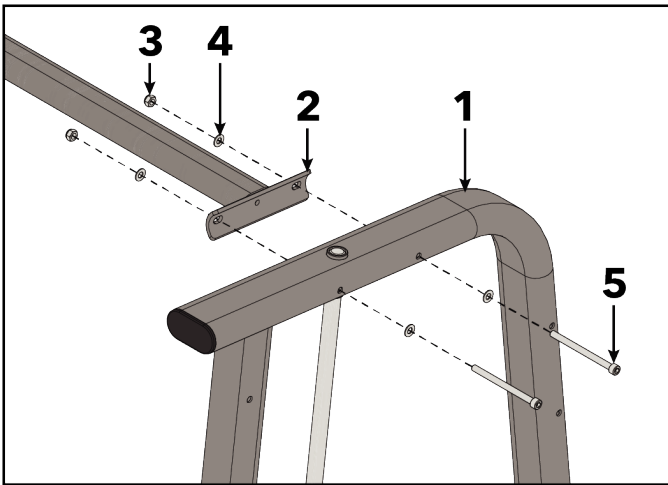

Item	Description	Qty.
1	Right Frame	1
2	Top Cross Brace	1
3	M10 Hex Nylock Nut	2
4	3/8" Flat Washer	4
5	M10 x 130mm Bolt	2



Hand tighten hardware.

**NOTE:** Make sure drain holes in top cross brace are facing the backs of the frames.

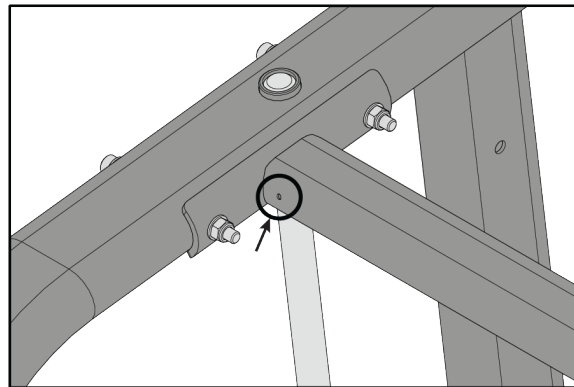

2. Install bolts, washers, and hex nuts securing rear cross brace and two weight horn assemblies to right frame using an 8mm Allen wrench and 17mm wrench.

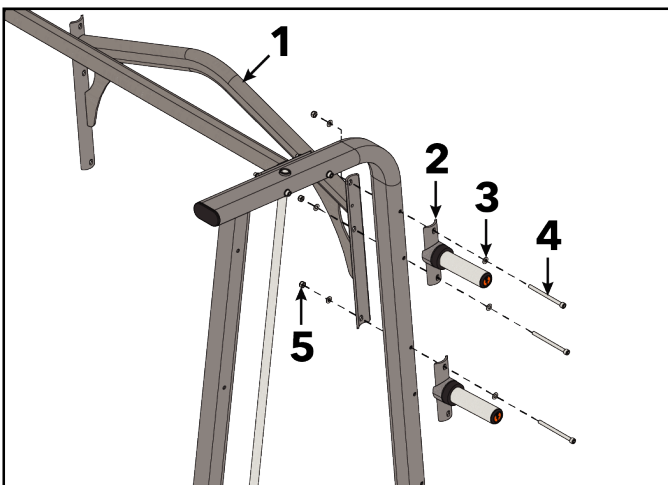

Item	Description	Qty.
1	Rear Cross Brace	1
2	Weight Horn Assembly	2
3	3/8" Flat Washer	6
4	M10 x 130mm Bolt	3
5	M10 Hex Nylock Nut	3



Hand tighten hardware.

3. Repeat steps 1 and 2 to install left frame.

- Install bolts, washers, and hex nuts securing weight horn assemblies to right frame using an 8mm Allen wrench and 17mm wrench.

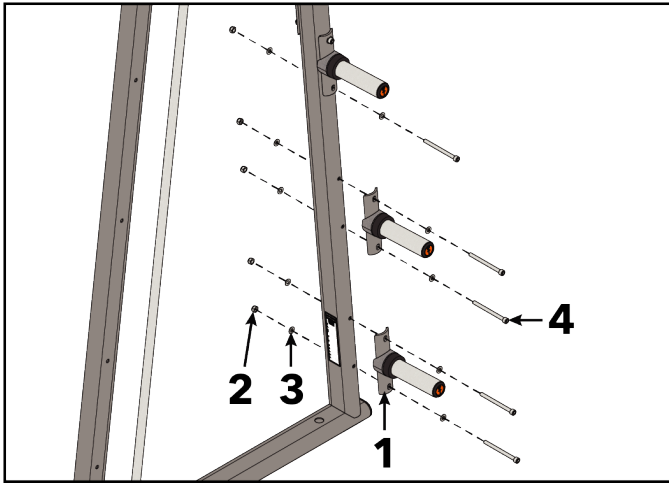

Item	Description	Qty.
1	Weight Horn Assembly	2
2	M10 Hex Nylock Nut	5
3	3/8" Flat Washer	10
4	M10 x 120mm Bolt	5



Hand tighten hardware.

**NOTE:** Make sure arrow sticker on weight horn is pointing UP when installing the weight horns.

- Repeat step 4 for left frame.
- Tighten all bolts to 20-25 ft-lb (27-33 Nm).

## Install Hook Plates

- Install bolts, washers, and hex nuts securing hook plate to right frame using an 8mm Allen wrench and 17mm wrench.

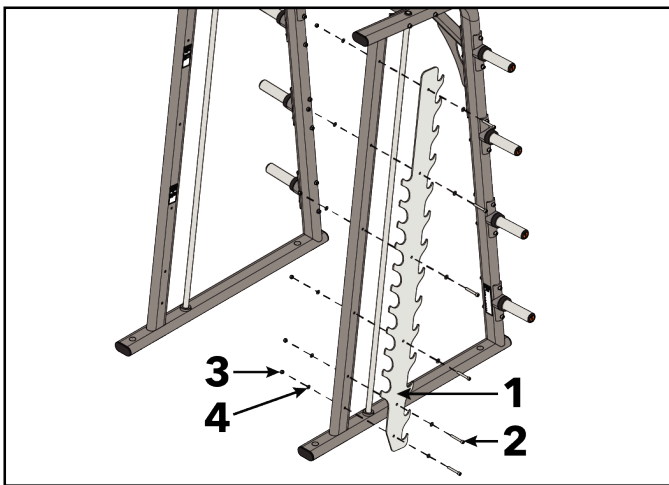

Item	Description	Qty.
1	Hook Plate	1
2	M10 x 70mm Bolt	6
3	M10 Hex Nylock Nut	6
4	3/8" Flat Washer	12



Tighten bolts to 20-25 ft-lb (27-33 Nm).

- Install bolts, washers, and hex nuts securing hook plate to left frame using an 8mm Allen wrench and 17mm wrench.

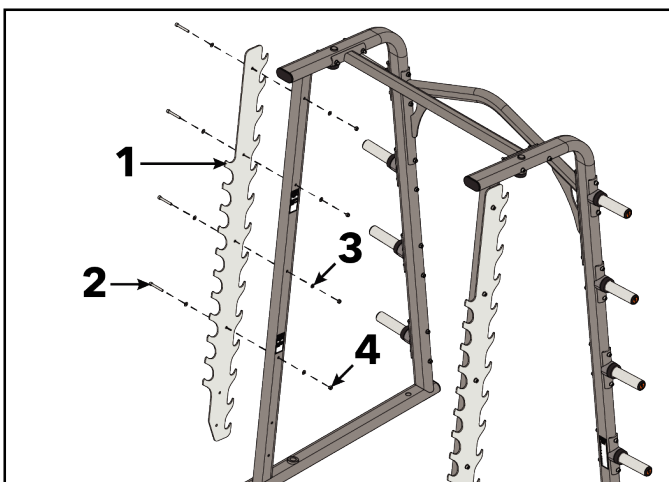

Item	Description	Qty.
1	Hook Plate	1
2	M10 x 70mm Bolt	4
3	3/8" Flat Washer	8
4	M10 Hex Nylock Nut	4



Tighten bolts to 20-25 ft-lb (27-33 Nm).

**NOTE:** Do not install bolts to the bottom two holes of the hook plate on the left side.

## Install User Bar Assembly

1. Make sure rubber bumpers on the user bar are facing up, then slide left and right carriages onto the user bar.

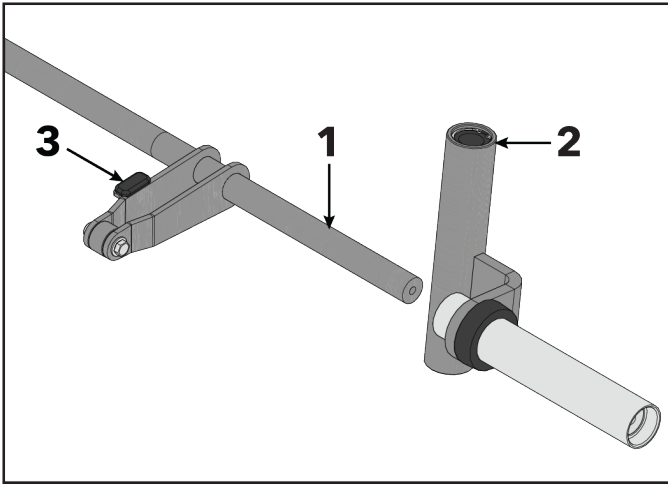

Item	Description	Qty.
1	User Bar	1
2	Left Carriage	1
3	Rubber Bumper	2

2. Install bolts securing bar end plates and carriages to user bar using an 8mm Allen wrench.

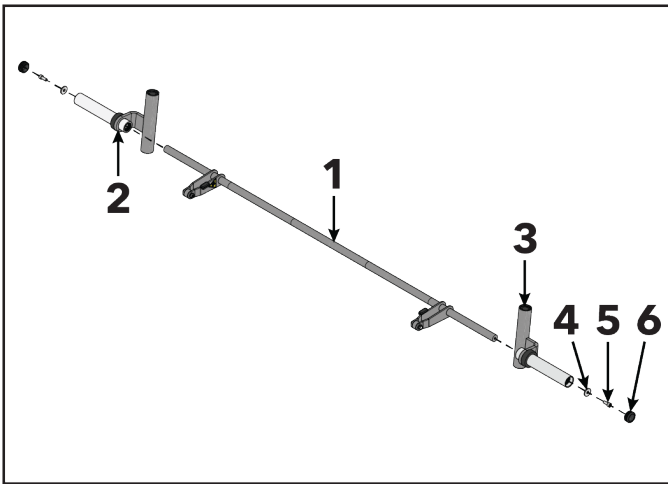

Item	Description	Qty.
1	User Bar	1
2	Right Carriage	1
3	Left Carriage	1
4	Bar End Plate	2
5	M10 x 25mm Bolt	2
6	Bar End Cap	2



Tighten bolts to 20-25 ft-lb (27-33 Nm).

3. Install bar end caps using a rubber mallet.
4. Lift guide rods up and out the tops of the frames.

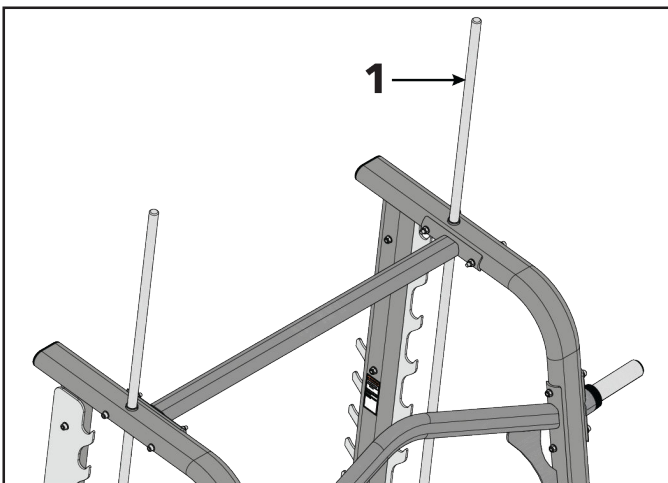

Item	Description	Qty.
1	Guide Rod	2

5. Install shaft collar, shaft collar bumper, user bar assembly, carriage bumpers, and adjustable stop to guide rods. Lower guide rods to the bottom of the frames.

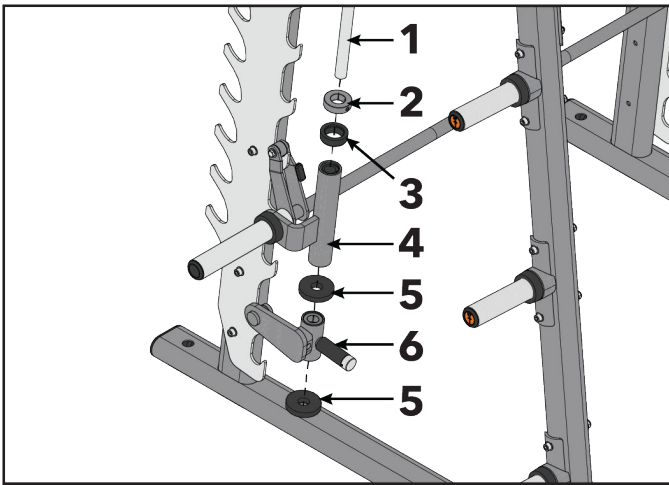

Item	Description	Qty.
1	Guide Rod	2
2	Shaft Collar	2
3	Shaft Collar Bumper	2
4	User Bar Assembly	1
5	Carriage Bumper	4
6	Adjustable Stop	2

6. Install shaft collar and shaft collar bumper to the tops of the left and right frames using a 5mm Allen wrench.

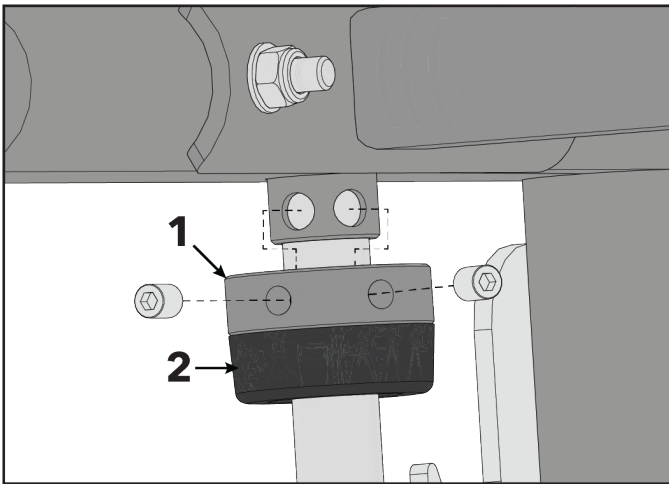

Item	Description	Qty.
1	Shaft Collar	2
2	Shaft Collar Bumper	2



Tighten set screws to 8-10 ft-lbs (11-13.5 Nm).

## Install Hole Plugs

Install hole plugs to frames using a rubber mallet.

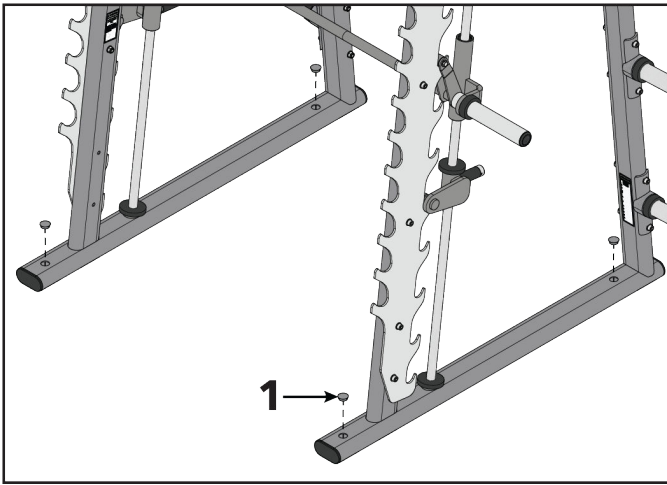

Item	Description	Qty.
1	Hole Plug	4

## Install Bar Storage Assembly

Install bolts, washers, and hex nuts securing bar storage assembly to left frame using an 8mm Allen wrench and 17mm wrench.

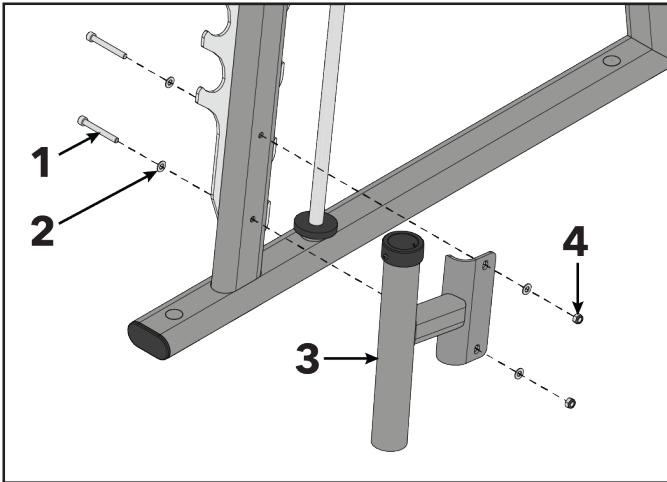

Item	Description	Qty.
1	M10 x 80mm Bolt	2
2	3/8" Flat Washer	4
3	Bar Storage Assembly	1
4	M10 Hex Nylock Nut	2



Tighten bolts to 20-25 ft-lb (27-33 Nm).

## Install Weight Decals

Install weight decals to weight horns.

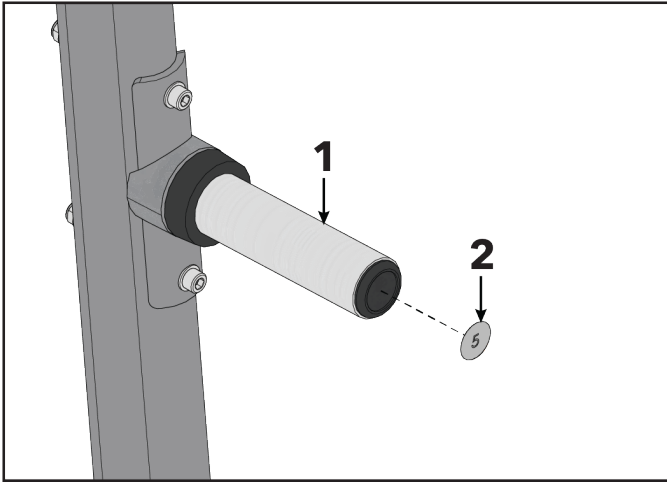

Item	Description	Qty.
1	Weight Horn	8
2	Weight Decal	8

**NOTE:** Weight decal placement.

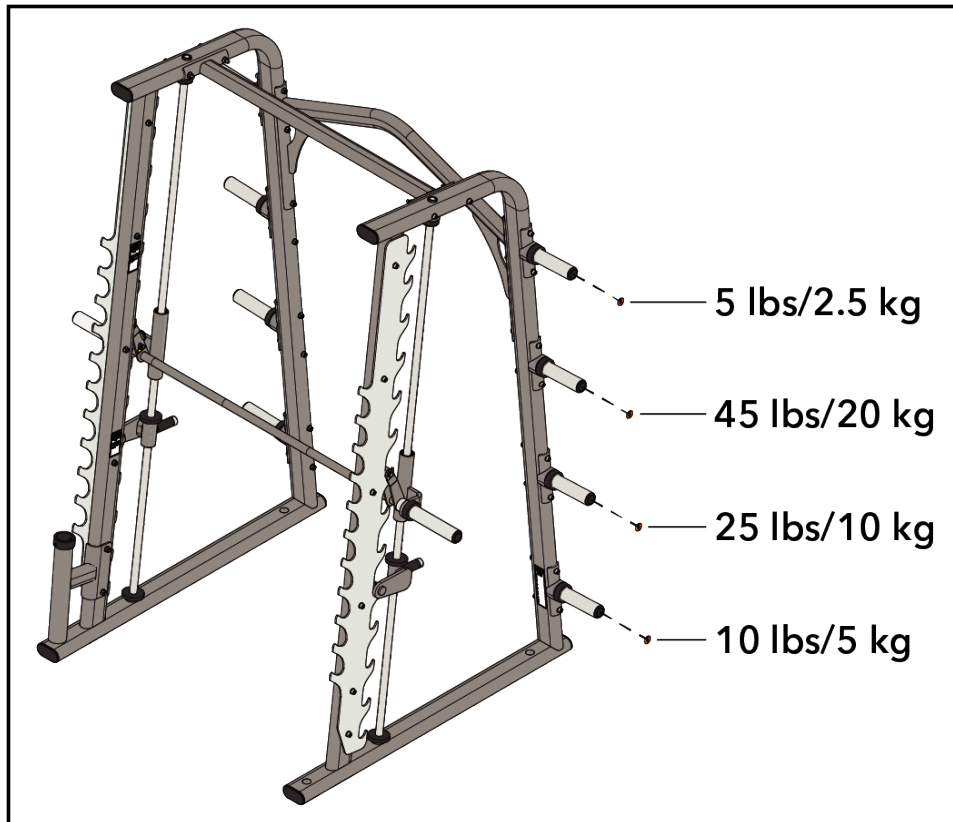

**Test Unit For Proper Operation.**

# Product Information

## Specifications

Machine Weight:	398 lbs.	180 kg.
Size (L x W x H):	in. = 51 x 73 x 88	cm = 130 x 185 x 223
Live Area (L x W):	in. = 120 x 120	cm = 305 x 305
Training Weight:	495 lbs.	220 kg.

### Smith Bar

Plate Capacity:	5-45 lb. plates per weight rod	4-25 kg. plates per weight rod
Start Resistance:	45 lbs.	20 kg.

### Olympic Bar\*

Plate Capacity:	8-45 lb. plates per weight rod	6-25 kg. plates per weight rod
Max Resistance:	765 lbs.	320 kg.

\*Assuming a 45 lb. Olympic-Style Barbell

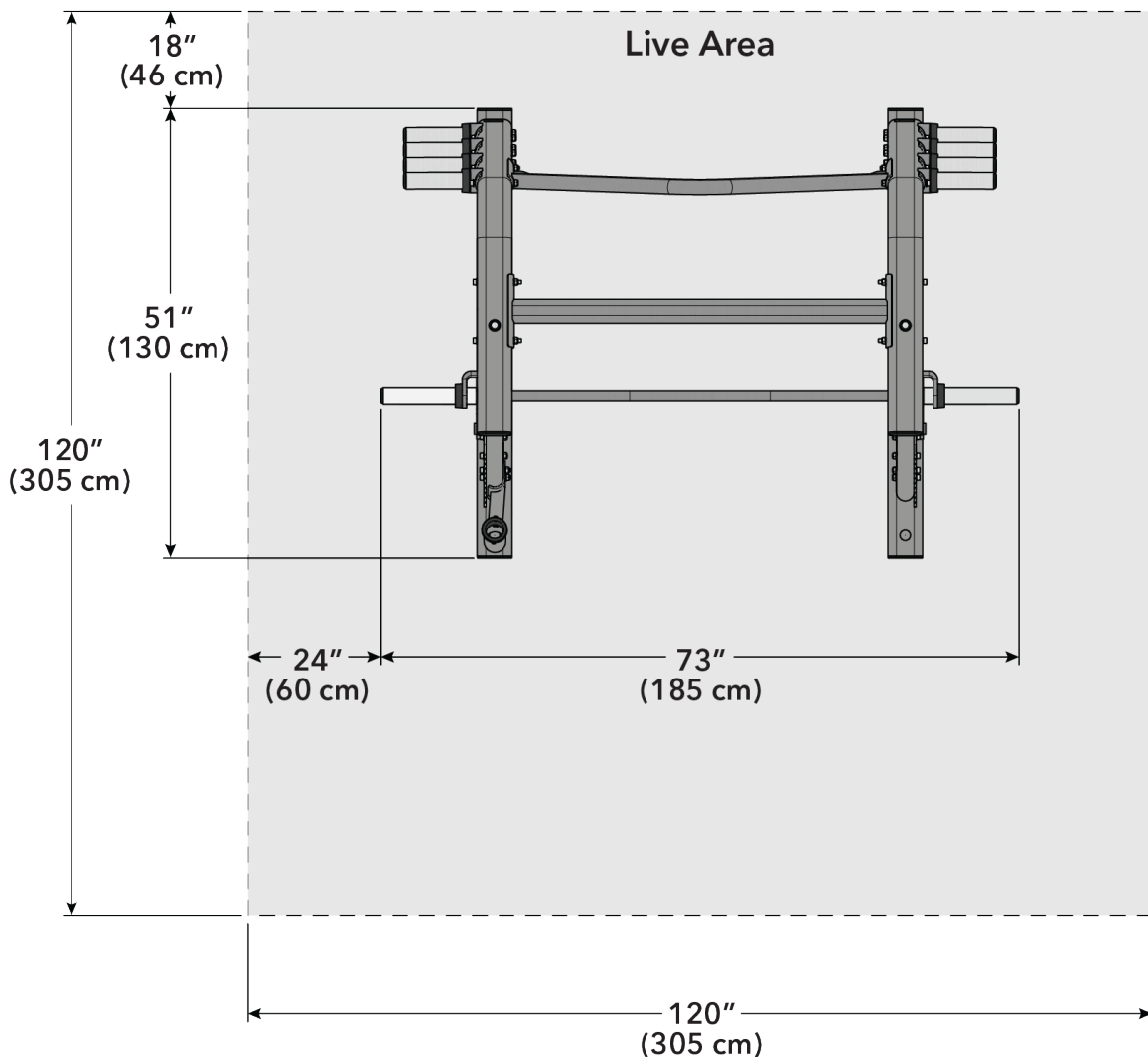

# Exercise

---

## General Exercise Information

---

### Intended Use

The intended commercial use of this machine is to aid exercise and improve general physical fitness. Multiple exercises can be performed using this product. It is the responsibility of the owner to ensure exercisers understand general use and only perform recommended exercises that do not compromise the stability of the product or put the user at risk.

### Prior to Exercise

Prior to starting a training program, get a complete physical exam to make sure your physician agrees that you are ready. Always warm-up your muscles before a workout. A cardio warm-up followed by stretching is typically recommended.

### Start Your Program Conservatively

Choose weights you can easily lift in the first several weeks. Typically, a full range of motion is recommended, but consult a qualified professional if you have questions about whether a full range of motion is appropriate for you due to existing limitations, injury or discomfort. Injuries to health may result from incorrect or excessive training.

A “repetition” (rep) is defined as one complete movement through an exercise, returning to the start position. A “set” is a continuous series of reps, usually between 6-15. During your workout the number of reps you perform in a set depends on your goal. To build muscle and strength, often fewer reps (6 - 8) with heavier weight is recommended in each set. To build endurance, more reps (12-15) with lighter weight is typically recommended.

At the end of your workout, cool down in a similar way to your warm-up.

## Performing the Exercises

---

### General Movements

Adjust the bar to appropriate height for the exercise that will allow the ability to unrack and rack the bar catch. Adjust bar stops to the appropriate height for the exercise. Load bar evenly with appropriate resistance. Unloaded bar = 45lbs (22kg).

Position yourself for the exercise to be performed and grasp the bar. Lift bar and rotate to release the catch. Lift/lower the bar with smooth and controlled movements. Lock bar by rotating until catch is fully engaged. Ensure bar catch is fully engaged over hook before releasing grip on bar.

### Bench Press

**Muscles Used:** Pectoralis and Triceps

**Setup:** The Bench Press exercise is performed with a bench placed under the bar. Sit on the bench facing away from the machine. Lay down in a supine position with the head inside the machine and chest under the bar. Grasp the bar with a shoulder width or wider overhand grip.

**Movement:** Lift bar and rotate to release the catch. Lift/lower the bar with smooth and controlled movements. Lower weight to chest and then press bar back up until arms are extended. Repeat. Lock bar by rotating until catch is fully engaged. Ensure bar catch is fully engaged over hook before releasing grip on bar.

## **Squat Press**

**Muscles Used:** Quadriceps and Gluteus Maximus

**Setup:** Step into the machine and under the bar facing the rear of the machine. Position the bar securely on the back of the shoulders and grasp the bar on both sides with a comfortable width grip.

**Movement:** Lift bar and rotate to release the catch. Lift/lower the bar with smooth and controlled movements. Squat down by bending hips back while allowing the knees to bend forward, keeping back straight. Descend until thighs are near parallel to the floor or as low as your comfortable range of motion allows. Maintaining a straight back, lift the bar by extending at both the knees and hips until legs are straight. Repeat. Lock bar by rotating until catch is fully engaged. Ensure bar catch is fully engaged over hook before releasing grip on bar.

# Maintenance Procedures

## Maintenance Schedule

ACTION	DAILY	WEEKLY	MONTHLY	AS NEEDED
<b>CLEAN</b>				
Guide Rods			X	
Hand Grips				X
<b>WAX</b>				
Frames				X
<b>INSPECT</b>				
Paint			X	
Hardware		X		
Frame		X		
Hand Grips		X		
Drop Stops		X		
<b>LUBRICATE</b>				
Guide Rods				X

### Clean

- Guide rods with a cotton cloth.
- Hand grips with an approved or compatible cleaner.

### Wax

- Frames with a standard, non-abrasive, wax finish.

### Inspect

- Hardware. Check for loosening. Tighten as required.
- Frames. Inspect for wear and damage.
- Handgrips. Check for wear and damage.
- For paint chips. Fill in immediately with manufacturers touch-up paint.
- Drop stops. Check for any signs of cracking or fatigue.

### Lubricate

- Lubricate guide rods with Break-Free® brand lubricant (part number SK50-P0005-0000). Apply the lubricant to a cotton cloth, and then run the cotton cloth up and down the guide rods as needed.

**NOTE:** Only a few drops of lubricant are required for each guide rod.

### Once a Week

- Visually inspect all hardware for loosening, tampering or wear.
- Check condition of hand grips.
- Inspect drop stop for any signs of cracking or fatigue.

### Once a Month

- Clean guide rods with Break-Free® brand lubricant (part number SK50-P0005-0000). Clean tops of bearings at stack and inspect for heavy buildup on rods below the head plate. Lift half of stack and do a visual inspection, then clean as necessary.
- Inspect hardware on all machines and tighten any bolts or nuts that may have loosened over the life of the product.

## Notes

- Use polishing compound (such as car wax) and remove shoe scuffs from powder coated surfaces as necessary.

## Approved and Compatible Cleaners

Two preferred cleaners have been approved by reliability experts: PureGreen 24 and Gym Wipes. Both cleaners will safely and effectively remove dirt, grime and sweat from equipment. PureGreen 24 and the Antibacterial Force formula of Gym Wipes are both disinfectants that are effective against MRSA and H1N1.

PureGreen 24 is available in a spray which is convenient for gym staff to use. Apply the spray to a microfiber cloth and wipe down the equipment. Use PureGreen 24 on the equipment for at least 2 minutes for general disinfection purposes and at least 10 minutes for fungus and viral control.

Gym Wipes are large, durable pre-moistened wipes to use on the equipment before and after workouts. Use Gym Wipes on the equipment for at least 2 minutes for general disinfection purposes.

Contact Customer Support Services to order these cleaners (1-800-351-3737 or email: [customersupport@lifefitness.com](mailto:customersupport@lifefitness.com)).

Mild soap and water or a mild non-abrasive household cleaner can also be used to clean the display and all exterior surfaces. Use a soft microfiber cloth only. Apply the cleaner to the microfiber cloth before cleaning. DO NOT use ammonia or acid based cleaners. DO NOT use abrasive cleaners. DO NOT use paper towels. DO NOT apply cleaners directly to the equipment surfaces.

## Removal of Paint, Marking Pens, or Labels

- Butyl cellosolve works well for removal of paints, marking pen inks, lipstick, etc.
- Labels, stickers, etc. may be removed using kerosene. When the solvent will not penetrate sticker material, apply heat (hair dryer) to soften the adhesive and promote removal. GASOLINE SHOULD NOT BE USED.

# Warranty

---

## **What is Covered**

---

This Life Fitness Family of Brands commercial exercise equipment product is warranted to be free of all defects in material and workmanship.

## **Who is Covered**

---

The original purchaser or any person receiving the product as a gift from the original purchaser.

## **Who Pays Transportation and Insurance For Service**

---

If the Product or any covered part must be returned to a service facility for repairs, We, Life Fitness Family of Brands, will pay all transportation and insurance charges for the first year. You are responsible for transportation and insurance charge after the first year.

## **What We Will Do To Correct Covered Defects**

---

We will ship to you any new or rebuilt replacement part or component, or at our option, replace the Product. Such replacement parts are warranted for the remaining portion of the original warranty period.

## **What is Not Covered**

---

Any failures or damage caused by unauthorized service, misuse, accident, negligence, improper assembly or installation, debris resulting from any construction activities in the Product's environment, rust or corrosion as a result of the Product's location, alterations or modifications without our written authorization, or by failure on your part to use, operate and maintain the Product as set out in your Operation Manual.

*All terms of this warranty are void if this product is moved beyond the continental borders of the United States of America (excluding Alaska, Hawaii and Canada) and are then subject to the terms provided by that country's local authorized Life Fitness Family of Brands representative.*

## **Owner's Manual**

---

It is VERY IMPORTANT THAT YOU READ THIS MANUAL before operating the Product. Remember to perform the periodic maintenance requirements specified in the Manual to assure proper operation and your continued satisfaction.

## **Exclusive Warranty**

---

THIS LIMITED WARRANTY IS IN LIEU OF ALL OTHER WARRANTIES OF ANY KIND EITHER EXPRESSED OR IMPLIED, INCLUDING BUT NOT LIMITED TO THE IMPLIED WARRANTIES OF MERCHANTABILITY AND FITNESS FOR A PARTICULAR PURPOSE, AND ALL OTHER OBLIGATIONS OR LIABILITIES ON OUR PART. We neither assume nor authorize any person to assure for us any other obligation or liability concerning the sale of this Product. Under no circumstances shall we be liable under this warranty, or otherwise, of any damage to any person or property, including any lost profits or lost savings, for any special, indirect, secondary, incidental or consequential damages of any nature arising out of the use of or inability to use this Product. Some states do not allow the exclusion or limitation of implied warranties or of liability for incidental or consequential damages, so the above limitations or exclusions may not apply to you. Warranty coverages and terms may differ outside the United States. Please contact the Life Fitness office servicing your country (contact information found at the front of this manual) or visit the applicable local Life Fitness website to receive the specific warranty information for your country.

## **Changes in Warranty Not Authorized**

---

No one is authorized to change, modify or extend the terms of this limited warranty.

## **Effects of State Laws**

---

This warranty gives you specific legal rights, and you may have other rights which vary from state to state and country by country.

## Warranty Coverage

---

**NOTE:** There is no warranty coverage for labor on Strength Products.

Item	10 Years	5 Years	1 Year	90 Days
Frame	X			
Guide Rods		X		
Grips			X	
Hardware / Mechanical				X
Items Not Specified				X

# Bolt to Floor Guide

---

## Introduction

---

Cybox designs its products to be stable when used as designed. Because strength training is dynamic, we cannot predict how users will ultimately use the products in all circumstances. Therefore, Cybox recommends that strength training equipment be secured to a solid, level surface to stabilize and eliminate rocking or tipping over.

Each new unit shipped comes with a multi-language hangtag stating the importance of bolting the unit down as a safety precaution.

It is the facility's responsibility to adhere to local and regional building codes.

## Delivery and Installation Tips

---

### All Anchors

- Fasteners must have minimum embedment in concrete floor, not including screed, regardless of wood/tile/rubber over sub-floor. (See *Anchor Types* for maximum sub-floor thickness between unit and concrete to equipment foot must be made of flooring or other material (i.e. no air gaps)).
- DO NOT reuse fasteners. Static and Dynamic anchors are designed for one-time use only.
- Factor in equipment's feet height when selecting fastener length.
- Factor in flooring thickness when selecting fastener length.
- It is also recommended to drill an additional 1/2" (12.7 mm) of depth beyond the length of the fastener being used to ensure that debris does not block the entry of the anchor.
- Minimum concrete compressive strength: 3000 psi (20 N/mm<sup>2</sup>).

### Anchoring

- All anchors must have a minimum embedment into concrete, regardless of wood/tile/rubber/screed over sub-floor.
- Dynamic anchors must have a minimum embedment depth in concrete to ensure maximum security and pull out force. See *Anchor Types* for embedment depth minimums.

### Building Codes

It is the facility's responsibility to adhere to local and regional building codes. Please verify with the customer to ensure that they are aware of this.

### Carpeting

If bolted down to carpet flooring, be sure to use a box cutter knife to cut the carpet threads around each foot. This will help avoid the carpet threads from being wrapped around and pulled by the drill bit.

### Competitor Product

The bolt down guidelines and procedures for Cybox products were determined by the company's Engineering and Installation Development groups. These guidelines include which anchors to use and positioning of the anchors are required for Cybox product.

- Cybox does not have that level of specification or engineering input for competitive product.
- Cybox installation teams are not permitted to anchor competitor equipment.

### Drilling

It is also recommended to drill an additional 1/2" (12.7 mm) of depth beyond the length of the fastener being used to ensure that debris does not block the entry of the anchor.

- This can be done by marking your drill bit with a piece of tape.
- While it is recommended that a vacuum be used to clean up debris, this will not account for all the debris that will settle at the bottom of the drilled hole.

## Anchor Types

Anchor		Subfloor between unit and concrete 0" to 1/2" (12.7mm) thick	Subfloor between unit and concrete over 1/2" (12.7mm) thick
Static	Imperial	KH-EZ 1/4" x 4"	KH-EZ 1/4" x 5"
	Metric	HUS-H 6mm x 120mm	HUS-H 6mm x 150mm

## Anchor Specifications

Static Anchor	Minimum Concrete Thickness	Minimum Drill Depth in Concrete	Minimum Concrete Embedment	Minimum concrete compressive strength
KH-EZ 1/4"	4-1/8" (105mm)	1/2" (12.7mm) beyond anchor length	2-1/2" (63.5mm)	3000psi (20 N/mm <sup>2</sup> )
HUS-H 6mm	3-3/32" (100mm)	25/64" (10mm) beyond anchor length	2-1/64" (55mm)	3000psi (20 N/mm <sup>2</sup> )

## Pullout Force

Cybex specifies Hilti™ static and dynamic anchors. According to the anchor manufacturer, the recommended design pullout force (in tension) for the specified anchors, when properly installed in cracked concrete, is provided in the side table. This table should be used for reference only; for additional and up-to-date information on the anchor capabilities or the design pullout force in other substrates, please consult Hilti directly at <https://www.us.hilti.com>.

Selected Anchor	Design Resistance in Tension *
KH-EZ 1/4" x 4"	830 lb
HUS-H 6MM x 120MM	3.3 kN
KH-EZ 3/8" x 4"	1535 lb
KH-EZ 3/8" x 5"	1535 lb
HUS-H 8MM x 120MM	3.3 kN
HUS-H 8MM x 150MM	3.3 kN
HSL-3 M 8/40	2000 lb
HST M12 x 115/20	8 kN
HST M12 x 195/200	8 kN
KB-TZ 3/8" x 3-3/4"	1615 lb

\* Design strength extracted from the Hilti Anchor Fastening Technology Manual issued September 2014.

## Tools Required

 **WARNING:** Adhere to manufacturer's equipment warnings and guidelines. Follow manufacturer's instructions for proper usage.

### Static Anchor

- Floor scanner / rebar detector (optional)
- 1" L-shape SDS rotary hammer
- 1/4" x 12" (6mm x 305mm) carbide drill bit (for 1/4" (6mm) anchors)
- 3/8" x 12" (8mm x 305mm) carbide drill bit (for 3/8" (8mm) anchors)
- Safety glasses
- Extension cord
- Impact wrench
- Vacuum (for debris)

## Static Anchor Procedure



**CAUTION:** If it is possible that the length of your bolt will not provide the minimum requirement of 2.5" (63.5mm) of engagement, a longer anchor should be used.

1. Place unit into position to be mounted and cycle unit to set stance.
2. Each foot **must** get at least one static fastener.
3. Wearing protective glasses, drill down into the flooring to the required depth as perpendicular as possible, ensuring that the foot thickness is being accounted for; refer to *Anchor Selection* and *Foot Dimensions*.

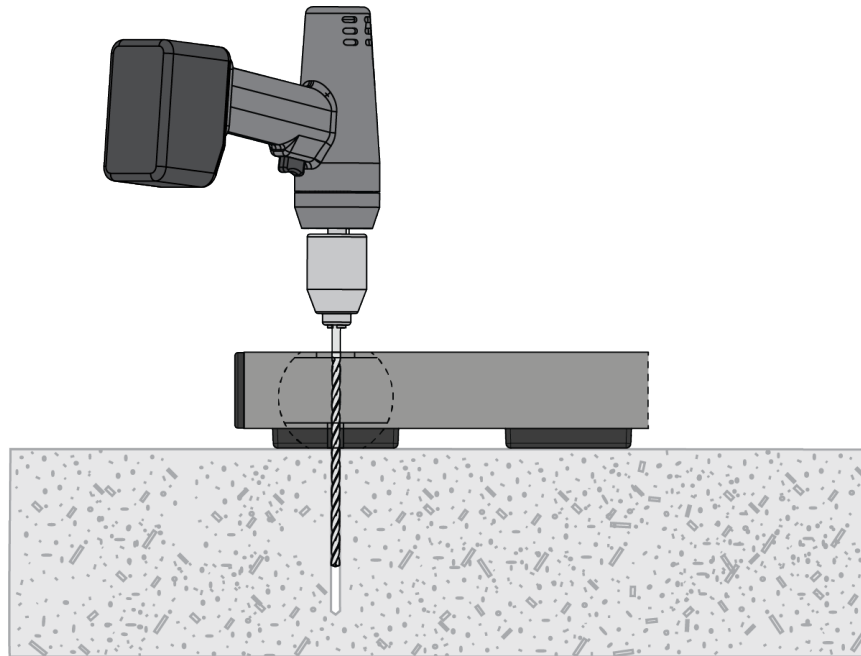

4. Insert fastener and tighten to 18 Foot-Pounds (24Nm) for 1/4" (6mm) anchor or 40 Foot-Pounds (54Nm) for 3/8" (8mm) anchor.

**NOTE:** If the legs/frame do not contact the mounting surface **DO NOT** pull down with the fastener or anchor. Loosen frame hardware and re-tighten to allow machine to align.

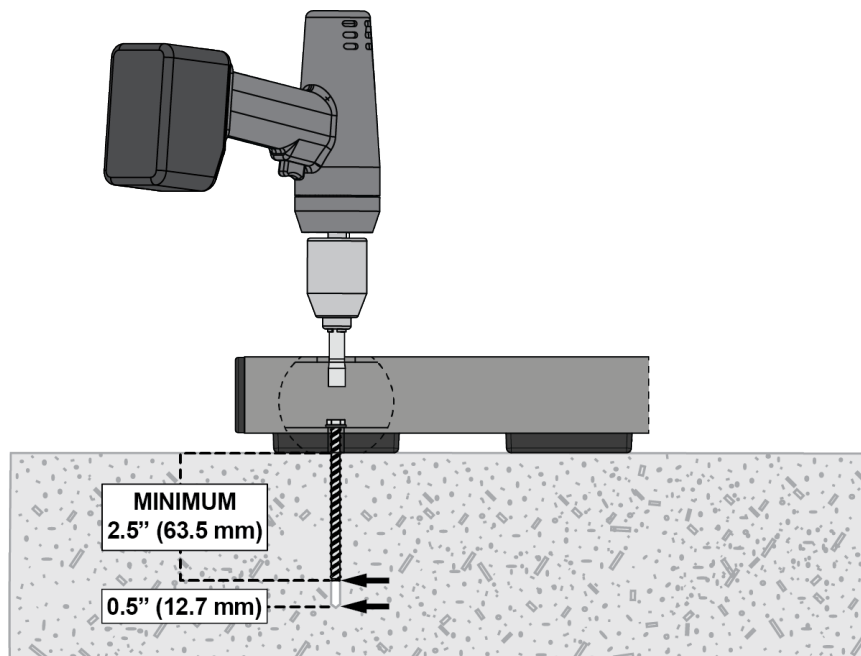

## Foot Dimensions

---

Use below image to determine foot specifications.

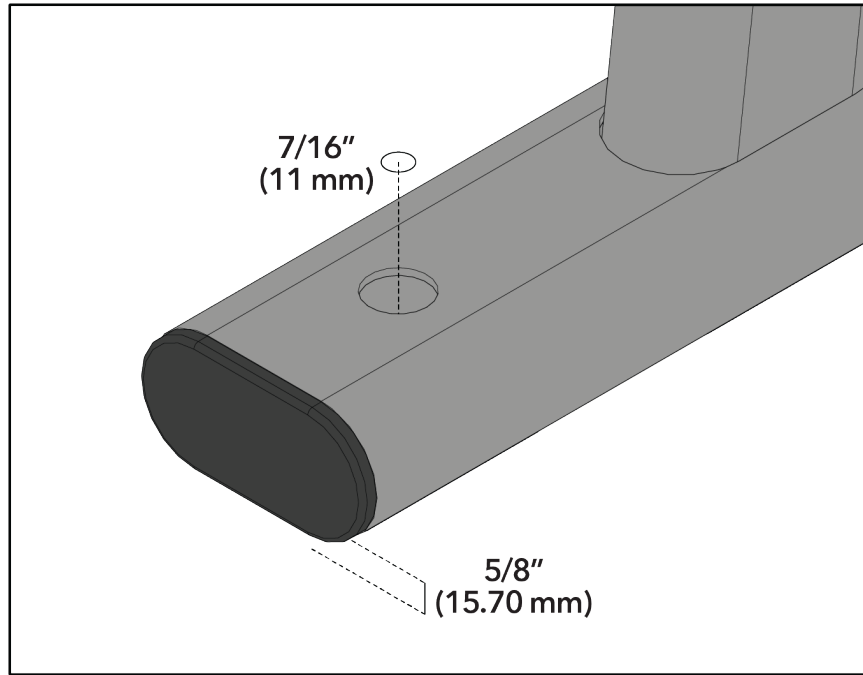





Columbia Center III - 9525 West Bryn Mawr Ave, Rosemont, IL 60018 • 800-351-3737 • 847-288-3700 • FAX 800-216-8893

[www.cybexintl.com](http://www.cybexintl.com)