

INTEGRITY CROSS-TRAINER

INXSC, INXSX, INXDX, INXSSE, INXST, INXDSE, INXDST, CLUB SERIES +,
PF-INT-XT

Assembly Instructions



Corporate Headquarters

10601 W Belmont Ave, Franklin Park, IL 60131 • U.S.A.
847.288.3300 • FAX: 847.288.3703
Service phone number: 800.351.3737 (toll-free within U.S.A., Canada)
Global Website: www.lifefitness.com

International Offices

AMERICAS

North America

Life Fitness, LLC

10601 W Belmont Ave
Franklin Park, IL 60131 U.S.A.
Telephone: (847) 288 3300
Service Email:
customersupport@lifefitness.com
Sales/Marketing Email:
commercialsales@lifefitness.com

Brazil

Life Fitness Brasil

Av. Rebouças, 2315
Pinheiros
São Paulo, SP 05401-300
BRAZIL
SAC: 0800 773 8282 option 2
Telephone: +55 (11) 3095 5200 option 2
Service Email: suportebr@lifefitness.com
Sales/Marketing Email:
vendasbr@lifefitness.com

Latin America and Caribbean*

Life Fitness, LLC

10601 W Belmont Ave
Franklin Park, IL 60131 U.S.A.
Telephone: (847) 288 3300
Service Email:
customersupport@lifefitness.com
Sales/Marketing Email:
commercialsales@lifefitness.com

EUROPE, MIDDLE EAST, and AFRICA (EMEA)

Netherlands and Luxemburg

Life Fitness Atlantic BV

Bijdorplein 25-31
2992 LB Barendrecht
THE NETHERLANDS
Telephone: (+31) 180 646 666
Service Email:
service.benelux@lifefitness.com
Sales/Marketing Email:
marketing.benelux@lifefitness.com

United Kingdom

Life Fitness UK LTD

Queen Adelaide
Ely, Cambs, CB7 4UB
Telephone: General Office (+44)
1353.666017
Customer Support (+44) 1353.665507
Service Email: uk.support@lifefitness.com
Sales/Marketing Email: life@lifefitness.com

Germany, Austria, and Switzerland

Life Fitness Europe GMBH

Neuhofweg 9
85716 Unterschleißheim
GERMANY
Telephone:
+49 (0) 89 / 31775166 Germany
+43 (0) 1 / 6157198 Austria
+41 (0) 848 / 000901 Switzerland
Service Email:
kundendienst@lifefitness.com
Sales/Marketing Email:
vertrieb@lifefitness.com

Spain

Life Fitness IBERIA

C/Frederic Mompou 5,1ª^a
08960 Sant Just Desvern Barcelona
SPAIN
Telephone: (+34) 93.672.4660
Service Email:
servicio.tecnico@lifefitness.com
Sales/Marketing Email:
info.iberia@lifefitness.com

Belgium

Life Fitness Benelux NV

Parc Industriel de Petit-Rechain
4800 Verviers
BELGIUM
Telephone: (+32) 87 300 942
Service Email:
service.benelux@lifefitness.com
Sales/Marketing Email:
marketing.benelux@lifefitness.com

All Other EMEA Countries and Distributor Business EMEA*

Life Fitness Atlantic BV

Bijdorplein 25-31
2992 LB Barendrecht
THE NETHERLANDS
Telephone: (+31) 180 646 644
Service Email:
EMEAServiceSupport@lifefitness.com

ASIA PACIFIC (AP)

Japan

Life Fitness Japan, Ltd

4-17-33 Minami Aoyama 1F/B1F
Minato-ku - Tokyo 107-0062
Japan
Telephone: (+81) 0120.114.482
Fax: (+81) 03-5770-5059
Service Email: service.lfj@lifefitness.com
Sales/Marketing Email:
sales@lifefitnessjapan.com

Hong Kong

Life Fitness Asia Pacific LTD

32/F, Global Trade Square
21 Wong Chuk Hang Road
Hong Kong
Telephone: (+852) 2575.6262
Service Email: Service.HK@lifefitness.com
Sales/Marketing Email:
hongkong.sales@lifefitness.com

All Other Asia Pacific countries and distributor business Asia Pacific*

Life Fitness Asia Pacific LTD

32/F, Global Trade Square
21 Wong Chuk Hang Road
Hong Kong
Telephone: (+852) 2575.6262
Fax: (+852) 2575.6894
Service Email: Service.AP@lifefitness.com
Sales/Marketing Email:
Marketing.HK.Asia@lifefitness.com

*Also check www.lifefitness.com for local representation or distributor/dealer

User and Service Documents Link

<https://lifefitness9512.zendesk.com/hc/en-us>

<https://www.lftechsupport.com/web/document-library/documents>

Additional information is available online using the links above.

تتوفر معلومات إضافية على الإنترنت باستخدام الرابط أعلاه.

点击上面的链接可在线获取更多信息。

Flere oplysninger er tilgængelige online gennem linket ovenfor.

Bijkomende informatie is online beschikbaar via bovenstaande link.

Vous trouverez plus d'informations en ligne à l'aide du lien ci-dessus.

Zusätzliche Informationen finden Sie online über den oben angegebenen Link.

Ulteriori informazioni sono disponibili online utilizzando il link sopra riportato.

追加情報は上記リンクを使用してオンラインで利用可能です。

상기 링크를 통해 온라인에서 추가 정보를 볼 수 있습니다.

Informações adicionais estão disponíveis on-line, através do link acima.

Дополнительная информация доступна в интернете по ссылке, указанной выше.

Mediante el enlace anterior podrá acceder a información adicional en línea.

Ytterligare information finns online genom att använda länken ovan.

İnternet üzerinden daha fazla bilgi edinmek için yukarıdaki bağlantıyı kullanabilirsiniz.

هناك معلومات إضافية متاحة على الإنترنت باستخدام الرابط أعلاه.

Informazio osagarria eskuragarri dago goiko estekaren bidez.

Допълнителна информация можете да намерите онлайн, като използвате връзката по-горе.

Mitjançant l'enllaç anterior podreu accedir a informació addicional en línia.

使用上面的連結線上提供額外資訊。

Dodatne informacije možete pronaći na internetu sljedeći vezu iznad.

ከላይ የተመጠውን አገናኝ(ሊንክ) በመጠቀም መረጃዎች አንላይን ያገኛሉ።

Lisätietoja on saatavissa verkosta käyttämällä yllä olevaa linkkiä.

Wubetumi anya nsem afoforo aka ho wa websait so denam asem a ewa atifi ho a wubemia so so.

Πρόσθετες πληροφορίες είναι διαθέσιμες online χρησιμοποιώντας το σύνδεσμο παραπάνω.

מידע נוסף אפשר לקבל באינטרנט באמצעות הקישור לעיל.

További információ elérhető online, a fenti hivatkozás segítségével.

Viðbótarupplýsingar eru fáanlegar á netinu með því að smella á tengilinn hér fyrir ofan.

Plus indicium per superum situm potes invenire.

മുകളിലുള്ള ലിങ്ക് ഉപയോഗിച്ച് ഓൺലൈനിൽ കൂടുതൽ വിവരങ്ങൾ ലഭ്യമാണ്.

Ytterligere informasjon er tilgjengelig på nettet via linken ovenfor.

Dodatkowe informacje są dostępne online pod powyższym odnośnikiem.

Informações adicionais estão disponíveis online a usar o link acima.

Informații suplimentare sunt disponibile online, utilizând link-ul de mai sus.

Dodatne informacije dostupne su na mreži putem gornjeg linka.

Ďalšie informácie sú dostupné online na vyššie uvedenom odkaze.

Table of Contents

Getting Started

Safety Instructions.....	4
Consignes de Sécurité.....	6
Where to Place and How to Stabilize the Cross-Trainer.....	8
Electrical Power Requirements (Applicable for Units Using External Power Supply).....	9
Check for Console Power.....	9
Power Assist Option / External Power Supply.....	9

Attach Moving Handles.....	24
Attach Upper Right and Left Shrouds.....	24
Attach Middle Shroud.....	25
Insert Cup Holder.....	25
Attach Deadshaft Covers.....	26

Specifications

Specifications.....	27
---------------------	----

Product Overview

INXDX, Club Series +.....	10
INXSX, INXSC, PF-INT-XT.....	10
INXSSE, INXST.....	10
INXDSE, INXDST, Club Series +.....	11
Connections.....	11
How to Use the Cross-Trainer.....	11
Mounting and Dismounting the Cross-Trainer.....	11

Service and Technical Data

Preventive Maintenance Tips.....	12
Approved and Compatible Cleaners.....	12
Preventive Maintenance Schedule.....	13
Troubleshooting the Polar® Heart Rate Chest Strap.....	13
Troubleshoot the Lifepulse™ Sensors.....	14
Recycle the Battery.....	14
How to Obtain Product Service.....	14

Assembly: INXSC, INXSX, INXDX, INXSSE, INXST, INXDSE, INXDST, CLUB SERIES +

Hardware and Required Tools.....	15
Before You Begin.....	16
Attach Bullhorn.....	17
Attach Moving Handles.....	17
Attach Upper Right and Left Shrouds.....	18
Attach Middle Shroud.....	18
Insert Cup Holder.....	18
Attach Deadshaft Covers.....	19
Base to Console Cable Connections - Integrity X or Integrity C.....	20
Base to Console Cable Connections - Discover SE3 / SE3 HD / ST.....	20
Attach Console.....	20
Attach Rear Console Shroud Assembly.....	21

Assembly: PF-INT-XT

Hardware and Required Tools.....	22
Before You Begin.....	23
Attach Bullhorn.....	24

Life Fitness® is a registered trademark.

Gym Wipes® is a registered trademark of the 2XL Corporation. PureGreen 24 is a trademark of Pure Green. Polar® is a registered trademark of Polar Electro Inc.

© Copyright 2021, Life Fitness, LLC. All Rights Reserved. Life Fitness, Hammer Strength, Cybex, ICG and SCIFIT are registered trademarks of Life Fitness, LLC and its affiliated companies and subsidiaries. Brunswick and related trademarks used under license from Brunswick Corporation. Disclaimer: Images and specifications are current as of the date of publication and are subject to change.

10601 W Belmont Ave, Franklin Park, IL 60131 • 847-288-3300

www.lifefitness.com • 1006908-0001 AF • 2021

1. Getting Started

Safety Instructions

 Read all instructions before use.

 **CAUTION:** Any changes or modifications to this equipment could void the product warranty.

 **WARNING:** Health-related injuries may result from incorrect or excessive use of exercise equipment. Life Fitness Family of Brands STRONGLY recommends seeing a physician for a complete medical exam before undertaking an exercise program, particularly if the user has a family history of high blood pressure or heart disease, is over the age of 45, smokes, has high cholesterol, is obese, or has not exercised regularly in the past year. If, at any time while exercising, the user experiences faintness, dizziness, pain, or shortness of breath, he or she must stop immediately.

 **WARNING:** To reduce the risk of burns, fire, electric shock, or injury, it is imperative to connect each product to a properly grounded electrical outlet.

 **WARNING:** Heart rate monitoring systems may be inaccurate. Over exercising may result in serious injury or death. If you feel faint, stop exercising immediately.

 **WARNING:** Do not use for stretching and do not attach straps or other devices.

 **WARNING:** Keep batteries out of reach of children.

Some chest straps may contain a removable battery.

- Swallowing may lead to serious injury in as little as 2 hours or death, due to chemical burns and potential perforation of the esophagus.
- If you suspect your child has swallowed a battery, immediately call your local poison control for fast, expert advice.
- Examine devices and make sure the battery compartment is correctly secured, e.g. that the screw or other mechanical fastener is tightened. Do not use if compartment is not secure.
- Dispose of used button batteries immediately and safely. Flat batteries can still be dangerous.
- Tell others about the risk associated with button batteries and how to keep their children safe.

 **WARNING:** Ensure that there is at least 1 ft. (0.3 m) of clearance in front of the Cross-Trainer and at least 2 ft. (0.6m) on the side.

 **WARNING:** The Cross-Trainer is not equipped with a free-wheeling feature. Therefore, the product cannot be stopped immediately.

 **WARNING:** This product can expose you to chemicals including Acrylonitrile, which is known to the State of California to cause cancer and birth defects or other reproductive harm. For more information go to <http://www.P65Warnings.ca.gov>

 **DANGER:** To reduce the risk of electrical shock or injury from moving parts, always unplug product before cleaning or attempting any maintenance activity.

- Never operate the product if it has a damaged power cord or electrical plug, or if it has been dropped, damaged, or even partially immersed in water. Contact Customer Support Services.
- Position the product so that the power cord plug to the wall is accessible to the user. Make sure that the power cord is not knotted or twisted and that it is not trapped under any equipment or other objects.
- If the electrical supply cord is damaged, it must be replaced by the manufacturer, an authorized service agent, or a similarly qualified person to avoid a hazard.
- Always follow the console instructions for proper operation.
- This appliance is not intended for use by persons (including children) with reduced physical, sensory, or mental capabilities, or lack of experience or knowledge unless they have supervision or been given instruction concerning the use of the appliance by a person responsible for their safety.
- Do not use this product outdoors, near swimming pools or in areas of high humidity.
- Never operate the product with the air openings blocked. Keep air openings free of lint, hair, or any other obstructing material.
- Never insert objects into any opening in these products. If an object should drop inside, turn off the power, unplug the power cord from the outlet, and carefully retrieve it. If the item cannot be reached, contact Customer Support Services.
- Never place liquids of any type directly on the unit, except in an accessory tray or holder. Containers with lids are recommended.

- Do not use these products in bare feet. Always wear shoes. Wear shoes with rubber or high-traction soles. Do not use shoes with heels, leather soles, cleats or spikes. Make sure no stones are embedded in the soles.
- Keep all loose clothing, shoelaces, and towels away from moving parts.
- Do not reach into, or underneath, the unit or tip it on its side during operation.
- This equipment is not intended for use by children. Keep children under the age of 14 away from the machine.
- Do not allow other people to interfere in any way with the user or equipment during a workout.
- Allow LCD consoles to “normalize” with respect to temperature for one hour before plugging the unit in and using.
- The product should never be left unattended when plugged in. Disconnect from the electrical outlet when not in use, and before putting on or taking off parts.
- Use these products for their intended use as described in this manual. Do not use attachments that have not been recommended by the manufacturer.
- Free standing equipment shall be installed on a stable and leveled surface.
- Do not stand or sit on the rear plastic covers of the Cross-Trainer.
- Do not stand on center tube of the Cross-Trainer.
- The individual human power required to perform an exercise may be different than the mechanical power displayed on the Cross-Trainer.
- Never face backward while using the Cross-Trainer.
- Use caution when mounting or dismounting the Cross-Trainer. Before mounting, use the moving arms to bring the pedal nearest to you to the lowest position. Use the stationary handlebars whenever additional stability is required. While exercising, hold onto the moving arms.
- Read all warnings on each product prior to starting a workout.
- If warnings are missing or damaged, please contact Customer Support Services immediately for replacement warning labels. Warning labels are shipped with every product and should be installed before product is used. Life Fitness Family of Brands is not responsible for missing or damaged warning labels.

Consignes de Sécurité

 Veuillez lire toutes les instructions avant usage.



ATTENTION : Toute modification apportée à cet équipement pourrait en annuler la garantie.



AVERTISSEMENT : Une utilisation incorrecte ou excessive de l'appareil peut entraîner des blessures. Life Fitness Family of Brands Recommande VIVEMENT aux utilisateurs de passer un examen médical complet avant d'entamer un programme d'entraînement, et tout particulièrement dans les cas suivants : antécédents familiaux d'hypertension (pression sanguine trop élevée) ou de pathologies cardiaques, utilisateurs de 45 ans ou plus, tabagisme, hypercholestérolémie (taux de cholestérol sanguin trop élevé), obésité, absence d'exercice physique depuis un an ou plus. Si, pendant l'usage de l'appareil, l'utilisateur éprouve un malaise, des vertiges, des douleurs ou des difficultés à respirer, il doit s'arrêter immédiatement.



AVERTISSEMENT : Pour réduire les risques de brûlures, d'incendies, de décharges électriques ou de blessures, il est essentiel de brancher chaque appareil sur une prise électrique correctement mise à la terre.



AVERTISSEMENT : Les systèmes de surveillance de la fréquence cardiaque peuvent être inexacts. Un exercice trop intensif peut entraîner des blessures graves, voire mortelles. En cas de malaise, interrompez immédiatement l'exercice.



AVERTISSEMENT : Ne pas utiliser pour des étirements et ne pas y attacher des sangles ou autres dispositifs.



AVERTISSEMENT : Tenir les piles hors de portée des enfants.

Certaines sangles de poitrine peuvent contenir une pile jetable.

- L'ingestion de la pile peut provoquer des blessures graves voire la mort en moins de 2 heures en raison du risque de brûlures chimiques et de perforation de l'œsophage.
- Si vous pensez que votre enfant a avalé une pile, contactez immédiatement le centre anti-poison local pour obtenir des conseils spécifiques.
- Contrôlez l'appareil et assurez-vous que le compartiment pour pile est bien fermé, par exemple que la vis ou toute autre fixation mécanique est bien serrée. Ne pas utiliser le produit si le compartiment n'est pas bien fermé.
- Éliminer les piles bouton immédiatement et de manière sûre. Les piles bouton sont une source de danger.
- Informez les tiers des risques associés aux piles bouton et de la manière dont ils doivent agir pour protéger leurs enfants.



AVERTISSEMENT : Veillez à laisser un dégagement d'au moins 30 cm devant le Cross-Trainer et d'au moins 60 cm sur les côtés.



AVERTISSEMENT : Le Cross-Trainer n'est pas équipé d'une option roue libre. Par conséquent, il ne peut être arrêté instantanément.



AVERTISSEMENT : This product can expose you to chemicals including Acrylonitrile, which is known to the State of California to cause cancer and birth defects or other reproductive harm. For more information go to <http://www.P65Warnings.ca.gov>



DANGER : Pour réduire les risques de chocs électriques ou de blessures en raison des pièces mobiles, débranchez toujours les produits avant de les nettoyer ou de procéder aux tâches d'entretien.

- Ne faites jamais fonctionner le produit dont la fiche ou le cordon d'alimentation sont altérés ni aucun appareil qui serait tombé, aurait été endommagé ou même partiellement plongé dans l'eau. Contactez le service à la clientèle.
- Placez l'appareil de façon à ce que l'utilisateur ait accès à la fiche du cordon d'alimentation. Assurez-vous que le cordon d'alimentation n'est pas noué ou tordu et qu'il n'est pas coincé sous un autre appareil ou sous tout autre objet.
- Si le cordon d'alimentation électrique est endommagé, il doit être remplacé par le fabricant, par un réparateur agréé ou par une personne qualifiée afin d'éviter tout danger.
- Pour un fonctionnement correct, suivez toujours les instructions de la console.
- Cet appareil n'est pas destiné à être utilisé par des personnes ou des enfants présentant des capacités physiques, sensorielles ou mentales réduites, ou un manque d'expérience et de connaissances, sauf en cas de supervision ou d'instructions relatives à son utilisation par une personne responsable de leur sécurité.
- N'utilisez pas ce produit à l'extérieur, près d'une piscine ou dans des endroits très humides.
- N'utilisez jamais le produit avec les ouvertures d'air bloquées. Maintenez les bouches d'aération exemptes de peluches, de cheveux ou de toute autre obstruction.
- N'insérez jamais d'objet dans les ouvertures de cet appareil. Si un objet tombe dans l'appareil, mettez ce dernier hors tension, débranchez le cordon d'alimentation et récupérez l'objet avec précaution. Si vous ne pouvez pas l'atteindre, contactez le service d'assistance à la clientèle.

- Ne placez jamais de liquides d'aucune sorte directement sur l'appareil, sauf si vous disposez d'un support ou d'un plateau pour accessoires. Nous vous recommandons de n'utiliser que des récipients pourvus d'un bouchon.
- N'utilisez pas ces produits avec les pieds nus. Portez toujours des chaussures. Portez des chaussures à semelles en caoutchouc ou antidérapantes. N'utilisez pas de chaussures à talon, à semelle en cuir, à crampons ou à pointes. Assurez-vous qu'aucun caillou ne s'est incrusté dans les semelles.
- Éloignez les vêtements amples, les lacets de chaussure et les serviettes des parties mobiles de l'appareil.
- Ne placez pas les mains à l'intérieur ou sous l'appareil. Ne le faites pas basculer sur le côté durant son fonctionnement.
- Cet équipement n'est pas destiné à être utilisé par les enfants. Tenez les enfants âgés de moins de 14 ans à l'écart de la machine.
- Ne laissez aucune personne gêner l'utilisateur ou le fonctionnement de l'appareil pendant l'exercice.
- Laissez les consoles LCD s'adapter à la température ambiante pendant une heure avant de brancher l'appareil et de l'utiliser.
- Ne laissez jamais l'appareil sans surveillance lorsqu'il est branché. Débranchez-le systématiquement après son utilisation, et avant l'ajout et le retrait de pièces.
- Utilisez cet équipement uniquement aux fins auxquelles il est destiné et de la manière décrite dans le présent manuel. N'utilisez pas d'accessoires non recommandés par le fabricant.
- L'appareil utilisé de manière autonome doit être installé sur une surface stable et plane.
- Ne vous mettez pas debout ni assis sur les caches en plastique situés à l'arrière du Cross-Trainer.
- Ne vous mettez pas debout sur le tube central du Cross-Trainer.
- La puissance nécessaire à chaque utilisateur pour effectuer un exercice peut différer de la puissance mécanique affichée sur le Cross-Trainer.
- Ne montez jamais à l'envers sur le Cross-Trainer.
- Montez et descendez du Cross-Trainer avec la plus grande précaution. Avant de monter, placez la pédale située de votre côté en position basse, en vous aidant des bras mobiles. Utilisez les poignées fixes lorsque vous avez besoin de renforcer votre équilibre. Pendant les exercices, tenez les bras mobiles.
- Lisez les avertissements sur chaque produit avant de commencer à vous entraîner.
- Si certaines étiquettes d'avertissement sont manquantes ou endommagées, contactez immédiatement le service d'assistance à la clientèle. Nous vous en fournirons de nouvelles. Les étiquettes d'avertissement sont expédiées avec les appareils et doivent être installées avant utilisation de ces derniers. Life Fitness Family of Brands n'est pas responsable des étiquettes manquantes ou endommagées.

Where to Place and How to Stabilize the Cross-Trainer

Read the entire manual before setting up the cross-trainer. After following all Safety Instructions, move the unit to the location where it will be used. Allow 1 ft. (0.3 m) of clearance in front of the cross-trainer and at least 2 ft. (0.6 m) on the side. It should be easy to mount the cross-trainer from the side.

Free area

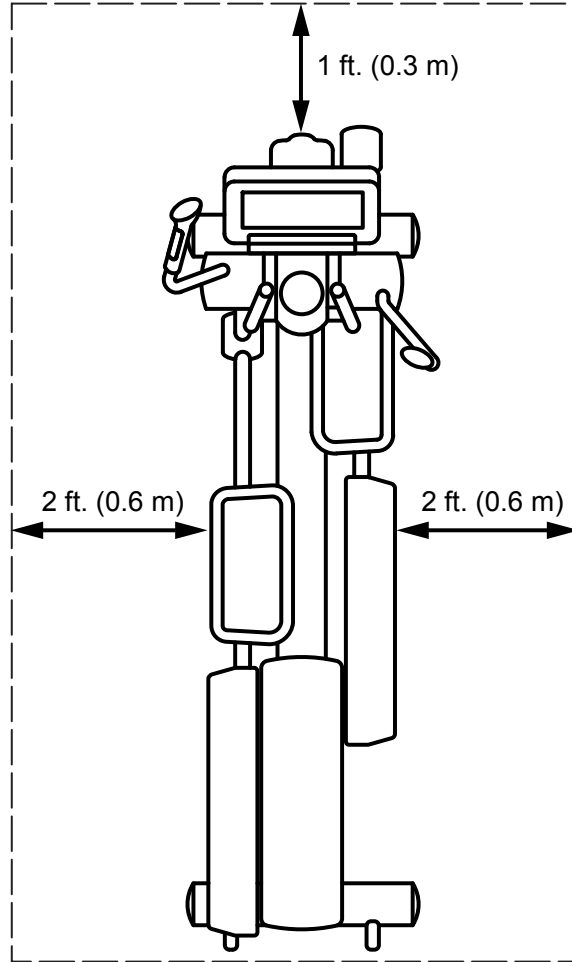

After placing the unit in position, check the unit's stability by attempting to rock it from side to side. Any slight rocking indicates that the unit must be leveled. Determine which foot is not resting completely on the floor. Loosen the jam nut with an open-end M17 wrench and rotate the stabilizing foot to lower it. Verify that the unit is stable. Repeat the adjustment as necessary until the unit no longer rocks. Lock the adjustment by tightening the jam nut against the stabilizing bar.

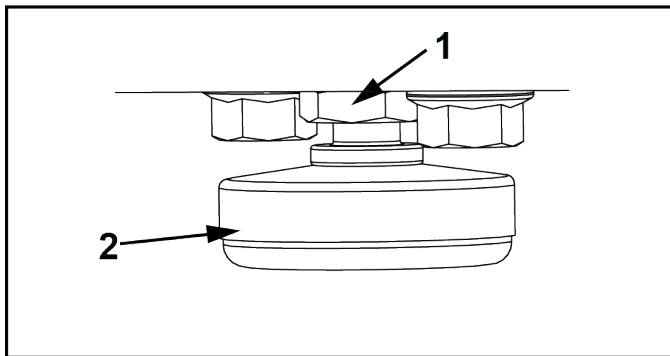

	Description
1	Jam Nut
2	Stabilizing Leg

Electrical Power Requirements (Applicable for Units Using External Power Supply)

This unit is self powered or can be used with an optional external power supply. Use of an attachable TV requires an external 12V power supply. Use of a Discover Console requires a 24V power supply.

 **WARNING:** Use only the supplied power brick and line cord. Do not use any modification to connect to a 2-prong outlet. Product must be connected to a properly rated 3-prong outlet.

Console	Supply Voltage	Frequency	Output Voltage	Output Current
Integrity X / Integrity C	95 - 264 VAC	47 - 63 Hz	12 VDC	5 A
Discover SE3 / SE3 HD / ST	95 - 264 VAC	47 - 63 Hz	24 VDC	2.5 A

 **WARNING:** DO NOT USE A 24VDC POWER SUPPLY WITH INTEGRITY CONSOLES!

Outlet Voltage	Commercial Units Outlet & Breaker (Amps)	Consumer / Home Units Outlet & Breaker (Amps)
120 VAC	20 (no more than 10 cross-trainers per breaker for Integrity; 5 cross-trainers per breaker for Discover)	15 (no more than 8 cross-trainers per breaker for Integrity; 4 cross-trainers per breaker for Discover)
230 VAC	12 (no more than 10 cross-trainers per breaker for Integrity; 5 cross-trainers per breaker for Discover)	12 (no more than 8 cross-trainers per breaker for Integrity; 4 cross-trainers per breaker for Discover)

NOTE: Do not modify the plug provided with this product. If the plug does not fit into an available electrical outlet, have a proper outlet installed by a qualified electrician.

NOTE: Make sure the power brick cord is securely connected to the base unit. A loose connection may result in the unit not receiving external power.

Check for Console Power

The Integrity X and Integrity C consoles are powered by a rechargeable 6-volt battery. Check the battery by pressing the GO button. The console should beep and light up. The console will display the Life Fitness logo. If a prompt doesn't appear, mount the unit and begin pedaling. The console should light up and programming a workout should be possible. Pedal for 10 - 20 minutes at 50 rpm or faster during a workout for optimum battery charging. The pedal action during workouts keeps the battery charged. Optional external power supply can be used. If the unit is externally powered, battery maintenance is automatic and pedaling is not required. Use only the power supply provided by *Life Fitness* to insure against unsafe operation.

Power Assist Option / External Power Supply

The cross-trainer's optional Power Assist feature makes it possible for the console to be powered by an external electrical source. This eliminates the need to pedal at a minimum speed to supply constant power to the console. With this option, users who use the cross-trainer for rehabilitative exercise may pedal at a rate below the minimum without losing console power.

Plug the power to the external power connector on the front end of the cross-trainer. Plug the cord into an AC outlet. Use only the external power supply provided by *Life Fitness* in order to insure against unsafe operation.

 **CAUTION:** Connectors should easily fit into the receptacles. Forcing a connection may lead to damage to the barrel connector and/or receptacle and may void product warranty. If the power supply barrel doesn't fit easily into the receptacle then the wrong power supply is being used.

The Power Assist feature option requires an optional kit. Contact Life Fitness Customer Support Services to order the kit.

2. Product Overview

INXDX, Club Series +

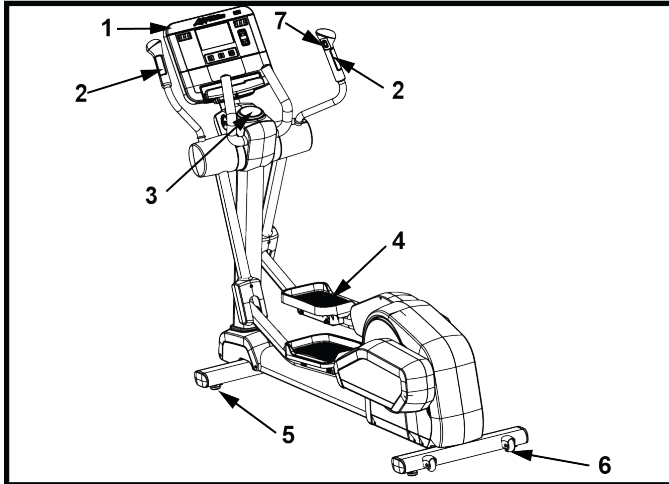

Item	Description
1	Console
2	Contact Heart Rate Sensors
3	Cup Holder
4	Pedal
5	Leg Leveler
6	Transport Wheels
7	Resistance Level Up / Down Controls

INXSX, INXSC, PF-INT-XT

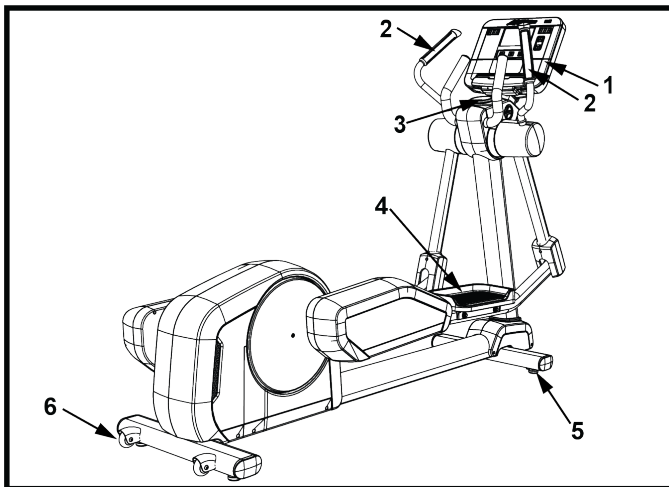

Item	Description
1	Console
2	Contact Heart Rate Sensors
3	Cup Holder
4	Pedal
5	Leg Leveler
6	Transport Wheels

INXSSE, INXST

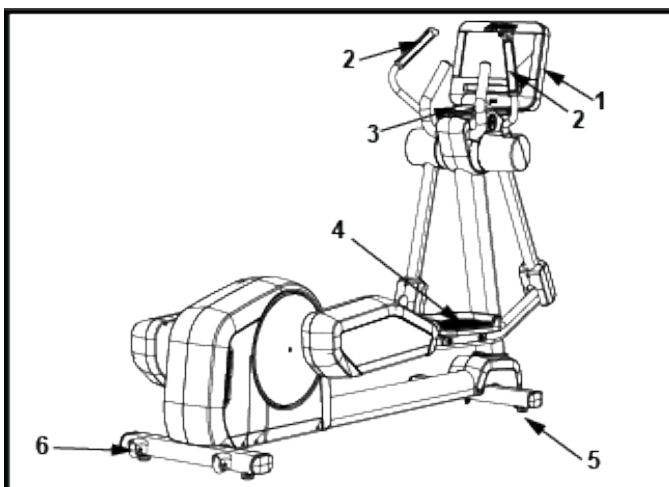

Item	Description
1	Console
2	Contact Heart Rate Sensors
3	Cup Holder
4	Pedal
5	Leg Leveler
6	Transport Wheels

INXDSE, INXDST, Club Series +

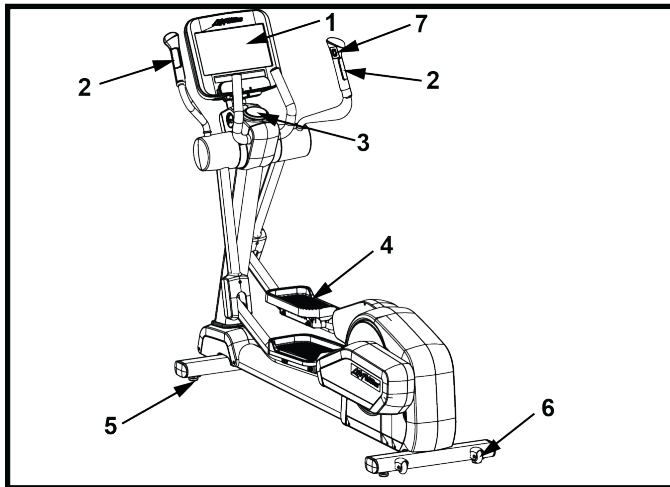

Item	Description
1	Console
2	Contact Heart Rate Sensors
3	Cup Holder
4	Pedal
5	Leg Leveler
6	Transport Wheels
7	Resistance Level Up / Down Controls

Connections

The following connection receptacle is located at the front of the cross-trainer.

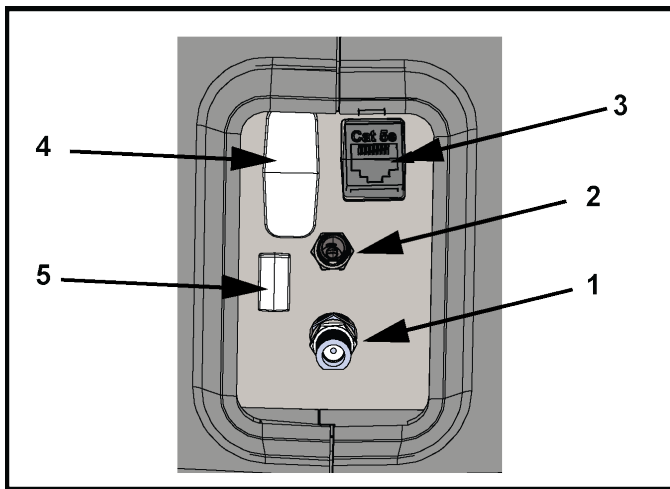

Item	Description
1	Coaxial Connection
2	Power Input
3	CAT5e Network / Ethernet
4	HDMI Connection
5	IR Connection

How to Use the Cross-Trainer

Place feet anywhere on the pedals that feel comfortable. Many users put their toes 1-2" from the front edge of the pedals and 0.5-1" from the inside edge of the pedals. However, the pedals are large enough to allow a range of foot positions depending on preference. Using a combination of upper body strength with the moving handles and lower body strength at the feet, begin to rotate the pedals in a forward motion like walking. The cross-trainer can be used in a slow motion like walking or a faster motion like jogging and running. A typical usage speed is 50 - 60 revolutions of the pedals per minute. The user can concentrate more or less force on the moving handles to vary the degree of upper and lower body recruitment. The stationary bullhorn handles can also be used instead of the moving handles, to focus the effort on the lower body only. For added variation, the cross-trainer can be used in a backwards motion.

Mounting and Dismounting the Cross-Trainer

Before mounting, use the moving arms to bring the pedal nearest you to its lowest position. Grasp the stationary handles and carefully step on the pedals. To dismount, rotate the pedals so the pedal you are stepping off is in the lowest position. Step off the pedals while still holding the stationary handles. Then let go of the handles.

3. Service and Technical Data

Preventive Maintenance Tips

NOTE: Safety of the equipment can be maintained only if the equipment is examined regularly for damage or wear. Keep the equipment out of use until defective parts are repaired or replaced. Pay special attention to parts that are subject to wear, as outlined below.

REMARQUE : Pour assurer la sécurité du matériel, il convient de l'inspecter régulièrement afin de déceler tout signe d'usure ou d'endommagement. N'utilisez pas l'appareil avant d'avoir réparé ou remplacé les pièces défectueuses. Portez une attention toute particulière aux pièces qui s'usent, comme indiqué ci-dessous.

The following preventive maintenance tips will keep the product operating at peak performance:

- Locate the product in a cool, dry place.
- Clean the display console and all exterior surfaces with an approved or compatible cleaner (see Approved and Compatible Cleaners) and a microfiber cloth.
- Long fingernails may damage or scratch the surface of the console; use the pad of the finger to press the selection buttons on the console.
- Clean the top surface of the pedals regularly.
- Clean the housing and moving arms thoroughly on a regular basis.

NOTE: When cleaning the exterior of the unit, a non-abrasive cleaner and soft cotton cloth are strongly recommended. At no time should cleaner be applied directly to any part of the equipment.

Approved and Compatible Cleaners

Two preferred cleaners have been approved by reliability experts: PureGreen 24 and Gym Wipes. Both cleaners will safely and effectively remove dirt, grime and sweat from equipment. PureGreen 24 and the Antibacterial Force formula of Gym Wipes are both disinfectants that are effective against MRSA and H1N1.

PureGreen 24 is available in a spray which is convenient for gym staff to use. Apply the spray to a microfiber cloth and wipe down the equipment. Use PureGreen 24 on the equipment for at least 2 minutes for general disinfection purposes and at least 10 minutes for fungus and viral control.

Gym Wipes are large, durable pre-moistened wipes to use on the equipment before and after workouts. Use Gym Wipes on the equipment for at least 2 minutes for general disinfection purposes.

Contact Customer Support Services to order these cleaners (1-800-351-3737 or email: customersupport@lifelife.com).

Mild soap and water or a mild non-abrasive household cleaner can also be used to clean the display and all exterior surfaces. Use a soft microfiber cloth only. Apply the cleaner to the microfiber cloth before cleaning. DO NOT use ammonia or acid based cleaners. DO NOT use abrasive cleaners. DO NOT use paper towels. DO NOT apply cleaners directly to the equipment surfaces.

Preventive Maintenance Schedule

Item	Weekly	Monthly	Biannually
Console Overlays	Clean		Inspect
Bottle Holders / Accessory Trays	Clean	Inspect	
Console Mounting Bolts			Inspect
Hardware			Inspect
Frame	Clean		Inspect
Plastic Covers	Clean	Inspect	
Lifepulse Sensors	Clean / Inspect		
Leg Levelers		Inspect / Adjust	
Pedals	Clean	Inspect	

Troubleshooting the Polar® Heart Rate Chest Strap

Heart rate reading is erratic or absent entirely

Probable Cause	Corrective Action
Belt transmitter electrodes are not wet enough to pick up accurate heart rate readings.	Wet the belt transmitter electrodes.
Belt transmitter electrodes are not laying flat against the skin.	Ensure the belt transmitter electrodes are laying flat against the skin.
Belt transmitter needs cleaning.	Wash the belt transmitter with mild soap and water.
Belt transmitter not properly set up.	Setup of the belt transmitter is accomplished by initially bringing it with in 1 foot of the receiver. The receiver is in the console. After the heart rate is displayed on the console the range is extended to 3 feet.
Chest strap battery is depleted.	Contact Customer Support Services for instructions on how to have the chest strap replaced.

Abnormally elevated heart rate readings

Probable Cause	Corrective Action
Electromagnetic interference from television sets and/or antennas.	Move the exercise equipment a few inches away from the probable cause, or move the probable cause a few inches away from the exercise equipment, until the heart rate readings are accurate.
Electromagnetic interference from cell phones.	
Electromagnetic interference from computers.	
Electromagnetic interference from cars.	
Electromagnetic interference from high voltage power lines.	
Electromagnetic interference from motor driven exercise equipment.	

Troubleshoot the Lifepulse™ Sensors

If the heart rate reading is erratic or missing, do the following:

- Dry the hands to prevent slipping.
- Apply hands to the sensors that are set into the moving handlebars.
- Grasp the sensors firmly.
- Apply constant pressure around the sensors.

Recycle the Battery

Remove and recycle the rechargeable battery before discarding this product at the end of its useful life. Disconnect the power supply (*if applicable*) before removing the battery. To access the battery remove the screws that hold the upper rear cover to the back of the cross-trainer. The battery is located near the top of the frame, directly below the rear shrouds that are to be removed. To remove the battery, remove the two wires connected to the battery and the two screws that hold the battery in place. Dispose of the battery properly.

How to Obtain Product Service

1. Verify the symptom and review the operating instructions. The problem may be unfamiliarity with the product and its features and workouts.
2. Locate and write down the serial number of the unit which is located on the top right of the front stabilizer.
3. Contact Life Fitness Customer Support Services at <http://www.lifefitness.com>.

4. Assembly: INXSC, INXSX, INXDX, INXSSE, INXST, INXDSE, INXDST, CLUB SERIES +

Hardware and Required Tools

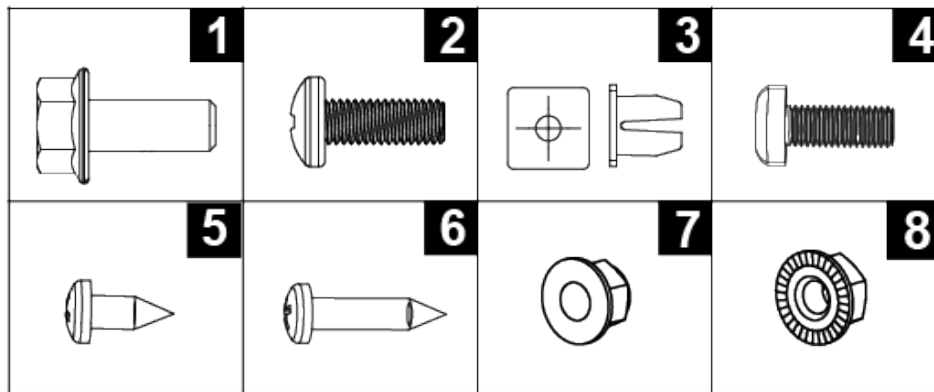

Item	Description	Qty.
1	M8 X 20 FLANGE HEX HEAD CAP SCREW	3
2	M6 X 16 PHILLIPS PAN HEAD SCREW	2
3	GROMMET	10
4	M5 X 14 PHILLIPS PAN HEAD SCREW	5
5	M4.2 X 10 PHILLIPS PAN HEAD SCREW	4
6	M4.2 X 19 PHILLIPS PAN HEAD SCREW	10
7	NUT: M8 X 1.25-6H, DIN, UNF, HEX, LOCKNUT (<i>for Moving Handles</i>)	8
8	NUT: M8 X 1.25-6H, HEX, LOCK, ZINC, CLASS 10 (<i>for Console Weldment</i>) NOTE: These nuts are serrated on the bottom side of the flange.	4

Required Tools:

- 13mm Socket
- Phillips Screw Driver, #2

Before You Begin

1. The console support weldment is positioned face down in the parts tray table packaging.

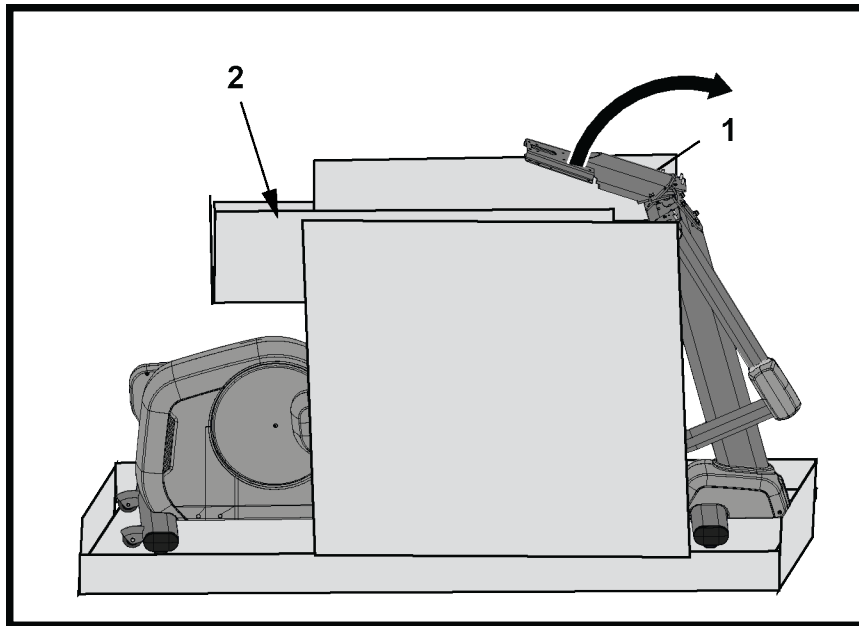



Item	Description	Qty.
1	Console Support Weldment	1
2	Parts Tray Table Packaging	1

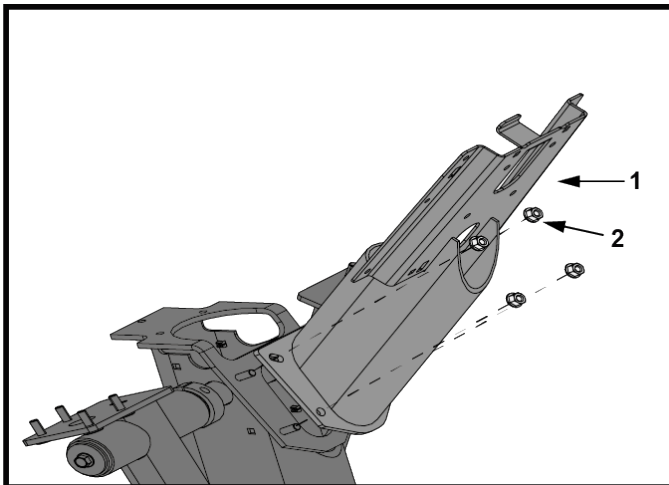

CAUTION: Remove any protective covering / tape from the monocolumn and console support weldment prior to attaching to base! Failure to remove the protective covering can cause improper grounding!

2. Lift the console support weldment up and out of the parts tray table.
3. Secure the console support weldment to the frame using four M8 Hex Locknuts (serrated on the bottom side of the flange).



Item	Description	Qty.
1	Console Support Weldment	1
2	M8 Hex Locknut	4
	27 Nm (19.91 ft. lbs.)	

Attach Bullhorn

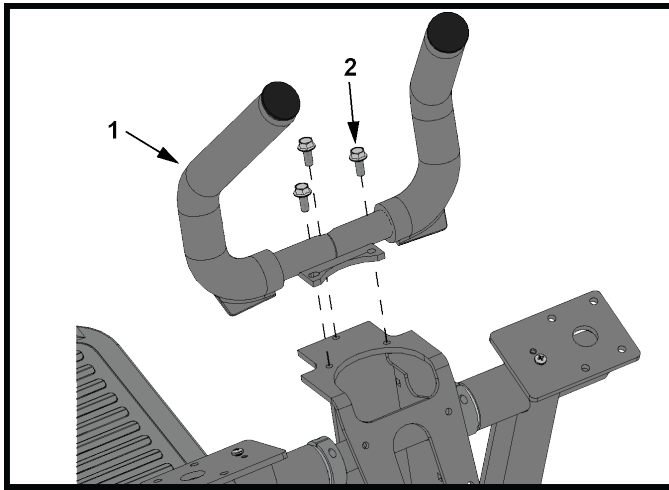

Item	Description	Qty.
1	Bullhorn	1
2	M8 X 20 Flange Head Cap Screw	3
	27 Nm (19.91 ft. lbs.)	

Attach Moving Handles

(Simple) INXSC, INXSX, INXSSE, INXST

Run Heart Rate Cable down through the opening and make connection.

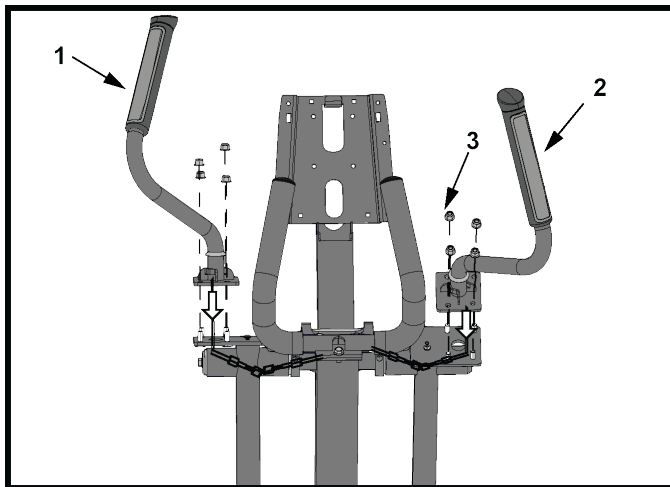

(Deluxe) INXDX, INXDSE, INXDST, CLUB SERIES +

Run Heart Rate Cable and Keypad Cable down through the opening and make connections.

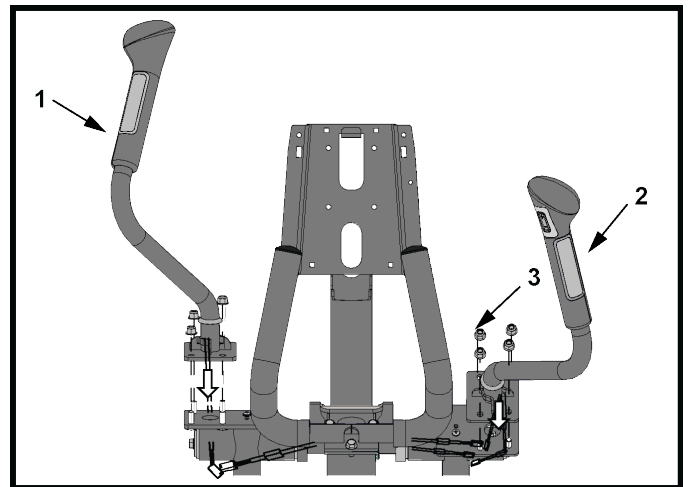

Item	Description	Qty.
1	Handlebar, Left	1
2	Handlebar, Right	1
3	M8 Locknut	8
	27 Nm (19.91 ft. lbs.)	

Attach Upper Right and Left Shrouds

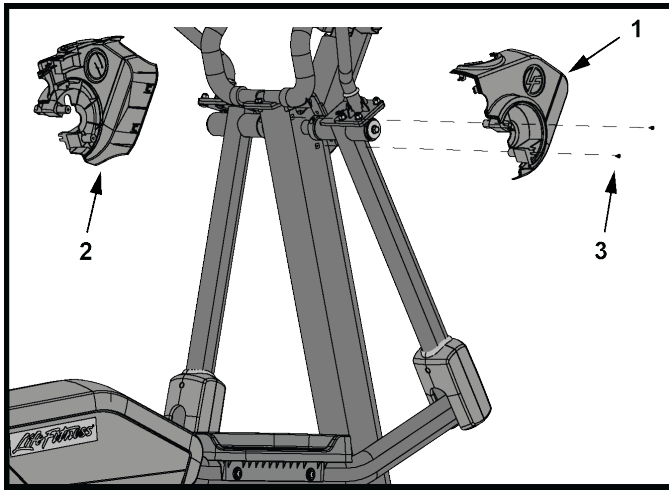

NOTE: Check for proper clip engagement after installing the upper shrouds.

Item	Description	Qty.
1	Shroud: Upper, Right	1
2	Shroud: Upper, Left	1
3	M4.2 X 10 Phillips Pan Head Screw	4
	1.5 Nm (13.3 in. lbs.)	

Attach Middle Shroud

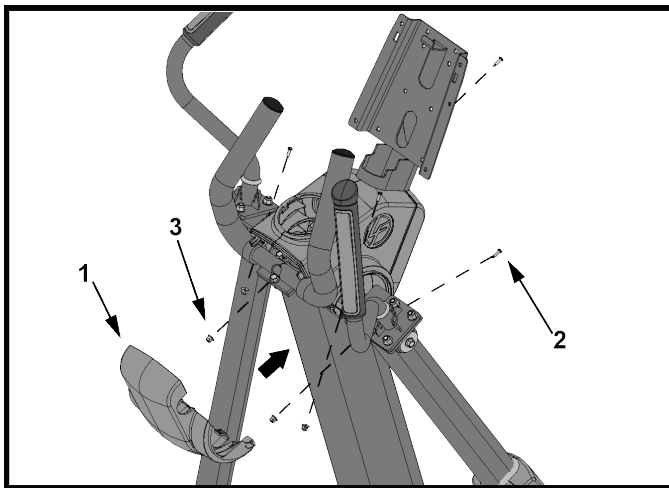

Item	Description	Qty.
1	Shroud: Middle	1
2	M4.2 X 19 Phillips Pan Head Screw	4
3	Grommet	4
	1.1 Nm (9.7 in. lbs.)	

Insert Cup Holder

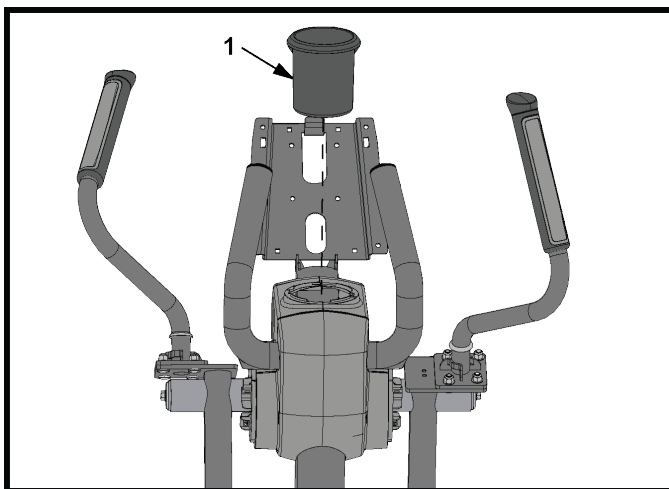



NOTE: Align cup ribs with shroud openings. Rotate cup counterclockwise to lock.

	Description	Qty.
1	Cup Holder	1

Attach Deadshaft Covers

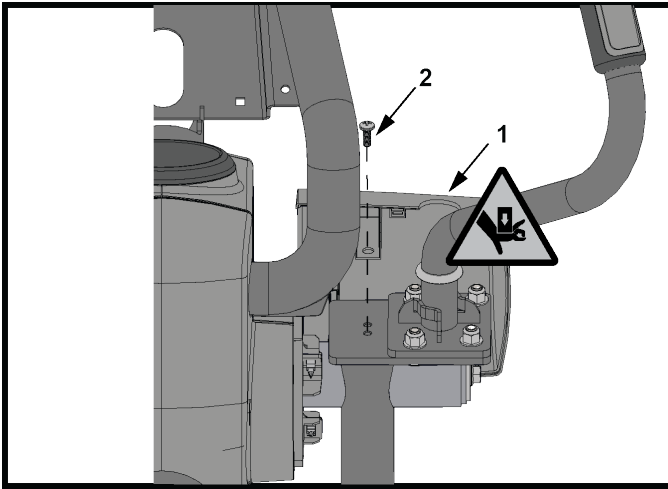
1. Secure rear deadshaft cover to rocker arm using one screw.



Item	Description	Qty
1	Deadshaft Cover, Rear	2
2	M6 X 16 Phillips Pan Head Screw	2
	1.5 Nm (13.3 in. lbs.)	

2. Add grommets to rear deadshaft cover. Interlock the front deadshaft cover into the rear deadshaft cover.

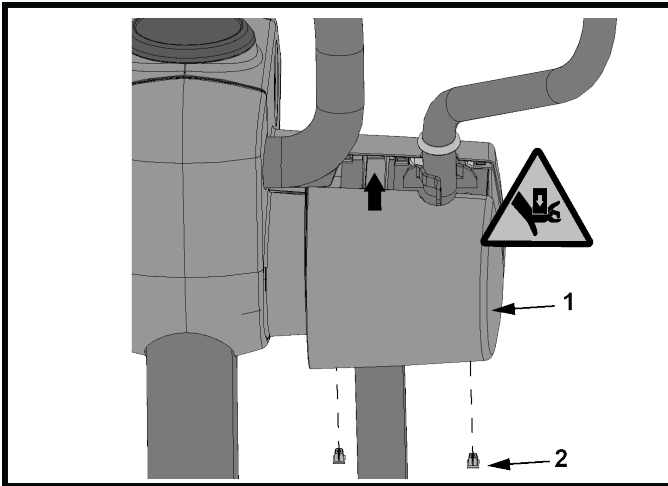

Item	Description	Qty
1	Deadshaft Cover, Front	2
2	Grommet	4

3. Secure the front deadshaft cover to the rear deadshaft cover using two screws and two grommets.
4. Position the gasket on top of the covers.

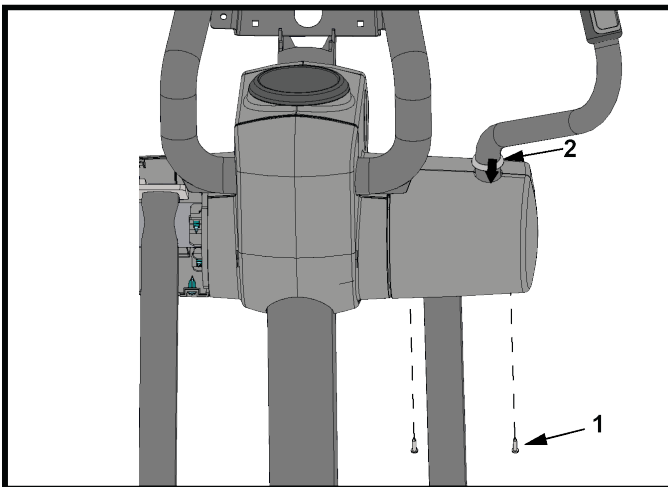

Item	Description	Qty
1	M4.2 X 19 Phillips Pan Head Screw	4
2	Gasket (<i>already attached</i>)	2
	1.1 Nm (9.7 in. lbs.)	

NOTE: Repeat the procedure reversing front and rear deadshaft covers for the remaining rocker arm. The front cover used on the first rocker arm becomes the rear cover on the remaining rocker arm.

Base to Console Cable Connections - Integrity X or Integrity C

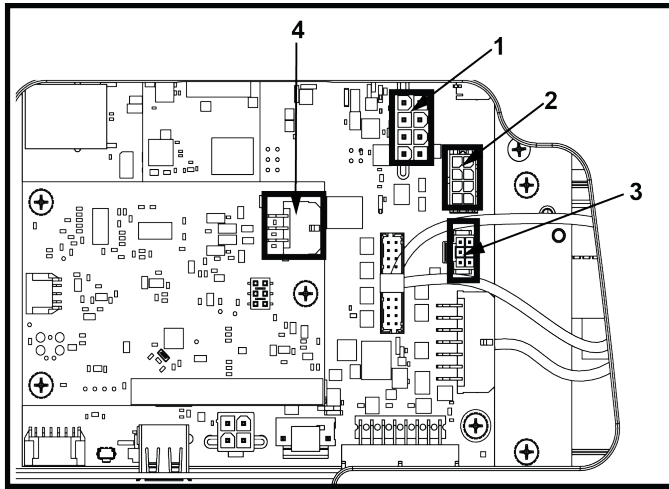

Item	Description
1	Console to Base Power
2	Base Signal
3	Handlebar Keypad Switches (Resistance)
4	Lifepulse

Base to Console Cable Connections - Discover SE3 / SE3 HD / ST

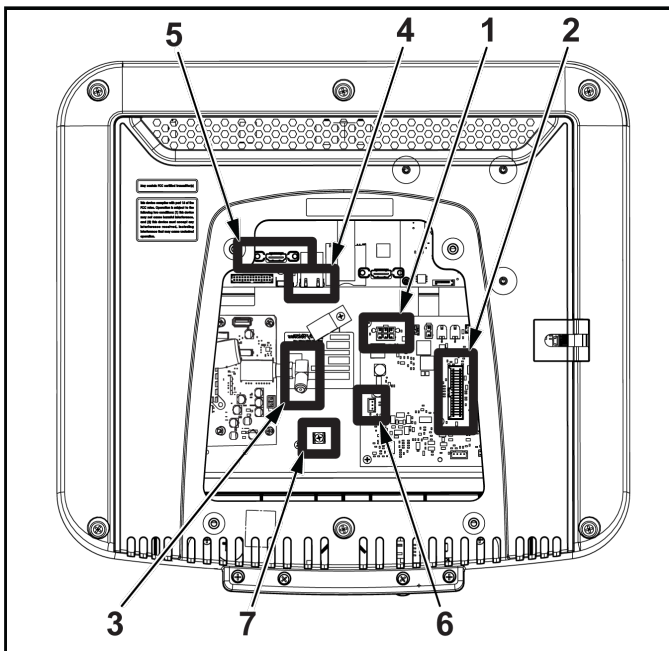

Item	Description
1	Power Cable, 24V
2	Base to Console Cable
3	Coaxial Cable
4	CAT5e
5	HDMI (<i>optional</i>)
6	IR (<i>optional</i>)
7	Ground Wire

Attach Console

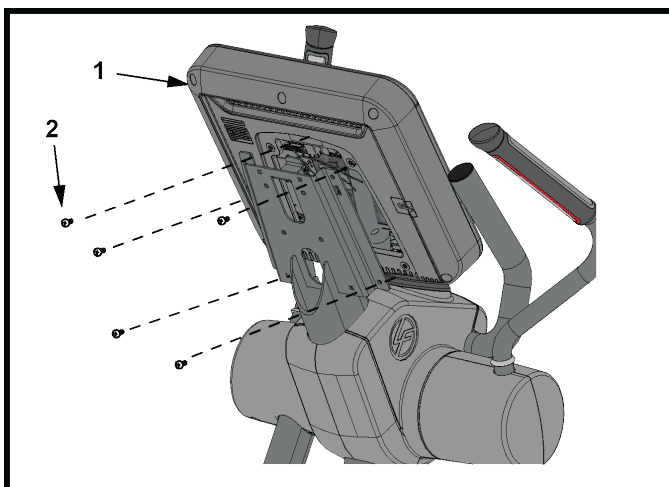

NOTE: Use the hook on top of the console support weldment to aid in console installation.

Item	Description	Qty.
1	Console	1
2	M5 X 14 Phillips Pan Head Screw	5
	1.9 Nm (1.4 ft. lbs.)	

5. Assembly: PF-INT-XT

Hardware and Required Tools

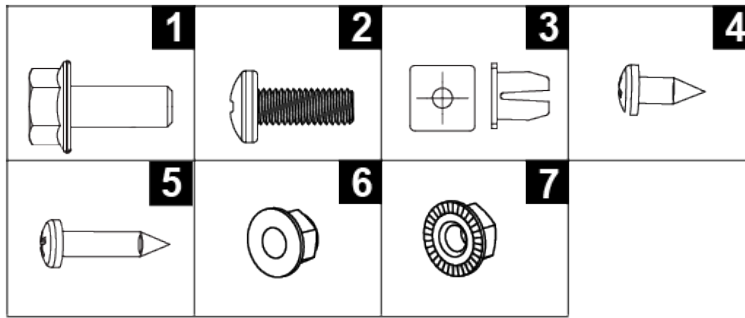

Item	Description	Qty.
1	M8 X 20 FLANGE HEX HEAD CAP SCREW	3
2	M6 X 16 PHILLIPS PAN HEAD SCREW	2
3	GROMMET	8
4	M4.2 X 10 PHILLIPS PAN HEAD SCREW	4
5	M4.2 X 19 PHILLIPS PAN HEAD SCREW	8
6	NUT: M8 X 1.25-6H, DIN, UNF, HEX, LOCKNUT (<i>for Moving Handles</i>)	8
7	NUT: M8 X 1.25-6H, HEX, LOCK, ZINC, CLASS 10 (<i>for Console Weldment</i>) NOTE: These nuts are serrated on the bottom side of the flange.	4

Required Tools:

- 13mm Socket
- Phillips Screw Driver, #2

Before You Begin

1. The console support weldment with console attached is positioned with the console face down in the parts tray table packaging.

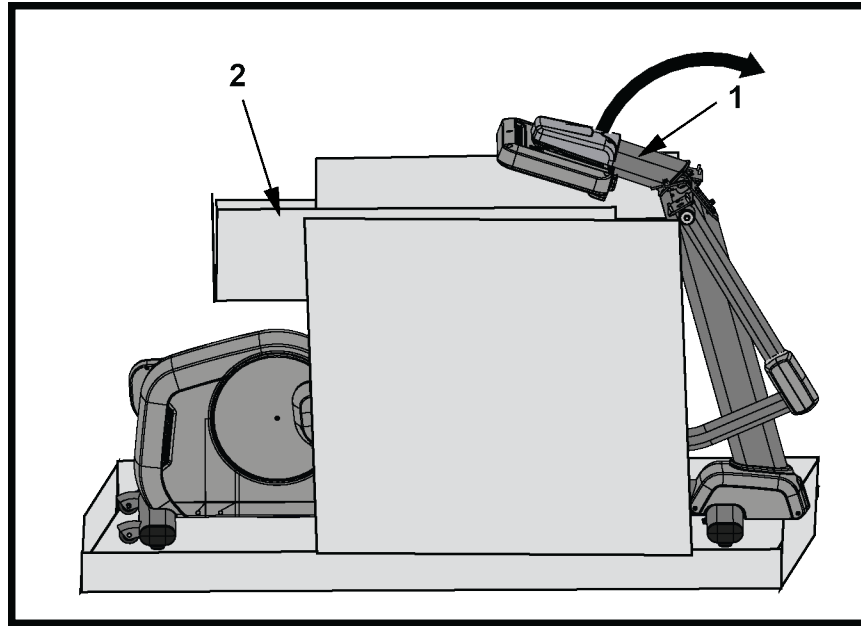



Item	Description	Qty.
1	Console Support Weldment	1
2	Parts Tray Table Packaging	1

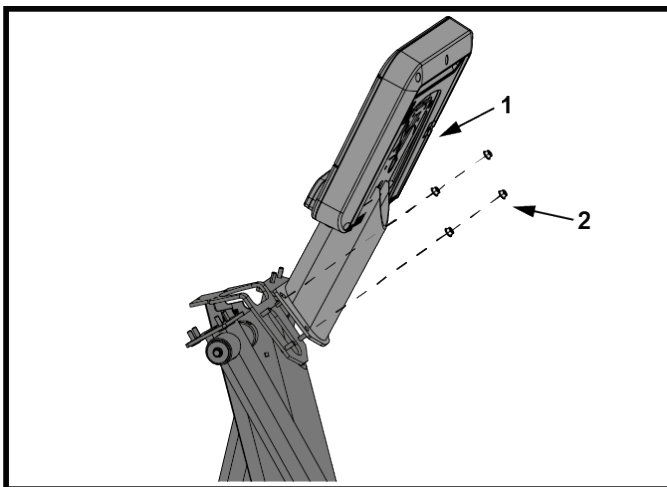

CAUTION: Remove any protective covering / tape from the monocolumn and console support weldment prior to attaching to base! Failure to remove the protective covering can cause improper grounding!

2. Lift the console support weldment up and out of the parts tray table.
3. Secure the console support weldment to the frame using four M8 Hex Locknuts (serrated on the bottom side of the flange).



Item	Description	Qty.
1	Console Support Weldment	1
2	M8 Hex Locknut	4
	27 Nm (19.91 ft. lbs.)	

Attach Bullhorn

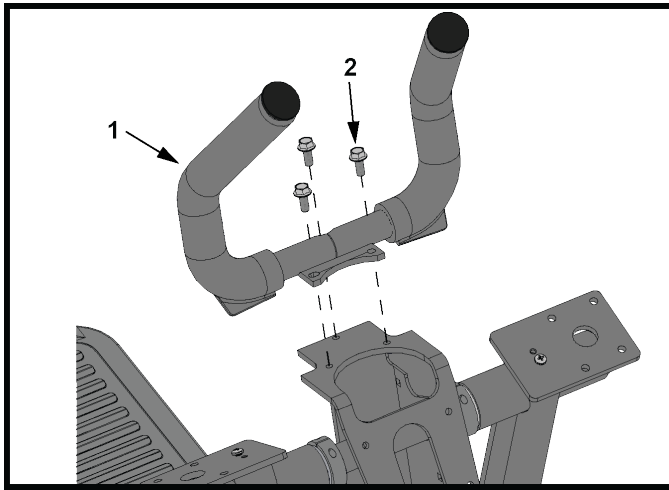

Item	Description	Qty.
1	Bullhorn	1
2	M8 X 20 Flange Head Cap Screw	3
	27 Nm (19.91 ft. lbs.)	

Attach Moving Handles

Run Heart Rate Cable down through the opening and make connection.

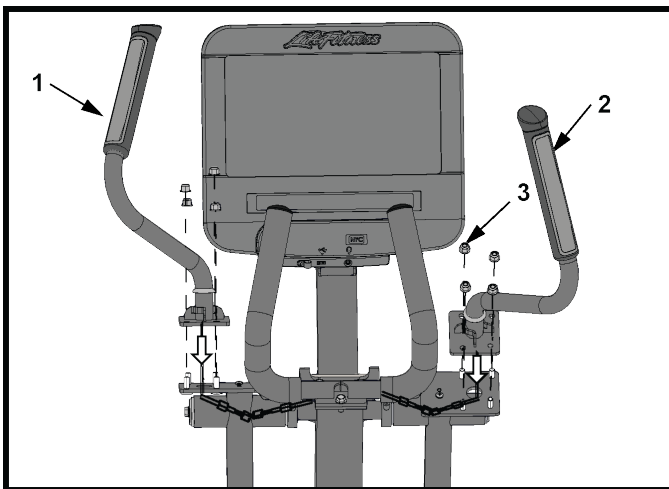

Item	Description	Qty
1	Handlebar, Left	1
2	Handlebar, Right	1
3	M8 Locknut	8
	27 Nm (19.91 ft. lbs.)	

Attach Upper Right and Left Shrouds

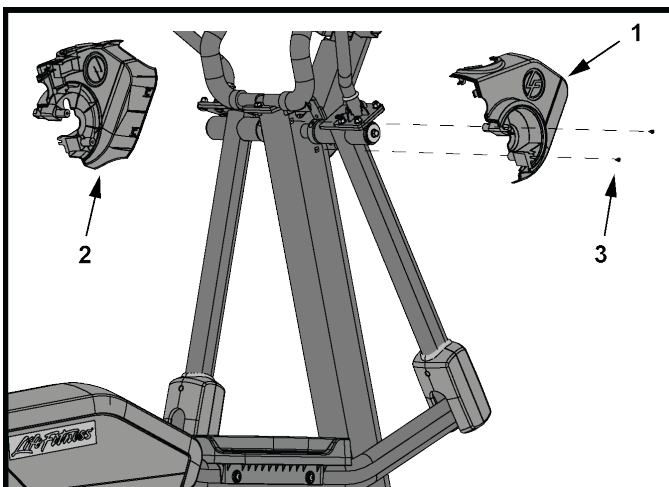

NOTE: Check for proper clip engagement after installing the upper shrouds.

Item	Description	Qty.
1	Shroud: Upper, Right	1
2	Shroud: Upper, Left	1
3	M4.2 X 10 Phillips Pan Head Screw	4
	1.5 Nm (13.3 in. lbs.)	

Attach Middle Shroud

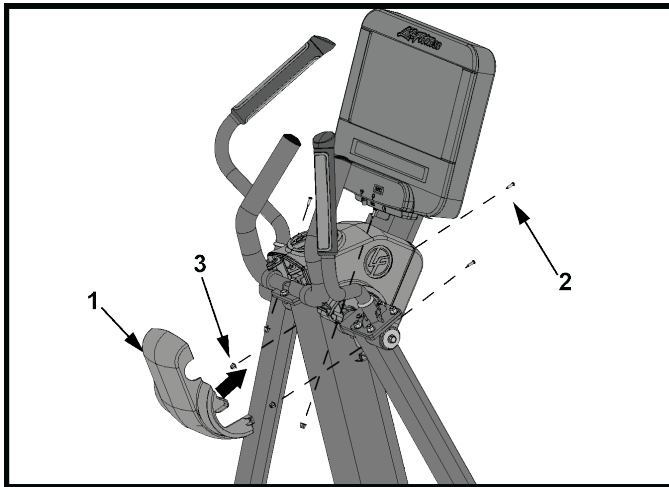

Item	Description	Qty.
1	Shroud: Middle	1
2	M4.2 X 19 Phillips Pan Head Screw	4
3	Grommet	4
	1.1 Nm (9.7 in. lbs.)	

Insert Cup Holder

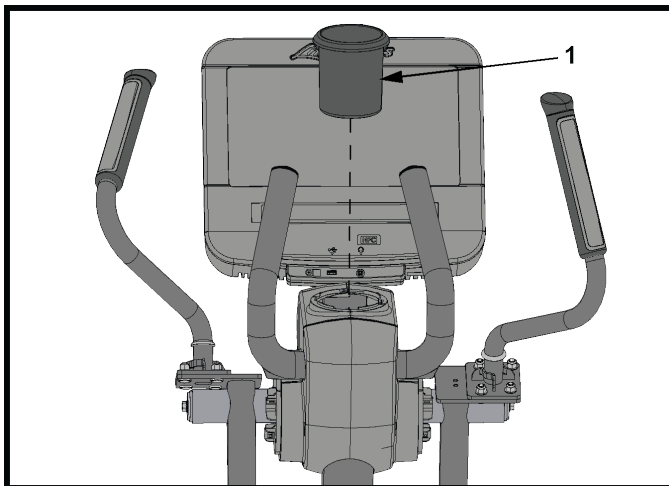



NOTE: Align cup ribs with shroud openings. Rotate cup counterclockwise to lock.

Item	Description	Qty.
1	Cup Holder	1

Attach Deadshaft Covers

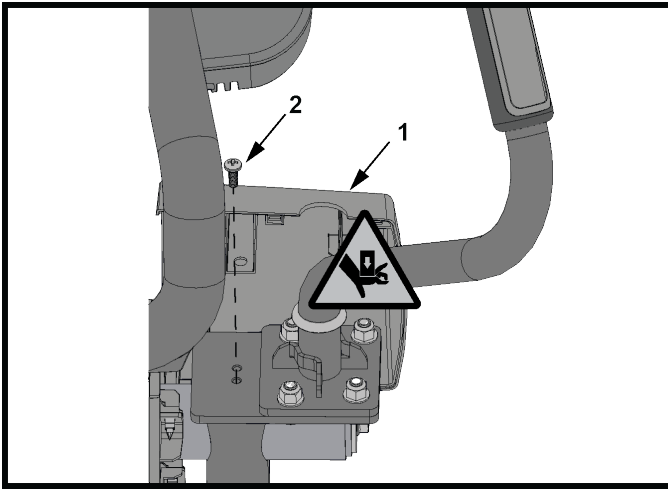
1. Secure rear deadshaft cover to rocker arm using one screw.



Item	Description	Qty
1	Deadshaft Cover, Rear	2
2	M6 X 16 Phillips Pan Head Screw	2
	1.5 Nm (13.3 in. lbs.)	

2. Add grommets to rear deadshaft cover. Interlock the front deadshaft cover into the rear deadshaft cover.

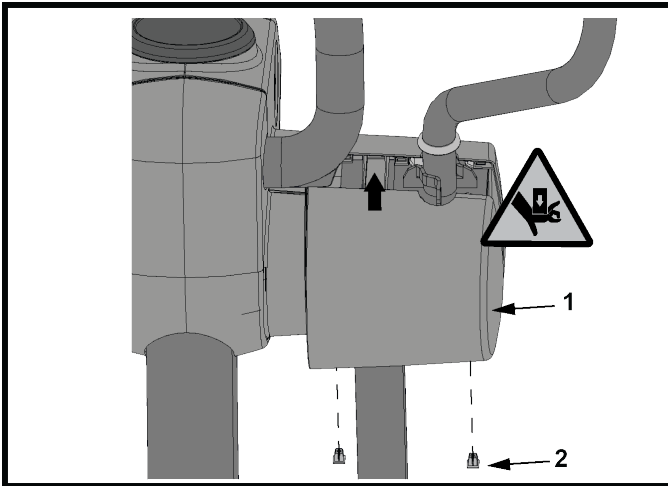

Item	Description	Qty
1	Deadshaft Cover, Front	2
2	Grommet	4

3. Secure the front deadshaft cover to the rear deadshaft cover using two screws and two grommets.
4. Position the gasket on top of the covers.

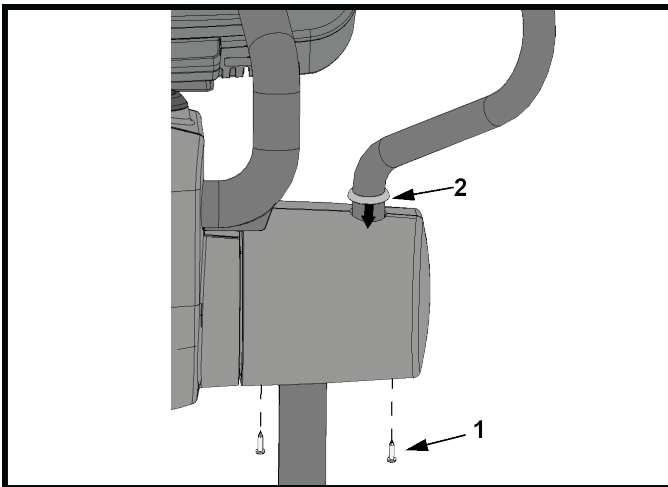

Item	Description	Qty
1	M4.2 X 19 Phillips Pan Head Screw	4
2	Gasket (<i>already attached</i>)	2
	1.1 Nm (9.7 in. lbs.)	

NOTE: Repeat the procedure reversing front and rear deadshaft covers for the remaining rocker arm. The front cover used on the first rocker arm becomes the rear cover on the remaining rocker arm.

6. Specifications

Specifications

Designed Use	Heavy / Commercial (INXSX, INXDX, INXSC, INXSSE, INXST, INXDSE, INXDST, PF-INT-XT) EN ISO 20957 Class SA
	Home (CLUB SERIES +) EN ISO 20957 Class HA
Maximum User Weight	400 lbs. / 181 kg
Drive Type	Generator
Pedal Speed Range	2.5 - 14 mph (4 - 22.5 kph)
Resistance Levels	26
Power Requirements	See <i>Electrical Power Requirements</i> Section
Heart Rate Monitoring Systems	Patented Lifepulse™ digital contact heart rate and Polar® telemetry compatible heart rate monitoring system

	Physical Dimensions of Cross-Trainer (without console)	Shipped Dimensions (INXSC, INXSX, INXDX, INXSSE, INXST, INXDSE, INXDST, CLUB SERIES +) (without console)	Shipped Dimensions (PF-INT-XT)
Length	87.2 in. / 221.5 cm	90 in. / 228.6 cm	89 in. / 226 cm
Width	29.7 in. / 75.4 cm (INXSX, INXSC, INXSSE, INXST, PF-INT-XT)	35 in. / 89 cm	36 in. / 91.4 cm
	28.9 in. / 73.4 cm (INXDX, INXDSE, INXDST, Club Series +)		
Height	62.6 in. / 159 cm (INXSX, INXSC, INXSSE, INXST, PF-INT-XT)	51 in. / 129.5 cm	52 in. / 132 cm
	63.9 in. / 162 cm (INXDX, INXDSE, INXDST, Club Series +)		
Weight	298 lbs. / 135 kg (INXSX, INXSC, INXSSE, INXST, PF-INT-XT)	309 lbs. / 140 kg	321 lbs. / 145.6 kg
	301 lbs. / 136.5 kg (INXDX, INXDSE, INXDST, Club Series +)		

